

## Chapter 5

# Aircraft Welding

### Introduction

Welding can be traced back to the Bronze Age, but it was not until the 19<sup>th</sup> century that welding as we know it today was invented. Some of the first successful commercially manufactured aircraft were constructed from welded steel tube frames.

As the technology and manufacturing processes evolved in the aircraft and aerospace industry, lighter metals, such as aluminum, magnesium, and titanium, were used in their construction. New processes and methods of welding these metals were developed. This chapter provides some of the basic information needed to understand and initiate the various welding methods and processes.

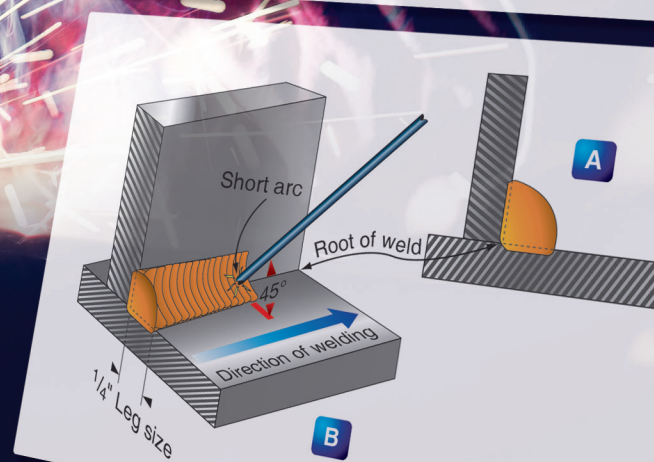
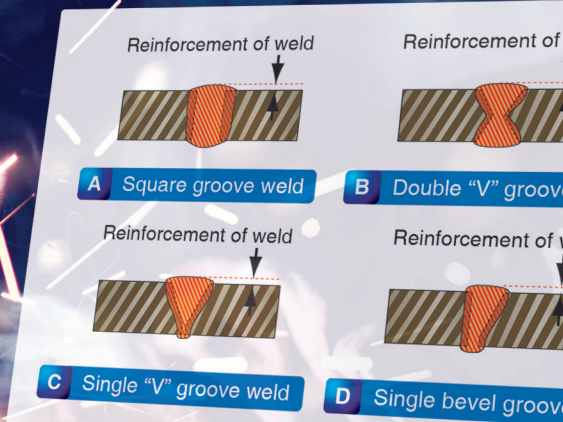
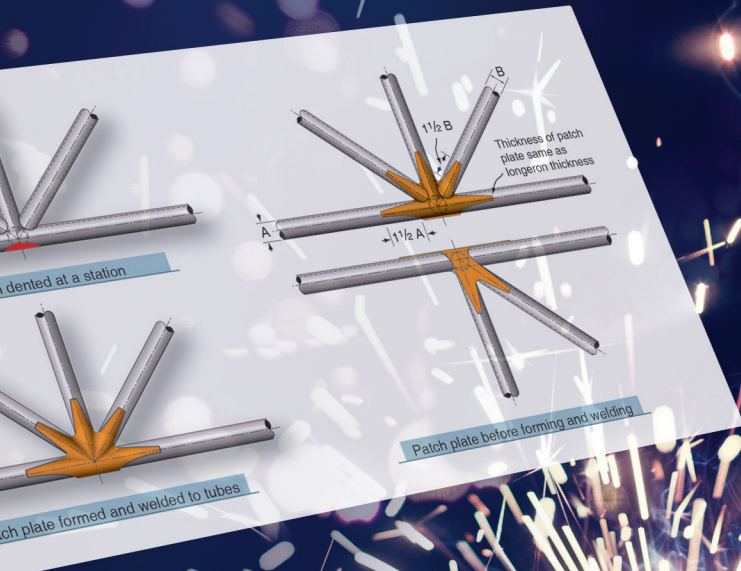

Traditionally, welding is defined as a process that joins metal by melting or hammering the work pieces until they are united together. With the right equipment and instruction, almost anyone with some basic mechanical skill, dexterity, and practice can learn to weld.

There are three general types of welding: gas, electric arc, and electric resistance. Each type of welding has several variations, some of which are used in the construction of aircraft. Additionally, there are some new welding processes that have been developed in recent years that are highlighted for the purpose of information.

This chapter addresses the welding equipment, methods, and various techniques used during the repair of aircraft and fabrication of component parts, including the processes of brazing and soldering of various metals.

## Types of Welding

### Gas Welding

Gas welding is accomplished by heating the ends or edges of metal parts to a molten state with a high temperature flame. The oxy-acetylene flame, with a temperature of approximately 6,300 °Fahrenheit (F), is produced with a torch burning acetylene and mixing it with pure oxygen. Hydrogen may be used in place of acetylene for aluminum welding, but the heat output is reduced to about 4,800 °F. Gas welding was the method most commonly used in production on aircraft materials under  $\frac{3}{16}$ -inch in thickness until the mid 1950s, when it was replaced by electric welding for economic (not engineering) reasons. Gas welding continues to be a very popular and proven method for repair operations.

Nearly all gas welding in aircraft fabrication is performed with oxy-acetylene welding equipment consisting of:

- Two cylinders, acetylene and oxygen.
- Acetylene and oxygen pressure regulators and cylinder pressure gauges.
- Two lengths of colored hose (red for acetylene and green for oxygen) with adapter connections for the regulators and torch.
- A welding torch with an internal mixing head, various size tips, and hose connections.
- Welding goggles fitted with appropriate colored lenses.
- A flint or spark lighter.
- Special wrench for acetylene tank valve if needed.
- An appropriately-rated fire extinguisher.

The equipment may be permanently installed in a shop, but most welding outfits are of the portable type. [Figure 5-1]

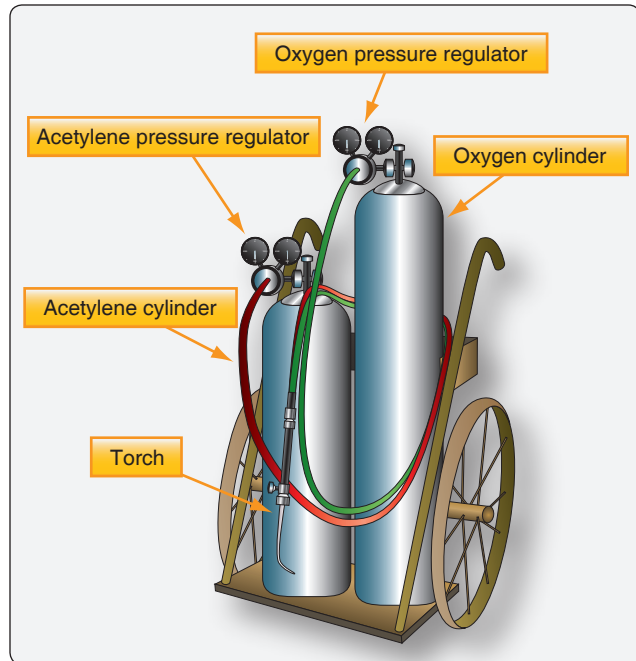

Figure 5-1. Portable oxy-acetylene welding outfit.

### Electric Arc Welding

Electric arc welding is used extensively by the aircraft industry in both the manufacture and repair of aircraft. It can be used satisfactorily to join all weldable metals, provided that the proper processes and materials are used. The four types of electric arc welding are addressed in the following paragraphs.

#### Shielded Metal Arc Welding (SMAW)

Shielded metal arc welding (SMAW) is the most common type of welding and is usually referred to as “stick” welding. The equipment consists of a metal wire rod coated with a welding flux that is clamped in an electrode holder that is connected by a heavy electrical cable to a low voltage and high current in either alternating current (AC) or direct current (DC), depending on the type of welding being done. An arc is struck between the rod and the work and produces heat in excess of 10,000 °F, which melts both the material and the rod. The welding circuit consists of a welding machine, two leads, an electrode holder, an electrode, and the work to be welded. [Figure 5-2]

When the electrode is touched to the metal to be welded, the circuit is complete and the current flows. The electrode is then withdrawn from the metal approximately  $\frac{1}{4}$ -inch to form an air gap between the metal and the electrode. If the correct gap is maintained, the current bridges the gap to form a sustained electric spark called the arc. This action melts the electrode and the coating of flux.

As the flux melts, it releases an inert gas that shields the molten puddle from oxygen in the air to prevent oxidation.

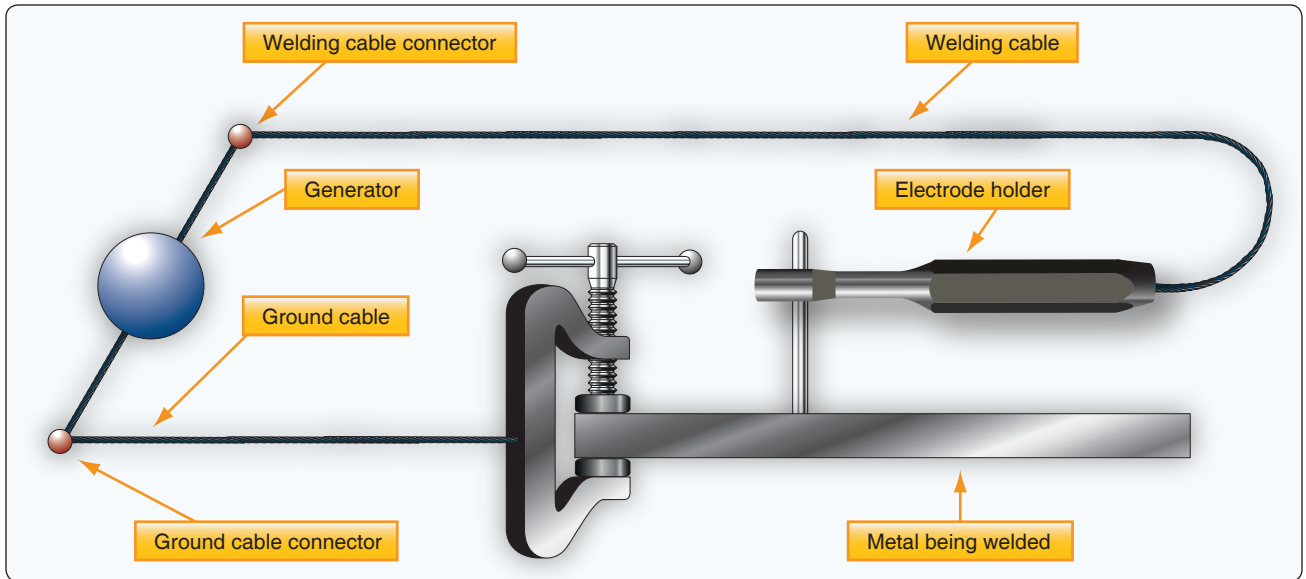

**Figure 5-2.** Typical arc welding circuit.

The molten flux covers the weld and hardens to an airtight slag that protects the weld bead as it cools. Some aircraft manufacturers, such as Stinson, used this process for the welding of 4130 steel fuselage structures. This was followed by heat treatment in an oven to stress relieve and normalize the structure. Shown in *Figure 5-3* is a typical arc welding machine with cables, ground clamp, and electrode holder.

### Gas Metal Arc Welding (GMAW)

Gas metal arc welding (GMAW) was formerly called gas inert gas (MIG) welding. It is an improvement over stick welding because an uncoated wire electrode is fed into and through the torch and an inert gas, such as argon, helium, or carbon dioxide, flows out around the wire to protect the puddle from oxygen. The power supply is connected to the torch and the work, and the arc produces the intense heat needed to melt the work and the electrode. [*Figure 5-4*]



**Figure 5-3.** Stick welder—Shielded Metal Arc Welder (SMAW).

Low-voltage, high-current DC is typically used with GMAW welding. *Figure 5-5* shows the equipment required for a typical MIG welding setup.

This method of welding can be used for large volume manufacturing and production work; it is not well suited to repair work because weld quality cannot be easily determined without destructive testing. *Figure 5-6* depicts a typical power source used for MIG welding.

### Gas Tungsten Arc Welding (GTAW)

Gas tungsten arc welding (GTAW) is a method of electric arc welding that fills most of the needs in aircraft maintenance and repair when proper procedures and materials are used. It is the preferred method to use on stainless steel, magnesium, and most forms of thick aluminum. It is more commonly known as Tungsten Inert Gas (TIG) welding and by the trade names of Heliarc or Heliweld. These names were derived from the inert helium gas that was originally used.

The first two methods of electric arc welding that were addressed used a consumable electrode that produced the filler for the weld. In TIG welding, the electrode is a tungsten rod that forms the path for the high amperage arc between it and the work to melt the metal at over 5,400 °F. The electrode is not consumed and used as filler so a filler rod is manually fed into the molten puddle in almost the same manner as when using an oxy-acetylene torch. A stream of inert gas, such as argon or helium, flows out around the electrode and envelopes the arc thereby preventing the formation of oxides in the molten puddle. [*Figure 5-7*]

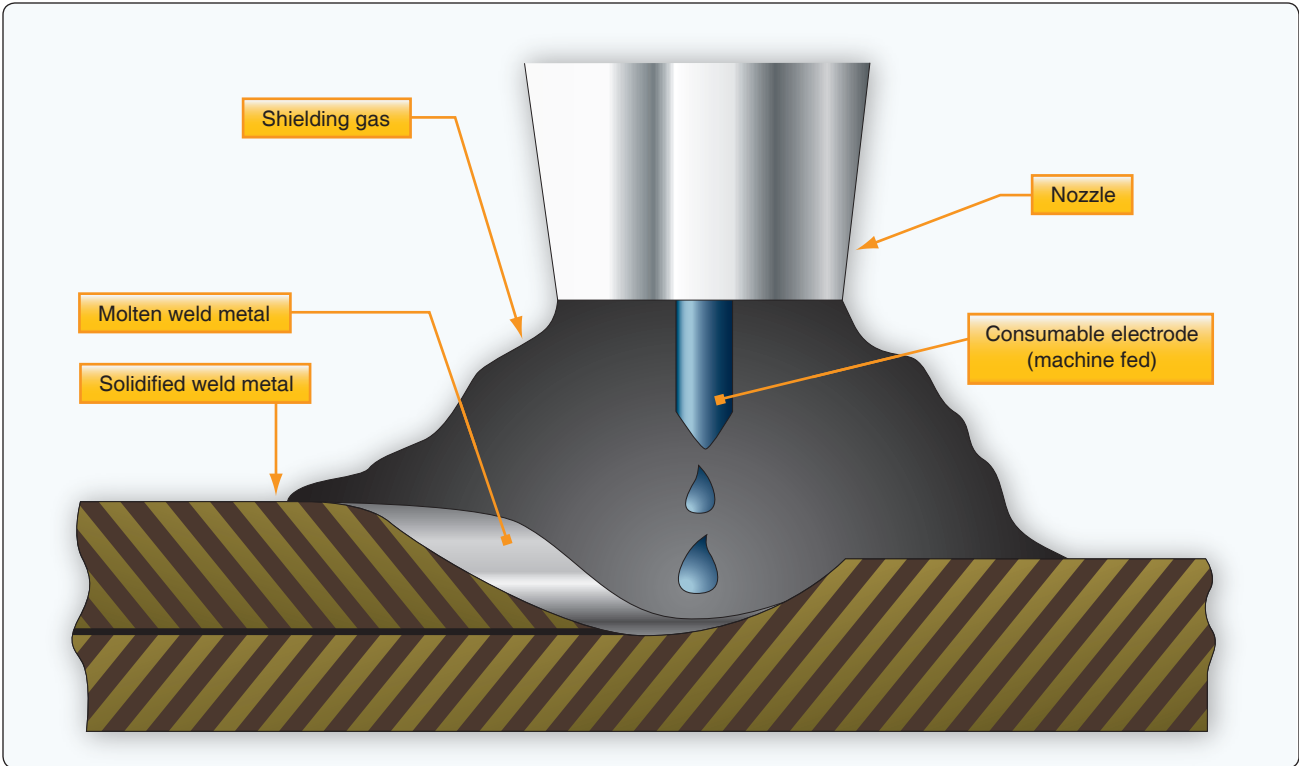

Figure 5-4. Metal inert gas (MIG) welding process.

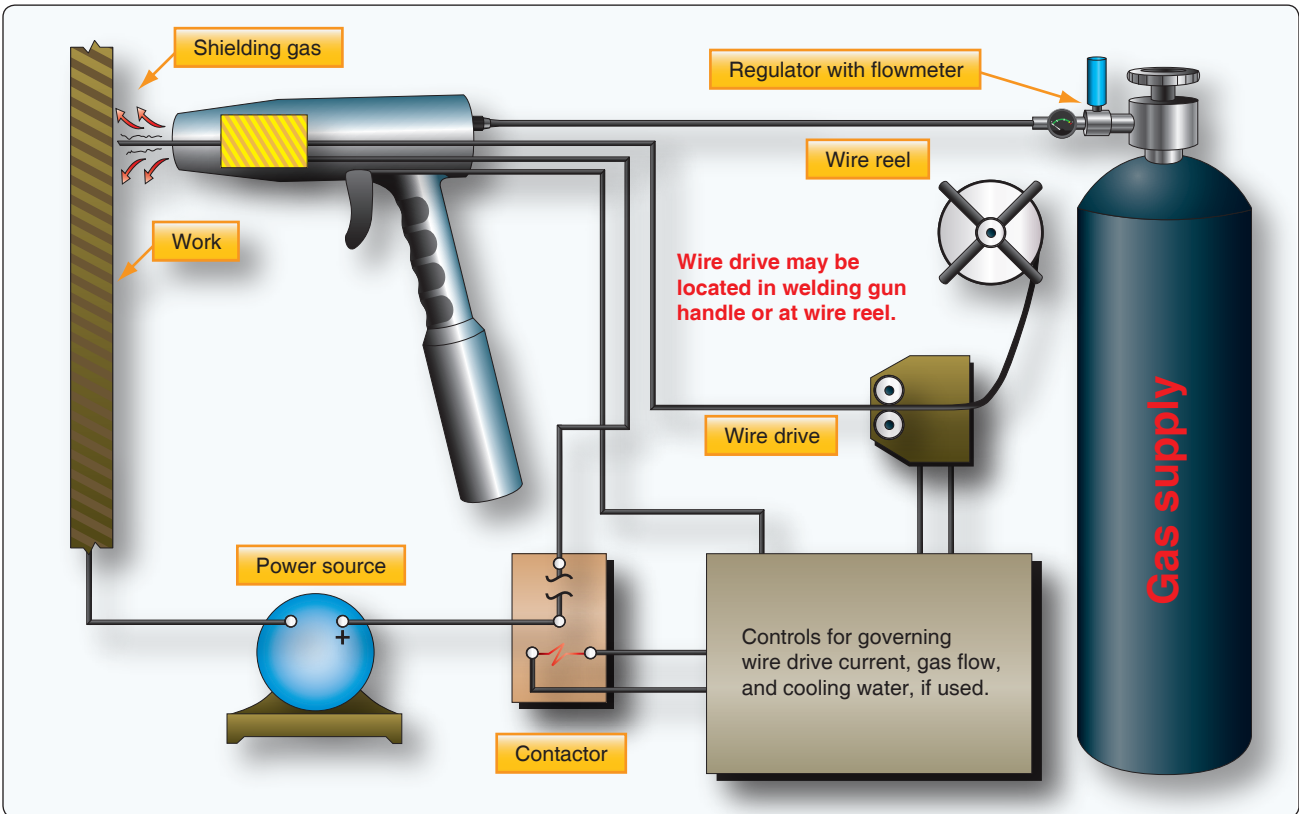

Figure 5-5. MIG welding equipment.



Figure 5-6. MIG welder—gas metal arc welder (GMAW).

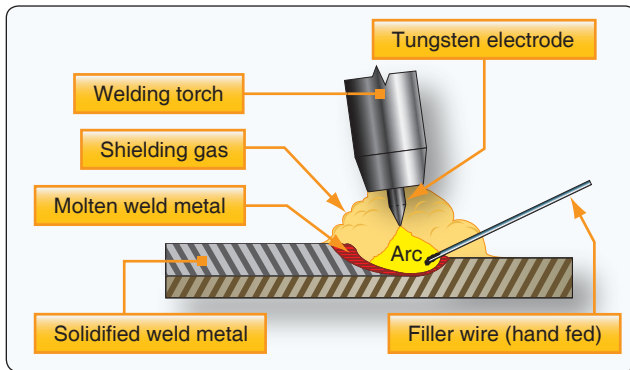

Figure 5-7. Tungsten inert gas (TIG) welding process.

The versatility of a TIG welder is increased by the choice of the power supply being used. DC of either polarity or AC may be used. [Figure 5-8]

- Either select the welder setting to DC straight polarity (the work being the positive and the torch being negative) when welding mild steel, stainless steel, and titanium; or
- Select AC for welding aluminum and magnesium.

Figure 5-9 is a typical power source for TIG welding along with a torch, foot operated current control, regulator for inert gas, and assorted power cables.



Figure 5-9. TIG welder—gas tungsten arc welder (GTAW).

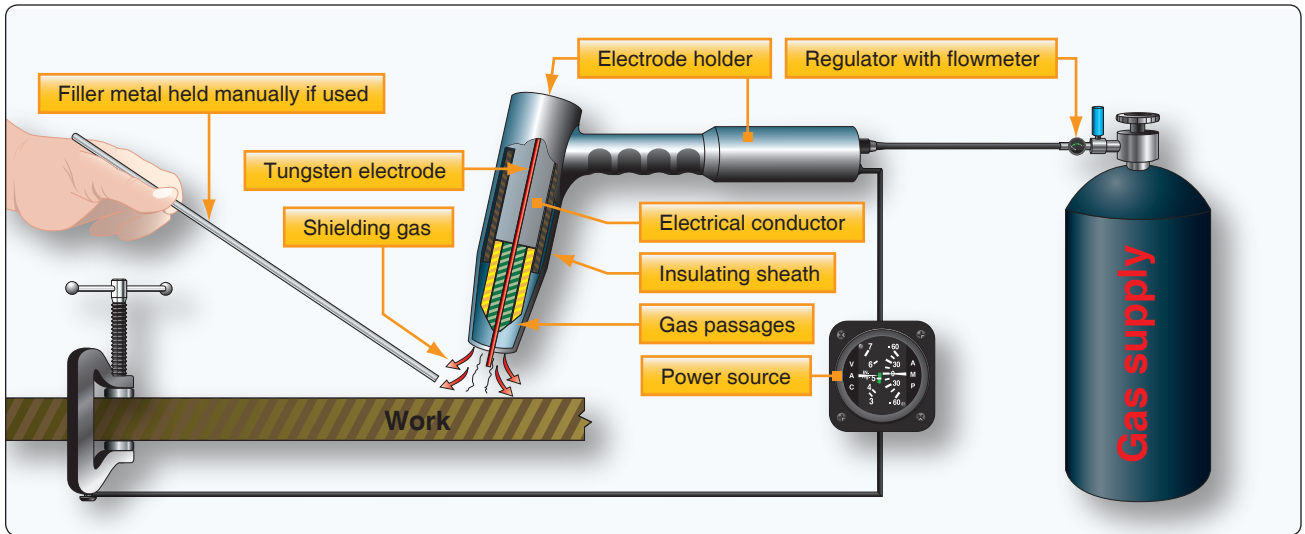

Figure 5-8. Typical setup for TIG welding.

## Electric Resistance Welding

Electric resistance welding, either spot welding or seam welding, is typically used to join thin sheet metal components during the manufacturing process.

### Spot Welding

Two copper electrodes are held in the jaws of the spot welding machine, and the material to be welded is clamped between them. Pressure is applied to hold the electrodes tightly together and electrical current flows through the electrodes and the material. The resistance of the material being welded is so much higher than that of the copper electrodes that enough heat is generated to melt the metal. The pressure on the electrodes forces the molten spots in the two pieces of metal to unite, and this pressure is held after the current stops flowing long enough for the metal to solidify. The amount of current, pressure, and dwell time are all carefully controlled and matched to the type of material and the thickness to produce the correct spot welds. [Figure 5-10]

### Seam Welding

Rather than having to release the electrodes and move the material to form a series of spot welds, a seam-welding machine is used to manufacture fuel tanks and other components where a continuous weld is needed. Two copper wheels replace the bar-shaped electrodes. The metal to be welded is moved between them, and electric pulses create spots of molten metal that overlap to form the continuous seam.

## Plasma Arc Welding (PAW)

Plasma arc welding (PAW) was developed in 1964 as a method of bringing better control to the arc welding process. PAW provides an advanced level of control and accuracy

using automated equipment to produce high quality welds in miniature and precision applications. Furthermore, PAW is equally suited to manual operation and can be performed by a person using skills similar to those for GTAW.

In the plasma welding torch, a nonconsumable tungsten electrode is located within a fine-bore copper nozzle. A pilot arc is initiated between the torch electrode and nozzle tip. This arc is then transferred to the metal being welded. [Figure 5-11]

By forcing the plasma gas and arc through a constricted orifice, the torch delivers a high concentration of heat to a small area. The plasma process produces exceptionally high quality welds. [Figure 5-12]

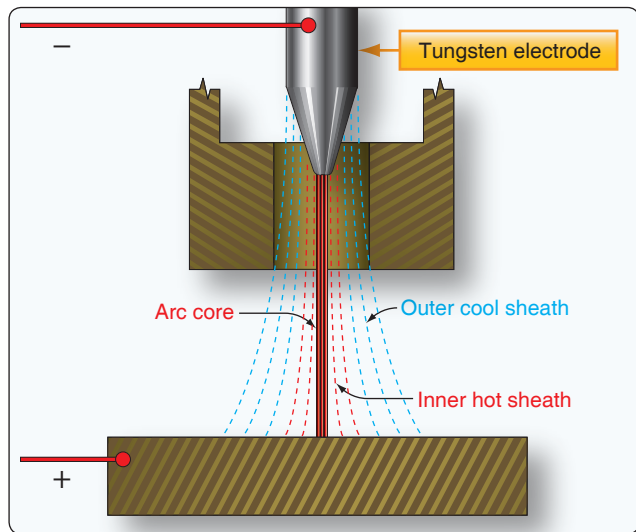

Figure 5-11. The plasma welding process.



Figure 5-10. Spot welding thin sheet metal.

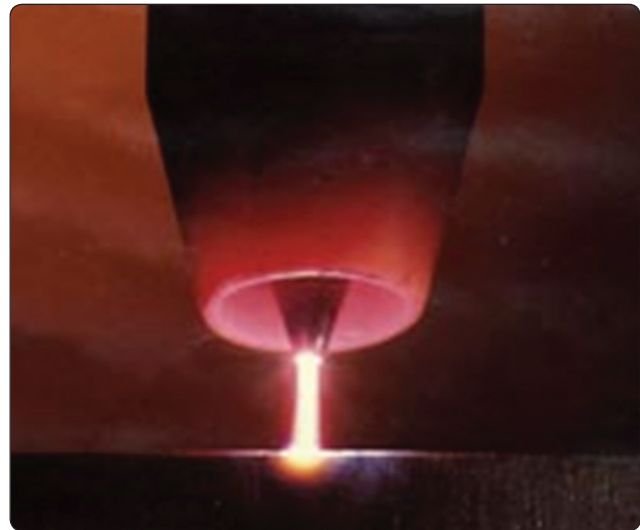

Figure 5-12. Plasma arc.

Plasma gas is normally argon. The torch also uses a secondary gas, such as argon/helium or argon/nitrogen, that assists in shielding the molten weld puddle and minimizing oxidation of the weld.

Like GTAW, the PAW process can be used to weld most commercial metals, and it can be used for a wide variety of metal thicknesses. On thin material, from foil to 1/8-inch, the process is desirable because of the low heat input. The process provides relatively constant heat input because arc length variations are not very critical. On material thicknesses greater than 1/8-inch and using automated equipment, a keyhole technique is often used to produce full penetration single-path welds. In the keyhole technique, the plasma completely penetrates the work piece. The molten weld metal flows to the rear of the keyhole and solidifies as the torch moves on. The high quality welds produced are characterized by deep, narrow penetration and a small weld face.

When PAW is performed manually, the process requires a high degree of welding skills similar to that required for GTAW. However, the equipment is more complex and requires a high degree of knowledge to set up and use. The equipment required for PAW includes a welding machine, a special plasma arc control system, the plasma welding torch (water-cooled), the source of plasma and shielding gas, and filler material, when required. Because of the cost associated with this equipment, this process is very limited outside of manufacturing facilities.

### **Plasma Arc Cutting**

When a plasma cutting torch is used, the gas is usually compressed air. The plasma cutting machine works by constricting an electrical arc in a nozzle and forcing the ionized gas through it. This heats the gas that melts the metal which is blown away by the air pressure. By increasing air pressure and intensifying the arc with higher voltages, the cutter is capable of blasting through thicker metals and blowing away the dross with minimal cleanup.

Plasma arc systems can cut all electrically conductive metals, including aluminum and stainless steel. These two metals cannot be cut by oxy-fuel cutting systems because they have an oxide layer that prevents oxidation from occurring. Plasma cutting works well on thin metals and can successfully cut brass and copper in excess of two inches thick.

Plasma cutting machines can rapidly and precisely cut through, gouge, or pierce any electrically conductive metal without preheating. The plasma cutter produces a precise kerf (cut) width and a small heat-affected zone (HAZ) that prevents warping and damage.

## **Gas Welding and Cutting Equipment**

### **Welding Gases**

#### ***Acetylene***

This is the primary fuel for oxy-fuel welding and cutting. It is chemically very unstable, and is stored in special cylinders designed to keep the gas dissolved. The cylinders are packed with a porous material and then saturated with acetone. When the acetylene is added to the cylinder, it dissolves; in this solution, it becomes stable. Pure acetylene stored in a free state explodes from a slight shock at 29.4 pounds per square inch (psi). The acetylene pressure gauge should never be set higher than 15 psi for welding or cutting.

#### ***Argon***

Argon is a colorless, odorless, tasteless, and non-toxic inert gas. Inert gas cannot combine with other elements. It has a very low chemical reactivity and low thermal conductivity. It is used as a gas shield for the electrode in MIG, TIG, and plasma welding equipment.

#### ***Helium***

Helium is a colorless, odorless, tasteless, and non-toxic inert gas. Its boiling and melting points are the lowest of the elements and it normally exists only in gas form. It is used as a protective gas shield for many industrial uses including electric arc welding.

#### ***Hydrogen***

Hydrogen is a colorless, odorless, tasteless, and highly flammable gas. It can be used at a higher pressure than acetylene and is used for underwater welding and cutting. It also can be used for aluminum welding using the oxy-hydrogen process.

#### ***Oxygen***

Oxygen is a colorless, odorless, and nonflammable gas. It is used in the welding process to increase the combustion rate which increases the flame temperature of flammable gas.

### **Pressure Regulators**

A pressure regulator is attached to a gas cylinder and is used to lower the cylinder pressure to the desired working pressure. Regulators have two gauges, one indicating the pressure in the cylinder and the second showing the working pressure. By turning the adjustment knob in or out, a spring operating a flexible diaphragm opens or closes a valve in the regulator. Turning the knob in causes the flow and pressure to increase; backing it out decreases the flow and pressure.

There are two types of regulators: single stage and two stage. They perform the same function but the two-stage regulator maintains a more constant outlet pressure and flow as the cylinder volume and pressure drops. Two-stage regulators can be identified by a larger, second pressure chamber under the regulator knob. [Figures 5-13 and 5-14]

### Welding Hose

A welding hose connects the regulators to the torch. It is typically a double hose joined together during manufacture. The acetylene hose is red and has left hand threads indicated by a groove cut into the connection nut. The oxygen hose is green and has right hand threads indicated by the absence of a groove on the connection nut.



**Figure 5-13.** Single-stage acetylene regulator. Note the maximum 15-psi working pressure. The notched groove cylinder connection nut indicates a left-hand thread.



**Figure 5-14.** Two-stage oxygen regulator. No groove on the cylinder connection nut indicates a right-hand thread.

Welding hoses are produced in different sizes from ¼-inch to ½-inch inside diameter (ID). The hose should be marked for light, standard, and heavy duty service plus a grade indicating whether it has an oil- and/or flame-resistant cover. The hose should have the date of manufacture, maximum working pressure of 200 psi, and indicate that it meets specification IP-90 of the Rubber Manufacturers Association and the Compressed Gas Association for rubber welding hoses. Grade-R hose should only be used with acetylene gas. A T-grade hose must be used with propane, MAPP®, and all other fuel gases.

### Check Valves and Flashback Arrestors

The check valve stops the reverse flow of the gas and can be installed either between the regulator and the hose or the hose and the torch. [Figure 5-15] Excessive overheating of cutting, welding, and heating tips can cause flashback conditions. A flashback can be caused when a tip is overheated and the gas ignites before passing out of the tip. The flame is then burning internally rather than on the outside of the tip and is usually identified by a shrill hissing or squealing noise.

A flashback arrestor installed on each hose prevents a high pressure flame or oxygen-fuel mixture from being pushed back into either cylinder causing an explosion. The flashback arrestors incorporate a check valve that stops the reverse flow of gas and the advancement of a flashback fire. [Figure 5-16]

### Torches

#### Equal Pressure Torch

The equal pressure torch is the most commonly used torch for oxy-acetylene welding. It has a mixing chamber and uses acetylene fuel at 1–15 psi. The flame is easy to adjust and there is less chance of flashback with this torch. There are

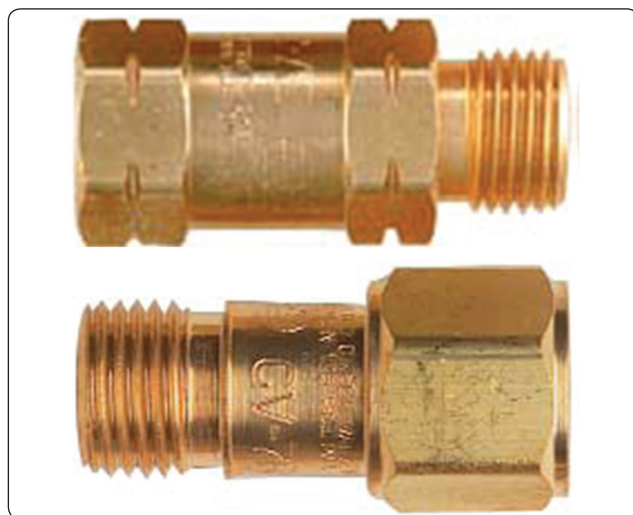

**Figure 5-15.** Check valves.





Figure 5-16. Flashback arrestors.

several small lightweight torches of this type that are ideal for aviation welding projects. The Smith Airline™ and the Meco Midget™ torches are small enough to be used in close confined areas, lightweight enough to reduce fatigue during long welding sessions yet, with the appropriate tips, are capable of welding 0.250-inch steel.

### Injector Torch

The injector torch uses fuel gas at pressures between just above 0 and 2 psi. This torch is typically used with propane and propylene gas. High-pressure oxygen comes through a small nozzle inside the torch head and pulls the fuel gas along with it via a venturi effect. The low-pressure injector torch is more prone to flashback.

### Cutting Torch

The cutting torch is an attachment added to the torch handle that allows the cutting of metal. The cutting process is fundamentally the rapid burning or oxidizing of the metal in a localized area. The metal is heated to a bright red color (1,400 °F to 1,600 °F), which is the kindling temperature, using only the preheat jets. Then, a jet of high-pressure oxygen released by the lever on the cutting attachment is directed against the heated metal. This oxygen blast combines with the hot metal and forms an intensely hot oxide. The molten oxide is blown down the sides of the cut, heating the metal in its path to the kindling temperature as the torch is moved along the line of the desired cut. The heated metal also burns to an oxide that is blown away on the underside of the piece. [Figure 5-17]

### Torch Tips

The torch tip delivers and controls the final flow of gases. It is important that you use the correct tip with the proper gas pressures for the work to be welded satisfactorily. The size of the tip opening—not the temperature—determines the amount of heat applied to the work. If an excessively small tip is used, the heat provided is insufficient to produce penetration to the proper depth. If the tip is too large, the heat

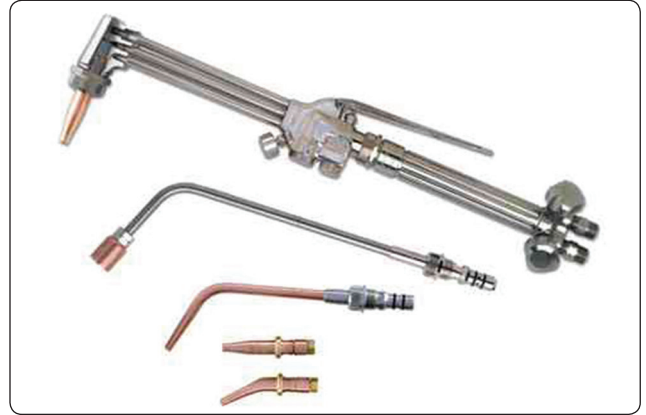

Figure 5-17. Torch handle with cutting, heating, and welding tips.

is too great, and holes are burned in the metal.

Torch tip sizes are designated by numbers. The manufacturer can provide a chart with recommended sizes for welding specific thicknesses of metal. With use, a torch tip becomes clogged with carbon deposits. If it is allowed to contact the molten pool, particles of slag may clog the tip. This may cause a backfire, which is a momentary backward flow of the gases at the torch tip. A backfire is rarely dangerous, but molten metal may be splattered when the flame pops. Tips should be cleaned with the proper size tip cleaner to avoid enlarging the tip opening.

### Welding Eyewear

Protective eyewear for use with oxy-fuel welding outfits is available in several styles and must be worn to protect the welder's eyes from the bright flame and flying sparks. This eyewear is not for use with arc welding equipment.

Some of the styles available have individual lenses and include goggles that employ a head piece and/or an elastic head strap to keep them snug around the eyes for protection from the occasional showering spark. [Figure 5-18] Another popular style is the rectangular eye shield that takes a standard 2-inch by 4.25-inch lens. This style is available with an elastic strap but is far more comfortable and better fitting when attached to a proper fitting adjustable headgear. It can be worn over prescription glasses, provides protection from



Figure 5-18. Welding goggles.

flying sparks, and accepts a variety of standard shade and color lenses. A clear safety glass lens is added in front of the shaded lens to protect it from damage. [Figure 5-19]

It was standard practice in the past to select a lens shade for gas welding based on the brightness of flame emitting from the torch. The darkest shade of lens showing a clear definition of the work was normally the most desirable. However, when flux was used for brazing and welding, the torch heat caused the sodium in the flux to give off a brilliant yellow-orange flare, hiding a clear view of the weld area and causing many eye problems.

Various types of lens and colors were tried for periods of time without much success. It was not until the late 1980s that TM Technologies developed and patented a new green glass designed especially for aluminum oxy-fuel welding. It not only eliminated the sodium orange flare completely, but also provided the necessary protection from ultraviolet, infrared, and blue light, and impact to meet the requirements of the American National Standards Institute (ANSI) Z87-1989 Safety Standards for a special purpose lens. This lens can be used for welding and brazing all metals using an oxy-fuel torch.

### ***Torch Lighters***

Torch lighters are called friction lighters or flint strikers. The lighter consists of a file-shaped piece of steel, usually recessed in a cuplike device, and a replaceable flint, which when drawn across the steel produces a shower of sparks to light the fuel gas. An open flame or match should never be used to light a torch, because accumulated gas may envelop the hand and when ignited cause a severe burn. [Figure 5-20]

### ***Filler Rod***

The use of the proper type of filler rod is very important for oxy-acetylene welding. This material adds not only reinforcement to the weld area, but also desired properties to the finished weld. By selecting the proper rod, tensile strength or ductility can be secured in a weld. Similarly, the proper rod can help retain the desired amount of corrosion resistance. In

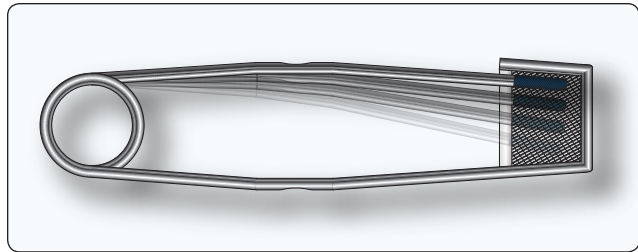

**Figure 5-20.** *Torch lighter.*

some cases, a suitable rod with a lower melting point helps to avoid cracks caused by expansion and contraction.

Welding rods may be classified as ferrous or nonferrous. Ferrous rods include carbon and alloy steel rods, as well as cast-iron rods. Nonferrous rods include brass, aluminum, magnesium, copper, silver, and their various alloys.

Welding rods are manufactured in standard 36-inch lengths and in diameters from  $\frac{1}{16}$ -inch to  $\frac{3}{8}$ -inch. The diameter of the rod to be used is governed by the thickness of the metals to be joined. If the rod is too small, it cannot conduct heat away from the puddle rapidly enough, and a burned hole results. A rod too large in diameter draws heat away and chills the puddle, resulting in poor penetration of the joined metal. All filler rods should be cleaned prior to use.

### **Equipment Setup**

Setting up acetylene welding equipment in preparation for welding should be accomplished in a systematic and definite order to avoid costly damage to equipment and compromising the safety of personnel.

### ***Gas Cylinders***

All cylinders should be stored and transported in the upright position, especially acetylene cylinders, because they contain an absorbent material saturated with liquid acetone. If the cylinder were laid on its side, allowing the acetone to enter and contaminate the regulator, hose, and torch, fuel starvation and a resultant flashback in the system could result. If an acetylene cylinder must be placed on its side for a period of time, it must be stored in the upright position for at least twice as long before being used. Gas cylinders should be secured, usually with a chain, in a permanent location or in a suitable mobile cart. The cylinder's protective steel cap should not be removed until the cylinder is put into service.

### ***Regulators***

Prior to installing the regulator on a gas cylinder, open the cylinder shutoff valve for an instant to blow out any foreign material that may be lodged in the outlet. Close the valve and wipe off the connection with a clean oil-free cloth. Connect the acetylene pressure regulator to the acetylene cylinder



**Figure 5-19.** *Gas welding eye shield attached to adjustable headgear.*

and tighten the left-hand nut. Connect the oxygen pressure regulator to the oxygen cylinder and tighten the right-hand nut. The connection fittings are brass and do not require a lot of torque to prevent them from leaking. At this time, check to ensure the adjusting screw on each pressure regulator is backed out by turning counterclockwise until it turns freely.

### ***Hoses***

Connect the red hose with the left-hand threads to the acetylene pressure regulator and the green hose with the right-hand threads to the oxygen pressure regulator. This is the location, between the regulator and hose, in which flashback arrestors should be installed. Again, because the fittings are brass and easily damaged, tighten only enough to prevent leakage.

Stand off to the side away from the face of the gauges. Now, very slowly open the oxygen cylinder valve and read the cylinder gauge to check the contents in the tank. The oxygen cylinder shutoff valve has a double seat valve and should be opened fully against its stop to seat the valve and prevent a leak. The acetylene cylinder shutoff valve should be slowly opened just enough to get the cylinder pressure reading on the regulator and then one half of a turn more. This allows a quick shutoff, if needed.

NOTE: As a recommended safety practice, the cylinders should not be depleted in content below 20 psi. This prevents the possible reverse flow of gas from the opposite tank.

Both hoses should be blown out before attaching to the torch. This is accomplished for each cylinder by turning the pressure adjusting screw in (clockwise) until the gas escapes, and then quickly backing the screw out (counterclockwise) to shut off the flow. This should be done in a well ventilated open space, free from sparks, flames, or other sources of ignition.

### ***Connecting Torch***

Connect the red hose with the left-hand thread connector nut to the left-hand thread fitting on the torch. Connect the green hose with the right-hand thread connector nut to the right-hand thread fitting on the torch. Close the valves on the torch handle and check all connections for leaks as follows:

- Turn in the adjusting screw on the oxygen pressure regulator until the working pressure indicates 10 psi. Turn in the adjusting screw on the acetylene pressure regulator until the working pressure indicates 5 psi.
- Back out both adjusting screws on the regulators and verify that the working pressure remains steady. If it drops and pressure is lost, a leak is indicated between the regulator and the torch.

- A general tightening of all connections should fix the leak. Repeat a check of the system.
- If a leak is still indicated by a loss in working pressure, a mixture of soapy water on all the connections reveals the source of the leak. Never check for a leak with a flame because a serious explosion could occur.

### ***Select the Tip Size***

Welding and cutting tips are available in a variety of sizes for almost any job, and are identified by number. The higher the number is, the bigger the hole in the tip is allowing more heat to be directed onto the metal and allowing thicker metal to be welded or cut.

Welding tips have one hole and cutting tips have a number of holes. The cutting tip has one large hole in the center for the cutting oxygen and a number of smaller holes around it that supply fuel, gas, and oxygen for the preheating flame. The selection of the tip size is very important, not only for the quality of the weld and/or the efficiency of the cutting process, but for the overall operation of the welding equipment and safety of the personnel using it.

Starvation occurs if torch tips are operated at less than the required volume of gas, leading to tip overheating and possible flashbacks. Incorrect tip size and obstructed tip orifices can also cause overheating and/or flashback conditions.

All fuel cylinders have a limited capacity to deliver gas to the tip. That capacity is further limited by the gas contents remaining in the cylinder and the temperature of the cylinder.

The following provides some recommended procedures to guard against overheating and flashbacks:

- Refer to the manufacturer's recommendations for tip size based on the metal's thickness.
- Use the recommended gas pressure settings for the tip size being used.
- Provide the correct volume of gas as recommended for each tip size.
- Do not use an excessively long hose, one with multiple splices, or one that may be too small in diameter and restrict the flow of gas.

NOTE: Acetylene is limited to a maximum continuous withdrawal rate of one-seventh of the cylinder's rated capacity when full. For example, an acetylene cylinder that has a capacity of 330 cubic feet has a maximum withdrawal of 47 cubic feet per hour. This is determined by dividing 330

(cylinder capacity) by 7 (one-seventh of the cylinder capacity). As a safety precaution, it is recommended that flashback arrestors be installed between the regulators and the gas supply hoses of all welding outfits. *Figure 5-21* shows recommended tip sizes of different manufacturers, for welding various thickness of metals.

### Adjusting the Regulator Working Pressure

The working pressure should be set according to the manufacturer's recommendation for the tip size that is being used to weld or cut. This is a recommended method that works for most welding and cutting operations.

In a well ventilated area, open the acetylene valve on the torch and turn the adjusting screw on the acetylene pressure regulator clockwise until the desired pressure is set. Close the acetylene valve on the torch. Then, set the oxygen pressure in the same manner by opening the oxygen valve on the torch and turning the adjusting screw clockwise on the oxygen regulator until desired pressure is set. Then, close the oxygen valve on the torch handle. With the working pressures set, the welding or cutting operation can be initiated.

Welding Tip Size Conversion Chart									
Wire Drill	Decimal Inch	Metric Equiv. (mm)	Smiths™ AW1A	Henrob/Dillion	Harris 15	Victor J Series	Meco N Midget™	Aluminum Thickness (in)	Steel Thickness (in)
97	0.0059	0.150						Foil	Foil
85	0.0110	0.279							
80	0.0135	0.343		#00			#00		
76	0.0200	0.508	AW200				#0		
75	0.0220	0.559		#0	#0	#000			.015
74	0.0225	0.572	AW20					.025	
73	0.0240	0.610					0.5		
72	0.0250	0.635		0.5					
71	0.0260	0.660	AW201		1				
70	0.0280	0.711				#00	1		.032
69	0.0292	0.742	AW202						
67	0.0320	0.813	AW203				1.5	.040	
66	0.0340	0.864		1					
65	0.0350	0.889			2	#0	2	.050	.046
63	0.0370	0.940	AW204				2.5		
60	0.0400	1.016				1			
59	0.0410	1.041		1.5					
58	0.0420	1.067			3		3		.062
57	0.0430	1.092	AW205						
56	0.0465	1.181	AW206			2	4	.063	
55	0.0520	1.321		2	4				.093
54	0.0550	1.397	AW207				4.5		
53	0.0595	1.511			5	3			.125
52	0.0635	1.613	AW208				5	.100	
51	0.0670	1.702			6				.187
49	0.0730	1.854	AW209	2.5		4	5.5		
48	0.0760	1.930			7			.188	.250
47	0.0780	1.981					6		
45	0.0820	2.083			8				.312
44	0.0860	2.184	AW210				6.5	.25	
43	0.0890	2.261			9	5	7		.375
42	0.0930	2.362		3					
40	0.0980	2.489			10				
36	0.1060	2.692				6			
35	0.1100	2.794			13				

Figure 5-21. Chart of recommended tip sizes for welding various thicknesses of metal.

## Lighting and Adjusting the Torch

With the proper working pressures set for the acetylene and oxygen, open the torch acetylene valve a quarter to a half turn. Direct the torch away from the body and ignite the acetylene gas with the flint striker. Open the acetylene valve until the black sooty smoke disappears from the flame. The pure acetylene flame is long, bushy, and has a yellowish color. Open the torch oxygen valve slowly and the flame shortens and turns to a bluish-white color that forms a bright inner luminous cone surrounded by an outer flame envelope. This is a neutral flame that should be set before either a carburizing or oxidizing flame mixture is set.

### Different Flames

The three types of flame commonly used for welding are neutral, carburizing, and oxidizing. Each serves a specific purpose. [Figure 5-22]

#### Neutral Flame

The neutral flame burns at approximately 5,850 °F at the tip of the inner luminous cone and is produced by a balanced mixture of acetylene and oxygen supplied by the torch. The neutral flame is used for most welding because it does not alter the composition of the base metal. When using this flame on steel, the molten metal puddle is quiet and clear, and the metal flows to give a thoroughly fused weld without burning or sparking.

#### Carburizing Flame

The carburizing flame burns at approximately 5,700 °F at the tip of the inner core. It is also referred to as a reducing flame because it tends to reduce the amount of oxygen in the iron oxides. The flame burns with a coarse rushing sound, and has a bluish-white inner cone, a white center cone, and a light blue outer cone.

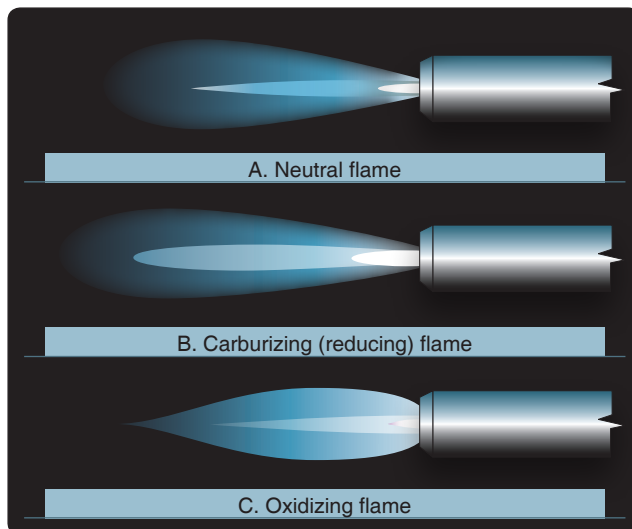

Figure 5-22. Oxy-acetylene flames.

The flame is produced by burning more acetylene than oxygen, and can be recognized by the greenish feathery tip at the end of the cone. The longer the feather, the more acetylene is in the mix. For most welding operations, the length of the feather should be about twice the length of the inner cone.

The carburizing flame is best used for welding high-carbon steels, for hard facing, and for welding such nonferrous alloys as aluminum, nickel, and Monel.

#### Oxidizing Flame

The oxidizing flame burns at approximately 6,300 °F and is produced by burning an excess of oxygen. It takes about two parts of oxygen to one part acetylene to produce this flame. It can be identified by the shorter outer flame and the small, white, inner cone. To obtain this flame, start with a neutral flame and then open the oxygen valve until the inner cone is about one-tenth of its original length. The oxidizing flame makes a hissing sound, and the inner cone is somewhat pointed and purplish in color at the tip.

The oxidizing flame does have some specific uses. A slightly oxidizing flame is used for bronze welding (brazing) of steel and cast iron. A stronger oxidizing flame is used for fusion welding of brass and bronze. If an oxidizing flame is used on steel, it causes the molten metal to foam, give off sparks, and burn.

#### Soft or Harsh Flames

With each size of tip, a neutral, carburizing, or oxidizing flame can be obtained. It is also possible to obtain a soft or harsh flame by decreasing or increasing the working pressure of both gases (observing the maximum working pressure of 15 psi for acetylene gas).

For some work, it may be desirable to have a soft or low velocity flame without a reduction of thermal output. This can be achieved by reducing the working pressure using a larger tip and closing the torch valves until the neutral flame is quiet and steady. It is especially desirable to use a soft flame when welding aluminum to avoid blowing holes in the metal when the puddle is formed.

#### Handling of the Torch

It should be cautioned that improper adjustment or handling of the torch may cause the flame to backfire or, in rare cases, to flashback. A backfire is a momentary backward flow of gases at the torch tip that causes the flame to go out. A backfire may be caused by touching the tip against the work, overheating the tip, by operating the torch at other than recommended pressures, by a loose tip or head, or by dirt or slag in the end of the tip, and may cause molten metal to be splattered when the flame pops.

A flashback is dangerous because it is the burning of gases within the torch. It is usually caused by loose connections, improper pressures, or overheating of the torch. A shrill hissing or squealing noise accompanies a flashback, and unless the gases are turned off immediately, the flame may burn back through the hose and regulators causing great damage and personal injury. The cause of the flashback should always be determined and the problem corrected before relighting the torch. All gas welding outfits should have a flashback arrestor.

## Oxy-acetylene Cutting

Cutting ferrous metals by the oxy-acetylene process is primarily the rapid burning or oxidizing of the metal in a localized area. This is a quick and inexpensive way to cut iron and steel where a finished edge is not required.

*Figure 5-23* shows an example of a cutting torch. It has the conventional oxygen and acetylene valves in the torch handle that control the flow of the two gases to the cutting head. It also has an oxygen valve below the oxygen lever on the cutting head so that a finer adjustment of the flame can be obtained.

The size of the cutting tip is determined by the thickness of the metal to be cut. Set the regulators to the recommended working pressures for the cutting torch based on the tip size selected. Before beginning any cutting operation, the area should be clear of all combustible material and the proper protective equipment should be worn by personnel engaged in the cutting operation.

The flame for the torch in *Figure 5-23* is set by first closing the oxygen valve below the cutting lever and fully opening the oxygen valve on the handle. (This supplies the high-pressure oxygen blast when the cutting lever is actuated.) The acetylene valve on the handle is then opened and the torch is lit with a striker. The acetylene flame is increased until the black soot is gone. Then, open the oxygen valve below the cutting lever and adjust the flame to neutral. If more heat is needed, open the valves to add more acetylene and oxygen. Actuate the cutting lever and readjust the preheat flame to neutral if necessary.



**Figure 5-23.** Cutting torch with additional tools.

The metal is heated to a bright red color (1,400 °F–1,600 °F, which is the kindling or ignition temperature) by the preheat orifices in the tip of the cutting torch. Then, a jet of high-pressure oxygen is directed against it by pressing the oxygen lever on the torch. This oxygen blast combines with the red-hot metal and forms an intensely hot molten oxide that is blown down the sides of the cut. As the torch is moved along the intended cut line, this action continues heating the metal in its path to the kindling temperature. The metal, thus heated, also burns to an oxide that is blown away to the underside of the piece.

Proper instruction and practice provides the knowledge and skill to become proficient in the technique needed to cut with a torch. Hold the torch in either hand, whichever is most comfortable. Use the thumb of that hand to operate the oxygen cutting lever. Use the other hand to rest the torch on and steady it along the cut line.

Begin at the edge of the metal and hold the tip perpendicular to the surface, preheating until the spot turns bright red. Lightly depress the cutting lever to allow a shower of sparks and molten metal to blow through the cut. Fully depress the cutting lever and move the torch slowly in the direction of the intended cut.

Practice and experience allow the technician to learn how to judge the speed at which to move the torch. It should be just fast enough to allow the cut to penetrate completely without excessive melting around the cut. If the torch is moved too fast, the metal will not be preheated enough, and the cutting action stops. If this happens, release the cutting lever, preheat the cut to bright red, depress the lever, and continue with the cut.

## Shutting Down the Gas Welding Equipment

Shutting down the welding equipment is fairly simple when some basic steps are followed:

- Turn off the flame by closing the acetylene valve on the torch first. This shuts the flame off quickly. Then, close the oxygen valve on the torch handle. Also, close oxygen valve on cutting torch, if applicable.
- If the equipment is not used in the immediate future (approximately the next 30 minutes), the valves on the acetylene and oxygen cylinders should be closed and pressure relieved from the hoses.
- In a well-ventilated area, open the acetylene valve on the torch and allow the gas to escape to the outside atmosphere, and then close the valve.
- Open the oxygen valve on the torch, allow the gas to escape, and then close the valve.

- Close both the acetylene and oxygen regulators by backing out the adjusting screw counterclockwise until loose.
- Carefully coil the hose to prevent kinking and store it to prevent damage to the torch and tip.

## Gas Welding Procedures and Techniques

The material to be welded, the thickness of the metal, the type of joint, and the position of the weld dictates the procedure and technique to be used.

When light-gauge metal is welded, the torch is usually held with the hose draped over the wrist. [Figure 5-24] To weld heavy materials, the more common grip may provide better control of the torch. [Figure 5-25]

The torch should be held in the most comfortable position that allows the tip to be in line with the joint to be welded, and inclined between 30° and 60° from the perpendicular. This position preheats the edges just ahead of the molten puddle. The best angle depends on the type of weld, the amount of preheating required, and the thickness and type of metal. The thicker the metal, the more vertical the torch must be for proper heat penetration. The white cone of the flame should be held about 1/8-inch from the surface of the metal.

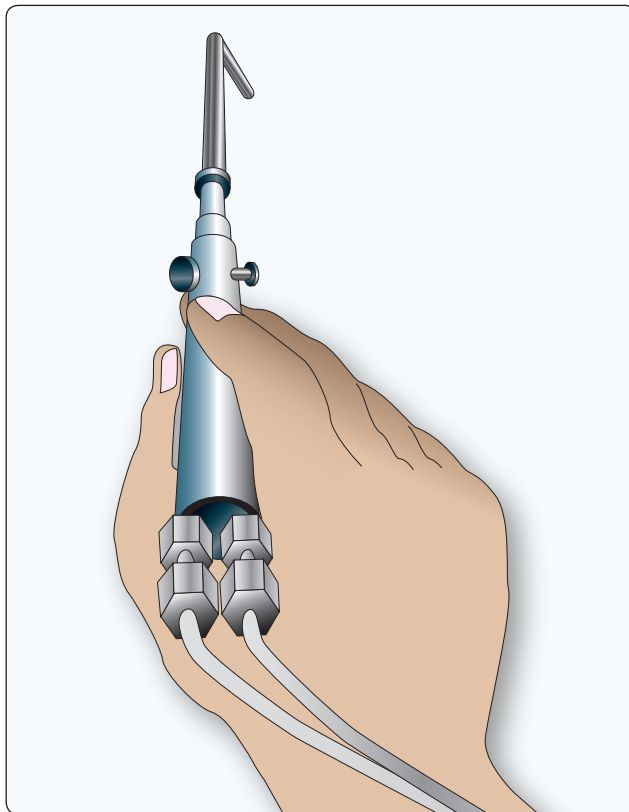

Figure 5-24. Hand position for light-gauge materials.

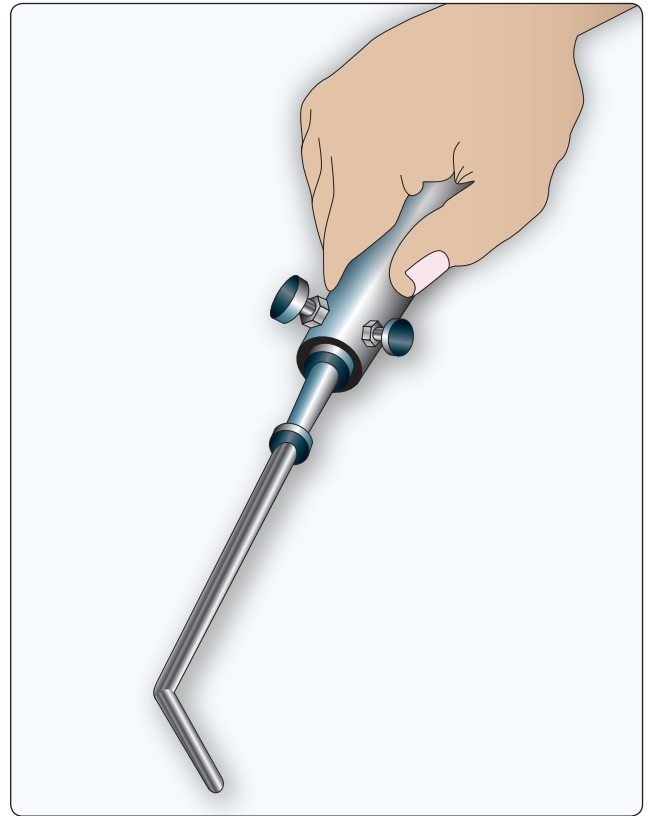

Figure 5-25. Hand position for heavy-gauge materials.

Welding can be performed by pointing the torch flame in the direction that the weld is progressing. This is referred to as forehand welding, and is the most commonly used method for lighter tubing and sheet metal. The filler rod is kept ahead of the tip in the direction the weld is going and is added to the puddle.

For welding thick metals or heavy plate, a technique called backhand welding can be used. In this method, the torch flame is pointed back toward the finished weld and the filler rod is added between the flame and the weld. This method provides a greater concentration of heat for welding thicker metals and would rarely be used in aircraft maintenance.

### Puddle

If the torch is held in the correct position, a small puddle of molten metal forms. The puddle should be centered in the joint and composed of equal parts of those pieces being welded. After the puddle appears, the tip should be moved in a semicircular arc or circular motion equally between the pieces to ensure an even distribution of heat.

### Adding Filler Rod to the Puddle

As the metal melts and the puddle forms, filler rod is needed to replace the metal that flows out from around the joint.

The rod is added to the puddle in the amount that provides for the completed fillet to be built up about one-fourth the thickness of the base metal. The filler rod selected should be compatible with the base metal being welded.

### **Correct Forming of a Weld**

The form of the weld metal has considerable bearing upon the strength and fatigue resistance of a joint. The strength of an improperly made weld is usually less than the strength for which the joint was designed. Low-strength welds are generally the result of insufficient penetration; undercutting of the base metal at the toe of the weld; poor fusion of the weld metal with the base metal; trapped oxides, slag, or gas pockets in the weld; overlap of the weld metal on the base metal; too much or too little reinforcement; or overheating of the weld.

### **Characteristics of a Good Weld**

A completed weld should have the following characteristics:

1. The seam should be smooth, the bead ripples evenly spaced, and of a uniform thickness.
2. The weld should be built up, slightly convex, thus providing extra thickness at the joint.
3. The weld should taper off smoothly into the base metal.
4. No oxide should be formed on the base metal close to the weld.
5. The weld should show no signs of blowholes, porosity, or projecting globules.
6. The base metal should show no signs of burns, pits, cracks, or distortion.

Although a clean, smooth weld is desirable, this characteristic does not necessarily mean that the weld is a good one; it may be dangerously weak inside. However, when a weld is rough, uneven, and pitted, it is almost always unsatisfactory inside. Welds should never be filed to give them a better appearance, since filing deprives the weld of part of its strength. Welds should never be filled with solder, brazing material, or filler of any sort.

When it is necessary to reweld a joint, all old weld material must be removed before the operation is begun. It must be remembered that reheating the area may cause the base metal to lose some of its strength and become brittle. This should not be confused with a post-weld heat treatment that does not raise the metal to a high enough temperature to cause harm to the base material.

## **Oxy-Acetylene Welding of Ferrous Metals Steel (Including SAE 4130)**

Low-carbon steel, low-alloy steel (e.g., 4130), cast steel, and wrought iron are easily welded with the oxy-acetylene flame. Low-carbon and low-alloy steels are the ferrous materials that are gas welded most frequently. As the carbon content of steel increases, it may be repaired by welding using specific procedures for various alloy types. Factors involved are the carbon content and hardenability. For corrosion-resistant and heat-resistant nickel chromium steels, the allowed weldability depends upon their stability, carbon content, and reheat treatment.

The Society of Automotive Engineers (SAE) and the American Iron and Steel Institute (AISI) provide a designation system that is an accepted standard for the industry. SAE 4130 is an alloy steel that is an ideal material for constructing fuselages and framework on small aircraft; it is also used for motorcycle and high-end bicycle frames and race car frames and roll cages. The tubing has high tensile strength, malleability, and is easy to weld.

The number '4130' is also an AISI 4-digit code that defines the approximate chemical composition of the steel. The '41' indicates a low-alloy steel containing chromium and molybdenum (chromoly) and the '30' designates a carbon content of 0.3 percent. 4130 steel also contains small amounts of manganese, phosphorus, sulfur, and silicon, but like all steels, it contains mostly iron.

In order to make a good weld, the carbon content of the steel must not be altered to any appreciable degree, nor can other atmospheric chemical constituents be added to or subtracted from the base metal without seriously altering the properties of the metal. However, many welding filler wires do contain constituents different from the base material for specific reasons, which is perfectly normal and acceptable if approved materials are used. Molten steel has a great affinity for carbon, oxygen, and nitrogen combining with the molten puddle to form oxides and nitrates, both of which lower the strength of steel. When welding with an oxy-acetylene flame, the inclusion of impurities can be minimized by observing the following precautions:

- Maintain an exact neutral flame for most steels and a slight excess of acetylene when welding alloys with a high nickel or chromium content, such as stainless steel.
- Maintain a soft flame and control the puddle.



- Maintain a flame sufficient to penetrate the metal and manipulate it so that the molten metal is protected from the air by the outer envelope of flame.
- Keep the hot end of the welding rod in the weld pool or within the flame envelope.
- When the weld is complete and still in the red heat, circle the outer envelope of the torch around the entire weldment to bring it evenly to a dull red. Slowly back the torch away from the weldment to ensure a slow cooling rate.

### Chrome Molybdenum

The welding technique for chrome molybdenum (chrome-moly) is practically the same as that for carbon steels, except for sections over  $\frac{3}{16}$ -inch thick. The surrounding area must be preheated to a temperature between 300 °F and 400 °F before beginning to weld. If this is not done, the sudden quenching of the weld area after the weld is complete may cause a brittle grain structure of untempered martensite that must be eliminated with post-weld heat treatments. Untempered martensite is a glass-like structure that takes the place of the normally ductile steel structure and makes the steel prone to cracking, usually near the edge of the weld. This preheating also helps to alleviate some of the distortion caused by welding along with using proper practices found in other sections of this chapter.

A soft neutral flame should be used for welding and must be maintained during the process. If the flame is not kept neutral, an oxidizing flame may cause oxide inclusions and fissures. A carburizing flame makes the metal more hardenable by raising the carbon content. The volume of the flame must be sufficient to melt the base metal, but not hot enough to overheat the base metal and cause oxide inclusions or a loss of metal thickness. The filler rod should be compatible with the base metal. If the weld requires high strength, special low-alloy filler is used, and the piece is heat treated after welding.

It may be advantageous to TIG weld 4130 chrome-moly sections over 0.093-inch thickness followed by a proper post-weld heat treatment as this can result in less overall distortion. However, do not eliminate the post-weld heat treatment as doing so could severely limit the fatigue life of the weldment due to the formed martensitic grain structure.

### Stainless Steel

The procedure for welding stainless steel is basically the same as that for carbon steels. There are, however, some special precautions you must take to obtain the best results.

Only stainless steel used for nonstructural members of aircraft can be welded satisfactorily. The stainless steel used for

structural components is cold worked or cold rolled and, if heated, loses some of its strength. Nonstructural stainless steel is obtained in sheet and tubing form and is often used for exhaust collectors, stacks, or manifolds. Oxygen combines very readily with this metal in the molten state, and you must take extreme care to prevent this from occurring.

A slightly carburizing flame is recommended for welding stainless steel. The flame should be adjusted so that a feather of excess acetylene, about  $\frac{1}{16}$ -inch long, forms around the inner cone. Too much acetylene, however, adds carbon to the metal and causes it to lose its resistance to corrosion. The torch tip size should be one or two sizes smaller than that prescribed for a similar gauge of low-carbon steel. The smaller tip lessens the chances of overheating and subsequent loss of the corrosion-resistant qualities of the metal.

To prevent the formation of chromium oxide, a specially compounded flux for stainless steel, should be used. The flux, when mixed with water, can be spread on the underside of the joint and on the filler rod. Since oxidation must be avoided as much as possible, use sufficient flux. The filler rod used should be of the same composition as the base metal.

When welding, hold the filler rod within the envelope of the torch flame so that the rod is melted in place or melted at the same time as the base metal. Add the filler rod by allowing it to flow into the molten pool. Do not stir the weld pool, because air enters the weld and increases oxidation. Avoid rewelding any portion or welding on the reverse side of the weld, which results in warping and overheating of the metal.

Another method used to keep oxygen from reaching the metal is to surround the weld with a blanket of inert gas. This is done by using a TIG welder to perform welding of stainless steel. It is a recommended method for excellent weld results and does not require the application of flux and its subsequent cleanup.

### Oxy-Acetylene Welding of Nonferrous Metals

Nonferrous metals are those that contain no iron. Examples of nonferrous metals are lead, copper, silver, magnesium, and the most important in aircraft construction, aluminum. Some of these metals are lighter than the ferrous metals, but in most cases, they are not as strong. Aluminum manufacturers have compensated for the lack of strength of pure aluminum by alloying it with other metals or by cold working it. For still greater strength, some aluminum alloys are also heat treated.

## Aluminum Welding

Gas welding of certain aluminum alloys can be accomplished successfully, but it requires some practice and the appropriate equipment to produce a successful weld. Before attempting to weld aluminum for the first time, become familiar with how the metal reacts under the welding flame.

A good example for practice and to see how aluminum reacts to a welding flame, heat a piece of aluminum sheet on a welding bench. Hold a torch with a neutral flame perpendicular to the sheet and bring the tip of the inner cone almost in contact with the metal. Observe that the metal suddenly melts away, almost without any indication, and leaves a hole in the metal. Now repeat the operation, only this time hold the torch at an angle of about 30° to the surface. This allows for better control of the heat and allows the surface metal to melt without forming a hole. Practice by slowly moving the flame along the surface until the puddle can be controlled without melting holes. Once that is mastered, practice on flanged joints by tacking and welding without filler rod. Then, try welding a butt joint using flux and filler rod. Practice and experience provides the visual indication of the melting aluminum so that a satisfactory weld can be performed.

Aluminum gas welding is usually confined to material between 0.031-inch and 0.125-inch in thickness. The weldable aluminum alloys used in aircraft construction are 1100, 3003, 4043, and 5052. Alloy numbers 6053, 6061, and 6151 can also be welded, but since these alloys are in the heat-treated condition, welding should not be done unless the parts can be reheat treated.

Proper preparation prior to welding any metal is essential to produce a satisfactory weld. This preparation is especially critical during oxy-acetylene welding of aluminum. Select the proper torch tip for the thickness of metal being welded. Tip selection for aluminum is always one size larger than one would normally choose for the same thickness in a steel sheet. A rule of thumb:  $\frac{3}{4}$  metal thickness = tip orifice.

Set the proper regulator pressure using the following method for oxy-acetylene welding of aluminum. This method has been used by all aircraft factories since World War II. Start by slowly opening the valve on the oxygen cylinder all the way until it stops to seat the upper packing. Now, barely crack open the acetylene cylinder valve until the needle on the gauge jumps up, then open one-quarter turn more. Check the regulators to ensure the adjusting screws are turned counterclockwise all the way out and loose. Now, open both torch valves wide open, about two full turns (varies with the torch model). Turn the acetylene regulator by adjusting the screw until the torch blows a light puff at a two-inch distance.

Now, hold the torch away from the body and light it with the striker, adjusting the flame to a bright yellow bushy flame with the regulator screw. Add oxygen by slowly turning in the oxygen regulator screw to get a loud blue flame with a bright inner cone, perhaps a bit of the “fuel-rich” feather or carburizing secondary cone. By alternately turning in each of the torch valves a little bit, the flame setting can be lowered to what is needed to either tack or weld.

Special safety eyewear must also be used to protect the welder and provide a clear view through the yellow-orange flare given off by the incandescing flux. Special purpose green-glass lens have been designed and patented especially for aluminum oxy-fuel welding by TM Technologies. These lenses cut the sodium orange flare completely and provide the necessary protection from ultraviolet, infrared, blue light, and impact. They meet safety standard ANSI Z87-1989 for a special-purpose lens.

Apply flux either to the material, the filler, or both if needed. The aluminum welding flux is a white powder mixed one part powder to two parts clean spring or mineral water. (Do not use distilled water.) Mix a paste that can be brushed on the metal. Heating the filler or the part with the torch before applying the flux helps the flux dry quickly and not pop off when the torch heat approaches. Proper safety precautions, such as eye protection, adequate ventilation, and avoiding the fumes are recommended.

The material to be welded must be free of oil or grease. It should be cleaned with a solvent; the best being denatured isopropyl (rubbing) alcohol. A stainless toothbrush should be used to scrub off the invisible aluminum oxide film just prior to welding but after cleaning with alcohol. Always clean the filler rod or filler wire prior to use with alcohol and a clean cloth.

Make the best possible fit-up for joints to avoid large gaps and select the appropriate filler metal that is compatible with the base metal. The filler should not be a larger diameter than the pieces to be welded. [Figure 5-26]

Begin by tacking the pieces. The tacks should be applied 1–1½-inches apart. Tacks are done hot and fast by melting the edges of the metal together, if they are touching, or by adding filler to the melting edges when there is a gap. Tacking requires a hotter flame than welding. So, if the thickness of the metal being welded is known, set the length of the inner cone of the flame roughly three to four metal thicknesses in length for tacking. (Example: .063 aluminum sheet =  $\frac{3}{16}$ – $\frac{1}{4}$  inch inner cone.)

Filler Metal Selection Chart					
Base Metals	1100 3003	5005	5052	5086 DO NOT GAS WELD	6061
6061	4043 (a)	4043 (a)	5356	5356	4043 (a)
	4047	5183	5183	5183	4047
		5356	5554	5356	5556
		5556	5556	5556	5183
		5554 (d)	5654 (d)	5654 (c)	5554 (d)
		5654 (c)	4043 (a)		
5086 DO NOT GAS WELD	5356	5356	5356	5356	
	4043 (a)	5183	5183	5183	
		5556	5556	5556	
5052	5183	4043 (a)	5654 (c)		
	5356	5183	5183		
	5556	5356	5356		
	4043 (a,b)	5556	5556		
		4047	5554 (d)		
		4043 (a)			
5005	5183	5183			
	5356	5356			
	5556	4043 (a,b)			
	4043 (a,b)				
1100 3003	1110				
	4043 (a)				

**For explanation of (a. b. c. d) see below**

Copyright © 1997 TM Technologies

(a) 4043, because of its Si content, is less susceptible to hot cracking but has less ductility and may crack when planished.  
(b) For applications at sustained temperatures above ISOF because of intergranular corrosion.  
(c) Low temperature service at ISOF and below.  
(d) 5554 is suitable for elevated temperatures.

NOTE: When choosing between 5356, 5183, 5556, be aware that 5356 is the weakest and 5556 is the strongest, with 5183 in between. Also, 4047 has more Si than 4043, therefore less sensitivity to hot cracking, slightly higher weld shear strength, and less ductility.

**Figure 5-26.** Filler metal selection chart.

Once the edges are tacked, begin welding by either starting at the second tack and continuing on, or starting the weld one inch in from the end and then welding back to the edge of the sheet. Allow this initial skip-weld to chill and solidify. Then, begin to weld from the previous starting point and continue all the way to the end. Decrease the heat at the end of the seam to allow the accumulated heat to dissipate. The last inch or so is tricky and must be dabbed to prevent blow-through. (Dabbing is the adding of filler metal in the molten pool while controlling the heat on the metal by raising and lowering the torch.)

Weld bead appearance, or making ringlets, is caused by the movement of the torch and dabbing the filler metal. If the torch and add filler metal is moved at the same time, the

ringlet is more pronounced. A good weld has a bead that is not too proud and has penetration that is complete.

Immediately after welding, the flux must be cleaned by using hot (180 °F) water and the stainless steel brush, followed by liberal rinsing with fresh water. If only the filler was fluxed, the amount of cleanup is minimal. All flux residues must be removed from voids and pinholes. If any particular area is suspect to hidden flux, pass a neutral flame over it and a yellow-orange incandescence will betray hiding residues.

Proper scrubbing with an etching solution and waiting no longer than 20 minutes to prime and seal avoids the lifting, peeling, or blistering of the finished topcoat.

### Magnesium Welding

Gas welding of magnesium is very similar to welding aluminum using the same equipment. Joint design also follows similar practice to aluminum welding. Care must be taken to avoid designs that may trap flux after the welding is completed, with butt and edge welds being preferred. Of special interest is the high expansion rate of magnesium-based alloys, and the special attention that must be given to avoid stresses being set up in the parts. Rigid fixtures should be avoided; use careful planning to eliminate distortion.

In most cases, filler material should match the base material in alloy. When welding two different magnesium alloys together, the material manufacturer should be consulted for recommendations. Aluminum should never be welded to magnesium. As in aluminum welding, a flux is required to break down the surface oxides and ensure a sound weld. Fluxes sold specifically for the purpose of fusion welding magnesium are available in powder form and are mixed with water in the same manner as for aluminum welding. Use the minimum amount of flux necessary to reduce the corrosive effects and cleaning time required after the weld is finished. The sodium-flare reducing eye protection used for aluminum welding is of the same benefit on magnesium welding.

Welding is done with a neutral flame setting using the same tip size for aluminum welding. The welding technique follows the same pattern as aluminum with the welding being completed in a single pass on sheet gauge material. Generally, the TIG process has replaced gas welding of magnesium due to the elimination of the corrosive flux and its inherent limitations on joint design.

### Brazing and Soldering

#### Torch Brazing of Steel

The definition of joining two pieces of metal by brazing typically meant using brass or bronze as the filler metal.

However, that definition has been expanded to include any metal joining process in which the bonding material is a nonferrous metal or alloy with a melting point higher than 800 °F, but lower than that of the metals being joined.

Brazing requires less heat than welding and can be used to join metals that may be damaged by high heat. However, because the strength of a brazed joint is not as great as that of a welded joint, brazing is not used for critical structural repairs on aircraft. Also, any metal part that is subjected to a sustained high temperature should not be brazed.

Brazing is applicable for joining a variety of metals, including brass, copper, bronze and nickel alloys, cast iron, malleable iron, wrought iron, galvanized iron and steel, carbon steel, and alloy steels. Brazing can also be used to join dissimilar metals, such as copper to steel or steel to cast iron.

When metals are joined by brazing, the base metal parts are not melted. The brazing metal adheres to the base metal by molecular attraction and intergranular penetration; it does not fuse and amalgamate with them.

In brazing, the edges of the pieces to be joined are usually beveled as in welding steel. The surrounding surfaces must be cleaned of dirt and rust. Parts to be brazed must be securely fastened together to prevent any relative movement. The strongest brazed joint is one in which the molten filler metal is drawn in by capillary action, requiring a close fit.

A brazing flux is necessary to obtain a good union between the base metal and the filler metal. It destroys the oxides and floats them to the surface, leaving a clean metal surface free from oxidation. A brazing rod can be purchased with a flux coating already applied, or any one of the numerous fluxes available on the market for specific application may be used. Most fluxes contain a mixture of borax and boric acid.

The base metal should be preheated slowly with a neutral soft flame until it reaches the flowing temperature of the filler metal. If a filler rod that is not precoated with flux is used, heat about 2 inches of the rod end with the torch to a dark purple color and dip it into the flux. Enough flux adheres to the rod that it is unnecessary to spread it over the surface of the metal. Apply the flux-coated rod to the red-hot metal with a brushing motion, using the side of the rod; the brass flows freely into the steel. Keep the torch heat on the base metal to melt the filler rod. Do not melt the rod with the torch. Continue to add the rod as the brazing progresses, with a rhythmic dipping action so that the bead is built to a uniform width and height. The job should be completed rapidly and with the fewest possible passes of the rod and torch.

Notice that some metals are good conductors of heat and dissipate the heat more rapidly away from the joint. Other metals are poor conductors that tend to retain the heat and overheat readily. Controlling the temperature of the base metal is extremely important. The base metal must be hot enough for the brazing filler to flow, but never overheated to the filler boiling point. This causes the joint to be porous and brittle.

The key to even heating of the joint area is to watch the appearance of the flux. The flux should change appearance uniformly when even heat is being applied. This is especially important when joining two metals of different mass or conductivity.

The brazing rod melts when applied to the red-hot base metal and runs into the joint by capillary attraction. (Note that molten brazing filler metal tends to flow toward the area of higher temperature.) In a torch heated assembly, the outer metal surfaces are slightly hotter than the interior joint surfaces. The filler metal should be deposited directly adjacent to the joint. Where possible, the heat should be applied to the assembly on the side opposite to where the filler is applied because the filler metal tends to flow toward the source of greater heat.

After the brazing is complete, the assembly or component must be cleaned. Since most brazing fluxes are water soluble, a hot water rinse (120 °F or hotter) and a wire brush remove the flux. If the flux was overheated during the brazing process, it usually turns green or black. In this case, the flux needs to be removed with a mild acid solution recommended by the manufacturer of the flux in use.

### **Torch Brazing of Aluminum**

Torch brazing of aluminum is done using similar methods as brazing of other materials. The brazing material itself is an aluminum/silicon alloy having a slightly lower melting temperature than the base material. Aluminum brazing occurs at temperatures over 875 °F, but below the melting point of the parent metal. This is performed with a specific aluminum brazing flux. Brazing is best suited to joint configurations that have large surface areas in contact, such as the lap, or for fitting fuel tank bungs and fittings. Either acetylene or hydrogen may be used as fuel gas, both being used for production work for many years. Using eye protection that reduces the sodium flare, such as the TM2000 lens, is recommended.

When using acetylene, the tip size is usually the same, or one size smaller than that used for welding of aluminum. A 1–2X reducing flame is used to form a slightly cooler flame, and the torch is held back at a greater distance using the outer envelope

as the heat source rather than the inner cone. Prepare the flux and apply in the same manner as the aluminum welding flux, fluxing both the base metal and filler material. Heat the parts with the outer envelope of the flame, watching for the flux to begin to liquefy; the filler may be applied at that point. The filler should flow easily. If the part gets overheated, the flux turns brown or grey. If this happens, reclean and re-flux the part before continuing. Brazing is more easily accomplished on 1100, 3003, and 6061 aluminum alloys. 5052 alloy is more difficult; proper cleaning and practice are vital. There are brazing products sold that have the flux contained in hollow spaces in the filler metal itself, which typically work only on 1100, 3003, and 6061 alloys as the flux is not strong enough for use on 5052. Cleaning after brazing is accomplished the same as with oxy-fuel welding of aluminum, using hot water and a clean stainless brush. The flux is corrosive, so every effort should be made to remove it thoroughly and quickly after the brazing is completed.

### **Soldering**

Soft solder is chiefly used to join copper and brass where a leak proof joint is desired, and sometimes for fitting joints to promote rigidity and prevent corrosion. Soft soldering is generally performed only in minor repair jobs. Soft solder is also used to join electrical connections. It forms a strong union with low electrical resistance.

Soft soldering does not require the heat of an oxy-fuel gas torch and can be performed using a small propane or MAPP® torch, an electrical soldering iron, or in some cases, a soldering copper, that is heated by an outside source, such as an oven or torch. The soft solders are chiefly alloys of tin and lead. The percentages of tin and lead vary considerably in the various solders with a corresponding change in their melting points ranging from 293 °F to 592 °F. Half-and-half (50/50) is the most common general-purpose solder. It contains equal portions of tin and lead and melts at approximately 360 °F.

To get the best results for heat transfer when using an electrical soldering iron or a soldering copper, the tip must be clean and have a layer of solder on it. This is usually referred to as being tinned. The hot iron or copper should be fluxed and the solder wiped across the tip to form a bright, thin layer of solder.

Flux is used with soft solder for the same reasons as with brazing. It cleans the surface area to be joined and promotes the flow by capillary action into the joint. Most fluxes should be cleaned away after the job is completed because they cause corrosion. Electrical connections should be soldered only with soft solder containing rosin. Rosin does not corrode the electrical connection.

### ***Aluminum Soldering***

The soldering of aluminum is much like the soldering of other metals. The use of special aluminum solders is required, along with the necessary flux. Aluminum soldering occurs at temperatures below 875 °F. Soldering can be accomplished using the oxy-acetylene, oxy-hydrogen, or even an air-propane torch setup. A neutral flame is used in the case of either oxy-acetylene or oxy-hydrogen. Depending on the solder and flux type, most common aluminum alloys can be soldered. Being of lower melting temperature, a tip one or two sizes smaller than required for welding is used, along with a soft flame setting.

Joint configurations for aluminum soldering follow the same guidelines as any other base material. Lap joints are preferred to tee or butt joints due to the larger surface contact area. However parts, such as heat exchanger tubes, are a common exception to this.

Normally, the parts are cleaned as for welding or brazing, and the flux is applied according to manufacturer's instructions. The parts are evenly heated with the outer envelope of the flame to avoid overheating the flux, and the solder is applied in a fashion similar to that for other base metals. Cleaning after soldering may not be required to prevent oxidation because some fluxes are not corrosive. However, it is always advisable to remove all flux residues after soldering.

Aluminum soldering is commonly used in such applications as the repair of heat exchanger or radiator cores originally using a soldered joint. It is not, however, to be used as a direct replacement repair for brazing or welding.

### ***Silver Soldering***

The principle use of silver solder in aircraft work is in the fabrication of high-pressure oxygen lines and other parts that must withstand vibration and high temperatures.

Silver solder is used extensively to join copper and its alloys, nickel and silver, as well as various combinations of these metals and thin steel parts. Silver soldering produces joints of higher strength than those produced by other brazing processes.

Flux must be used in all silver soldering operations to ensure the base metal is chemically clean. The flux removes the film of oxide from the base metal and allows the silver solder to adhere to it.

All silver solder joints must be physically, as well as chemically, clean. The joint must be free of dirt, grease, oil, and/or paint. After removing the dirt, grease, etc., any oxide (rust and/or corrosion) should be removed by grinding or filing the piece until bright metal can be seen. During the soldering operation, the flux continues to keep the oxide away from the metal and aid in the flow of the solder.

The three recommended types of joint for silver soldering are lap, flanged, and edge. With these, the metal is formed to furnish a seam wider than the base metal thickness and provide the type of joint that holds up under all types of loads. [Figure 5-27]

The oxy-acetylene flame for silver soldering should be a soft neutral or slightly reducing flame. That is, a flame with a slight excess of acetylene. During both preheating and application of the solder, the tip of the inner cone of the flame should be held about 1/2-inch from the work. The flame should be kept moving so that the metal does not overheat.

When both parts of the base metal are at the correct temperature, the flux flows and solder can be applied directly adjacent to the edge of the seam. It is necessary to simultaneously direct the flame over the seam and keep it moving so that the base metal remains at an even temperature.

### Gas Tungsten Arc Welding (TIG Welding)

The TIG process as it is known today is a combination of the work done by General Electric in the 1920s to develop the basic process, the work done by Northrop in the 1940s to develop the torch itself, and the use of helium-shielding gas and a tungsten electrode. The process was developed for welding magnesium in the Northrop XP-56 flying wing to eliminate the corrosion and porosity issues with the atomic hydrogen process they had been using with a boron flux. It was not readily used on other materials until the late 1950s when it found merit in welding space-age super alloys. It was also later used on other metals, such as aluminum and steel, to a much greater degree.

Modern TIG welding machines are offered in DC, AC, or with AC/DC configurations, and use either transformer or inverter-based technology. Typically, a machine capable of AC output is required for aluminum. The TIG torch itself has

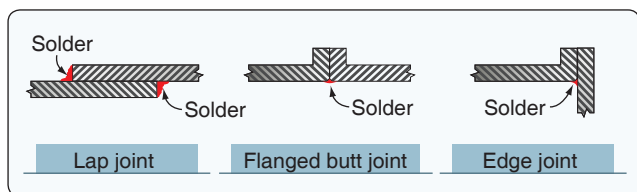

Figure 5-27. Silver solder joints.

changed little since the first Northrop patent. TIG welding is similar to oxy-fuel welding in that the heat source (torch) is manipulated with one hand, and the filler, if used, is manipulated with the other. A distinct difference is to control the heat input to the metal. The heat control may be preset and fixed by a machine setting or variable by use of a foot pedal or torch-mounted control.

Several types of tungsten electrode are used with the TIG welder. Thoriated and zirconiated electrodes have better electron emission characteristics than pure tungsten, making them more suitable for DC operations on transformer-based machines, or either AC or DC with the newer inverter-based machines. Pure tungsten provides a better current balance with AC welding with a transformer based machine, which is advantageous when welding aluminum and magnesium. The equipment manufacturers' suggestions for tungsten type and form should be followed as this is an ever changing part of the TIG technology.

The shape of the electrode used in the TIG welding torch is an important factor in the quality and penetration of the weld. The tip of the electrode should be shaped on a dedicated grinding stone or a special-purpose tungsten grinder to avoid contaminating the electrode. The grinding should be done longitudinally, not radially, with the direction of stone travel away from the tip. Figure 5-28 shows the effects of a sharp versus blunt electrode with transformer-based machines.

When in doubt, consult the machine manufacturer for the latest up-to-date suggestions on tungsten preparation or if problems arise.

The general guidelines for weld quality, joint fit prior to welding, jiggling, and controlling warp all apply to this process in the same regard as any other welding method. Of particular note are the additional process steps that sometimes must be taken to perform a quality weld; these are dealt within their appropriate sections.

Sharper Electrode	Blunter Electrode
Easy arc starting	Usually harder to start the arc
Handles less amperage	Handles more amperage
Wider arc shape	Narrower arc shape
Good arc stability	Potential for arc wander
Less weld penetration	Better weld penetration
Shorter electrode life	Longer electrode life

Figure 5-28. Effects of sharp and blunt electrodes.

## **TIG Welding 4130 Steel Tubing**

Welding 4130 with TIG is not much different than welding other steels as far as technique is concerned. The following information generally addresses material under 0.120-inch thick.

Clean the steel of any oil or grease and use a stainless steel wire brush to clean the work piece prior to welding. This is to prevent porosity and hydrogen embrittlement during the welding process. The TIG process is highly susceptible to these problems, much more so than oxy-acetylene welding, so care must be taken to ensure all oils and paint are removed from all surfaces of the parts to be welded.

Use a TIG welder with high-frequency starting to eliminate arc strikes. Do not weld where there is any breeze or draft; the welds should be allowed to cool slowly. Preheating is not necessary for tubing of less than 0.120-inch wall thickness; however, post-weld tempering (stress relieving) is still recommended to prevent the possible brittleness of the area surrounding the weld due to the untempered martensite formations caused by the rapid cooling of the weld inherent to the TIG process.

If you use 4130 filler rod, preheat the work before welding and heat treat afterward to avoid cracking. In a critical situation such as this, engineering should be done to determine preheat and post-weld heat treatment needed for the particular application.

Weld at a slower speed, make sufficiently large fillets, and make them flat or slightly convex, not concave. After the welding is complete, allow the weldment to cool to room temperature. Using an oxy-acetylene torch set to a neutral flame, heat the entire weldment evenly to 1,100 °F–1,200 °F; hold this temperature for about 45 minutes per inch of metal thickness. The temperature is generally accepted to be a dull red in ambient lighting. Note that for most tubing sections, the temperature needs to be held for only a minute or two. This process is found in most materials engineering handbooks written by The Materials Information Society (ASM) and other engineering sources. When working on a critical component, seek engineering help if there is any doubt.

## **TIG Welding Stainless Steel**

Stainless steels, or more precisely, corrosion-resisting steels, are a family of iron-based metals that contain chromium in amounts ranging from 10 percent to about 30 percent. Nickel is added to some of the stainless steels, which reduces the thermal conductivity and decreases the electrical conductivity. The chromium-nickel steels belong in the AISI 300 series of stainless steels. They are nonmagnetic and have austenitic microstructure. These steels are used extensively

in aircraft in which strength or resistance to corrosion at high temperature is required.

All of the austenitic stainless steels are weldable with most welding processes, with the exception of AISI 303, which contains high sulfur, and AISI 303Se, which contains selenium to improve its machinability.

The austenitic stainless steels are slightly more difficult to weld than mild-carbon steel. They have lower melting temperatures, and a lower coefficient of thermal conductivity, so welding current can be lower. This helps on thinner materials because these stainless steels have a higher coefficient of thermal expansion, requiring special precautions and procedures to be used to reduce warping and distortion. Any of the distortion-reducing techniques, such as skip welding or back-step welding, should be used. Fixtures and/or jigs should be used where possible. Tack welds should be applied twice as often as normal.

The selection of the filler metal alloy for welding the stainless steel is based on the composition of the base metal. Filler metal alloys for welding austenitic type stainless include AISI No. 309, 310, 316, 317, and 347. It is possible to weld several different stainless base metals with the same filler metal alloy. Follow the manufacturer's recommendations.

Clean the base metal just prior to welding to prevent the formation of oxides. Clean the surface and joint edges with a nonchlorinated solvent, and brush with a stainless steel wire brush to remove the oxides. Clean the filler material in the same manner.

To form a weld bead, move the torch along the joint at a steady speed using the forehand method. Dip the filler metal into the center of the weld puddle to ensure adequate shielding from the gas.

The base metal needs protection during the welding process by either an inert gas shield, or a backing flux, on both sides of the weld. Back purging uses a separate supply of shielding gas to purge the backside of the weld of any ambient air. Normally, this requires sealing off the tubular structures or using other various forms of shields and tapes to contain the shielding gas. A special flux may also be used on the inside of tubular structures in place of a back purge. This is especially advantageous with exhaust system repairs in which sealing off the entire system is time consuming. The flux is the same as is used for the oxy-acetylene welding process on stainless materials.

## TIG Welding Aluminum

TIG welding of aluminum uses similar techniques and filler materials as oxy-fuel welding. Consult with the particular welding machine manufacturer for recommendations on tungsten type and size, as well as basic machine settings for a particular weldment because this varies with specific machine types. Typically, the machine is set to an AC output waveform because it causes a cleaning action that breaks up surface oxides. Argon or helium shielding gas may be used, but argon is preferred because it uses less by volume than helium. Argon is a heavier gas than helium, providing better cover, and it provides a better cleaning action when welding aluminum.

Filler metal selection is the same as used with the oxy-fuel process; however, the use of a flux is not needed as the shielding gas prevents the formation of aluminum oxide on the surface of the weld pool, and the AC waveform breaks up any oxides already on the material. Cleaning of the base metal and filler follows the same guidelines as for oxy-fuel welding. When welding tanks of any kind, it is a good practice to back-purge the inside of the tank with a shielding gas. This promotes a sound weld with a smooth inner bead profile that can help lessen pinhole leaks and future fatigue failures.

Welding is done with similar torch and filler metal angles as in oxy-fuel welding. The tip on the tungsten is held a short distance ( $\frac{1}{16}$ – $\frac{1}{8}$ -inch) from the surface of the material, taking care not to ever let the molten pool contact the tungsten and contaminate it. Contamination of the tungsten must be dealt with by removal of the aluminum from the tungsten and re-grinding the tip to the factory recommended profile.

## TIG Welding Magnesium

Magnesium alloys can be welded successfully using the same type joints and preparation that are used for steel or aluminum. However, because of its high thermal conductivity and coefficient of thermal expansion, which combine to cause severe stresses, distortion, and cracking, extra precautions must be taken. Parts must be clamped in a fixture or jig. Smaller welding beads, faster welding speed, and the use of a lower melting point and lower shrinkage filler rods are recommended.

DC, both straight or reverse polarity, and AC, with superimposed high frequency for arc stabilization, are commonly used for welding magnesium. DC reverse polarity provides better cleaning action of the metal and is preferred for manual welding operations.

AC power sources should be equipped with a primary contactor operated by a control switch on the torch or a foot control for starting or stopping the arc. Otherwise, the arcing

that occurs while the electrode approaches or draws away from the work piece may result in burned spots on the work.

Argon is the most common used shielding gas for manual welding operations. Helium is the preferred gas for automated welding because it produces a more stable arc than argon and permits the use of slightly longer arc lengths. Zirconiated, thoriated, and pure tungsten electrodes are used for TIG welding magnesium alloys.

The welding technique for magnesium is similar to that used for other non-ferrous metals. The arc should be maintained at about  $\frac{5}{16}$ -inch. Tack welds should be used to maintain fit and prevent distortion. To prevent weld cracking, weld from the middle of a joint towards the end, and use starting and run off plates to start and end the weld. Minimize the number of stops during welding. After a stop, the weld should be restarted about  $\frac{1}{2}$ -inch from the end of the previous weld. When possible, make the weld in one uninterrupted pass.

## TIG Welding Titanium

The techniques for welding titanium are similar to those required for nickel-based alloys and stainless steels. To produce a satisfactory weld, emphasis is placed on the surface cleanliness and the use of inert gas to shield the weld area. A clean environment is one of the requirements to weld titanium.

TIG welding of titanium is performed using DC straight polarity. A water-cooled torch, equipped with a  $\frac{3}{4}$ -inch ceramic cup and a gas lens, is recommended. The gas lens provides a uniform, nonturbulent inert gas flow. Thoriated tungsten electrodes are recommended for TIG welding of titanium. The smallest diameter electrode that can carry the required current should be used. A remote contactor controlled by the operator should be employed to allow the arc to be broken without removing the torch from the cooling weld metal, allowing the shielding gas to cover the weld until the temperature drops.

Most titanium welding is performed in an open fabrication shop. Chamber welding is still in use on a limited basis, but field welding is common. A separate area should be set aside and isolated from any dirt producing operations, such as grinding or painting. Additionally, the welding area should be free of air drafts and the humidity should be controlled.

Molten titanium weld metal must be totally shielded from contamination by air. Molten titanium reacts readily with oxygen, nitrogen, and hydrogen; exposure to these elements in air or in surface contaminants during welding can adversely affect titanium weld properties and cause weld embrittlement. Argon is preferred for manual welding because of better



arc stability characteristics. Helium is used in automated welding and when heavier base metals or deeper penetration is required.

Care must be taken to ensure that the heat affected zones and the root side of the titanium welds are shielded until the weld metal temperature drops below 800 °F. This can be accomplished using shielding gas in three separate gas streams during welding.

1. The first shielding of the molten puddle and adjacent surfaces is provided by the flow of gas through the torch. Manufacturer recommendations should be followed for electrodes, tip grinding, cup size, and gas flow rates.
2. The secondary, or trailing, shield of gas protects the solidified weld metal and the heat affected zone until the temperature drops. Trailing shields are custom-made to fit a specific torch and a particular welding operation.
3. The third, or backup, flow is provided by a shielding device that can take many forms. On straight seam welds, it may be a grooved copper backing bar clamped behind the seam allowing the gas flow in the groove and serving as a heat sink. Irregular areas may be enclosed with aluminum tents taped to the backside of welds and purged with the inert gas.

Titanium weld joints are similar to those employed with other metals. Before welding, the weld joint surfaces must be cleaned and remain free of any contamination during the welding operation. Detergent cleaners and nonchlorinated cleaners, such as denatured isopropyl alcohol, may be used. The same requirements apply to the filler rod, it too must be cleaned and free of all contaminants. Welding gloves, especially the one holding the filler, must be contaminate free.

A good indication and measure of weld quality for titanium is the weld color. A bright silver weld indicates that the shielding is satisfactory and the heat affected zone and backup was properly purged until weld temperatures dropped. Straw-colored films indicate slight contamination, unlikely to affect mechanical properties; dark blue films or white powdery oxide on the weld would indicate a seriously deficient purge. A weld in that condition must be completely removed and rewelded.

## **Arc Welding Procedures, Techniques, and Welding Safety Equipment**

Arc welding, also referred to as stick welding, has been performed successfully on almost all types of metals. This section addresses the procedures as they may apply to fusion welding of steel plate and provides the basic steps

and procedures required to produce an acceptable arc weld. Additional instruction and information pertaining to arc welding of other metals can be obtained from training institutions and the various manufacturers of the welding equipment.

The first step in preparing to arc weld is to make certain that the necessary equipment is available and that the welding machine is properly connected and in good working order. Particular attention should be given to the ground connection, since a poor connection results in a fluctuating arc, that is difficult to control.

When using a shielded electrode, the bare end of the electrode should be clamped in its holder at a 90° angle to the jaws. (Some holders allow the electrode to be inserted at a 45° angle when needed for various welding positions.)

Before starting to weld, the following typical list of items should be checked:

- Is the proper personal safety equipment being used, including a welding helmet, welding gloves, protective clothing, and footwear; if not, in an adequately ventilated area, appropriate breathing equipment?
- Has the ground connection been properly made to the work piece and is it making a good connection?
- Has the proper type and size electrode been selected for the job?
- Is the electrode properly secured in the holder?
- Does the polarity of the machine coincide with that of the electrode?
- Is the machine in good working order and is it adjusted to provide the necessary current for the job?

The welding arc is established by touching the base metal plate with the electrode and immediately withdrawing it a short distance. At the instant the electrode touches the plate, a rush of current flows through the point of contact. As the electrode is withdrawn, an electric arc is formed, melting a spot on the plate and at the end of the electrode.

Correctly striking an arc takes practice. The main difficulty in confronting a beginner in striking the arc is sticking the electrode to the work. If the electrode is not withdrawn promptly upon contact with the metal, the high amperage flows through the electrode causing it to stick or freeze to the plate and practically short circuits the welding machine. A quick roll of the wrist, either right or left, usually breaks the electrode loose from the work piece. If that does not work, quickly unclamp the holder from the electrode, and turn off the machine. A small chisel and hammer frees the

electrode from the metal so it can be regripped in the holder. The welding machine can then be turned back on.

There are two essentially similar methods of striking the arc. One is the touch or tapping method. When using this method, the electrode should be held in a vertical position and lowered until it is an inch or so above the point where the arc is to be struck. Then, the electrode is lightly tapped on the work piece and immediately lifted to form an arc approximately  $\frac{1}{4}$ -inch in length. [Figure 5-29]

The second (and usually easier to master) is a scratch or sweeping method. To strike the arc by the scratch method, the electrode is held just above the plate at an angle of  $20^{\circ}$ – $25^{\circ}$ . The arc should be struck by sweeping the electrode with a wrist motion and lightly scratching the plate. The electrode is then lifted immediately to form an arc. [Figure 5-30]

Either method takes some practice, but with time and experience, it becomes easy. The key is to raise the electrode quickly, but only about  $\frac{1}{4}$ -inch from the base or the arc is lost. If it is raised too slowly, the electrode sticks to the plate.

To form a uniform bead, the electrode must be moved along the plate at a constant speed in addition to the downward

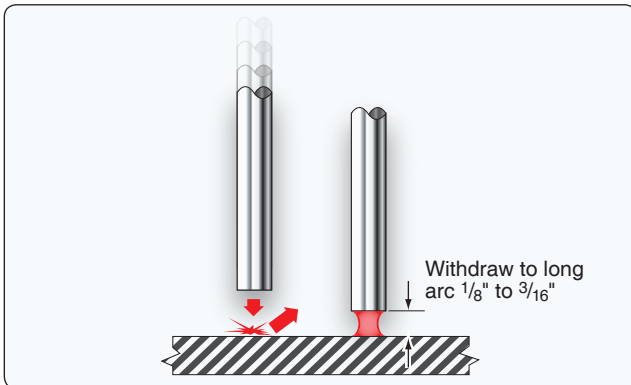

Figure 5-29. Touch method of starting an arc.

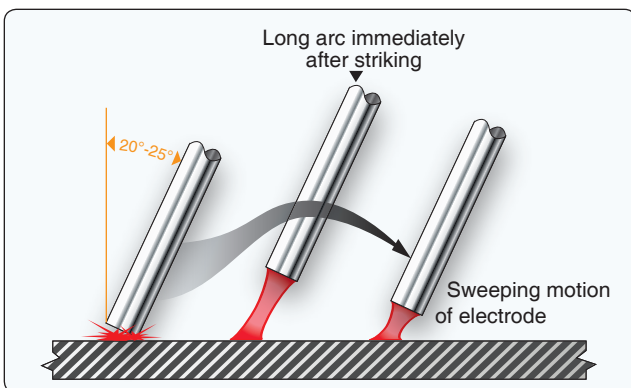

Figure 5-30. Scratch/sweeping method of starting the arc.

feed of the electrode. If the rate of advance is too slow, a wide overlapping bead forms with no fusion at the edges. If the rate is too fast, the bead is too narrow and has little or no fusion at the plate.

The proper length of the arc cannot be judged by looking at it. Instead, depend on the sound that the short arc makes. This is a sharp cracking sound, and it should be heard during the time the arc is being moved down to and along the surface of the plate.

A good weld bead on a flat plate should have the following characteristics:

- Little or no splatter on the surface of the plate.
- An arc crater in the bead of approximately  $\frac{1}{16}$ -inch when the arc has been broken.
- The bead should be built up slightly, without metal overlap at the top surface.
- The bead should have a good penetration of approximately  $\frac{1}{16}$ -inch into the base metal.

Figure 5-31 provides examples of operator's technique and welding machine settings.

When advancing the electrode, it should be held at an angle of about  $20^{\circ}$  to  $25^{\circ}$  in the direction of travel moving away from the finished bead. [Figure 5-32]

If the arc is broken during the welding of a bead and the electrode is removed quickly, a crater is formed at the point where the arc ends. This shows the depth of penetration or fusion that the weld is getting. The crater is formed by the pressure of the gases from the electrode tip forcing the weld metal toward the edges of the crater. If the electrode is removed slowly, the crater is filled.

If you need to restart an arc of an interrupted bead, start just ahead of the crater of the previous weld bead, as shown in position 1, Figure 5-33. Then, the electrode should be returned to the back edge of the crater (step 2). From this point, the weld may be continued by welding right through the crater and down the line of weld as originally planned (step 3).

Once a bead has been formed, every particle of slag must be removed from the area of the crater before restarting the arc. This is accomplished with a pick hammer and wire brush and prevents the slag from becoming trapped in the weld.

### Multiple Pass Welding

Groove and fillet welds in heavy metals often require the deposit of a number of beads to complete a weld. It is important that the beads be deposited in a predetermined sequence to produce the soundest welds with the best

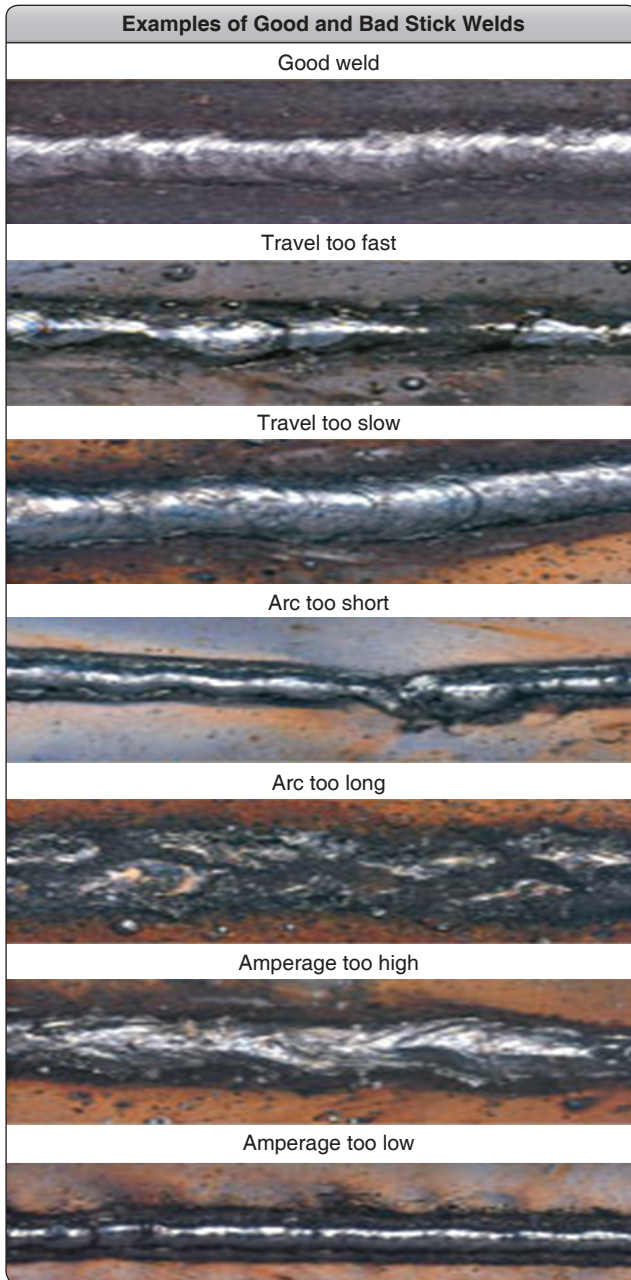

Figure 5-31. Examples of good and bad stick welds.

proportions. The number of beads is determined by the thickness of the metal being welded.

Plates from 1/8-inch to 1/4-inch can be welded in one pass, but they should be tacked at intervals to keep them aligned. Any weld on a plate thicker than 1/4-inch should have the edges beveled and multiple passes.

The sequence of the bead deposits is determined by the kind of joint and the position of the metal. All slag must be removed from each bead before another bead is deposited.



Figure 5-32. Angle of electrode.

Typical multiple-pass groove welding of butt joints is shown in Figure 5-34.

### Techniques of Position Welding

Each time the position of a welded joint or the type of joint is changed, it may be necessary to change any one or a combination of the following:

- Current value
- Electrode
- Polarity
- Arc length
- Welding technique

Current values are determined by the electrode size, as well as the welding position. Electrode size is governed by the thickness of the metal and the joint preparation. The electrode type is determined by the welding position. Manufacturers specify the polarity to be used with each electrode. Arc length

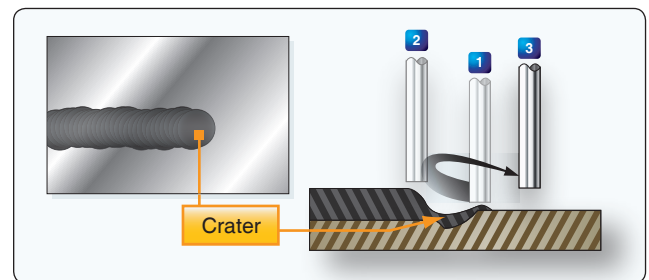

Figure 5-33. Restarting the arc.

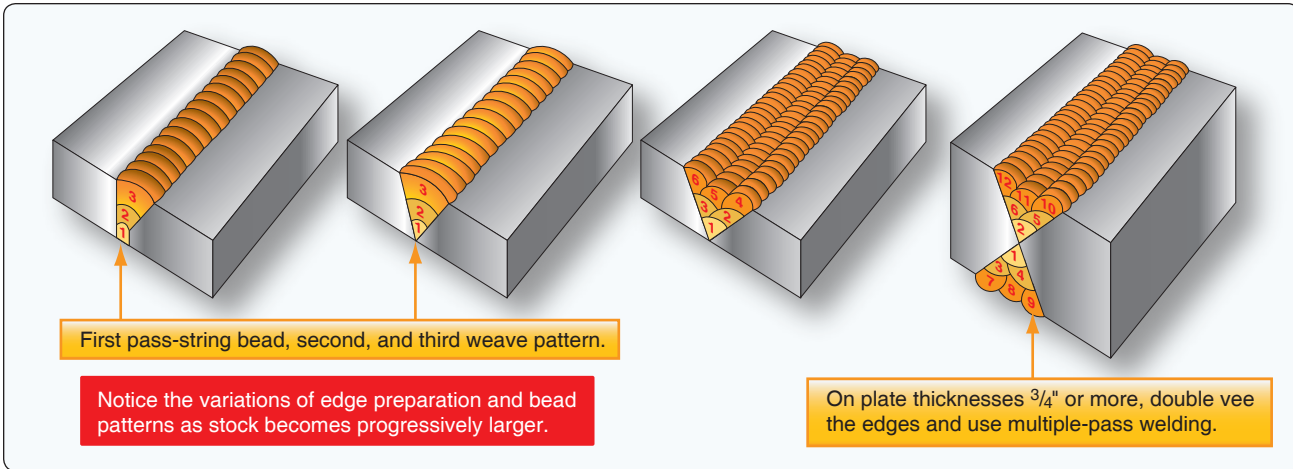

Figure 5-34. Multiple-pass groove welding of butt joints.

is controlled by a combination of the electrode size, welding position, and welding current.

Since it is impractical to cite every possible variation occasioned by different welding conditions, only the information necessary for the commonly used positions and welds is discussed here.

### Flat Position Welding

There are four types of welds commonly used in flat position welding: bead, groove, fillet, and lap joint. Each type is discussed separately in the following paragraphs.

#### Bead Weld

The bead weld utilizes the same technique that is used when depositing a bead on a flat metal surface. [Figure 5-35] The only difference is that the deposited bead is at the butt joint of two steel plates, fusing them together. Square butt joints may be welded in one or multiple passes. If the thickness of the metal is such that complete fusion cannot be obtained by welding from one side, the joint must be welded from both sides. Most joints should first be tack-welded to ensure alignment and reduce warping.

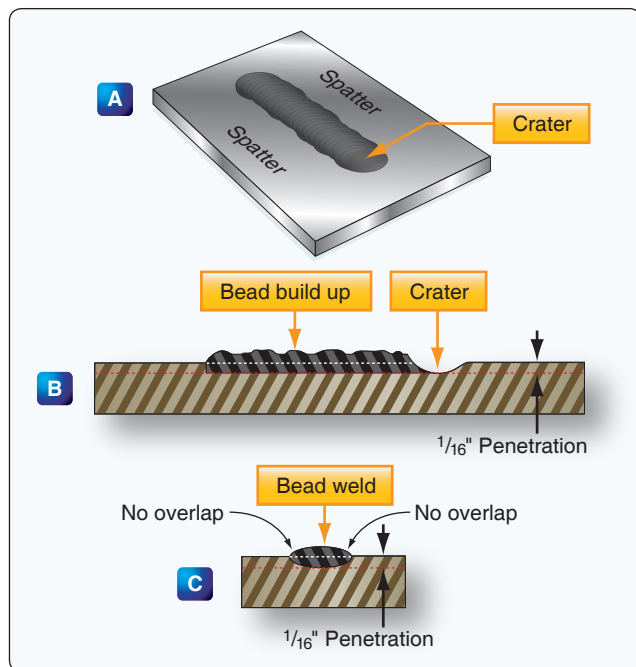

Figure 5-35. Proper bead weld.

#### Groove Weld

Groove welding may be performed on a butt joint or an outside corner joint. Groove welds are made on butt joints where the metal to be welded is 1/4-inch or more in thickness. The butt joint can be prepared using either a single or double groove depending on the thickness of the plate. The number of passes required to complete a weld is determined by the thickness of the metal being welded and the size of the electrode being used.

Any groove weld made in more than one pass must have the slag, spatter, and oxide carefully removed from all

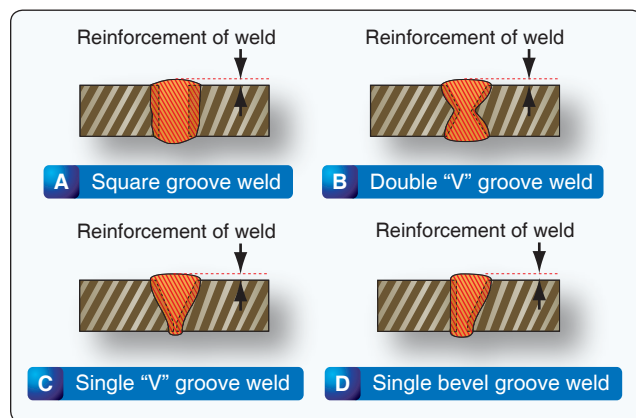

Figure 5-36. Groove welds on butt joints in the flat position.

previous weld deposits before welding over them. Some of the common types of groove welds performed on butt joints in the flat position are shown in *Figure 5-36*.

### **Fillet Weld**

Fillet welds are used to make tee and lap joints. The electrode should be held at an angle of  $45^\circ$  to the plate surface. The electrode should be tilted at an angle of about  $15^\circ$  in the direction of welding. Thin plates should be welded with little or no weaving motion of the electrode and the weld is made in one pass. Fillet welding of thicker plates may require two or more passes using a semicircular weaving motion of the electrode. [*Figure 5-37*]

### **Lap Joint Weld**

The procedure for making fillet weld in a lap joint is similar to that used in the tee joint. The electrode is held at about a  $30^\circ$  angle to the vertical and tilted to an angle of about  $15^\circ$  in the direction of welding when joining plates of the same thickness. [*Figure 5-38*]

### **Vertical Position Welding**

Vertical positioning welding includes any weld applied to a surface inclined more than  $45^\circ$  from the horizontal. Welding in the vertical position is more difficult than welding in the

flat position because of the force of gravity. The molten metal has the tendency to run down. To control the flow of molten metal, the voltage and current adjustments of the welding machine must be correct.

The current setting, or amperage, is less for welding in the vertical position than for welding in the flat position for similar size electrodes. Additionally, the current used for welding upward should be set slightly higher than the current used for welding downward on the same work piece. When welding up, hold the electrode  $90^\circ$  to the vertical, and weld moving the bead upward. Focus on welding the sides of the joint and the middle takes care of itself. In welding downward, with the hand below the arc and the electrode tilted about  $15^\circ$  upward, the weld should move downward.

### **Overhead Position Welding**

Overhead position welding is one of the most difficult in welding since a very short arc must be constantly maintained to control the molten metal. The force of gravity tends to cause the molten metal to drop down or sag from the plate, so it is important that protective clothing and head gear be worn at all times when performing overhead welding.

For bead welds in an overhead position, the electrode should be held at an angle of  $90^\circ$  to the base metal. In some cases where it is desirable to observe the arc and the crater of the weld, the electrode may be held at an angle of  $15^\circ$  in the direction of welding.

When making fillet welds on overhead tee or lap joints, a short arc should be held, and there should be no weaving of the electrode. The arc motion should be controlled to secure good penetration to the root of the weld and good fusion to the plates. If the molten metal becomes too fluid and tends to sag, the electrode should be whipped away quickly from the center ahead of the weld to lengthen the arc and allow the metal to solidify. The electrode should then be returned immediately to the crater of the weld and the welding continued.

Anyone learning or engaged in arc welding should always have a good view of the weld puddle. Otherwise there is no way to ensure that the welding is in the joint and keeping the arc on the leading edge of the puddle. For the best view, the welder should keep their head off to the side and out of the fumes so they can see the puddle.

### **Expansion and Contraction of Metals**

The expansion and contraction of metal is a factor taken into consideration during the design and manufacturing of all aircraft. It is equally important to recognize and allow for the dimensional changes and metal stress that may occur during any welding process.

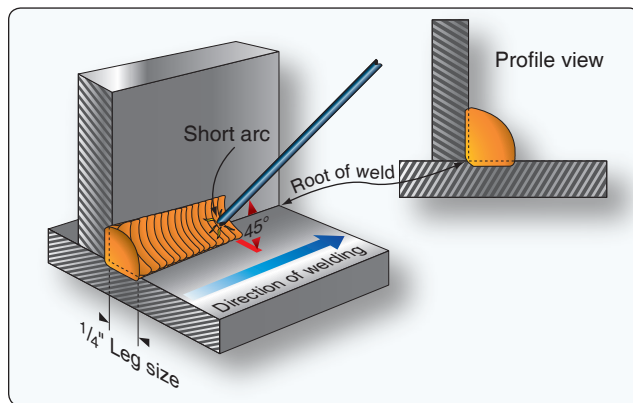

**Figure 5-37.** Tee joint fillet weld.

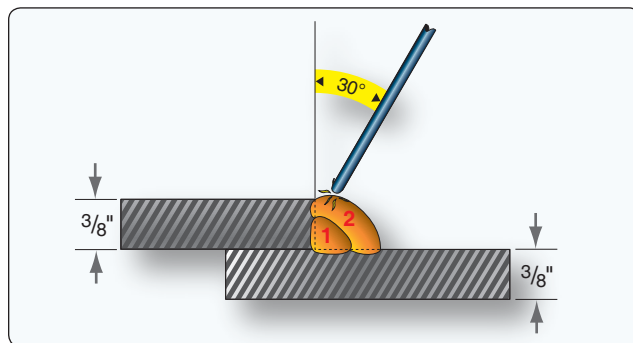

**Figure 5-38.** Typical lap joint fillet weld.

Heat causes metals to expand; cooling causes them to contract. Therefore, uneven heating causes uneven expansion, and uneven cooling causes uneven contraction. Under such conditions, stresses are set up within the metal. These forces must be relieved, and unless precautions are taken, warping or buckling of the metal takes place. Likewise, on cooling, if nothing is done to take up the stress set up by the contraction forces, further warping may result; or if the metal is too heavy to permit this change in shape, the stresses remain within the metal itself.

The coefficient of linear expansion of a metal is the amount in inches that a one inch piece of metal expands when its temperature is raised 1 °F. The amount that a piece of metal expands when heat is applied is found by multiplying the coefficient of linear expansion by the temperature rise and multiplying that product by the length of the metal in inches.

Expansion and contraction have a tendency to buckle and warp thin sheet metal 1/8-inch or thinner. This is the result of having a large surface area that spreads heat rapidly and dissipates it soon after the source of heat is removed. The most effective method of alleviating this situation is to remove the heat from the metal near the weld, preventing it from spreading across the whole surface area. This can be done by placing heavy pieces of metal, known as chill bars, on either side of the weld; to absorb the heat and prevent it from spreading. Copper is most often used for chill bars because of its ability to absorb heat readily. Welding fixtures sometimes use this same principle to remove heat from the base metal. Expansion can also be controlled by tack welding at intervals along the joint.

The effect of welding a seam longer than 10 or 12 inches is to draw the seam together as the weld progresses. If the edges of the seam are placed in contact with each other throughout their length before welding starts, the far ends of the seam actually overlap before the weld is completed. This tendency can be overcome by setting the pieces to be welded with the seam spaced correctly at one end and increasing the space at the opposite end. [Figure 5-39]

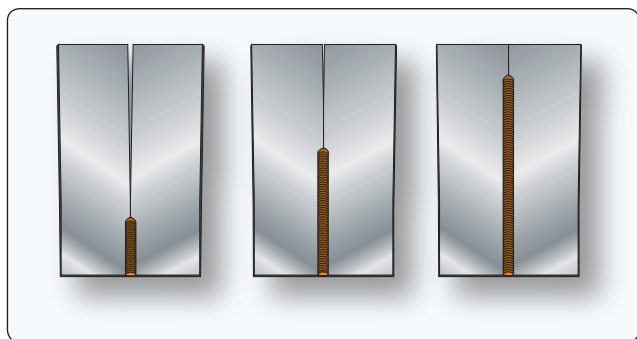

**Figure 5-39.** Allowance for a straight butt weld when joining steel sheets.

The amount of space allowed depends on the type of material, the thickness of the material, the welding process being used, and the shape and size of the pieces to be welded. Instruction and/or welding experience dictates the space needed to produce a stress-free joint.

The weld is started at the correctly spaced end and proceeds toward the end that has the increased gap. As the seam is welded, the space closes and should provide the correct gap at the point of welding. Sheet metal under 1/16-inch can be handled by flanging the edges, tack welding at intervals, and then by welding between the tacks.

There are fewer tendencies for plate stock over 1/8-inch to warp and buckle when welded because the greater thickness limits the heat to a narrow area and dissipates it before it travels far on the plate.

Preheating the metal before welding is another method of controlling expansion and contraction. Preheating is especially important when welding tubular structures and castings. Great stress can be set up in tubular welds by contraction. When welding two members of a tee joint, one tube tends to draw up because of the uneven contraction. If the metal is preheated before the welding operation begins, contraction still takes place in the weld, but the accompanying contraction in the rest of the structure is at almost the same rate, and internal stress is reduced.

## Welded Joints Using Oxy-Acetylene Torch

Figure 5-40 shows various types of basic joints.

### Butt Joints

A butt joint is made by placing two pieces of material edge to edge, without overlap, and then welding. A plain butt joint is

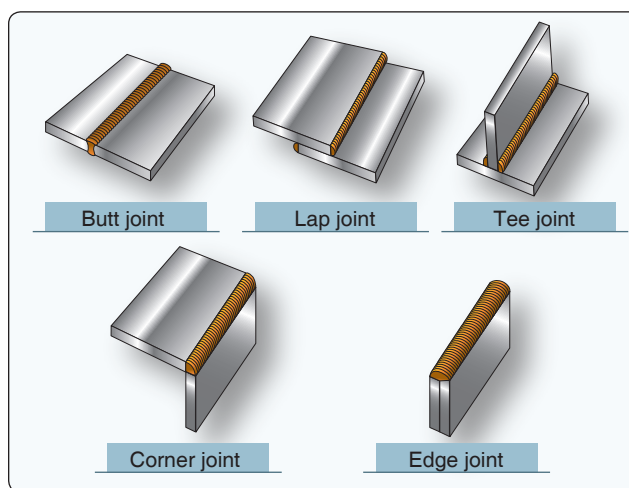

**Figure 5-40.** Basic joints.

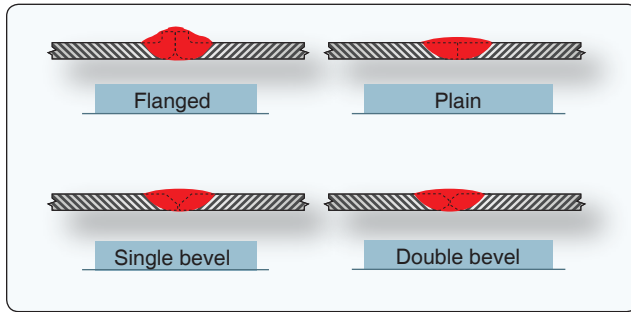

Figure 5-41. Types of butt joints.

used for metals from  $\frac{1}{16}$ -inch to  $\frac{1}{8}$ -inch in thickness. A filler rod is used when making this joint to obtain a strong weld.

The flanged butt joint can be used in welding thin sheets,  $\frac{1}{16}$ -inch or less. The edges are prepared for welding by turning up a flange equal to the thickness of the metal. This type of joint is usually made without the use of a filler rod.

If the metal is thicker than  $\frac{1}{8}$ -inch, it may be necessary to bevel the edges so that the heat from the torch can completely penetrate the metal. These bevels may be either single or double-bevel type or single or double-V type. A filler rod is used to add strength and reinforcement to the weld. [Figure 5-41]

Repair of cracks by welding may be considered just another type of butt joint. The crack should be stop drilled at either end and then welded like a plain butt joint using filler rod. In most cases, the welding of the crack does not constitute a complete repair and some form of reinforcement is still required, as described in following sections.

### Tee Joints

A tee joint is formed when the edge or end of one piece is welded to the surface of another. [Figure 5-42] These joints are quite common in aircraft construction, particularly in tubular structures. The plain tee joint is suitable for most thicknesses of metal used in aircraft, but heavier thicknesses require the vertical member to be either single or double-beveled to permit the heat to penetrate deeply enough. The

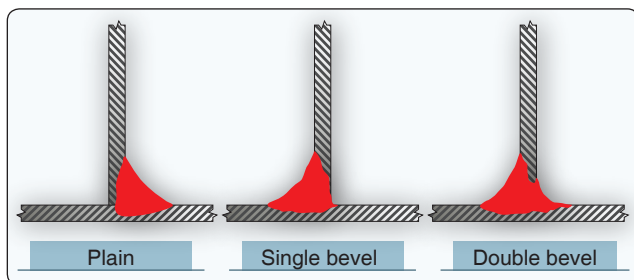

Figure 5-42. Types of tee joints showing filler penetration.

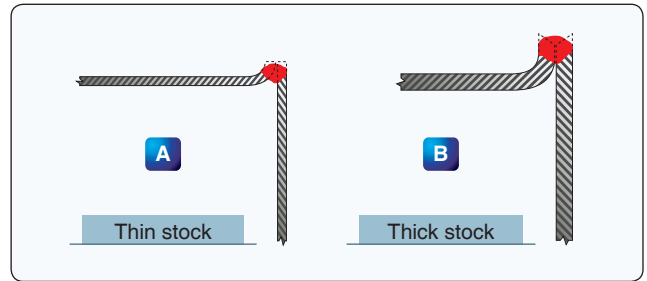

Figure 5-43. Edge joints.

dark areas in Figure 5-42 show the depth of heat penetration and fusion required. It is a good practice to leave a gap between the parts, about equal to the metal thickness to aid full penetration of the weld. This is common when welding from only one side with tubing clusters. Tight fitment of the parts prior to welding does not provide for a proper weldment unless full penetration is secured, and this is much more difficult with a gapless fitment.

### Edge Joints

An edge joint is used when two pieces of sheet metal must be fastened together and load stresses are not important. Edge joints are usually made by bending the edges of one or both parts upward, placing the two ends parallel to each other, and welding along the outside of the seam formed by the two joined edges. The joint shown in Figure 5-43A requires no filler rod since the edges can be melted down to fill the seam. The joint shown in Figure 5-43B, being thicker material, must be beveled for heat penetration; filler rod is added for reinforcement.

### Corner Joints

A corner joint is made when two pieces of metal are brought together so that their edges form a corner of a box or enclosure. [Figure 5-44] The corner joint shown in Figure 5-44A requires no filler rod, since the edges fuse to make the weld. It is used where the load stress is not important. The type shown in Figure 5-44B is used on heavier

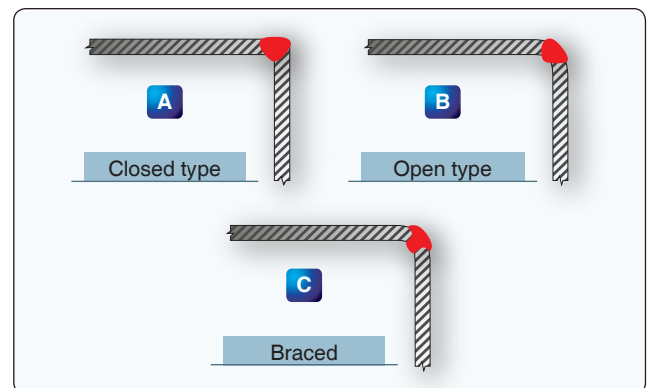

Figure 5-44. Corner joints.

metals, and filler rod is added for roundness and strength. If a higher stress is to be placed on the corner, the inside is reinforced with another weld bead. [Figure 5-44C]

### Lap Joints

The lap joint is seldom used in aircraft structures when welding with oxy-acetylene, but is commonly used and joined by spot welding. The single lap joint has very little resistance to bending, and cannot withstand the shearing stress to which the weld may be subjected under tension or compression loads. The double lap joint offers more strength, but requires twice the amount of welding required on the simpler, more efficient butt weld. [Figure 5-45]

## Repair of Steel Tubing Aircraft Structure by Welding

### Dents at a Cluster Weld

Dents at a cluster weld can be repaired by welding a formed steel patch plate over the dented area and surrounding tubes. Remove any existing finish on the damaged area and thoroughly clean prior to welding.

To prepare the patch plate, cut a section from a steel sheet of the same material and thickness as the heaviest tube damaged.

Fashion the reinforcement plate so that the fingers extend over the tubes a minimum of  $1\frac{1}{2}$  times the respective tube diameter. The plate may be cut and formed prior to welding or cut and tack welded to the cluster, then heated and formed around the joint to produce a snug smooth contour. Apply sufficient heat to the plate while forming so there is a gap of no more than  $\frac{1}{16}$ -inch from the contour of the joint to the plate.

In this operation, avoid unnecessary heating and exercise care to prevent damage at the point of the angle formed by any two adjacent fingers of the plate. After the plate is formed and tack welded to the joint, weld all the plate edges to the cluster joint. [Figure 5-46]

### Dents Between Clusters

A damaged tubular section can be repaired using welded split sleeve reinforcement. The damaged member should be carefully straightened and should be stop drilled at the ends of any cracks with a No. 40 drill bit.

Select a length of steel tube of the same material and at least the same wall thickness having an inside diameter approximately equal to the outside diameter of the damaged tube.

Diagonally cut the selected piece at a  $30^\circ$  angle on both ends so the minimum distance of the sleeve from the edge of the crack or dent is not less than  $1\frac{1}{2}$  times the diameter of the damaged tube. Then, cut through the entire length of the sleeve and separate the half sections as shown in Figure 5-47. Clamp the two sleeve sections in the proper position on the

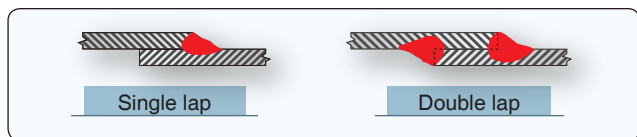

Figure 5-45. Single and double lap joints.

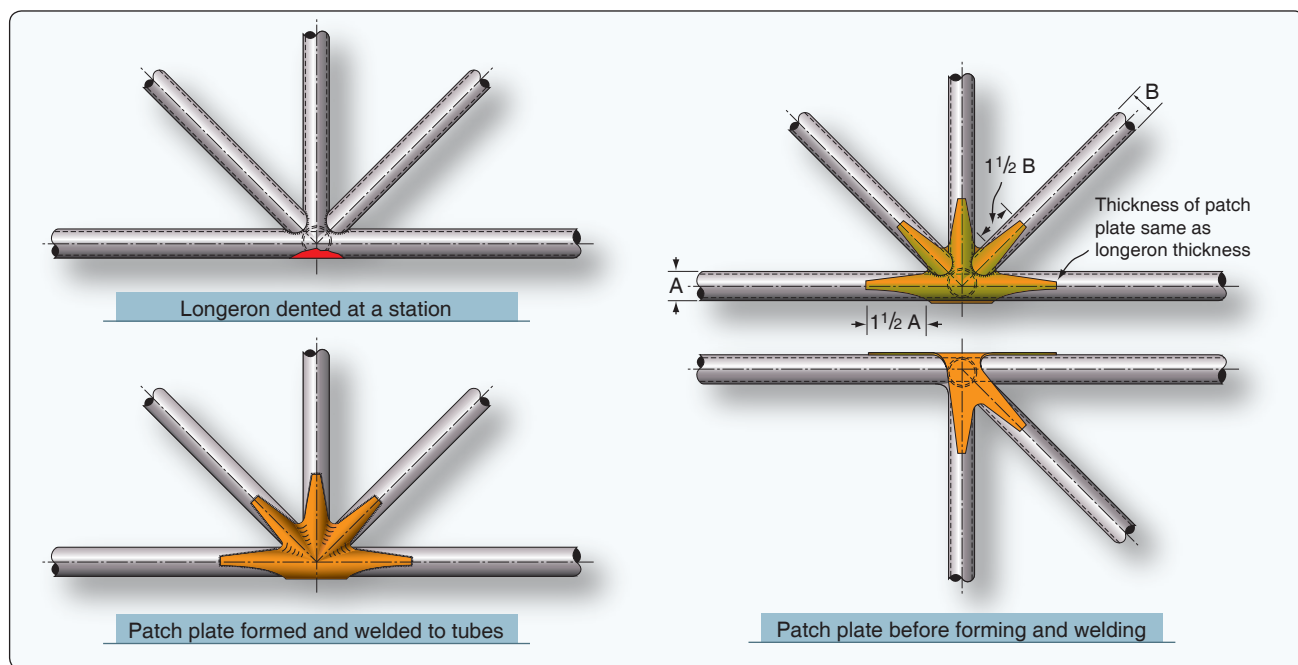

Figure 5-46. Repair of tubing dented at a cluster.



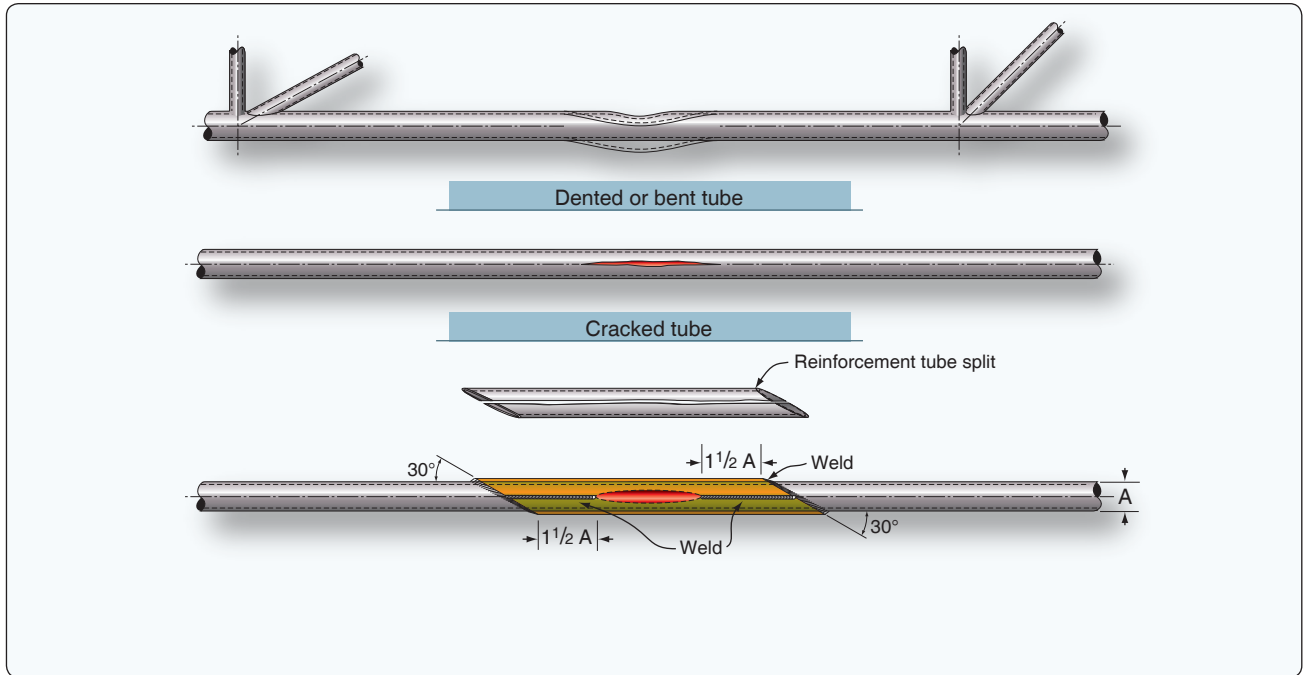

Figure 5-47. Repair using welded sleeve.

damaged area of the tube. Weld the reinforcement sleeve along the length of the two sides, and weld both ends of the sleeve to the damaged tube.

#### Tube Splicing with Inside Sleeve Reinforcement

If a partial replacement of the tube is necessary, do an inner sleeve splice, especially where you want a smooth tube surface.

Make a diagonal cut to remove the damaged section of the tube, and remove the burrs from the inner and outer cut edges with a file or similar means. Diagonally cut a replacement steel tube of the same material, diameter, and wall thickness to match the length of the removed section of the damaged tube. The replacement tube should allow a 1/8-inch gap for welding at each end to the stubs of the original tube.

Select a length of steel tubing of the same material and at least the same wall thickness with an outside diameter equal to the inside diameter of the damaged tube. From this inner sleeve tube material, cut two sections of tubing, each of such a length that the ends of the inner sleeve is a minimum distance of 1 1/2 times the tube diameter from the nearest end of the diagonal cut. Tack the outer and inner replacement tubes using rosette welds. Weld the inner sleeve to the tube stubs through the 1/8-inch gap forming a weld bead over the gap and joining with the new replacement section. [Figure 5-48]

#### Tube Splicing with Outer Split Sleeve Reinforcement

If partial replacement of a damaged tube is necessary, make the outer sleeve splice using a replacement tube of the same diameter and material. [Figures 5-49 and 5-50]

To perform the outer sleeve repair, remove the damaged section of the tube, utilizing a 90° cut at either end. Cut a replacement steel tube of the same material, diameter, and at least the same wall thickness to match the length of the removed portion of the damaged tube. The replacement tube must bear against the stubs of the original tube with a tolerance of ±1/4-inch. The material selected for the outer sleeve must be of the same material and at least the same wall thickness as the original tube. The clearance between the inside diameter of the sleeve and the outside

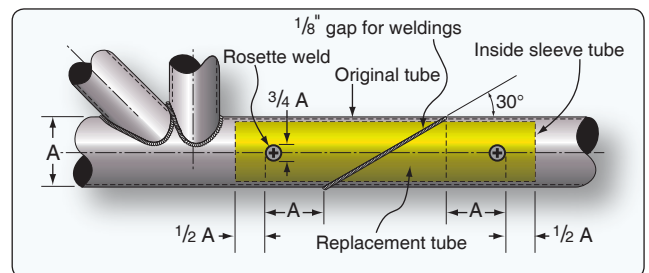

Figure 5-48. Splicing with inner sleeve method.

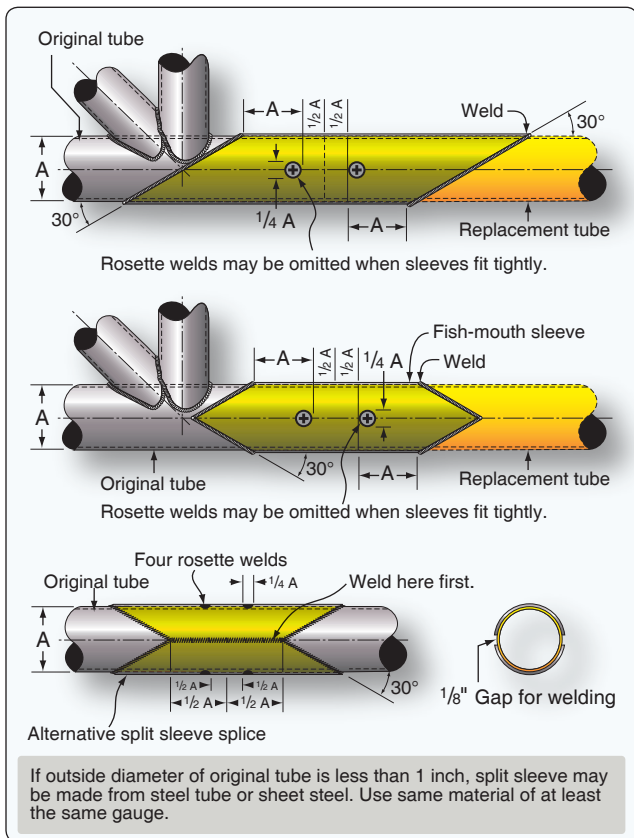

Figure 5-49. Splicing by the outer sleeve method.

diameter of the original tube may not exceed  $\frac{1}{16}$ -inch. From this outer sleeve tube material, either cut diagonally or fishmouth two sections of tubing, each of such a length that the nearest end of the outer sleeve is a minimum distance of  $1\frac{1}{2}$  tube diameters from the end of the cut on the original tube. Use the fish mouth sleeve wherever possible. Remove

all burrs from the edges of the replacement tube, sleeves, and the original tube stubs.

Slip the two sleeves over the replacement tube, align the replacement tube with the original tube stubs, and slip the sleeves over the center of each joint. Adjust the sleeves to the area to provide maximum reinforcement.

Tack weld the two sleeves to the replacement tube in two places before welding ends. Apply a uniform weld around both ends of one of the reinforcement sleeves and allow the weld to cool. Then, weld around both ends of the remaining reinforcement tube. Allow one sleeve weld to cool before welding the remaining tube to prevent undue warping.

### Landing Gear Repairs

Some components of a landing gear may be repaired by welding while others, when damaged, may require replacement. Representative types of repairable and nonrepairable landing gear assemblies are shown in Figure 5-51.

The landing gear types shown in A, B, and C of this figure are repairable axle assemblies. They are formed from steel tubing and may be repaired by any of the methods described in this chapter or in FAA Advisory Circular (AC) 43.13-1, Acceptable Methods, Techniques, and Practices—Aircraft Inspection and Repair. However, it must be determined if the assemblies were heat treated. Assemblies originally heat treated must be reheated after a welding repair.

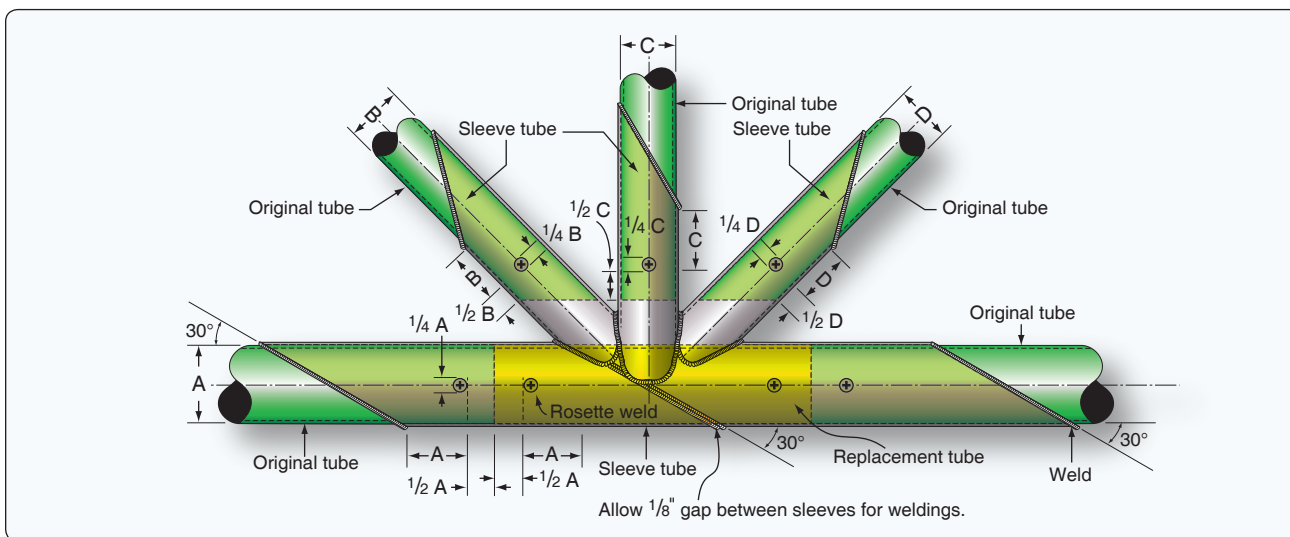

Figure 5-50. Tube replacement at a cluster by outer sleeve method.



**Figure 5-51.** Representative types of repairable and nonrepairable landing gear assemblies.

The landing gear assembly type D is generally nonrepairable for the following reasons:

1. The lower axle stub is usually made from a highly heat-treated nickel alloy steel and machined to close tolerances. It should be replaced when damaged.
2. During manufacture, the upper oleo section of the assembly is heat treated and machined to close tolerances to assure proper functioning of the shock absorber. These parts would be distorted by any welding repair and should be replaced if damaged to ensure the part was airworthy.

The spring-steel leaf, shown as type E, is a component of a standard main landing gear on many light aircraft. The spring-steel part is, in general, nonrepairable, should not be welded on, and should be replaced when it is excessively sprung or otherwise damaged.

Streamline tubing, used for some light aircraft landing gear, may be repaired using a round insert tube of the same material and having a wall thickness of one gauge thicker than the original streamline tube and inserting and welding as shown in *Figure 5-52*.

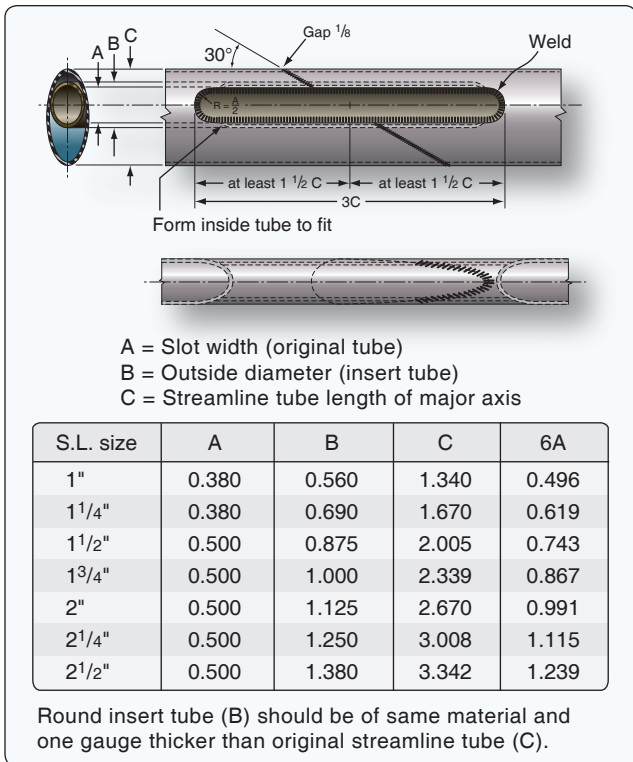

Figure 5-52. Streamline landing gear repair using round tube.

The streamline landing gear tube may also be repaired by inserting a tube of the same streamline original tubing and welding. This can be accomplished by cutting off the trailing edge of the insert and fitting it into the original tube. Once fitted, remove the insert, weld the trailing edge back together, and reinsert into the original tube. Use the figures and weld as indicated in Figure 5-53.

**Engine Mount Repairs**

All welding on an engine mount should be performed by an experienced welder and be of the highest quality, since vibration tends to accentuate any minor defect.

The preferred method to repair an engine mount member is by using a larger diameter replacement tube telescoped over the stub of the original member using fish-mouth and rosette welds. 30° scarf welds are also acceptable in place of the fish-mouth welds.

One of the most important aspects to keep in mind when repairing an engine mount is that the alignment of the structure must be maintained. This can be accomplished by attaching to a fixture designed for that purpose, or bolting the mount to an engine and/or airframe before welding.

All cracked welds should be ground out and only high-grade filler rod of the appropriate material should be used.

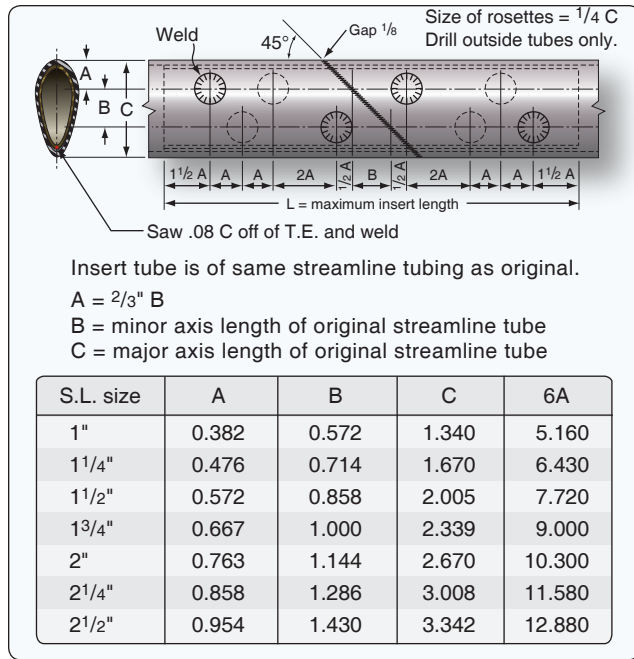

Figure 5-53. Streamline tube splice using split insert.

If all members of the mount are out of alignment, the mount should be replaced with one supplied by the manufacturer or with one built to conform to the manufacturer’s drawings and specifications.

Minor damage, such as a crack adjacent to an engine attachment lug, can be repaired by rewelding the ring and extending a gusset or a mounting lug past the damaged area. Engine mount rings that are extensively damaged must not be repaired unless the method of repair is specifically approved by FAA Engineering, a Designated Engineering Representative (DAR), or the repair is accomplished in accordance with FAA-approved instructions.

If the manufacturer stress relieved the engine mount after welding, the engine mount should again be stress relieved after weld repairs are made.

**Rosette Welding**

Rosette welds are used on many of the type repairs that were previously discussed. They are holes, typically one-fourth the diameter of the original tube, drilled in the outer splice and welded around the circumference for attachment to the inner replacement tube or original tube structure.