



150 SERIES

1969 THRU 1976

SERVICE MANUAL

CHANGE
NOTICE

**LATEST CHANGED PAGES SUPERSEDE
THE SAME PAGES OF PREVIOUS DATE**

Insert changed pages into basic
publication. Destroy superseded pages.

1 JULY 1972

LIST OF EFFECTIVE PAGES

NOTE: The portion of the text affected by the changes is indicated by a vertical line in the outer margins of the page. Changes to illustrations are indicated by miniature pointing hands.

Dates of issue for original and changed pages are:

Original 0 1 July 1972
 Change 1 1 June 1973
 Change 2 1 July 1974
 Change 3 15 June 1975

TOTAL NUMBER OF PAGES IN THIS PUBLICATION IS 346, CONSISTING OF THE FOLLOWING:

Page No.	Change No.	Page No.	Change No.	Page No.	Change No.
*Title	3	*5-17	3	14-2 thru 14-3	1
*A	3	5-18	1	14-4	0
i	1	*5-19 thru 5-25	3	15-1	1
*ii	3	5-26 thru 5-27	0	*15-2	3
iii	0	*5-28	3	*15-2A	3
iv Blank	0	6-1 thru 6-2	0	*15-2B Blank	3
1-1	0	*6-3	3	*15-3	3
*1-2 thru 1-4	3	6-4	0	15-4 thru 15-5	0
1-5	2	*6-5	3	*15-6	3
1-6 Blank	2	6-6 thru 6-7	0	15-7 thru 15-8	0
2-1	0	6-8 Blank	0	15-9	2
2-2	2	7-1 thru 7-9	1	15-10 thru 15-12	0
2-2A	2	7-10 thru 7-11	2	*15-13	3
2-2B Blank	2	7-12 Blank	2	15-14	2
2-3	1	*8-1	3	15-15 thru 15-17	1
2-4	2	8-2	0	15-18 thru 15-20	0
2-5	1	*8-3 thru 8-6	3	15-21 thru 15-22	2
*2-6 thru 2-7	3	*9-1 thru 9-4	3	*16-1	3
2-8	0	*9-4A	3	16-2	1
*2-9 thru 2-11	3	*9-4B Blank	3	16-3	2
2-12	1	*9-5 thru 9-6	3	16-4 thru 16-5	1
*2-13 thru 2-14	3	10-1	2	16-6	0
2-15	2	*10-2	3	*16-7	3
*2-16 thru 2-17	3	*10-2A	3	16-8 thru 16-11	0
2-18 thru 2-19	1	*10-2B Blank	3	*16-12 thru 16-14	3
2-20	2	10-3	0	16-15	1
2-21 thru 2-24	1	10-4	2	*16-16	3
*2-25	3	10-5 thru 10-6	1	16-16A	1
*2-26 Blank	3	*11-1 thru 11-3	3	16-16B Blank	1
*3-1	3	11-4 thru 11-10	0	16-17 thru 16-19	1
3-2	0	*11-11 thru 11-12	3	16-19A thru 16-19B	1
*3-3	3	11-13 thru 11-16	0	16-20 thru 16-22	1
3-4 thru 3-5	2	11-17	1	16-23	2
*3-6 thru 3-15	3	11-18 thru 11-21	0	*16-24	3
*3-16 Blank	3	11-22	1	16-25 thru 16-26	0
4-1	0	11-22A	1	*16-26A	3
*4-2	3	11-22B Blank	1	*16-26B Blank	3
4-3	2	11-23	1	16-27	2
*4-4 thru 4-6	3	11-24 thru 11-25	0	16-28 thru 16-30	0
4-7	2	11-26 Blank	0	*16-31 thru 16-36	3
4-8 Blank	2	*12-1	3	*18-1 thru 18-2	3
*5-1 thru 5-3	3	12-2	0	18-3 thru 18-4	0
5-4	0	12-3	2	18-5 thru 18-6	2
*5-5 thru 5-6	3	12-4	1	*18-7	3
5-7	1	12-5 thru 12-7	2	18-8 thru 18-11	0
5-8	2	12-8	1	18-12	1
*5-8A thru 5-8B	3	12-9	0	18-13 thru 18-33	0
*5-9 thru 5-11	3	12-10 Blank	0	18-34 Blank	0
5-12	1	*13-1	3	*19-1 thru 19-2	3
*5-13	3	13-2	1	*20-1 thru 20-61	3
5-14	1	*13-3 thru 13-4	3	*20-62 Blank	3
5-15 thru 5-16	0	14-1	0		

Upon receipt of the second and subsequent changes to this book, personnel responsible for maintaining this publication in current status should ascertain that all previous changes have been received and incorporated.

* The asterisk indicates pages changed, added or deleted by the current change.

TABLE OF CONTENTS

SECTION		Page
1	GENERAL DESCRIPTION	1-1
2	GROUND HANDLING, SERVICING, LUBRICATION AND INSPECTION	2-1
3	FUSELAGE	3-1
4	WINGS AND EMPENNAGE	4-1
5	LANDING GEAR AND BRAKES	5-1
6	AILERON CONTROL SYSTEM	6-1
7	WING FLAP CONTROL SYSTEM	7-1
8	ELEVATOR CONTROL SYSTEM	8-1
9	ELEVATOR TRIM TAB CONTROL SYSTEM	9-1
10	RUDDER CONTROL SYSTEM	10-1
11	ENGINE	11-1
12	FUEL SYSTEM	12-1
13	PROPELLER	13-1
14	UTILITY SYSTEMS	14-1
15	INSTRUMENTS AND INSTRUMENT SYSTEMS	15-1
16	ELECTRICAL SYSTEMS	16-1
17	ELECTRONIC SYSTEMS (DELETED) (See page iii)	
18	STRUCTURAL REPAIR	18-1
19	PAINTING	19-1
20	WIRING DIAGRAMS	20-1

CROSS REFERENCE LISTING OF POPULAR
NAME VS. MODEL NUMBERS AND SERIALS

All aircraft, regardless of manufacturer, are certificated under model number designations. However, popular names are often used for marketing purposes. To provide a consistent method of referring to the various aircraft, model numbers will be used in this publication unless names are required to differentiate between versions of the same basic model. The following table provides a cross reference listing of popular name vs. model numbers.

POPULAR NAME	MODEL YEAR	MODEL	SERIALS	
			BEGINNING	ENDING
150 STANDARD 150 TRAINER, or 150 COMMUTER	1969	150J	15069309	15071128
	1970	150K	15071129	15072003
	1971	150L	15072004	15072628
	1972	150L	15072629	15073661
	1973	150L	15073662	15074850
	1974	150L	15074851	15075781
150 STANDARD 150 COMMUTER 150 COMMUTER II	1975	150M	15075782	15077005
150 COMMUTER 150 COMMUTER II	1976	150M	15077006	
REIMS 150 REIMS/CESSNA F150	1969	F150J	F15000390	F15000529
	1970	F150K	F15000530	F15000658
	1971	F150L	F15000659	F15000738
	1972	F150L	F15000739	F15000863
	1973	F150L	F15000864	F15001013
	1974	F150L	F15001014	F15001143
REIMS/CESSNA F150 REIMS/CESSNA F150 COM- MUTER	1975	F150M	F15001144	F15001248
	1976	F150M	F15001249	
150 AEROBAT	1970	A150K	A1500001	A1500226
	1971	A150L	A1500227	A1500276
	1972	A150L	A1500277	A1500339
	1973	A150L	A1500340	A1500430
	1974	A150L	A1500431	A1500523
	1975	A150M	A1500524	A1500609
	1976	A150M	A1500610	
REIMS/CESSNA F150 AEROBAT	1970	FA150K	FA1500001	FA1500081
	1971	FA150L	FA1500082	FA1500120
	1972	FA150L	FA1500121	FA1500166
	1973	FA150L	FA1500167	FA1500211
	1974	FA150L	FA1500212	FA1500261
	1975	FA150M	FA1500262	FA1500281
	1976	FA150M	FA1500282	

FOREWORD

This manual contains factory-recommended procedures and instructions for ground handling, servicing, and maintaining Cessna Model 150-Series aircraft. This includes the Models 150, Reims 150, Reims/Cessna F150, 150 Aerobat, and Reims/Cessna F150 Aerobat. The Reims versions of the Model 150 is identical to the Model 150 except that it is powered by a O-200-A Rolls Royce engine. Besides serving as a reference for the experienced mechanic, this book also covers step-by-step procedures for the less experienced man. This manual should be kept in a handy place for ready reference. If properly used, it will better enable the mechanic to maintain Cessna 150-Series aircraft and thereby establish a reputation for reliable service.

The information in this manual is based on data available at the time of publication, and is supplemented and kept current by service letters and service news letters published by Cessna Aircraft Company. These are sent to all Cessna Dealers so that they have the latest authoritative recommendations for servicing Cessna aircraft. Therefore, it is recommended that Cessna owners utilize the knowledge and experience of the factory-trained Dealer Service Organization.

In addition to the information in this Service Manual, a group of vendor publications is available from the Cessna Service Parts Center, which describe complete disassembly, overhaul, and parts breakdown of some of the various vendor equipment items. A listing of the available publications is issued periodically in service letters.

Information for Nav-O-Matic Autopilots, Electronic Communications, and Navigation Equipment are not included in this manual. These manuals are available from the Cessna Service Parts Center.

This page intentionally left blank.

SECTION 1
GENERAL DESCRIPTION

TABLE OF CONTENTS	Page		
GENERAL DESCRIPTION	1-1	Description	1-1
Model 150 and F150-Series	1-1	Aircraft Specifications	1-1
Description	1-1	Stations	1-1
Model A150 and FA150-Series	1-1	Torque Values	1-1

1-1. GENERAL DESCRIPTION.

1-2. MODEL 150 AND F150-SERIES.

1-3. DESCRIPTION. Cessna Model 150 and F150-Series aircraft, described in this manual, are high-wing monoplanes of all-metal, semimonocoque construction. These aircraft are equipped with a fixed tricycle landing gear. Through 1970 Models, they are equipped with flat spring-steel main landing gear struts and a steerable nose gear. Beginning with 1971 Models, these aircraft are equipped with tubular spring-steel main gear struts and a steerable nose gear. The steerable nose gear is equipped with an air/hydraulic fluid shock strut. Two-place seating is standard, and a double-width, fold-up auxiliary rear seat may be installed as optional equipment. Each Model 150 and F150-Series aircraft is equipped with a four-cylinder, horizontally opposed, air-cooled Continental or Rolls Royce engine, driving an all-metal, fixed-pitch propeller. These aircraft feature a "wrap around" rear window and a swept-back fin and rudder.

1-4. MODEL A150 and FA150-SERIES.

1-5. DESCRIPTION. Aerobatic Model A150 and FA150-Series aircraft are a modification of the currently produced Model 150. Structure has been

"beefed-up" in some areas in order to meet requirements of the Acrobatic Category, FAR Part 23. In addition to the "beef-up", quick-release cabin doors, two-strap shoulder harnesses, and aerobatic paint design are standard. Only momentary inverted flight is approved, therefore no inverted system is offered. Removable seat and back cushions are provided to allow occupants to use either a seat-pack or back-pack type parachute during aerobatic maneuvers.

1-6. AIRCRAFT SPECIFICATIONS. Leading particulars of these aircraft, with dimensions based on gross weight, are given in figure 1-1. If these dimensions are used for constructing a hangar or computing clearances, remember that such factors as nose gear strut inflation, tire pressures, tire sizes, and load distribution may result in some dimensions that are considerably different from those listed.

1-7. STATIONS. Station diagrams are shown in figures 1-2 and 1-3 to assist in locating equipment when a written description is inadequate or impractical.

1-8. TORQUE VALUES. A chart of recommended nut torque values is shown in figure 1-4. These torque values are recommended for all installation procedures contained in this manual, except where other values are stipulated. They are not to be used for checking tightness of installed parts during service.

GROSS WEIGHT	1600 lb	
FUEL CAPACITY		
Standard Wing (Total)	26 gal.	
Standard Wing (Usable)	22.5 gal.	
Long-Range Wing (Total)	38 gal.	
Long-Range Wing (Usable)	35 gal.	
OIL CAPACITY		
Without External Filter	6 qt	
With External Filter	7 qt	
ENGINE MODEL (Refer to Section 11 for Engine Data)	CONTINENTAL O-200 Series	
PROPELLER (Fixed Pitch)	69" McCauley	
MAIN WHEEL TIRES	6.00 x 6, 4-Ply Rating	
Pressure	21 psi	
NOSE WHEEL TIRE (Standard)	5.00 x 5, 4-Ply Rating	
Pressure	30 psi	
NOSE WHEEL TIRE (Optional)	15 x 6.00 x 6, 4-Ply Rating	
Pressure	35 psi	
NOSE GEAR STRUT PRESSURE (Strut Extended)	20 psi	
WHEEL ALIGNMENT (Flat Spring Struts)		
Camber	4° to 6°	
Toe-In	0" to .06"	
WHEEL ALIGNMENT (Tubular Gear)		
Camber	3° to 5°	TUBULAR GEAR
Toe-In00" to +.16"	NON-ADJUSTABLE
AILERON TRAVEL		
Up	20°, +2° -0°	
Down	14°, +2° -0°	
WING FLAP TRAVEL	0° to 40° ±2°	
RUDDER TRAVEL (Measured parallel to water line)		
Right	20° 30', +0° -2°	
Left	20° 30', +0° -2°	
RUDDER TRAVEL (Measured perpendicular to hinge line)		
Right	23°, +0° -2°	
Left	23°, +0° -2°	
ELEVATOR TRAVEL		
Up (Thru 1974)	25° ±1°	
Up (Beginning with 1975)	23°, +1° -0°	
Down	15° ±1°	
ELEVATOR TRIM TAB TRAVEL		
Up	10° ±1°	
Down	20° ±1°	
PRINCIPAL DIMENSIONS		
Wing Span (Conventional Wing Tip)	32' 8-1/2"	
Wing Span (Conical-Camber Wing Tip)	33' 2"	(Add 2" for optional
Length (With Large Spinner) (Thru 1970)	23' 9"	strobe lights)
Length (With Small Spinner) (Thru 1970)	23' 0"	
Length (With Large Spinner) (Beginning with 1971)	23' 8-1/2"	
Length (With Small Spinner) (Beginning with 1971)	23' 0"	
Fin Height (Maximum with Nose Gear Depressed and		
Flashing Beacon Installed on Fin (Thru 1974)	8' 0"	
Fin Height (Maximum with Nose Gear Depressed and		
Flashing Beacon Installed on Fin) (Beginning with 1975).	8' 6"	
Track Width (Thru 1970)	6' 6-1/2"	
Track Width (Beginning with 1971)	7' 7-1/4"	
Tail Span.	10' 0"	
BATTERY LOCATION	Firewall	

Figure 1-1. Aircraft Specifications

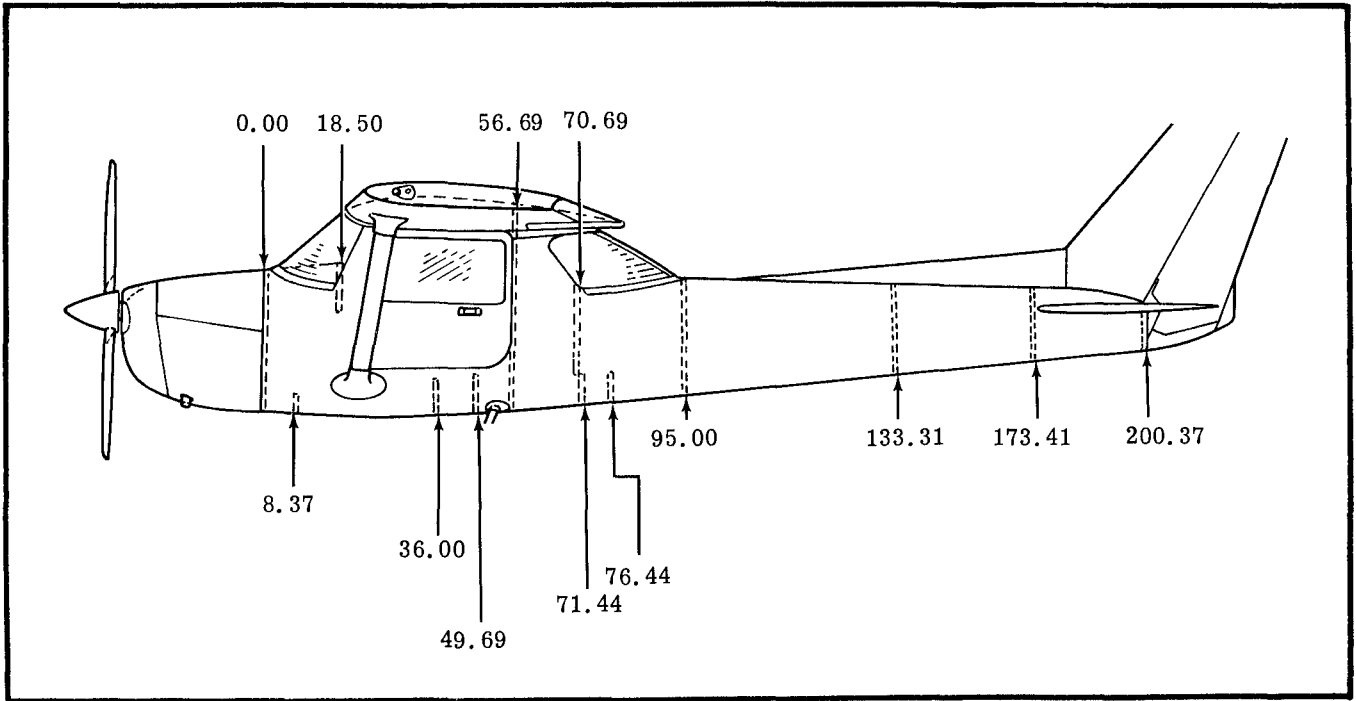

Figure 1-2. Fuselage Stations

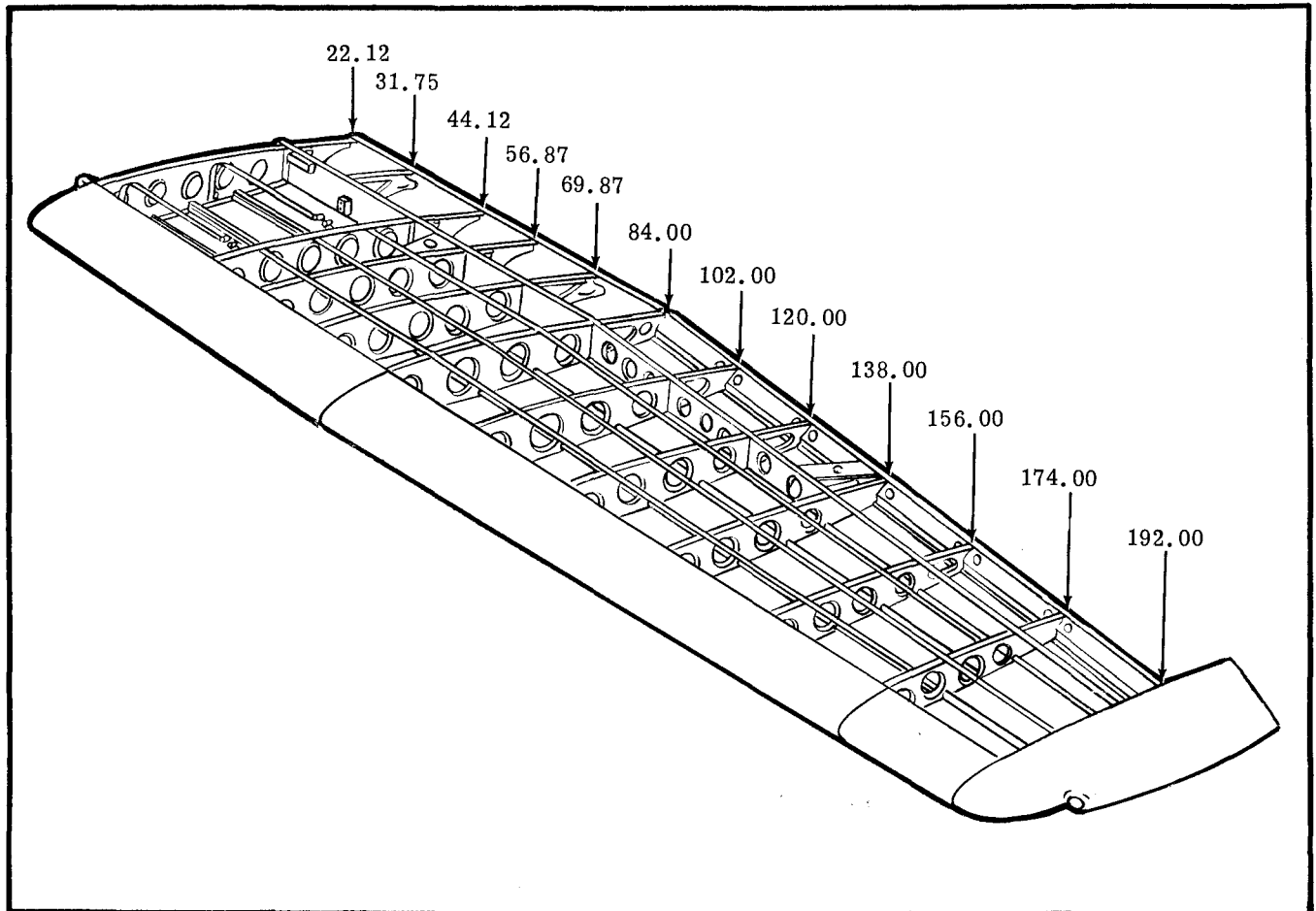

Figure 1-3. Wing Stations

RECOMMENDED NUT TORQUES

THE TORQUE VALUES STATED ARE POUND-INCHES, RELATED ONLY TO STEEL NUTS ON OIL-FREE CADMIUM PLATED THREADS.

FINE THREAD SERIES

TAP SIZE	TENSION		SHEAR	
	TORQUE		TORQUE	
	STD (NOTE 1)	ALT (NOTE 2)	STD (NOTE 3)	ALT (NOTE 2)
8-36	12-15		7-9	
10-32	20-25	20-28	12-15	12-19
1/4-28	50-70	50-75	30-40	30-48
5/16-24	100-140	100-150	60-85	60-106
3/8-24	160-190	160-260	95-110	95-170
7/16-20	450-500	450-560	270-300	270-390
1/2-20	480-690	480-730	290-410	290-500
9/16-18	800-1000	800-1070	480-600	480-750
5/8-18	1100-1300	1100-1600	660-780	660-1060
3/4-16	2300-2500	2300-3350	1300-1500	1300-2200
7/8-14	2500-3000	2500-4650	1500-1800	1500-2900
1-14	3700-5500	3700-6650	2200-3300	2200-4400
1-1/8-12	5000-7000	5000-10000	3000-4200	3000-6300
1-1/4-12	9000-11000	9000-16700	5400-6600	5400-10000

COARSE THREAD SERIES

	(NOTE 4)		(NOTE 5)	
8-32	12-15		7-9	
10-24	20-25		12-15	
1/4-20	40-50		25-30	
5/16-18	80-90		48-55	
3/8-16	160-185		95-100	
7/16-14	235-255		140-155	
1/2-13	400-480		240-290	
9/16-12	500-700		300-420	
5/8-11	700-900		420-540	
3/4-10	1150-1600		700-950	
7/8-9	2200-3000		1300-1800	
1-8	3700-5000		2200-3000	
1-1/8-8	5500-6500		3300-4000	
1-1/4-8	6500-8000		4000-5000	

NOTES

1. Covers AN310, AN315, AN345, AN363, MS20365, MS21042, MS21044, MS21045 and MS21046.
2. When using AN310 or AN320 castellated nuts where alignment between the bolt and cotter pin slots is not reached using normal torque values, use alternate torque values or replace the nut.
3. Covers AN316, AN320, MS20364 and MS21245.
4. Covers AN363, MS20365, MS21042, MS21043, MS21044, MS21045 and MS21046.
5. Covers AN340.

CAUTION

DO NOT REUSE SELF-LOCKING NUTS.

The above values are recommended for all installation procedures contained in this manual, except where other values are stipulated. They are not to be used for checking tightness of installed parts during service.

Figure 1-4. Torque Values

RECOMMENDED NUT TORQUES

THE TORQUE VALUES STATED ARE POUND-INCHES, RELATED ONLY TO STEEL NUTS ON OIL-FREE CADMIUM PLATED THREADS.				
FINE THREAD SERIES				
TAP SIZE	TENSION		SHEAR	
	TORQUE		TORQUE	
	STD (NOTE 1)	ALT (NOTE 2)	STD (NOTE 3)	ALT (NOTE 2)
8-36	12-15		7-9	
10-32	20-25	20-28	12-15	12-19
1/4-28	50-70	50-75	30-40	30-48
5/16-24	100-140	100-150	60-85	60-106
3/8-24	160-190	160-260	95-110	95-170
7/16-20	450-500	450-560	270-300	270-390
1/2-20	480-690	480-730	290-410	290-500
9/16-18	800-1000	800-1070	480-600	480-750
5/8-18	1100-1300	1100-1600	660-780	660-1060
3/4-16	2300-2500	2300-3350	1300-1500	1300-2200
7/8-14	2500-3000	2500-4650	1500-1800	1500-2900
1-14	3700-5500	3700-6650	2200-3300	2200-4400
1-1/8-12	5000-7000	5000-10000	3000-4200	3000-6300
1-1/4-12	9000-11000	9000-16700	5400-6600	5400-10000
COARSE THREAD SERIES				
	(NOTE 4)		(NOTE 5)	
8-32	12-15		7-9	
10-24	20-25		12-15	
1/4-20	40-50		25-30	
5/16-18	80-90		48-55	
3/8-16	160-185		95-100	
7/16-14	235-255		140-155	
1/2-13	400-480		240-290	
9/16-12	500-700		300-420	
5/8-11	700-900		420-540	
3/4-10	1150-1600		700-950	
7/8-9	2200-3000		1300-1800	
1-8	3700-5000		2200-3000	
1-1/8-8	5500-6500		3300-4000	
1-1/4-8	6500-8000		4000-5000	
NOTES				
<ol style="list-style-type: none"> 1. Covers AN310, AN315, AN345, AN363, MS20365, MS21042, MS21044, MS21045 and MS21046. 2. When using AN310 or AN320 castellated nuts where alignment between the bolt and cotter pin slots is not reached using normal torque values, use alternate torque values or replace the nut. 3. Covers AN316, AN320, MS20364 and MS21245. 4. Covers AN363, MS20365, MS21042, MS21043, MS21044, MS21045 and MS21046. 5. Covers AN340. 				
CAUTION				
DO NOT REUSE SELF-LOCKING NUTS.				
The above values are recommended for all installation procedures contained in this manual, except where other values are stipulated. They are not to be used for checking tightness of installed parts during service.				

Figure 1-4. Torque Values

This page intentionally left blank.

SECTION 2

GROUND HANDLING, SERVICING, LUBRICATION AND INSPECTION

TABLE OF CONTENTS

	Page		
GROUND HANDLING	2-1	Vacuum System Filter	2-8
Towing	2-1	Battery	2-8
Hoisting	2-3	Tires	2-8
Jacking	2-3	Nose Gear Shock Strut	2-9
Leveling	2-3	Nose Gear Shimmy Dampener	2-9
Parking	2-3	Hydraulic Brake Systems	2-9
Tie-Down	2-3	CLEANING	2-9
Flyable Storage	2-3	Windshield and Windows	2-9
Returning Aircraft to Service	2-3	Plastic Trim	2-9
Temporary Storage	2-3	Painted Surfaces	2-9
Inspection During Storage	2-4	Aluminum Surfaces	2-13
Returning Aircraft to Service	2-4	Engine Compartment	2-13
Indefinite Storage	2-4	Upholstery and Interior	2-13
Inspection During Storage	2-5	Propeller	2-13
Returning Aircraft to Service	2-5	Wheels	2-13
SERVICING	2-6	LUBRICATION	2-13
Fuel	2-6	Tachometer Drive Shaft	2-13
Fuel Drains	2-6	Wheel Bearings	2-13
Carburetor Drain Plug Inspection	2-6	Nose Gear Torque Links	2-13
Engine Oil	2-6	Wing Flap Actuator	2-13
Engine Induction Air Filter	2-7	INSPECTION	2-18

2-1. GROUND HANDLING.

2-2. TOWING. Moving the aircraft by hand is accomplished by using the wing struts and landing gear struts as push points. A tow bar attached to the nose gear should be used for steering and maneuvering the aircraft on the ground. When no tow bar is available, press down at the horizontal stabilizer front spar adjacent to the fuselage to raise the nose wheel off the ground. With the nose wheel clear of the ground, the aircraft can be turned by pivoting it about the main wheels.

CAUTION

When towing the aircraft, never turn the nose wheel more than 30 degrees either side of center or the nose gear will be damaged. Do not push on control surfaces or outboard empennage surfaces. When pushing on the tailcone, always apply pressure at a bulkhead to avoid buckling the skin.

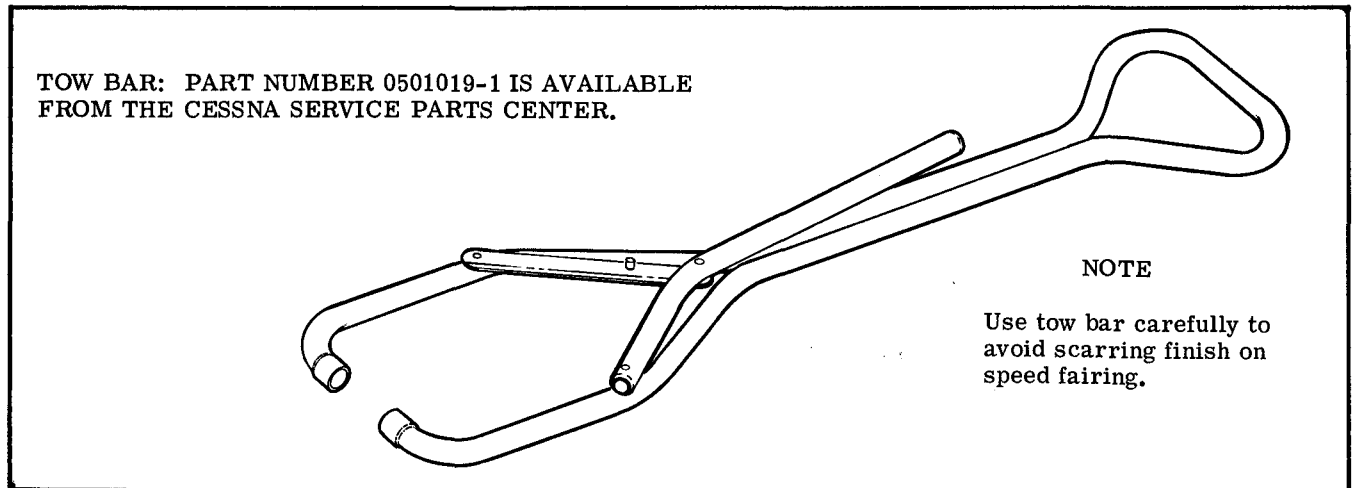
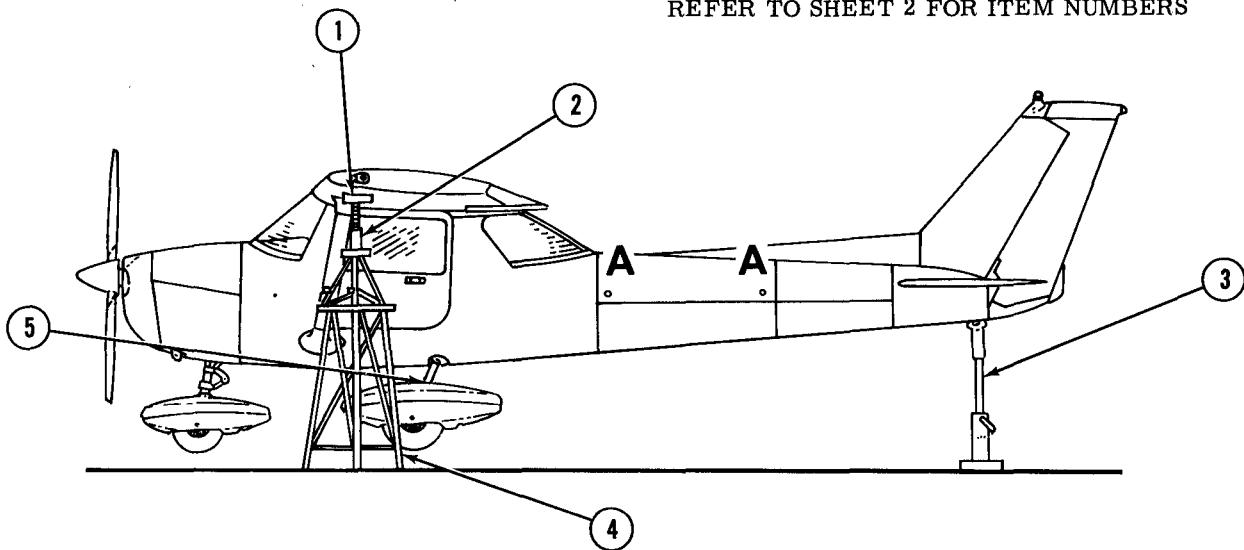

Figure 2-1. Tow Bar

REFER TO SHEET 2 FOR ITEM NUMBERS



NOTE

Corresponding points on both upper door sills may be used to level the aircraft laterally.

Prior to 1971 Models, reference points for leveling the aircraft longitudinally are the top of the tailcone between rear window and vertical fin.

Beginning with 1971 Models, reference points for longitudinal leveling of aircraft are two screws on left side of tailcone at zero waterline. These are indicated in illustration by **A**

(Also refer to paragraph 2-5)

REFER TO SHEET 2 FOR ITEM NUMBERS

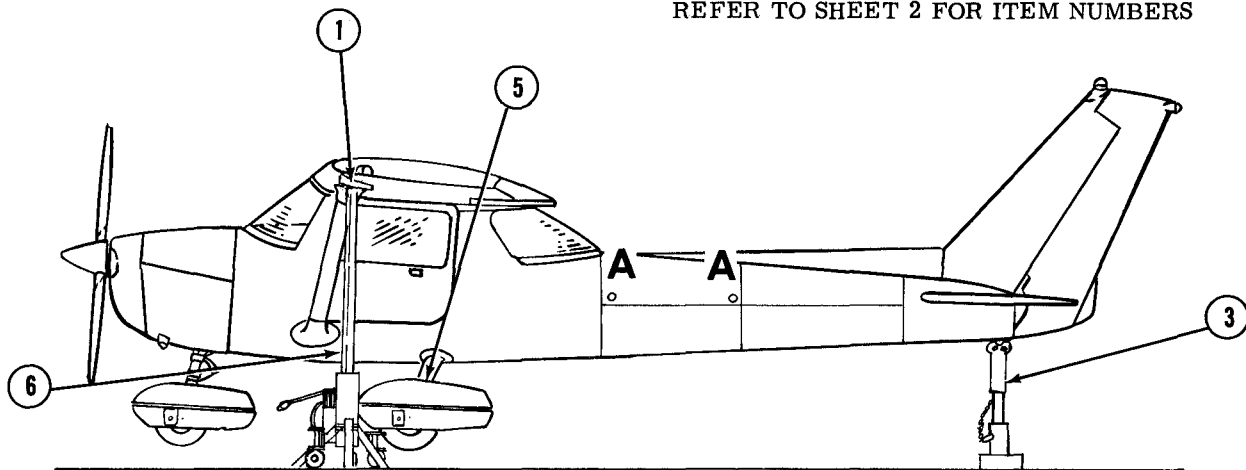

Figure 2-2. Jacking and Leveling (Sheet 1 of 2)

JACKING INFORMATION

ITEM NUMBER	TYPE AND NUMBER	REMARKS
①	Block (Jack point not available)	1x4x4 padded with 1/4" rubber
②	Jack	Any short jack of capable capacity
③	Universal tail stand	Any tail stand of capable capacity
④	Cessna #SE-576 (41-1/2" high)	Universal jack stand (FOR USE WITH ITEM 2)
⑤	Cessna #10004-98 Cessna #0441215-1 Built-in jack pad	Jack point * (SEE CAUTION) Jack point # (SEE NOTE 5) Part of step bracket †
⑥	#2-170 Basic jack #2-70 Slide tube (Use with item 1)	Closed height: 69 1/2 inches; extended height: 92" (Insert slide tube extension into basic jack)

1. Wing jacks are placed under front spar of wing just outboard of wing strut, and must extend far enough to raise wheels off ground, and must be of adequate strength.
2. Attach a suitable stand to the tie-down ring. Be sure tail stand weighs enough to keep tail down and under all conditions that it is strong enough to support any weight that might be placed on it (place shot bags or sand bags on tail stand. In addition, the base of adjustable tail stand is to be filled with concrete for additional weight as a safety factor.
3. Operate jacks evenly until desired height is reached.

CAUTION

When using universal jack point (10004-98), flexibility of the gear strut will cause the main wheel to slide inboard as the wheel is raised, tilting the jack. The jack must be lowered for a second operation. Jacking both wheels simultaneously with universal jack points is not recommended. Universal jack point may be used to raise only one main wheel. DO NOT USE brake casting as a jack point.

4. Items (4), (5) and (6) are available from the Cessna Service Parts Center.
5. On tubular gear aircraft, the only fairing requiring removal is the fuselage-to-tube gear fairing. Jack pad is inserted on tube in area between fuselage and upper end of tube fairing, then jack aircraft as required.

* Thru Serials 15072003, A15000276, F15000658 and FA1500081.

Serials 15073004 thru 15073284, A15000277 thru A15000324, F15000659 thru F15000833 and FA1500082 thru FA15000166.

† Beginning with Serials 15073285, A15000325, F15000834 and FA15000167.

This page intentionally left blank.

2-3. **HOISTING.** The aircraft may be lifted with a hoist of two-ton capacity by using hoisting rings, which are optional equipment, or by means of suitable slings. The front sling should be hooked to each upper engine mount at the firewall, and the aft sling should be positioned around the fuselage at the first bulkhead forward of the leading edge of the stabilizer. If the optional hoisting rings are used, a minimum cable length of 60 inches for each cable is required to prevent bending of the eyebolt-type hoisting rings. If desired, a spreader jig may be fabricated to apply vertical force to the eyebolts.

2-4. **JACKING.** Refer to figure 2-2 for jacking procedures.

2-5. **LEVELING.** Corresponding points on both upper door sills may be used to level the aircraft laterally. Prior to the 1971 models, the reference point for leveling the aircraft longitudinally is the top of the tailcone between the rear window and vertical fin. Beginning with the 1971 models, the reference points for longitudinal leveling of the aircraft are the two screws on the left side of the tailcone at zero waterline.

2-6. **PARKING.** Parking precautions depend principally on local conditions. As a general precaution, set parking brake or chock the wheels and install the controls lock. In severe weather and high wind conditions, tie down the aircraft as outlined in paragraph 2-7 if a hangar is not available.

2-7. **TIE-DOWN.** When mooring the aircraft in the open, head into the wind if possible. Secure control surfaces with the internal control lock and set brakes.

CAUTION

Do not set parking brakes during cold weather when accumulated moisture may freeze the brakes or when the brakes are overheated.

After completing the preceding, proceed to moor the aircraft as follows:

- a. Tie ropes, cables, or chains to the wing tie-down fittings located at the upper end of each wing strut. Secure the opposite ends of ropes, cables, or chains to ground anchors.
- b. Secure a tie-down rope (no chains or cables) to the exposed portion of the engine mount and secure opposite end of rope to a ground anchor.
- c. Secure the middle of a rope to the tail tie-down ring. Pull each end of rope away at a 45 degree angle and secure to ground anchors at each side of tail.
- d. Secure control lock on pilot control column. If control lock is not available, tie pilot control wheel back with front seat belt.
- e. These aircraft are equipped with a spring-loaded steering system which affords protection against normal wind gusts. However, if extremely high wind gusts are anticipated, additional external locks may be installed.

2-8. **FLYABLE STORAGE.** Flyable storage is defined as a maximum of 30 days non-operational storage and/or the first 25 hours of intermittent engine

operation.

NOTE

The aircraft is delivered from Cessna with a Corrosion Preventive Aircraft Engine Oil (MIL-C-6529, Type II, RUST BAN). This engine oil is a blend of aviation grade straight mineral oil and a corrosion preventive compound. This engine oil should be used for the first 50 hours of engine operation. In the event it is necessary to add oil during the first 25 hours of operation, use only aviation grade straight mineral oil of the correct viscosity.

During the 30 day non-operational storage or the first 25 hours of intermittent engine operation, every seventh day the propeller shall be rotated through five revolutions, without running the engine. If the aircraft is stored outside, tie-down in accordance with paragraph 2-7. In addition, the pitot tube, static airvents, air vents, openings in the engine cowling, and other similar openings shall have protective covers installed to prevent entry of foreign material. After 30 days, aircraft should be flown for 30 minutes or ground run-up until oil has reached operating temperature.

2-9. **RETURNING AIRCRAFT TO SERVICE.** After flyable storage, returning the aircraft to service is accomplished by performing a thorough pre-flight inspection. At the end of the first 25 hours of engine operation, drain engine oil, clean oil screens and change external oil filter element. Service engine with correct grade and quantity of engine oil. Refer to figure 2-4 and paragraph 2-21 for correct grade of engine oil.

2-10. **TEMPORARY STORAGE.** Temporary storage is defined as aircraft in a non-operational status for a maximum of 90 days. The aircraft is constructed of corrosion resistant alclad aluminum, which will last indefinitely under normal conditions if kept clean, however, these alloys are subject to oxidation. The first indication of corrosion on unpainted surfaces is in the form of white deposits or spots. On painted surfaces, the paint is discolored or blistered. Storage in a dry hangar is essential to good preservation and should be procured if possible. Varying conditions will alter the measures of preservation, but under normal conditions in a dry hangar, and for storage periods not to exceed 90 days, the following methods of treatment are suggested:

- a. Fill fuel tanks with correct grade of gasoline.
- b. Clean and wax aircraft thoroughly.
- c. Clean any oil or grease from tires and coat tires with a tire preservative. Cover tires to protect against grease and oil.
- d. Either block up fuselage to relieve pressure on tires or rotate wheels every 30 days to change supporting points and prevent flat spotting the tires.
- e. Lubricate all airframe items and seal or cover all openings which could allow moisture and/or dust to enter.

NOTE

The aircraft battery serial number is recorded in the aircraft equipment list. To assure accurate warranty records, the battery should be re-installed in the same aircraft from which it was removed. If the battery is returned to service in a different aircraft, appropriate record changes must be made and notification sent to the Cessna Claims Department.

f. Remove battery and store in a cool dry place; service the battery periodically and charge as required.

NOTE

An engine treated in accordance with the following may be considered protected against normal atmospheric corrosion for a period not to exceed 90 days.

g. Disconnect spark plug leads and remove upper and lower spark plugs from each cylinder.

NOTE

The preservative oil must be Lubricating Oil-Contact and Volatile, Corrosion Inhibited, MIL-L-46002, Grade 1 or equivalent. The following oils are approved for spraying operations by Teledyne Continental Motors, Nucle Oil 105 - Daubert Chemical Co., 4700 So. Central Ave., Chicago, Illinois, Petractec VA - Pennsylvania Refining Co., Butler Pennsylvania. Ferro-Gard 1009G - Ranco Laboratories, Inc., 3617 Brownsville Rd., Pittsburgh, Pennsylvania.

h. Using a portable pressure sprayer, atomize spray preservative oil through the upper spark plug hole of each cylinder with the piston in a down position. Rotate crankshaft as each pair of cylinders is sprayed.

i. After completing step "h," rotate crankshaft so that no piston is at a top position. If the aircraft is to be stored outside, stop two-bladed propeller so that blades are as near horizontal as possible to provide maximum clearance with passing aircraft.

j. Again spray each cylinder without moving the crankshaft to thoroughly cover all interior surfaces of the cylinder above the piston.

k. Install spark plugs and connect spark plug leads.

l. Apply preservative oil to the engine interior by spraying approximately two ounces of the preservative oil through the oil filler tube.

m. Seal all engine openings exposed to the atmosphere using suitable plugs or non-hygroscopic tape. Attach a red streamer at each point that a plug or tape is installed.

n. If the aircraft is to be stored outside, perform the procedures outlined in paragraph 2-7. In addition, the pitot tube, static source vents, air vents, openings in the engine cowling and other similar

openings should have protective covers installed to prevent entry of foreign material.

o. Attach a warning placard to the propeller to the effect that the propeller shall not be moved while the engine is in storage.

2-11. INSPECTION DURING STORAGE.

a. Inspect airframe for corrosion at least once a month and remove dust collections as frequently as possible. Clean and wax as required.

b. Inspect the interior of at least one cylinder through the spark plug hole for corrosion at least once a month.

NOTE

Do not move crankshaft when inspecting interior of cylinder for corrosion.

c. If at the end of the 90 day period, the aircraft is to be continued in non-operational storage, again perform the procedural steps "g thru o" of paragraph 2-10.

2-12. RETURNING AIRCRAFT TO SERVICE. After temporary storage, use the following procedures to return the aircraft to service.

a. Remove aircraft from blocks and check tires for proper inflation. Check for proper nose gear strut inflation.

b. Check battery and install.

c. Check that oil sump has proper grade and quantity of engine oil.

d. Service induction air filter and remove warning placard from propeller.

e. Remove materials used to cover openings.

f. Remove, clean, and gap spark plugs.

g. While spark plugs are removed, rotate propeller several revolutions to clear excess rust preventive oil from cylinders.

h. Install spark plugs. Torque spark plugs to 330 ±30 lb-in and connect spark plug leads.

i. Check fuel strainer. Remove and clean filter screen if necessary. Check fuel tanks and fuel lines for moisture and sediment, drain enough fuel to eliminate moisture and sediment.

j. Perform a thorough pre-flight inspection, then start and warm-up engine.

2-13. INDEFINITE STORAGE. Indefinite storage is defined as aircraft in a non-operational status for an indefinite period of time. Engines treated in accordance with the following may be considered protected against normal atmosphere corrosion, provided the procedures outlined in paragraph 2-14 are performed at the intervals specified.

a. Operate engine until oil temperature reaches normal operating range. Drain engine oil sump and reinstall drain plug.

b. Fill oil sump to normal operating capacity with corrosion preventive mixture which has been thoroughly mixed and pre-heated to a minimum of 221°F at the time it is added to the engine.

NOTE

Corrosion preventive mixture consists of one part compound MIL-C-6529, Type I, mixed with three parts new lubricating oil of the grade recommended for service. Continental Motors Corporation recommends Cosmoline No. 1223, supplied by E. F. Houghton & Co., 305 W. LeHigh Avenue, Philadelphia, Pa. During all spraying operation corrosion mixture is pre-heated to 221° to 250°F.

c. Immediately after filling the oil sump with corrosion preventive mixture, fly the aircraft for a period of time not to exceed a maximum of 30 minutes.

d. With engine operating at 1200 to 1500 rpm and induction air filter removed, spray corrosion preventive mixture into induction airbox, at the rate of one-half gallon per minute, until heavy smoke comes from exhaust stack, then increase the spray until the engine is stopped.

CAUTION

Injecting corrosion-preventive mixture too fast can cause a hydrostatic lock.

e. Do not rotate propeller after completing step "d."

f. Remove all spark plugs and spray corrosion-preventive mixture, which has been pre-heated to 221° to 250°F, into all spark plug holes to thoroughly cover interior surfaces of cylinders.

g. Install lower spark plug or install solid plugs, and install dehydrator plugs in upper spark plug holes. Be sure that dehydrator plugs are blue in color when installed.

h. Cover spark plug lead terminals with shipping plugs (AN4060-1) or other suitable covers.

i. With throttle in full open position, place a bag of desiccant in the carburetor intake and seal opening with moisture resistant paper and tape.

j. Place a bag of desiccant in the exhaust tail-pipe(s) and seal openings with moisture resistant tape.

k. Seal cold air inlet to the heater muff with moisture resistant tape.

l. Seal engine breather by inserting a protex plug in the breather hose and clamping in place.

m. Seal all other engine openings exposed to atmosphere using suitable plugs or non-hygroscopic tape.

NOTE

Attach a red streamer to each place plugs or tape is installed. Either attach red streamers outside of the sealed area with tape or to the inside of the sealed area with safety wire to prevent wicking of moisture into the sealed area.

n. Drain corrosion-preventive mixture from engine sump and reinstall drain plug.

NOTE

The corrosion-preventive mixture is harmful to paint and should be wiped from painted surfaces immediately.

o. Attach a warning placard on the throttle control knob, to the effect that the engine contains no lubricating oil. Placard the propeller to the effect that it should not be moved while the engine is in storage.

p. Prepare airframe for storage as outlined in paragraph 2-10 thru step "f."

NOTE

As an alternate method of indefinite storage, the aircraft may be serviced in accordance with paragraph 2-10 providing the aircraft is run-up at maximum intervals of 60 days and then reserviced per paragraph 2-10.

2-14. INSPECTION DURING STORAGE. Aircraft in indefinite storage shall be inspected as follows:

a. Inspect cylinder protex plugs each 7 days.

b. Change protex plugs if their color indicates an unsafe condition.

c. If the dehydrator plugs have changed color in one half of the cylinders, all desiccant material in the engine shall be replaced with new material.

d. Every 6 months respray the cylinder interiors with corrosion-preventive mixture.

NOTE

Before spraying, inspect the interior of one cylinder for corrosion through the spark plug hole and remove at least one rocker box cover and inspect the valve mechanism.

2-15. RETURNING AIRCRAFT TO SERVICE. After indefinite storage, use the following procedure to return the aircraft to service.

a. Remove aircraft from blocks and check tires for correct inflation. Check for correct nose gear strut inflation.

b. Check battery and install.

c. Remove all materials used to seal and cover openings.

d. Remove warning placards posted at throttle and propeller.

e. Remove and clean engine oil screen, then re-install and safety. On aircraft that are equipped with an external oil filter, install new filter element.

f. Remove oil sump drain plug and drain sump. Install and safety drain plug.

NOTE

The corrosion-preventive mixture will mix with the engine lubricating oil, so flushing the oil system is not necessary. Draining the oil sump will remove enough of the corrosion-preventive mixture.

- g. Service and install the induction air filter.
- h. Remove dehydrator plugs and spark plugs or plugs installed in spark plug holes and rotate propeller by hand several revolutions to clear corrosion-preventive mixture from cylinders.
 - i. Clean, gap, and install spark plugs. Torque plugs to the value listed in Section 11.
 - j. Check fuel strainer. Remove and clean filter screen. Check fuel tanks and fuel lines for moisture and sediment, and drain enough fuel to eliminate.
 - k. Perform a thorough pre-flight inspection, then start and warm-up engine.
 - 1. Thoroughly clean aircraft and flight test aircraft.

2-16. SERVICING.

2-17. Servicing requirements are shown in figure 2-4. The following paragraphs supplement this figure by adding details not included in the figure.

2-18. FUEL. Fuel tanks should be filled immediately after flight to lessen moisture condensation. Tank capacities are listed in Section 1. The recommended fuel grade to be used is given in figure 2-4.

2-19. FUEL DRAINS are located in the fuel tanks, fuel line, fuel strainer, and carburetor. Drain plugs are installed in the fuel tanks, fuel line forward of ON-OFF valve, and carburetor. The strainer drain valve is an integral part of the fuel strainer assembly. The strainer drain is equipped with a control which is located adjacent to the oil dipstick. Access to the control is through the oil dipstick access door. Remove drain plugs and open strainer drain at the intervals specified in figure 2-4. Also, during daily inspection of the fuel strainer, if water is found in the fuel strainer, there is a possibility that the wing tank sumps or fuel line contain water. Therefore, all fuel drain plugs should be removed and all water drained from the system. To activate drain valve for fuel sampling, place cup up to valve and depress valve with rod protruding from cup. See figure 12-3.

2-20. CARBURETOR DRAIN PLUG INSPECTION. In order to prevent the possibility of thread sealant contamination in the carburetor float chamber, cleaning and inspection of the carburetor should be accomplished at each 100-hour inspection and anytime water in the fuel is suspected.

- a. With the fuel valve OFF, remove carburetor drain plug and clean off any sealant present on the end of the plug or in the threads on the plug.
- b. Inspect drain plug hole in the carburetor and remove any sealant remaining in the hole.
- c. Turn fuel valve to ON to flush float chamber and drain plug chamber while probing drain plug hole to ascertain that all residue of sealant material is dislodged and washed out of the chamber. Flushing operation should last 15 to 30 seconds.
- d. A second flushing should then be accomplished and the drained fuel retained for inspection to insure that no sealant particles are present.
- e. Install drain plug as follows:
 - 1. Install drain plug in carburetor 1-1/2 to 2 turns.
 - 2. Apply sealant to drain plug threads (use

NS-40 (RAS-4) or equivalent).

- 3. Tighten and safety drain plug.
- f. Turn fuel valve ON and inspect for evidence of fuel leakage.

2-21. ENGINE OIL. Check engine lubricating oil with the oil dipstick five to ten minutes after the engine has been stopped. Engine oil should be drained while the engine is still hot so that more positive draining is obtained. Refer to the inspection charts for required intervals for oil and filter changes. Change oil every 6 months even though less than the specified hours have accumulated. Reduce these periods for prolonged operation in dusty areas, in cold climate where sludging conditions exist, or where short flights and long idle periods are encountered, which cause sludging conditions. Always change oil and install a new filter element or clean screens whenever oil on dipstick appears dirty.

NOTE

On aircraft equipped with an oil cooler, drain oil cooler at each oil change period. When oil cooler is drained and after the first engine run-up, check oil with dipstick and add oil as required to bring oil in the sump to the desired level.

Oil capacity is six quarts total with a normal operating capacity of five quarts for flights of less than three hours. For extended flight, fill to the six quart level on the dipstick. DO NOT operate with less than the minimum for flight quantity of four quarts. If the engine is equipped with an external oil filter, an additional quart of oil is required when the filter element is changed. When adding or changing engine oil, use aviation grade oil in accordance with figure 2-4.

NOTE

New or newly-overhauled engines should be operated on aviation grade straight mineral oil until the first oil change. If an ashless dispersant oil is used in a new or newly-overhauled engine, high oil consumption may be experienced. The anti-friction additives in ashless dispersant oils will retard "break-in" of the piston, rings and cylinder walls. This condition can be avoided by the use of straight mineral oil. The aircraft is delivered from Cessna with a Corrosion Preventive Aircraft Engine Oil (MIL-C-6529, Type II, RUST BAN). If oil must be added during the first 25 hours, use only aviation grade straight mineral oil (non-detergent) conforming to Specification No. MIL-L-6082. After the first 25 hours of operation, drain engine oil sump and clean both the oil suction strainer and oil pressure screen. If an optional oil filter is installed, change filter element at this time. Refill sump with straight mineral oil (non-detergent) and use until a total of 50 hours have accumulated or oil consumption has stabilized, then change to ashless dispersant oil, conforming with Continental Motors Specification MHS-24

and revisions and supplements thereto and with current Continental Aircraft Engine Service Bulletins.

Ashless dispersant oil, conforming with Continental Motors Specification MHS-24 and revisions and supplements thereto and with current Continental Aircraft Engine Service Bulletins, must be used at the oil change after 50 hours of operation. When changing engine oil, remove and clean oil screens, or install a new filter element on aircraft equipped with an external oil filter. An oil quick-drain valve may be installed. This valve provides a quick and cleaner method of draining the engine oil. The valve is installed in the oil drain port of the oil sump and allows the oil to be drained by inserting a hose over the fitting end and pushing up to lock the valve open, causing the oil to drain through the hose into a container. To drain the engine oil, proceed as follows:

- a. Operate engine until oil temperature is a normal operating temperature.
- b. (With Quick-Drain Valve.) Attach a hose to the quick-drain valve in the oil sump. Push up on quick-drain valve until it locks open, and allow oil to drain through hose into container.
- c. (Without Quick-Drain Valve.) Remove oil drain plug from oil sump and allow oil to drain into a container.
- d. After engine oil has drained, close quick-drain valve and remove hose, or install and safety drain plug.
- e. Remove and clean oil screens, or change external oil filter element.
- f. On aircraft equipped with an oil cooler, remove cooler drain plug and drain oil cooler at each oil change. After oil cooler has drained, install and safety drain plug.
- g. Service engine with correct quantity and grade of engine oil. (See figure 2-4).

NOTE

When oil cooler is drained or external filter element is changed and after the first engine run-up, check oil with dipstick and add oil as required to bring oil in the sump to the desired level.

2-22. ENGINE INDUCTION AIR FILTER. The induction air filter keeps dust and dirt from entering the induction system. The value of maintaining the air filter in a good clean condition can never be overstressed. More engine wear is caused through the use of dirty or damaged air filter than is generally believed. The frequency with which the filter should be removed, inspected, and cleaned will be determined primarily by aircraft operating conditions. A good general rule however, is to remove, inspect and clean the filter at least every 50 hours of engine operating time and more frequently if warranted by operating conditions. Some operators prefer to hold a spare induction air filter at their home base of opera-

tion so that a clean filter is always readily available for use. Under extremely dusty conditions, daily servicing of the filter is recommended. Two types of filters are used. One is a flock-coated, oiled filter and the other is a dry, paper-media filter.

NOTE

The aircraft is equipped with the flock-coated, oiled filter when it leaves the factory. However, new filters ordered from the Cessna Service Parts Center will be the dry, paper-media filter with an improved element.

To service the flock-coated, oiled filter, proceed as follows:

- a. Remove filter from aircraft.
- b. Wash filter thoroughly in solvent (Federal Specification P-S-661 or equivalent). Wash with soiled face down in solvent.
- c. Drain and dry filter, then dip flock-coated screen filter in the same grade of oil used in the engine and allow excess oil to drain from the filter.
- d. Be sure airbox is cleaned, inspect filter. If filter is damaged, install a new filter.

NOTE

A damaged filter may have broken filtering panels or the flock coating may be missing from the filtering panels, which will allow unfiltered air to enter the induction system. Any filter that appears doubtful, shall have a new filter installed in its place.

- e. Install filter at entrance to air box with gasket on aft face of filter frame and with air flow arrow on filter pointed in the correct direction.

To service the dry type filter, proceed as follows:

- a. Remove filter from aircraft.

NOTE

Use care to prevent damage to filter element when cleaning filter with compressed air.

- b. Clean filter by blowing with compressed air (not over 100 psi) from direction opposite of normal air flow. Arrows on filter case indicate direction of normal air flow.

CAUTION

Do not use solvent or cleaning fluids to wash filter. Use only a water and household detergent solution when washing the filter.

- c. After cleaning as outlined in step "b", the filter may be washed, if necessary, in a solution of warm water and a mild household detergent. A cold water solution may be used.

NOTE

The filter assembly may be cleaned with compressed air a maximum of 30 times or it may be washed a maximum of 20 times. A new filter should be installed after using 500 hours of engine operating time or one year, whichever should occur first. However, a new filter should be installed at anytime it is damaged. A damaged filter may have sharp or broken edges in the filtering panels which would allow unfiltered air to enter the induction system. Any filter that appears doubtful, shall have a new filter installed in its place.

d. After washing, rinse filter with clear water until rinse water draining from filter is clear. Allow water to drain from filter and dry with compressed air (not over 100 psi).

NOTE

The filtering panels of the filter may become distorted when wet, but they will return to their original shape when dry.

e. Be sure air box is clean, inspect filter. If filter is damaged, install a new filter.

f. Install filter at entrance to air box with gasket on aft face of filter frame and with air flow arrow on filter frame pointed in the correct direction.

2-23. VACUUM SYSTEM FILTER. The vacuum system central air filter keeps dust and dirt from enter-

ing the vacuum operated instruments. Change central air filter element every 500 hours of operating time and whenever suction gage reading drops below 4.6 inches of mercury. Also, do not operate the vacuum system with the filter removed, or a vacuum line disconnected as particles of dust or other foreign matter may enter the system and damage the gyros.

2-24. BATTERY. Battery servicing involves adding distilled water to maintain the electrolyte level even with the horizontal baffle plate or split ring at the bottom of the filler holes, checking cable connections, and neutralizing and cleaning off any spilled electrolyte or corrosion. Use bicarbonate of soda (baking soda) and clean water to neutralize electrolyte or corrosion. Follow with a thorough flushing with clean water. Do not allow bicarbonate of soda to enter battery. Brighten cable and terminal connections with a wire brush, then coat with petroleum jelly before connecting cables. Check the battery every 50 hours (or at least every 30 days), oftener in hot weather. Add only distilled water, not acid or "rejuvenators", to maintain electrolyte level in the battery. Inspect the battery box and surrounding area and clean and remove any evidence of corrosion. Refer to Section 16 for detailed battery removal, installation, and testing.

2-25. TIRES. Maintain tire pressure at the air pressure specified in figure 1-1. When checking tire pressure, examine tires for wear, cuts, bruises, and slippage. Remove oil, grease and mud from tires with soap and water.

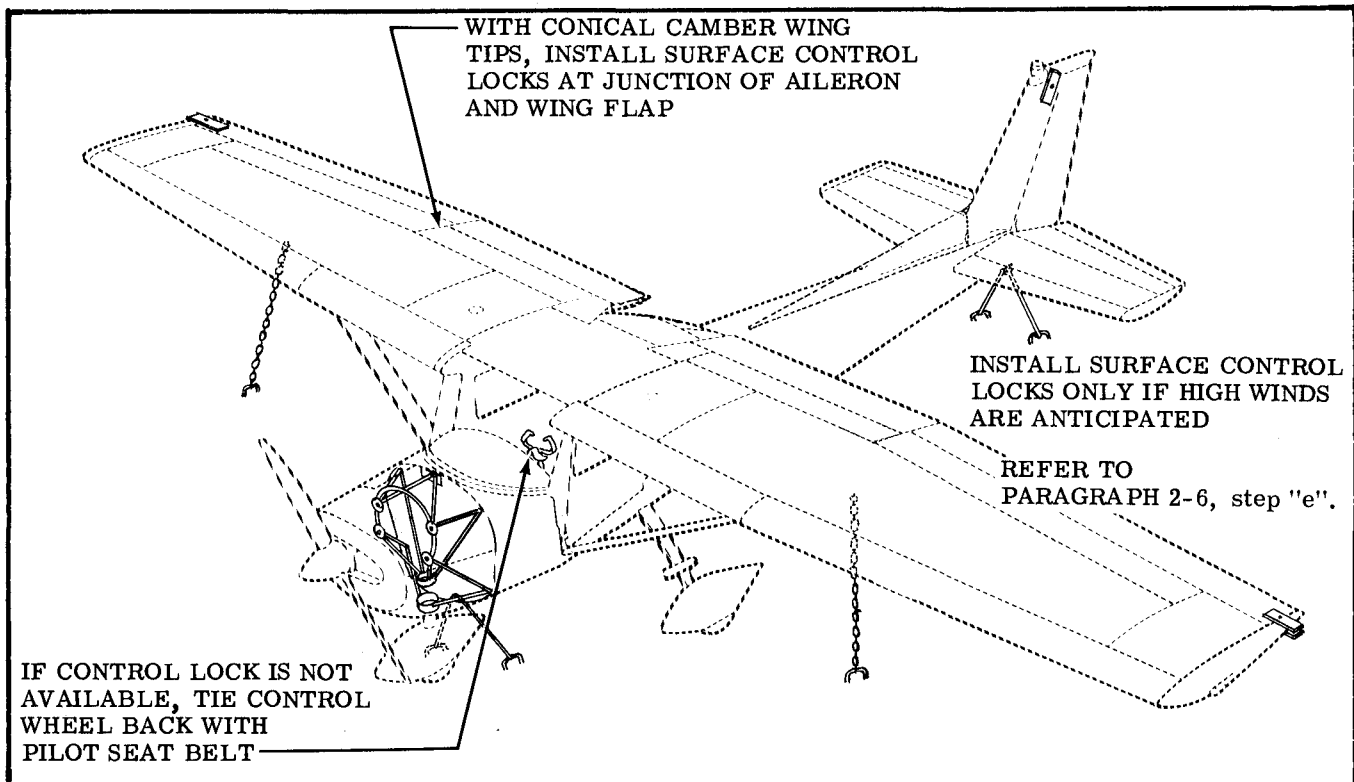

Figure 2-3. Tie-Down Details

NOTE

Recommended tire pressures should be maintained. Especially in cold weather, remember that any drop in temperature of the air inside a tire causes a corresponding drop in air pressure.

2-26. NOSE GEAR SHOCK STRUT. The nose gear shock strut requires periodic checking to ascertain that the strut is filled with hydraulic fluid and is inflated to the correct air pressure. To fill the nose gear strut with hydraulic fluid and inflate with air, proceed as follows:

- a. Remove filler valve cap and depress valve core to completely deflate nose strut.
- b. Remove filler valve from strut.
- c. With nose gear strut compressed to its shortest length, fill strut with hydraulic fluid to the bottom of the filler hole.
- d. Raise nose of aircraft, extend and compress strut several times to expel any entrapped air, then lower nose of aircraft and repeat step "c".
- e. With strut compressed to its shortest length, install filler valve assembly.
- f. With nose wheel off ground, inflate strut. Shock strut pressure is listed in figure 1-1.

NOTE

The nose landing gear shock strut will normally require only a minimum amount of service. Maintain the strut extension pressure, as shown in figure 1-1. Lubricate landing gear as shown in figure 2-5. Check the landing gear daily for general cleanliness, security of mounting, and for hydraulic fluid leakage. Keep machined surfaces wiped free of dirt and dust, using a clean lint-free cloth saturated with MIL-H-5606 hydraulic fluid or kerosene. All surfaces should be wiped free of excessive hydraulic fluid.

2-27. NOSE GEAR SHIMMY DAMPENER. The shimmy dampener should be serviced at least every 50 hours. The shimmy dampener must be filled completely with fluid, free of entrapped air, to serve its purpose. To service the shimmy dampener, proceed as follows:

- a. Remove shimmy dampener from aircraft.
- b. While holding the dampener in a vertical position with fitting end pointed downward, pull fitting end of the dampener shaft to its limit of travel.
- c. While holding dampener in this position, fill dampener through open end of cylinder.
- d. Push the shaft upward slowly to seal off the filler hole.
- e. Clean dampener with solvent. Be sure to keep the shaft protruding through the filler hole until dampener is installed on the aircraft.
- f. Install dampener on aircraft.

NOTE

Keep shimmy dampener, especially the exposed portions of the dampener piston shaft,

clean to prevent collection of dust and grit which could cut the seals in the dampener barrel. Keep machined surfaces wiped free of dirt and dust, using a clean lint-free cloth saturated with MIL-H-5606 hydraulic fluid or kerosene. All surfaces should be wiped free of excessive hydraulic fluid.

2-28. HYDRAULIC BRAKE SYSTEMS. Check brake master cylinders and refill with hydraulic fluid as specified in the inspection charts. Bleed the brake system of entrapped air whenever there is a spongy response to the brake pedals. Refer to paragraph 5-58 for filling and bleeding the brake system.

2-29. CLEANING.

2-30. Keeping the aircraft clean is important. Besides maintaining the trim appearance of the aircraft, cleaning lessens the possibility of corrosion and makes inspection and maintenance easier.

2-31. WINDSHIELD AND WINDOWS should be cleaned carefully with plenty of fresh water and a mild detergent, using the palm of the hand to feel and dislodge any caked dirt or mud. A sponge, soft cloth, or chamois may be used, but only as a means of carrying water to the plastic. Rinse thoroughly, then dry with a clean moist chamois. Do not rub the plastic with a dry cloth as this builds up an electrostatic charge which attracts dust. Oil and grease may be removed by rubbing lightly with a soft cloth moistened with Stoddard solvent.

CAUTION

Do not use gasoline, alcohol, benzene, acetone, carbon tetrachloride, fire extinguisher fluid, de-icer fluid, lacquer thinner, or glass window cleaning spray. These solvents will soften and craze the plastic.

After washing, the plastic windshield and windows should be cleaned with an aircraft windshield cleaner. Apply the cleaner with soft cloths and rub with moderate pressure. Allow the cleaner to dry, then wipe it off with soft flannel cloths. A thin, even coat of wax, polished out by hand with soft flannel cloths, will fill in minor scratches and help prevent further scratching. Do not use a canvas cover on the windshield or windows unless freezing rain or sleet is anticipated since the cover may scratch the plastic surface.

2-32. PLASTIC TRIM. The instrument panel, plastic trim, and control knobs need only be wiped with a damp cloth. Oil and grease on the control wheel and control knobs can be removed with a cloth moistened with Stoddard solvent. Volatile solvents, such as mentioned in paragraph 2-31, must never be used since they soften and craze the plastic.

2-33. PAINTED SURFACES. The painted exterior surfaces of the aircraft, under normal conditions, require a minimum of polishing and buffing. Approximately 15 days are required for acrylic or lacquer paint to cure completely; in most cases, the curing

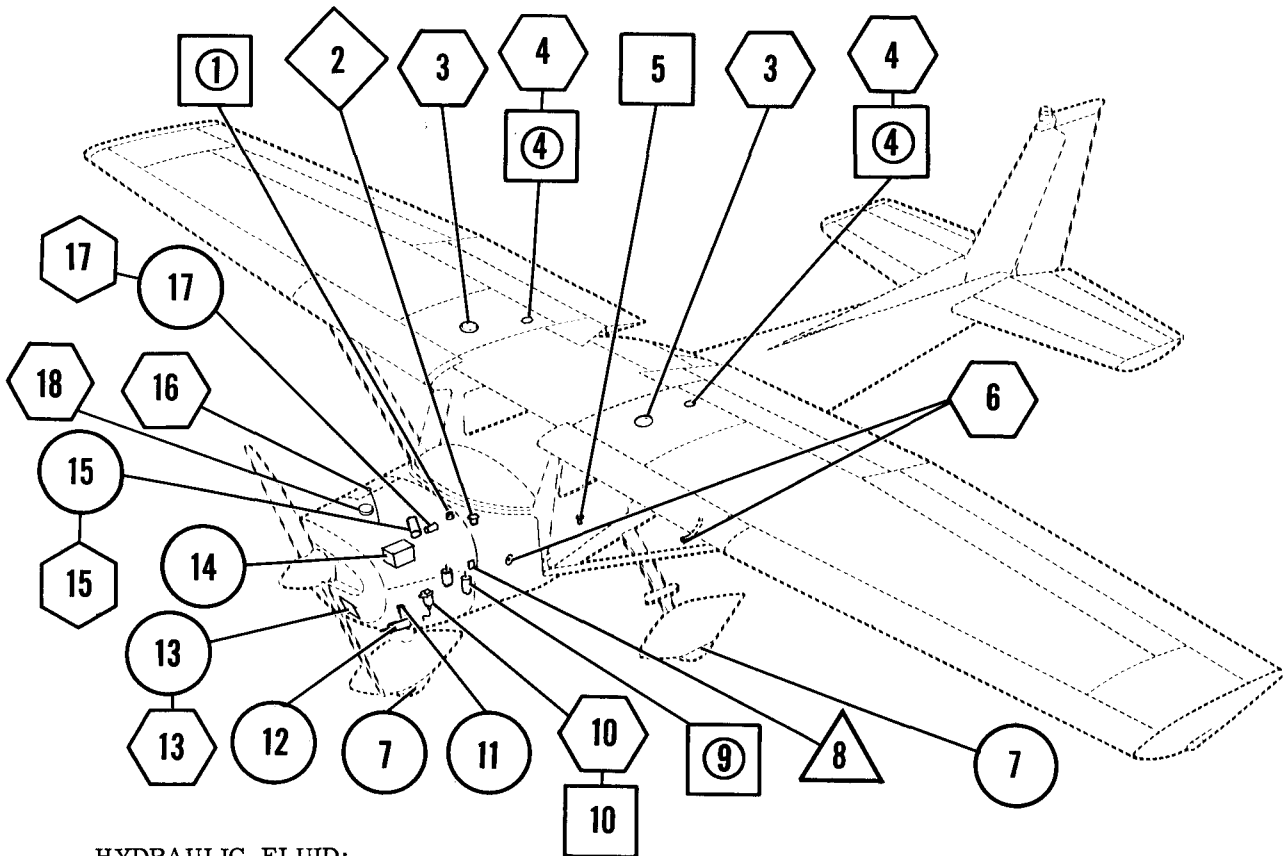

HYDRAULIC FLUID:
SPEC. NO. MIL-H-5606

RECOMMENDED FUEL:

CAUTION

* Compliance with conditions stated in Continental aircraft engine Service Bulletins M74-6 and M75-2 and supplements or revisions thereto, are recommended when using alternate fuel.

FUEL: MINIMUM: 80/87 Aviation Grade

*ALTERNATES:

1. 100/130 Low Lead Avgas (with lead content limited to a maximum of 2 cc Tetraethyllead per gallon)
2. 100/130 Higher Lead Avgas (with lead content limited to a maximum of 4.6 cc Tetraethyllead per gallon)

RECOMMENDED ENGINE OIL:

AVIATION GRADE:

ABOVE 40°F	SAE 40
BELOW 40°F	SAE 20

Aviation Grade ashless dispersant oil conforming to Continental Motors Specification MHS-24 and all revisions and supplements thereto must be used except as noted in paragraph 2-21. Refer to Continental Aircraft Engine Service Bulletin M74-19 and any superseding bulletins, revisions, or supplements thereto for further recommendations.

Figure 2-4. Servicing (Sheet 1 of 3)



DAILY

- 3 FUEL TANK FILLER
Service after each flight. Keep full to retard condensation. Refer to paragraph 2-18 for details.
- 4 FUEL TANK SUMP DRAINS
If quick-drain valves are installed, drain off any water and sediment before first flight of the day.
- 6 PITOT AND STATIC PORTS
Check for obstructions before first flight of the day.
- 10 FUEL STRAINER
Drain off any water and sediment before the first flight of the day. Refer to paragraph 2-19 for details.
- 13 INDUCTION AIR FILTER
Inspect and service under dusty conditions. Refer to paragraph 2-22 for details.
- 16 OIL DIPSTICK
Check oil on preflight. Add oil as necessary. Refer to paragraph 2-21 for details.
- 18 OIL FILLER CAP:
Whenever oil is added, check that filler cap is tight and oil filler door is secure.



FIRST 25 HOURS

- 15, 17 ENGINE OIL SYSTEM
Refill with straight mineral oil, non-detergent, and use until a total of 50 hours have accumulated or oil consumption has stabilized, then change to ashless dispersant oil.



50 HOURS

- 13 INDUCTION AIR FILTER
Clean filter per paragraph 2-22. Replace as required.
- 14 BATTERY
Check electrolyte level and clean battery compartment each 50 hours or each 30 days.
- 15, 17 ENGINE OIL SYSTEM
Change oil each 50 hours if engine is NOT equipped with external oil filter; if equipped with external oil filter, change filter element each 50 hours and oil at each 100 hours, or every 6 months.
- 12 SHIMMY DAMPENER
Check fluid level and refill as required with hydraulic fluid. Refer to paragraph 2-27 for details.
- 7 TIRES
Maintain correct tire inflation as listed in figure 1-1. Also refer to paragraph 2-25 for details.

Figure 2-4. Servicing (Sheet 2 of 3)



50 HOURS (Cont)

11 NOSE GEAR SHOCK STRUT

Keep strut filled and inflate to correct pressure. Refer to paragraph 2-26 for details.



100 HOURS

5 SHUT-OFF VALVE DRAIN

Remove plug and drain off any water or sediment. Also refer to paragraph 2-19.

10 FUEL STRAINER

Disassemble and clean strainer bowl and screen.



200 HOURS

1 VACUUM RELIEF FILTER

Change each 1000 hours, or to coincide with engine overhauls.

4 FUEL TANK SUMP DRAINS

If quick-drain valves are not installed, remove plugs and drain off any water or sediment. Reinstall plugs and safety. Also refer to paragraph 2-19.

9 BRAKE MASTER CYLINDERS

Check fluid level and refill as required with hydraulic fluid. Refer to paragraph 2-28 for details.

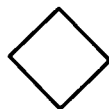

500 HOURS

2 VACUUM SYSTEM CENTRAL AIR FILTER

Replace every 500 hours.



AS REQUIRED

8 GROUND SERVICE RECEPTACLE

Connect to 12-volt DC, negative-ground power unit. Refer to Section 11 for details.

Figure 2-4. Servicing (Sheet 3 of 3)

period will have been completed prior to delivery of the aircraft. In the event that polishing or buffing is required within the curing period, it is recommended that the work be done by an experienced painter. Generally, the painted surfaces can be kept bright by washing with water and mild soap, followed by a rinse with water and drying with cloths or chamois. Harsh or abrasive soaps or detergents which could cause corrosion or make scratches should never be used. Remove stubborn oil and grease with a cloth moistened with Stoddard solvent. After the curing period, the aircraft may be waxed with a good automotive wax. A heavier coating of wax on the leading edges of the wing and tail and on the engine nose cap will help reduce the abrasion encountered in these areas.

2-34. ALUMINUM SURFACES. The aluminum surfaces require a minimum of care, but should never be neglected. The aircraft may be washed with clean water to remove dirt and may be washed with non-alkaline grease solvents to remove oil and/or grease. Household type detergent soap powders are effective cleaners, but should be used cautiously since some of them are strongly alkaline. Many good aluminum cleaners, polishes, and waxes are available from commercial suppliers of aircraft products.

2-35. ENGINE AND ENGINE COMPARTMENT. The engine should be kept clean since dirty cooling fins and baffle plates can cause overheating of the engine. Also, cleaning is essential to minimize any danger of fire and provide for easier inspection of components. The entire engine cowling may be removed to facilitate engine and interior cowl cleaning. Wash down the engine and components with a suitable solvent, such as Stoddard solvent or equivalent, then dry thoroughly with compressed air.

CAUTION

Particular care should be given to electrical equipment before cleaning. Solvent should not be allowed to enter magnetos, starters, alternators, voltage regulators, and the like. Hence, these components should be protected before saturating the engine with solvent. Any fuel, oil, and air openings should be covered before washing the engine with solvent. Caustic cleaning solutions should not be used. After cleaning engine re-lubricate all control arms and moving parts.

2-36. UPHOLSTERY AND INTERIOR. Keeping the upholstery and interior clean prolongs upholstery fabric and interior trim life. To clean the interior, proceed as follows:

- a. Empty all ash trays and refuse containers.
- b. Brush or vacuum clean the upholstery and carpet to remove dust and dirt.
- c. Wipe leather and plastic trim with a damp cloth.
- d. Soiled upholstery fabrics and carpet may be cleaned with a foam-type detergent used according to the manufacturer's instructions.
- e. Oil spots and stains may be cleaned with household spot removers, used sparingly. Before using any solvent, read the instructions on the container

and test it on an obscure place in the fabric to be cleaned. Never saturate the fabric with volatile solvent; it may damage the padding and backing material.

f. Scrape sticky material from fabric with a dull knife, then spot clean the area.

2-37. PROPELLER. Wash hub and blades with a soft cloth and Stoddard cleaning solvent or equivalent, then dry thoroughly with compressed air. The propeller should be wiped occasionally with an oily cloth, then wiped with a dry cloth. In salt water areas this will assist in corrosion proofing the propeller.

2-38. WHEELS. The wheels should be washed periodically and examined for corrosion, chipped paint, and cracks or dents in the wheel halves or in the flanges or hubs. If defects are found remove and repair in accordance with Section 5. Discard cracked wheel halves, flanges or hubs and install new parts.

2-39. LUBRICATION.

2-40. Lubrication requirements are shown in figure 2-5. Before adding grease to grease fittings, wipe dirt from fitting. Lubricate until grease appears around parts being lubricated, and wipe excess grease from parts. The following paragraphs supplement figure 2-5 by adding details.

2-41. TACHOMETER DRIVE SHAFT. Refer to Section 15 for details on lubrication of shaft.

2-42. WHEEL BEARINGS. Clean and repack the wheel bearings at the first 100-hour inspection and at each 500-hour inspection thereafter. If more than the usual number of take-offs and landings are made, extensive taxiing is required, or the aircraft is operated in dusty areas or under seacoast conditions, cleaning and lubrication of the wheel bearings shall be accomplished at each 100-hour inspection.

2-43. NOSE GEAR TORQUE LINKS. Lubricate nose gear torque links every 50 hours. When operating in dusty conditions, more frequent lubrication is required.

2-44. WING FLAP ACTUATOR.

a. On aircraft prior to Serials 15072630, F15000739, A15000278 and FA15000133 not modified by Service Kit SK150-37B and SK150-41, proceed as follows:

1. At each 100 hour inspection, inspect wing flap actuator jack screw and ball retainer assembly for lubrication, and lubricate if required. Also, remove, clean and lubricate jack screw whenever actuator slippage is experienced. If lubrication is required, proceed as follows:

- a. Gain access to actuator by removing appropriate inspection plates on lower surface of wing.
- b. Expose jack screw by operating flaps to full-down position.
- c. Wipe a small amount of lubricant from jack screw with a rag and examine for condition. Lubricant should not be dirty, sticky, gummy or frothy in appearance.

d. Inspect wiped area on jack screw for presence of hard scale deposit. Previous wiping action will have exposed bare metal if no deposit is present.

FREQUENCY (HOURS)



METHOD OF APPLICATION



WHERE NO INTERVAL IS SPECIFIED, LUBRICATE AS REQUIRED AND WHEN ASSEMBLED OR INSTALLED.

NOTE

The military specifications listed are not mandatory, but are intended as guides in choosing satisfactory materials. Products of most reputable manufacturers meet or exceed these specifications.

LUBRICANTS

PG	SS-G-659	POWDERED GRAPHITE
GR	MIL-G-81322	GENERAL PURPOSE GREASE
GH	MIL-G-23827	AIRCRAFT AND INSTRUMENT GREASE
GL	MIL-G-21164	MOLYBDENUM DISULFIDE GREASE
OG	MIL-L-7870	GENERAL PURPOSE OIL
PL	VV-P-236	PETROLATUM
GS	MIL-S-8660	DC4 (DOW CORNING)
GP		NO. 10-WEIGHT, NON-DETERGENT OIL

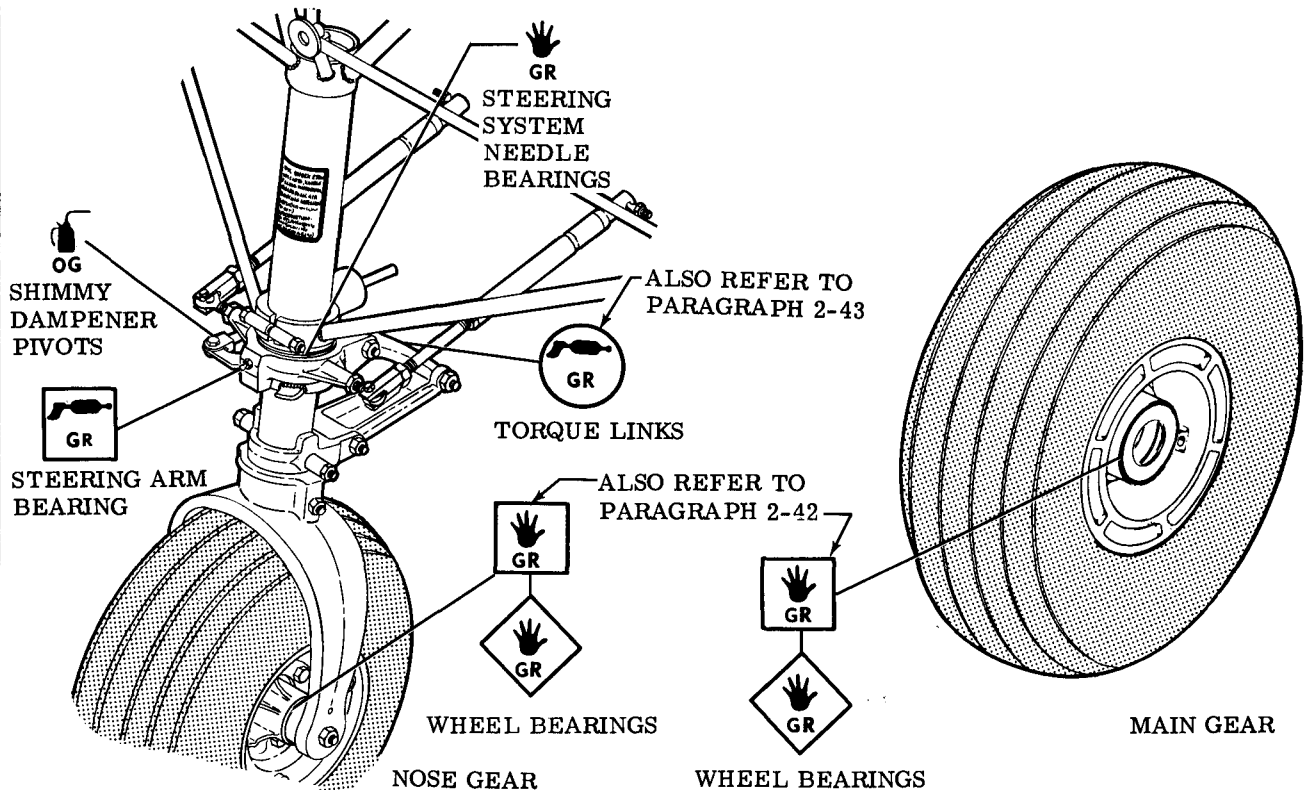

Figure 2-5. Lubrication (Sheet 1 of 3)

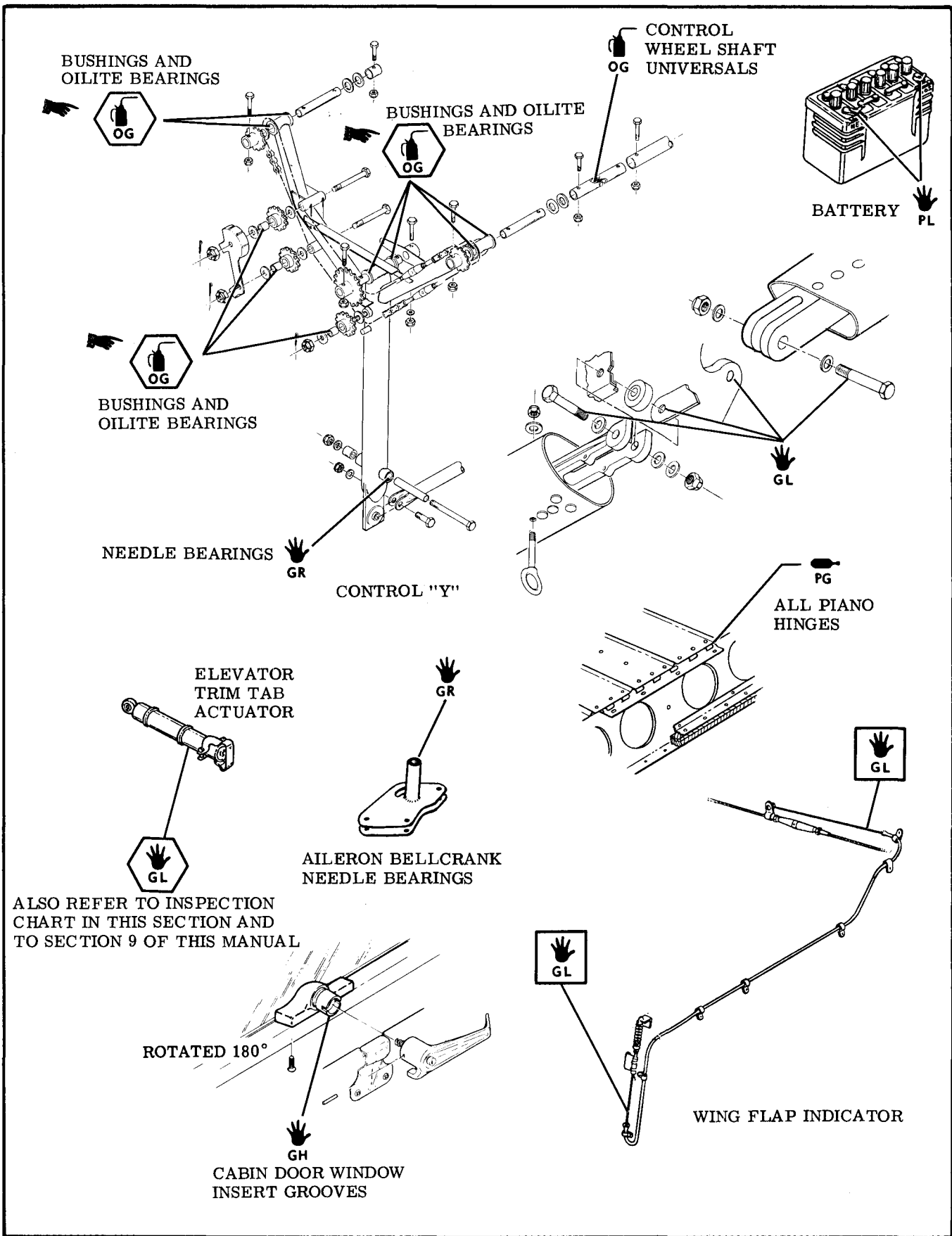

Figure 2-5. Lubrication (Sheet 2 of 3)

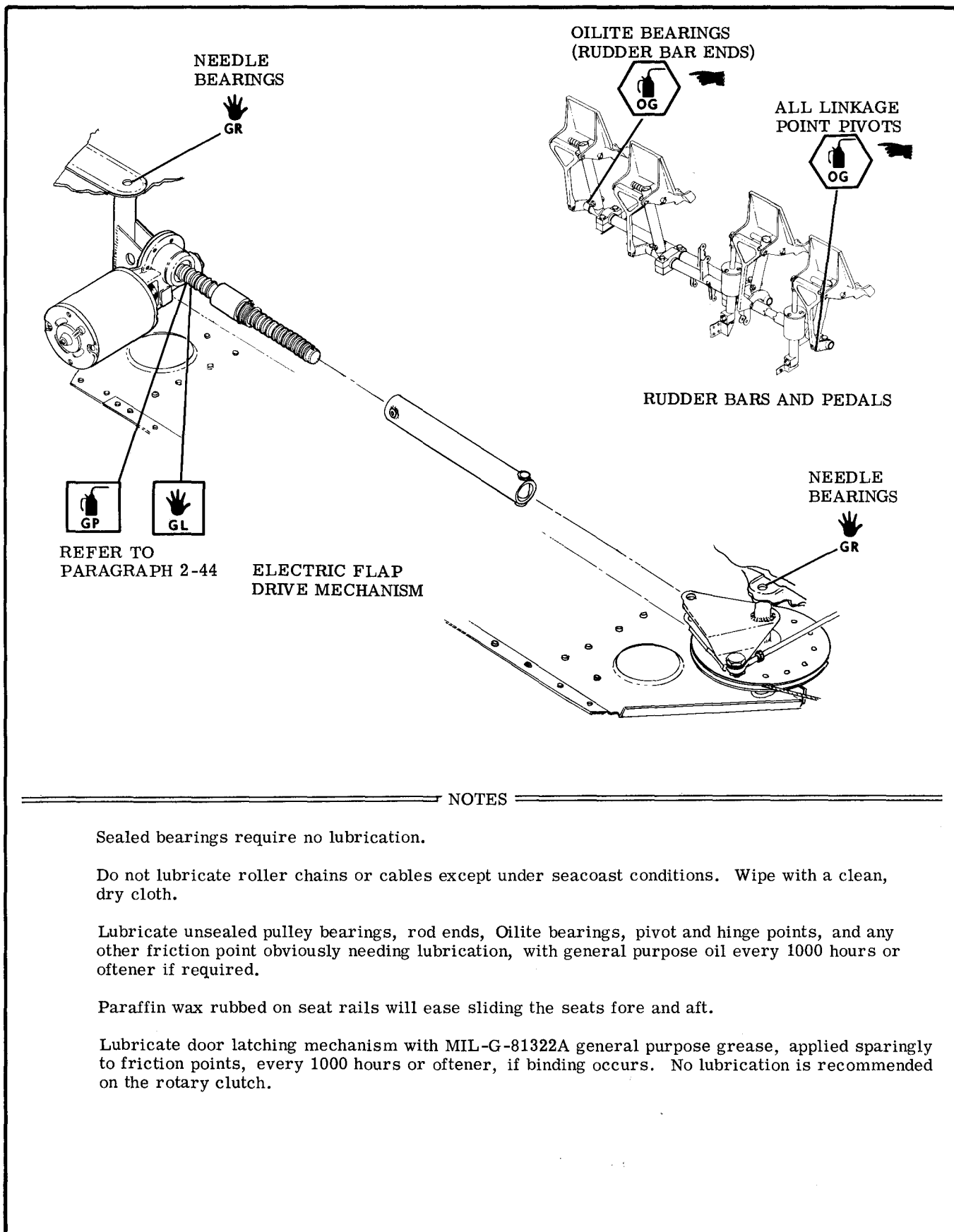

Figure 2-5. Lubrication (Sheet 3 of 3)

I INSPECTION REQUIREMENTS.

As required by Federal Aviation Regulations, all civil aircraft of U.S. registry must undergo a complete inspection (annual) each twelve calendar months. In addition to the required ANNUAL inspection, aircraft operated commercially (for hire) must also have a complete aircraft inspection every 100 hours of operation.

In lieu of the above requirements, an aircraft may be inspected in accordance with a progressive inspection schedule, which allows the work load to be divided into smaller operations that can be accomplished in shorter time periods.

Therefore, the Cessna Aircraft Company recommends PROGRESSIVE CARE for aircraft that are being flown 200 hours or more per year, and the 100 HOUR inspection for all other aircraft.

II INSPECTION CHARTS.

The following charts show the recommended intervals at which items are to be inspected.

As shown in the charts, there are items to be checked each 50 hours, each 100 hours, each 200 hours, and also Special Inspection items which require servicing or inspection at intervals other than 50, 100 or 200 hours.

- a. When conducting an inspection at 50 hours, all items marked under EACH 50 HOURS would be inspected, serviced or otherwise accomplished as necessary to insure continuous airworthiness.
- b. At each 100 hours, the 50 hour items would be accomplished in addition to the items marked under EACH 100 HOURS as necessary to insure continuous airworthiness.
- c. An inspection conducted at 200 hour intervals would likewise include the 50 hour items and 100 hour items in addition to those at EACH 200 HOURS.
- d. The numbers appearing in the SPECIAL INSPECTION ITEMS column refer to data listed at the end of the inspection charts. These items should be checked at each inspection interval to insure that applicable servicing and inspection requirements are accomplished at the specified intervals.
- e. A complete aircraft inspection includes all 50, 100 and 200 hour items plus those Special Inspection Items which are due at the time of the inspection.

III INSPECTION PROGRAM SELECTION.

AS A GUIDE FOR SELECTING THE INSPECTION PROGRAM THAT BEST SUITS THE OPERATION OF THE AIRCRAFT, THE FOLLOWING IS PROVIDED.

1. IF THE AIRCRAFT IS FLOWN LESS THAN 200 HOURS ANNUALLY.

a. IF FLOWN FOR HIRE

An aircraft operating in this category must have a complete aircraft inspection each 100 hours and each 12 calendar months of operation. A complete aircraft inspection consists of all 50, 100, 200 and Special Inspection Items shown in the inspection charts as defined in paragraph II above.

b. IF NOT FLOWN FOR HIRE

An aircraft operating in this category must have a complete aircraft inspection each 12 calendar months (ANNUAL). A complete aircraft inspection consists of all 50, 100, 200 and Special Inspection Items shown in the inspection charts as defined in paragraph II above. In addition, it is recommended that between annual inspections, all items be inspected at the intervals specified in the inspection charts.

2. IF THE AIRCRAFT IS FLOWN MORE THAN 200 HOURS ANNUALLY.

Whether flown for hire or not, it is recommended that aircraft operating in this category be placed on the CESSNA PROGRESSIVE CARE PROGRAM. However, if not placed on Progressive Care, the inspection requirements for aircraft in this category are the same as those defined under paragraph III 1. (a) and (b).

Cessna Progressive Care may be utilized as a total concept program which insures that the inspection intervals in the inspection charts are not exceeded. Manuals and forms which are required for conducting Progressive Care inspections are available from the Cessna Service Parts Center.

IV INSPECTION GUIDE LINES.

- (a) **MOVABLE PARTS** for: lubrication, servicing, security of attachment, binding, excessive wear, safetying, proper operation, proper adjustment, correct travel, cracked fittings, security of hinges, defective bearings, cleanliness, corrosion, deformation, sealing and tension.
- (b) **FLUID LINES AND HOSES** for: leaks, cracks, dents, kinks, chafing, proper radius, security, corrosion, deterioration, obstruction and foreign matter.
- (c) **METAL PARTS** for: security of attachment, cracks, metal distortion, broken spotwelds, corrosion, condition of paint and any other apparent damage.
- (d) **WIRING** for: security, chafing, burning, defective insulation, loose or broken terminals, heat deterioration and corroded terminals.
- (e) **BOLTS IN CRITICAL AREAS** for: correct torque in accordance with torque values given in the chart in Section 1, when installed or when visual inspection indicates the need for a torque check.

NOTE

Torque values listed in Section 1 are derived from oil-free cadmium-plated threads, and are recommended for all installation procedures contained in this book except where other values are stipulated. They are not to be used for checking tightness of installed parts during service.

- (f) **FILTERS, SCREENS & FLUIDS** for: cleanliness, contamination and/or replacement at specified intervals.
- (g) **AIRCRAFT FILE.**

Miscellaneous data, information and licenses are a part of the aircraft file. Check that the following documents are up-to-date and in accordance with current Federal Aviation Regulations. Most of the items listed are required by the United States Federal Aviation Regulations. Since the regulations of other nations may require other documents and data, owners of exported aircraft should check with their own aviation officials to determine their individual requirements.

To be displayed in the aircraft at all times:

1. Aircraft Airworthiness Certificate (FAA Form 8100-2).
2. Aircraft Registration Certificate (FAA Form 8050-3).
3. Aircraft Radio Station License, if transmitter is installed (FCC Form 556).

To be carried in the aircraft at all times:

1. Weight and Balance, and associated papers (Latest copy of the Repair and Alteration Form, FAA Form 337, if applicable).
2. Aircraft Equipment List.

To be made available upon request:

1. Aircraft Log Book and Engine Log Book.

(h) ENGINE RUN-UP.

Before beginning the step-by-step inspection, start, run up and shut down the engine in accordance with instructions in the Owner's Manual. During the run-up, observe the following, making note of any discrepancies or abnormalities:

1. Engine temperatures and pressures.
2. Static rpm. (Also refer to Section 11 of this Manual.)
3. Magneto drop. (Also refer to Section 11 of this Manual.)
4. Engine response to changes in power.
5. Any unusual engine noises.
6. Fuel selector and/or shut-off valve; operate engine(s) on each tank (or cell) position and OFF position long enough to ensure shut-off and/or selector valve functions properly.
7. Idling speed and mixture; proper idle cut-off.
8. Alternator and ammeter.
9. Suction gage.
10. Fuel flow indicator.

After the inspection has been completed, an engine run-up should again be performed to determine that any discrepancies or abnormalities have been corrected.

SHOP NOTES:

IMPORTANT
READ ALL INSPECTION REQUIREMENTS PARAGRAPHS PRIOR TO USING THESE CHARTS.

SPECIAL INSPECTION ITEM
EACH 200 HOURS
EACH 100 HOURS
EACH 50 HOURS

PROPELLER

- 1. Spinner
- 2. Spinner bulkhead
- 3. Blades
- 4. Bolts and/or nuts
- 5. Hub

ENGINE COMPARTMENT

Check for evidence of oil and fuel leaks, then clean entire engine and compartment, if needed, prior to inspection.

- 1. Engine oil, screen, filler cap, dipstick, drain plug and external filter element
- 2. Oil cooler
- 3. Induction air filter
- 4. Induction airbox, air valves, doors and controls
- 5. Cold and hot air hoses
- 6. Engine baffles
- 7. Cylinders, rocker box covers and push rod housings
- 8. Crankcase, oil sump, accessory section and front crankshaft seal
- 9. Hoses, metal lines and fittings
- 10. Intake and exhaust systems
- 11. Ignition harness
- 12. Spark plugs
- 13. Compression check
- 14. Crankcase and vacuum system breather lines
- 15. Electrical wiring
- 16. Vacuum pump and oil separator
- 17. Vacuum relief valve filter (cabin area)
- 18. Engine controls and linkage
- 19. Engine shock mounts, mount structure and ground straps
- 20. Cabin heat valves, doors and controls
- 21. Starter, solenoid and electrical connections

	●								
	●	●							1
	●	●	●						2
	●	●		●					
	●	●	●	●					3
	●	●	●	●	●				4
	●	●	●	●	●	●			
	●	●	●	●	●	●	●		5
	●	●	●	●	●	●	●	●	6
	●								

SPECIAL INSPECTION ITEM

EACH 200 HOURS

EACH 100 HOURS

EACH 50 HOURS

- 22. Starter brushes, brush leads and commutator ●
- 23. Alternator and electrical connections ●
- 24. Alternator brushes, brush leads and commutator or slip ring 7
- 25. Voltage regulator mounting and electrical leads ●
- 26. Magnetos (externally) and electrical connections ●
- 27. Magneto timing 8
- 28. Carburetor and drain plug ●
- 29. Firewall ●
- 30. Engine cowling ●

FUEL SYSTEM

- 1. Fuel strainer, drain valve and control ●
- 2. Fuel strainer screen and bowl ●
- 3. Fuel tank vents, caps and placards ●
- 4. Fuel tanks, sump drains and fuel line drains ●
- 5. Drain fuel and check tank interior, attachment and outlet screens 5
- 6. Fuel vent valves ●
- 7. Fuel vent line drain ●
- 8. Fuel shut-off valve and placards ●
- 9. Fuel valve drain plug ●
- 10. Engine primer ●

LANDING GEAR

- 1. Main gear wheels and fairings ●
- 2. Nose gear wheel, torque links, steering rods, boots and fairing ●
- 3. Wheel bearings 9
- 4. Nose gear strut and shimmy dampener (service as required) ●
- 5. Tires ●
- 6. Brake fluid, lines and hoses, linings, discs, brake assemblies and master cylinders ●
- 7. Parking brake system ●
- 8. Main gear springs ●

SPECIAL INSPECTION ITEM

EACH 200 HOURS

EACH 100 HOURS

EACH 50 HOURS

- 9. Nose steering arm lubrication
- 10. Torque link lubrication
- 11. Parking brake and toe brakes - operational check

AIRFRAME

- 1. Aircraft exterior
- 2. Aircraft structure
- 3. Windows, windshield, doors and seals
- 4. Seat belts and shoulder harnesses
- 5. Seat stops, seat rails, upholstery, structure and mounting
- 6. Control "Y" bearings, sprockets, pulleys, cables, chains and turnbuckles
- 7. Control lock, control wheel and control "Y" mechanism
- 8. Instruments and markings
- 9. Gyros central air filter
- 10. Magnetic compass compensation
- 11. Instrument wiring and plumbing
- 12. Instrument panel, shockmounts, ground straps, cover, decals and labeling
- 13. Defrosting, heating and ventilating systems and controls
- 14. Cabin upholstery, trim, sunvisors and ash trays
- 15. Area beneath floor, lines, hoses, wires and control cables
- 16. Lights, switches, circuit breakers, fuses and spare fuses
- 17. Exterior lights
- 18. Pitot and static systems
- 19. Stall warning system
- 20. Radios, radio controls, avionics and flight instruments
- 21. Antennas and cables
- 22. Battery, battery box and battery cables
- 23. Battery electrolyte
- 24. Emergency locator transmitter

●	
●	
●	
●	
●	
●	
●	
●	
●	
●	10
●	5
●	
●	
●	
●	
●	
●	
●	
●	
●	
●	
●	11
●	12

SPECIAL INSPECTION ITEM

EACH 200 HOURS

EACH 100 HOURS

EACH 50 HOURS

CONTROL SYSTEMS

In addition to the items listed below, always check for correct direction of movement, correct travel and correct cable tension.

1. Cables, terminals, pulleys, pulley brackets, cable guards, turnbuckles and fairleads			
2. Chains, terminals, sprockets and chain guards			
3. Trim control wheels, indicators, actuator and bungee	●		
4. Travel stops		●	
5. Decals and labeling			●
6. Flap control switch, flap rollers and tracks, flap indicator	●		
7. Flap motor, transmission, limit switches, structure, linkage, bellcranks, etc.			●
8. Elevator and trim tab hinges, tips and control rods	●		
9. Elevator trim tab actuator lubrication and tab free-play inspection			13
10. Rudder pedal assemblies and linkage			●
11. Skins (external) of control surfaces and tabs	●		
12. Internal structure of control surfaces			●
13. Balance weight attachment			●
14. Flap actuator jack screw threads			14

SPECIAL INSPECTION ITEMS

- 1 First 25 hours: Refill with straight mineral oil (non-detergent) and use until a total of 50 hours have accumulated or oil consumption has stabilized, then change to ashless dispersant oil. Change oil each 50 hours if engine is NOT equipped with external oil filter; if equipped with external oil filter, change filter element each 50 hours and oil at each 100 hours; or every 6 months.
- 2 Clean filters per paragraph 2-22. Replace as required.
- 3 Replace hoses at engine overhaul or after 5 years, whichever comes first.
- 4 General inspection every 50 hours. Refer to Section 11 for 100 hour inspection.
- 5 Each 1000 hours, or to coincide with engine overhauls.
- 6 Each 50 hours for general condition and freedom of movement. These controls are not repairable. Replace as required at each engine overhaul.
- 7 Each 500 hours.
- 8 INTERNAL TIMING: These magnetos cannot be overhauled or timed in the field. The coil, capacitor and breaker assembly are non-replaceable. As a good maintenance practice, and to have the benefit of good ignition at all times, it is recommended that the magnetos be removed at 900 hours of magneto time, and install new exchange magnetos.

MAGNETO-TO-ENGINE TIMING: First 50 hours, first 100 hours and each 200 hours thereafter.
- 9 First 100 hours and each 500 hours thereafter. More often if operated under prevailing wet or dusty conditions.
- 10 Replace each 500 hours.
- 11 Check electrolyte level and clean battery compartment each 50 hours or each 30 days.
- 12 Refer to Section 16 of this Manual.
- 13 Lubrication is required of the actuator each 1000 hours and/or 3 years, whichever comes first. Refer to figure 2-5 for grease specification.

Refer to Section 9 of this Manual for free-play limits, inspection, replacement and/or repair.
- 14 Refer to paragraph 2-44 for detailed instructions for various serial ranges.

NOTE

A high-time inspection is merely a 100-hour inspection with the addition of an engine overhaul. Continental recommends engine overhaul at 1800 hours for the O-200-series engine, except as stipulated in Continental aircraft engine Service Bulletin #M74-20 and supplements thereto. At the time of overhaul, engine accessories should be overhauled.

This page intentionally left blank.

SECTION 3

FUSELAGE

TABLE OF CONTENTS	Page		
FUSELAGE	3-1	Seats	3-7
Windshield and Windows	3-1	Pilot and Copilot	3-7
Description	3-1	Adjustable Back/Stationary	
Cleaning	3-1	Bottom	3-7
Waxing	3-1	Reclining Back/Fore-and-Aft	
Repairs	3-1	Adjustable Bottom	3-7
Scratches	3-1	Reclining Back/Fore-and-Aft and	
Cracks	3-2	Vertically Adjustable Bottom	3-7
Windshield	3-4	Description	3-7
Removal	3-4	Removal and Installation	3-7
Installation	3-4	Auxiliary	3-7
Windows	3-4	Description	3-7
Movable	3-4	Removal and Installation	3-7
Removal and Installation	3-4	Repair	3-7
Wrap-Around Rear	3-4	Cabin Upholstery	3-7
Removal and Installation	3-4	Materials and Tools	3-7
Overhead	3-4	Soundproofing	3-10
Removal and Installation	3-4	Cabin Headliner	3-11
Cabin Doors	3-4	Removal and Installation	3-11
Removal and Installation	3-4	Upholstery Side Panels	3-15
Adjustment	3-4	Carpeting	3-15
Weatherstrip	3-4	Baggage Compartment Upholstery	3-15
Wedge Adjustment	3-4	Safety Provisions	3-15
Cabin Door Latches	3-7	Cargo Tie-Down	3-15
Description	3-7	Safety Belts	3-15
Adjustment	3-7	Shoulder Harness Installation	3-15
Lock	3-7	Inertia Reel Harness	3-15
		Rear View Mirror	3-15

3-1. FUSELAGE.

3-2. WINDSHIELD AND WINDOWS.

3-3. DESCRIPTION. The windshield and windows are single-piece acrylic plastic panels set in sealing strips and held by formed retaining strips secured to the fuselage with screws and rivets. Presstite No. 579.6 sealing compound used in conjunction with a felt seal is applied to all edges of windshield and windows with exception of wing root area. The wing root fairing has a heavy felt strip which completes the windshield sealing.

3-4. CLEANING. (Refer to Section 2.)

3-5. WAXING. Waxing will fill in minor scratches in clear plastic and help protect the surface from further abrasion. Use a good grade of commercial wax applied in a thin, even coat. Bring wax to a high polish by rubbing lightly with a clean, dry flannel cloth.

3-6. REPAIRS. Damaged window panels and windshield may be removed and replaced if damage is extensive. However, certain repairs as prescribed in the following paragraphs can be made successfully without removing damaged part from aircraft. Three types of temporary repairs for cracked plastic are possible. No repairs of any kind are recommended on highly-stressed or compound curves where repair would be likely to affect pilot's field of vision. Curved areas are more difficult to repair than flat areas and any repaired area is both structurally and optically inferior to the original surface.

3-7. SCRATCHES. Scratches on clear plastic surfaces can be removed by hand-sanding operations followed by buffing and polishing, if steps below are followed carefully.

- a. Wrap a piece of No. 320 (or finer) sandpaper or abrasive cloth around a rubber pad or wood block. Rub surface around scratch with a circular motion, keeping abrasive constantly wet with clean water to prevent scratching surface further. Use minimum

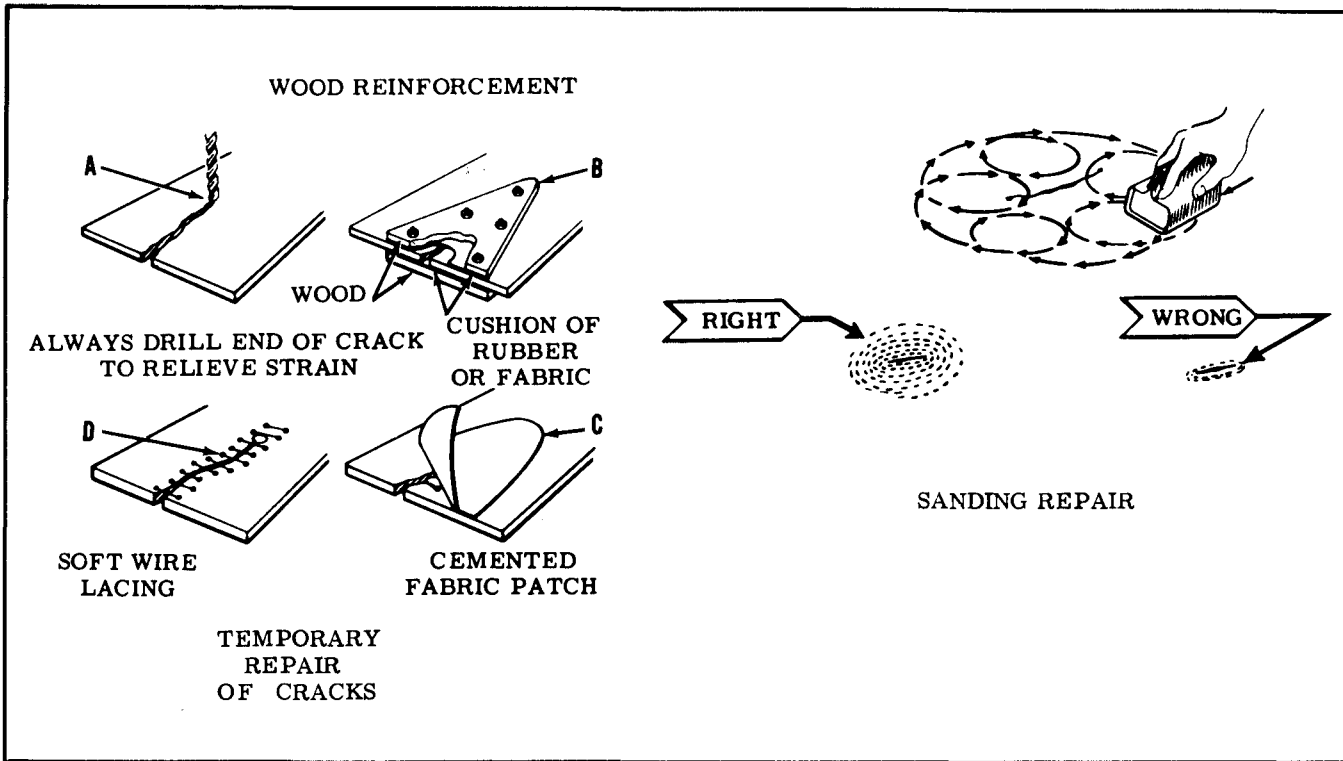

Figure 3-1. Repair of Windows and Windshield

pressure and cover an area large enough to prevent formation of "bull's-eyes" or other optical distortions.

CAUTION

Do not use a coarse grade of abrasive. No. 320 is of maximum coarseness.

- b. Continue sanding operation, using progressively finer grade abrasives until scratches disappear.
- c. When scratches have been removed, wash area thoroughly with clean water to remove all gritty particles. The entire sanded area will be clouded with minute scratches which must be removed to restore transparency.
- d. Apply fresh tallow or buffing compound to a motor-driven buffing wheel. Hold wheel against plastic surface, moving it constantly over damaged area until cloudy appearance disappears. A 2000-foot-per-minute surface speed is recommended to prevent overheating and distortion. (Example: 750 rpm polishing machine with a 10 inch buffing bonnet.)

NOTE

Polishing can be accomplished by hand but will require a considerably longer period of time to attain the same result as produced by a buffing wheel.

- e. When buffing is finished, wash area thoroughly and dry with a soft flannel cloth. Allow surface to cool and inspect area to determine if full transparency has been restored. Apply a thin coat of hard wax and polish surface lightly with a clean flannel

cloth.

NOTE

Rubbing plastic surface with a dry cloth will build up an electrostatic charge which attracts dirt particles and may eventually cause scratching of surface. After wax has hardened, dissipate this charge by rubbing surface with a slightly damp chamois. This will also remove dust particles which have collected while wax is hardening.

- f. Minute hairline scratches can often be removed by rubbing with commercial automobile body cleaner or fine-grade rubbing compound. Apply with a soft, clean, dry cloth or imitation chamois.

3-8. CRACKS. (Refer to figure 3-1.)

- a. When a crack appears, drill a hole at end of crack to prevent further spreading. Hole should be approximately 1/8 inch in diameter, depending on length of crack and thickness of material.
- b. Temporary repairs to flat surfaces can be accomplished by placing a thin strip of wood over each side of surface and inserting small bolts through wood and plastic. A cushion of sheet rubber or aircraft fabric should be placed between wood and plastic on both sides.
- c. A temporary repair can be made on a curved surface by placing fabric patches over affected areas. Secure patches with aircraft dope, Specification No. MIL-D-5549; or lacquer, Specification No. MIL-L-7178. Lacquer thinner, Specification No. MIL-T-6094 can also be used to secure patch.

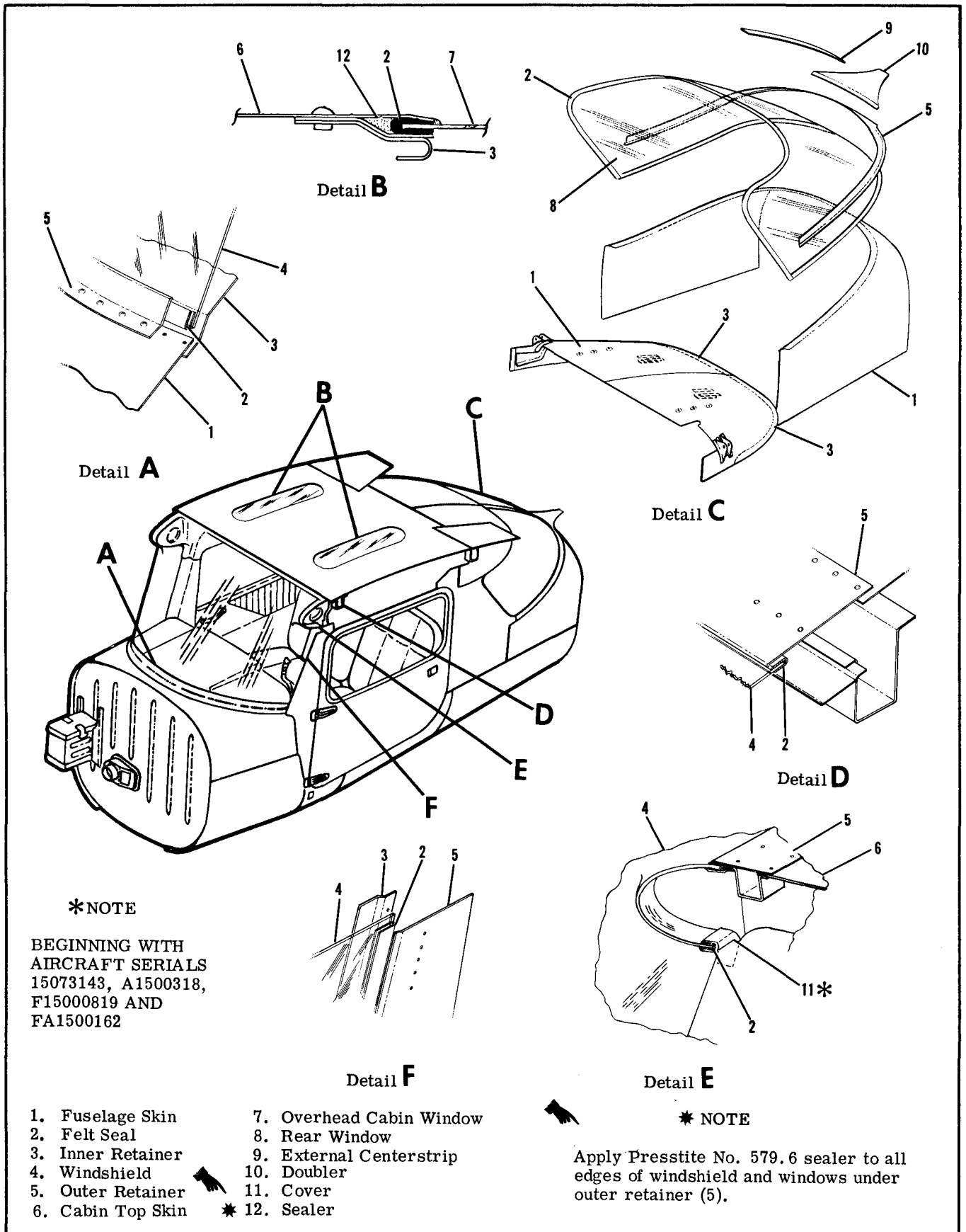

Figure 3-2. Windshield and Rear Window

lacing material. This type of repair is used as a temporary measure ONLY, and as soon as facilities are available, panel should be replaced.

3-9. WINDSHIELD. (Refer to figure 3-2.)

3-10. REMOVAL.

- a. Drill out rivets securing front retainer strip.
- b. Remove wing fairings over windshield edges.

NOTE

Remove and tape compass clear of work area. Do not disconnect electrical wiring.

- c. Pull windshield straight forward, out of side and top retainers. Remove top retainer if necessary.

3-11. INSTALLATION.

- a. Apply felt strip and sealing compound or sealing tape to all edges of windshield to prevent leaks.
- b. Reverse steps in preceding paragraph for installation.
- c. When installing a new windshield, check fit and carefully file or grind away excess plastic.
- d. Use care not to crack windshield when installing. If not previously removed, top retainer may be removed if necessary. Starting at upper corner and gradually working windshield into position is recommended.

NOTE

Screws and self-locking nuts may be used instead of rivets which fasten front retaining strip to cowl deck. If at least No. 6 screws are used, no loss of strength will result.

3-12. WINDOWS.

3-13. MOVABLE. (Refer to figure 3-3.) Movable windows, hinged at the top are installed in the cabin doors.

3-14. REMOVAL AND INSTALLATION.

- a. Disconnect window stop (4).
- b. Remove pins from window hinges (8).
- c. Reverse preceding steps for installation. To remove frame from plastic panel, drill out blind rivets at frame splice. When replacing plastic panel in frame, ensure sealing strip and an adequate coating of Presstite No. 579.6 sealing compound is used around all edges of panel. Refer to Section 19 before painting the inside of the window frame.

3-15. WRAP-AROUND REAR. (Refer to figure 3-2.) The rear window is a one-piece acrylic plastic panel set in sealing strips and held in place by retaining strips.

3-16. REMOVAL AND INSTALLATION.

- a. Remove upholstery as necessary to expose retainer strips inside cabin.
- b. Remove external centerstrip (9).
- c. Drill out rivets to remove outer retainer (5).

d. Remove window by lifting aft edge and pulling window aft. If difficulty is encountered, rivets securing inner retainers (3) may also be drilled out and retainers loosened or removed as necessary.

e. Reverse preceding steps for installation. Apply sealing strips and an adequate coating of sealing compound to prevent leaks. When installing a new window, use care not to crack panel and file or grind away excess plastic.

3-17. OVERHEAD. (Refer to figure 3-2.) Overhead cabin windows, located in the cabin top, may be installed. These windows are one-piece acrylic plastic panels set in sealing strips and held in place by retaining strips.

3-18. REMOVAL AND INSTALLATION.

- a. Remove headliner and trim panels.
- b. Drill out rivets as necessary to remove retainer strips.
- c. Reverse preceding steps for installation. Apply sealing strips and an adequate coating of sealing compound to prevent leaks. When installing a new window, use care not to crack panel and file or grind away excess plastic.

3-19. CABIN DOORS. (Refer to figure 3-3.)

3-20. REMOVAL AND INSTALLATION. On models except A150-Series, removal of cabin doors is accomplished by removing the screws which attach the hinges or by removing the hinge pins. If the permanent hinge pins are removed from door hinges, they may be replaced by clevis pins secured with cotter pins or new pins may be installed and "spin-bradded." On A150-Series, the hinge pins are of the jettisonable type, which may be removed by pulling the emergency door release. On all 150-Series aircraft, when fitting a new door, some trimming and reforming of the door skin and door edges may be necessary to achieve a good fit.

3-21. ADJUSTMENT. Cabin doors should be adjusted so skin fairs with fuselage skin. Slots at latch plate permit re-positioning of striker plate. Depth of latch engagement may be changed by adding or removing washers or shims between striker plate and doorpost.

3-22. WEATHERSTRIP. A weatherstrip is cemented around all edges of door. New weatherstrip may be applied after mating surfaces of weatherstrip and door are clean, dry and free from oil or grease. Apply a thin, even coat of adhesive to each surface and allow to dry until tacky before pressing strip in place. Minnesota Mining and Manufacturing Co. No. EC880 cement is recommended.

3-23. WEDGE ADJUSTMENT. Wedges at upper forward edge of door aid in preventing air leaks at this point. They engage as door is closed. Several attaching holes are located in wedges and holes which gives best results should be selected.

NOTE

Condition of cabin door hinges should be inspected at 1500 hours to prevent hinge failure.

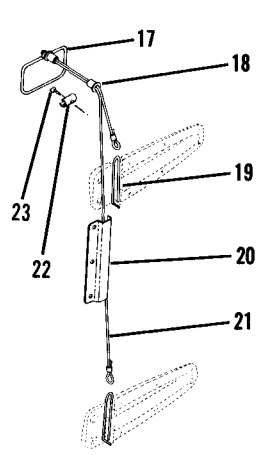
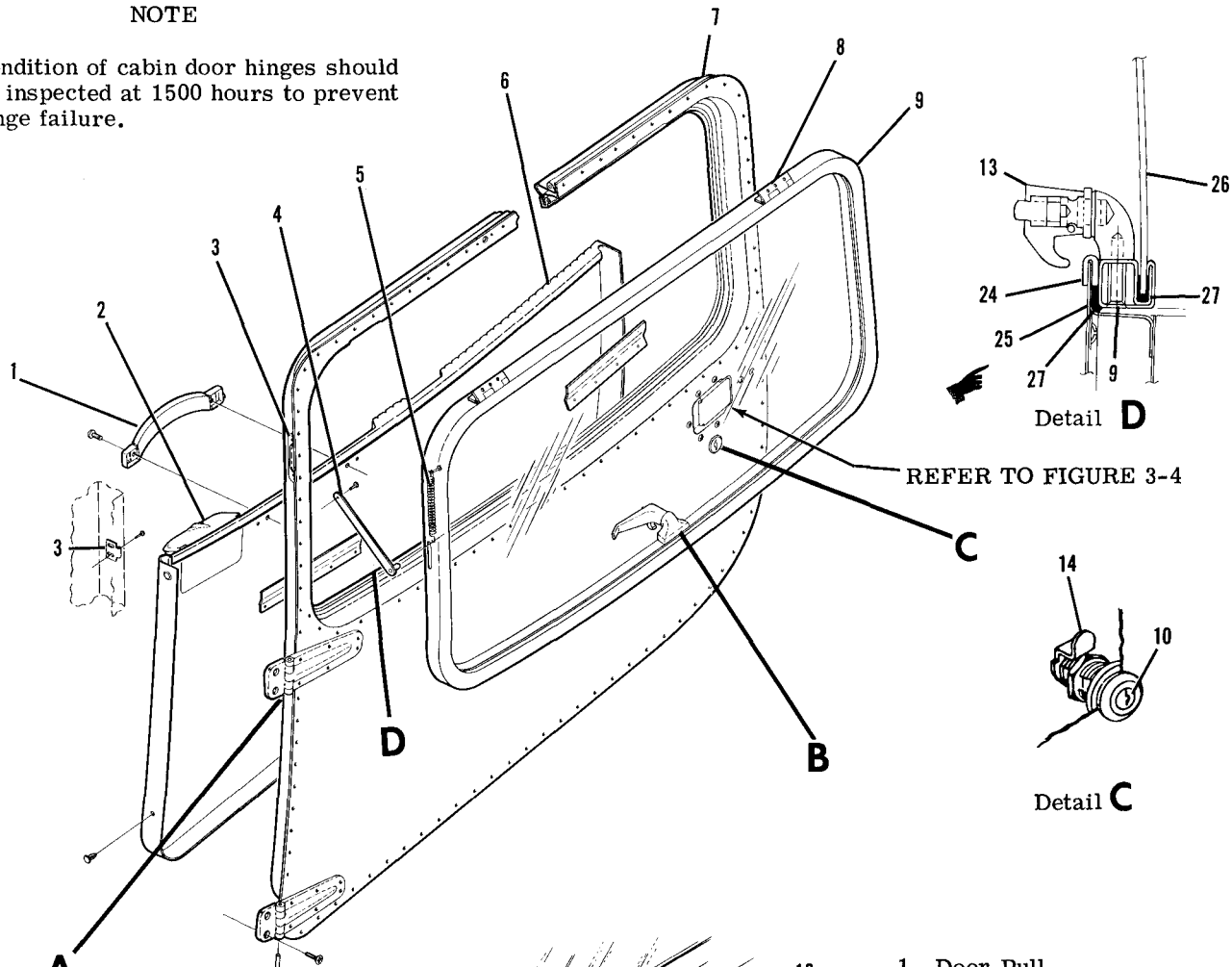

A150-SERIES ONLY

Detail A

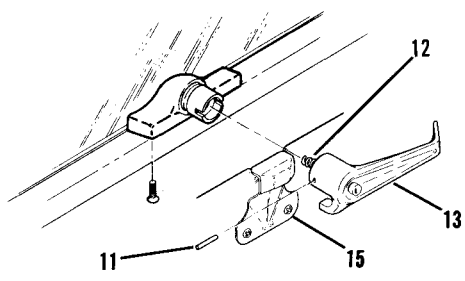

ROTATED 180°

Detail B

1. Door Pull
2. Ash Tray
3. Wedge
4. Window Stop
5. Spring
6. Trim Panel
7. Cabin Door
8. Window Hinge
9. Frame
10. Lock Assembly
11. Roll Pin
12. Latch Spring
13. Latch Handle
14. Cam
15. Striker Plate
16. Hinge Pin
17. Handle Assembly
18. Grommet
19. Hinge Pin (Removable)
20. Cable Guard
21. Cable
22. Clip
23. Screw
24. Nylon Decorative Seal
25. Door Pan
26. Movable Window
27. Extruded Rubber Seal

NOTE

Cabin door release handle pull should be a maximum of 45 lbs.

Figure 3-3. Cabin Door and Movable Window

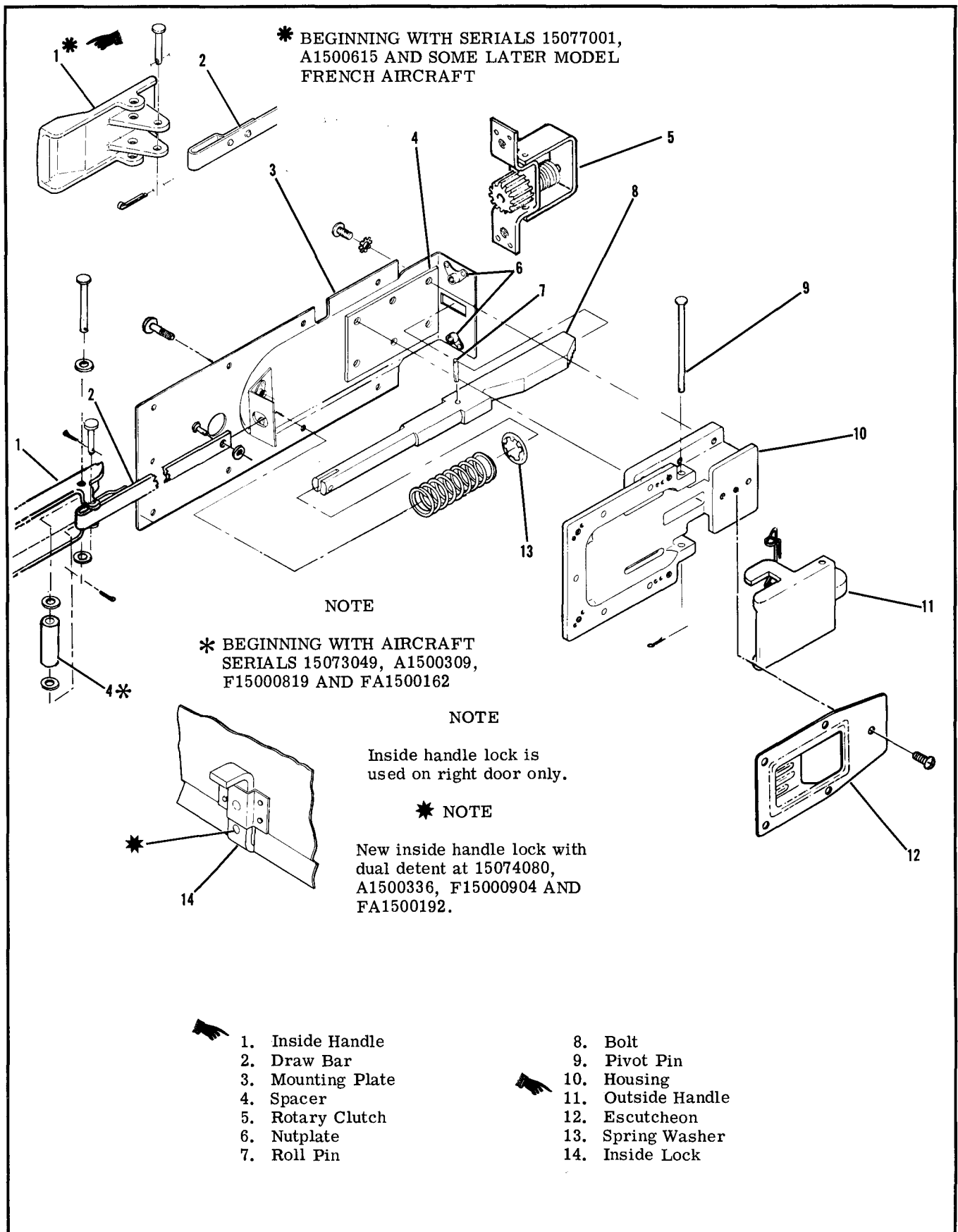

Figure 3-4. Cabin Door Latch

3-24. CABIN DOOR LATCHES. (Refer to figure 3-4.)

3-25 . DESCRIPTION. The cabin door latch utilizes a rotary clutch for positive bolt engagement. As door is closed, teeth on underside of bolt engage gear teeth on clutch. The clutch gear rotates in one direction only and holds door closed. Flush-mounted outside and inside door handles are used to actuate door latches.

3-26. ADJUSTMENT. Adjustment of latch or clutch cover is afforded by oversize and/or slotted holes. This adjustment ensures sufficient gear-to-bolt engagement and proper alignment.

NOTE

Lubricate door latch per Section 2. No lubrication is recommended for rotary clutch.

3-27. LOCK. In addition to an interior lock, a cylinder and key type lock is installed on left door. If lock is to be replaced, the new one may be modified to accept original key. This is desirable, as the same key is used for ignition switch and cabin door lock. After removing old lock from door, proceed as follows:

- a. Remove lock cylinder from new housing.
- b. Insert original key into new cylinder and file off any protruding tumblers flush with cylinder. Without removing key, check that cylinder rotates freely in housing.
- c. Install lock assembly in door and check lock operation with door open.
- d. Destroy new key and disregard code number on cylinder.

3-28. SEATS. (Refer to figure 3-5 and 3-6.)

3-29. PILOT AND COPILOT.

A. ADJUSTABLE BACK/STATIONARY BOTTOM.

B. RECLINING BACK/FORE-AND-AFT ADJUSTABLE BOTTOM.

C. RECLINING BACK/FORE AND AFT AND VERTICALLY ADJUSTABLE BOTTOM.

3-30. DESCRIPTION. The standard pilot and copilot seat is comprised of an adjustable double-width seat back and two stationary single-width seat bottoms thru 1972 models. Beginning with 1973 models the standard and optional seats are individual seats for the pilot and copilot positions. The seats adjust fore and aft on seat rails and the backs are two position adjustable. Beginning with 1976 Models, optional pilot and copilot seats feature a fore and aft adjustment plus a 3 position vertical adjustment.

NOTE

The vertically adjustable seat is spring loaded to the high position and is adjusted upward with no weight on the seat.

Stops are provided to limit the travel on fore and aft adjustable seats.

3-31. REMOVAL AND INSTALLATION.

(Standard seat thru 1972 models).

- a. Unlatch top of seat back, release spring-loaded pins at bottom of seat back and remove from aircraft.
- b. Pivot seat bottoms forward and lift up to free pins from cabin floor.

(Standard and optional seats beginning with 1973).

- c. Remove seat stops from rails.
- d. Slide seat fore-and-aft to disengage seat rollers from rails and lift seat out.
- e. Reverse preceding steps for installation. Ensure all seat stops are reinstalled.

WARNING

It is extremely important that seat stops are installed, since acceleration and deceleration could possibly permit seat to become disengaged from seat rails and create a hazardous situation, especially during take-off and landing.

3-32. AUXILIARY.

3-33. DESCRIPTION. The double-width auxiliary seat is permanently bolted to the cabin structure and offers no adjustment provisions. The seat structure is mounted on hinge brackets with pivot bolts, thus allowing seat to be pivoted upward for more baggage area.

3-34. REMOVAL AND INSTALLATION.

- a. Remove bolts securing seat structure to hinge brackets.
- b. Unsnap seat back from aft cabin wall.
- c. Lift seat out.
- d. Reverse preceding steps for installation.

3-35. REPAIR. Replacement of defective parts is recommended in repair of seats. However, a cracked framework may be welded, provided crack is not in an area of stress concentration (close to a hinge or bearing point). The square-tube framework is 6061 aluminum, heat-treated to a T-6 condition. Use a heliarc weld on these seats, as torch welds will destroy heat-treatment of frame structure.

3-36. CABIN UPHOLSTERY. Due to the wide selection of fabrics, styles and colors, it is impossible to depict each particular type of upholstery. The following paragraphs describe general procedures which will serve as a guide in removal and replacement of upholstery. Major work, if possible, should be done by an experienced mechanic. If work must be done by a mechanic unfamiliar with upholstery practices, the mechanic should make careful notes during removal of each item to facilitate its replacement later.

3-37. MATERIALS AND TOOLS. Materials and tools will vary with job. Scissors for trimming upholstery to size and a dull-bladed putty knife for wedging material beneath retainer strips are the only tools required for most trim work. Use industrial rubber cement to hold soundproofing mats and fabric edges in place. Refer to Section 18 for thermo-plastic repairs.

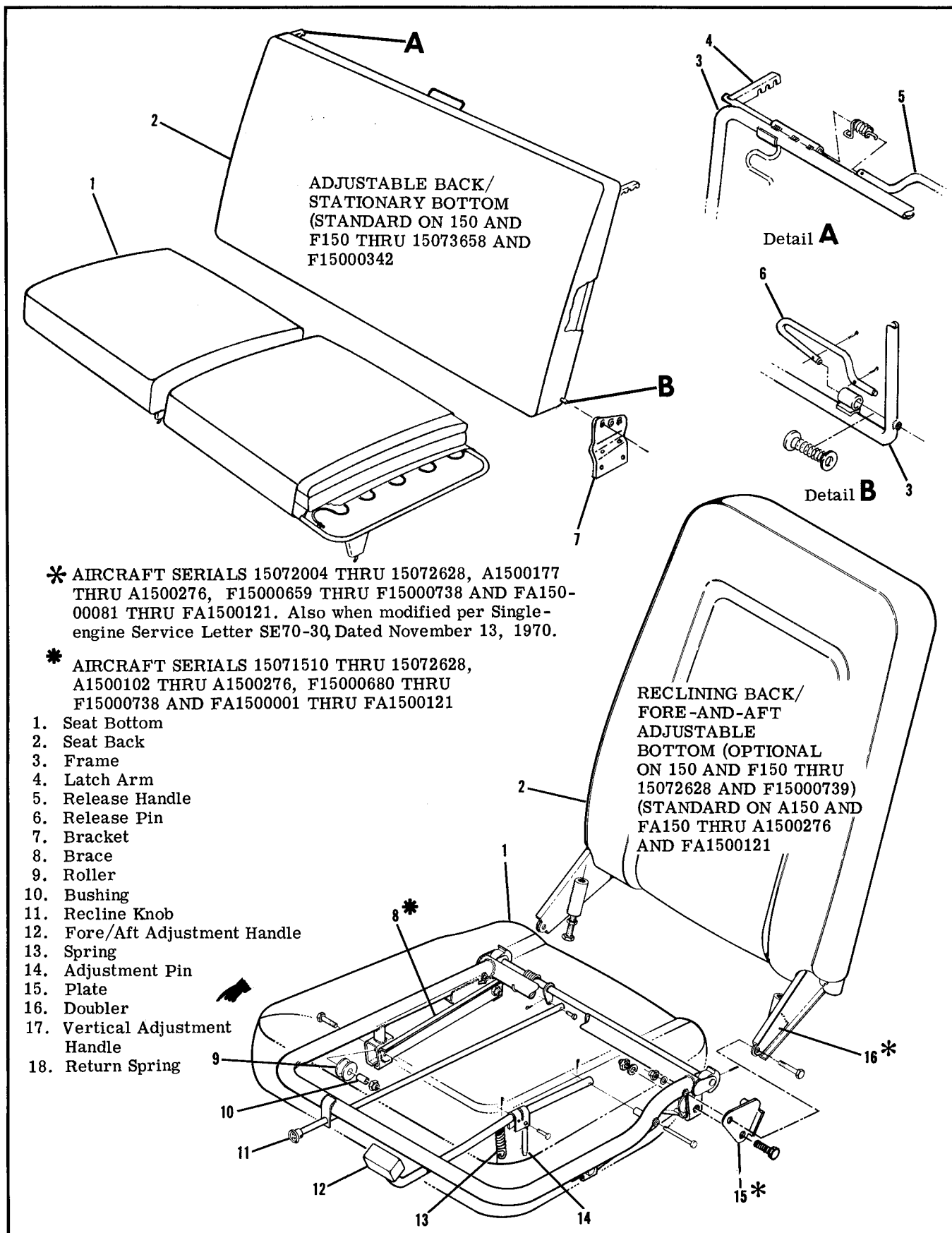
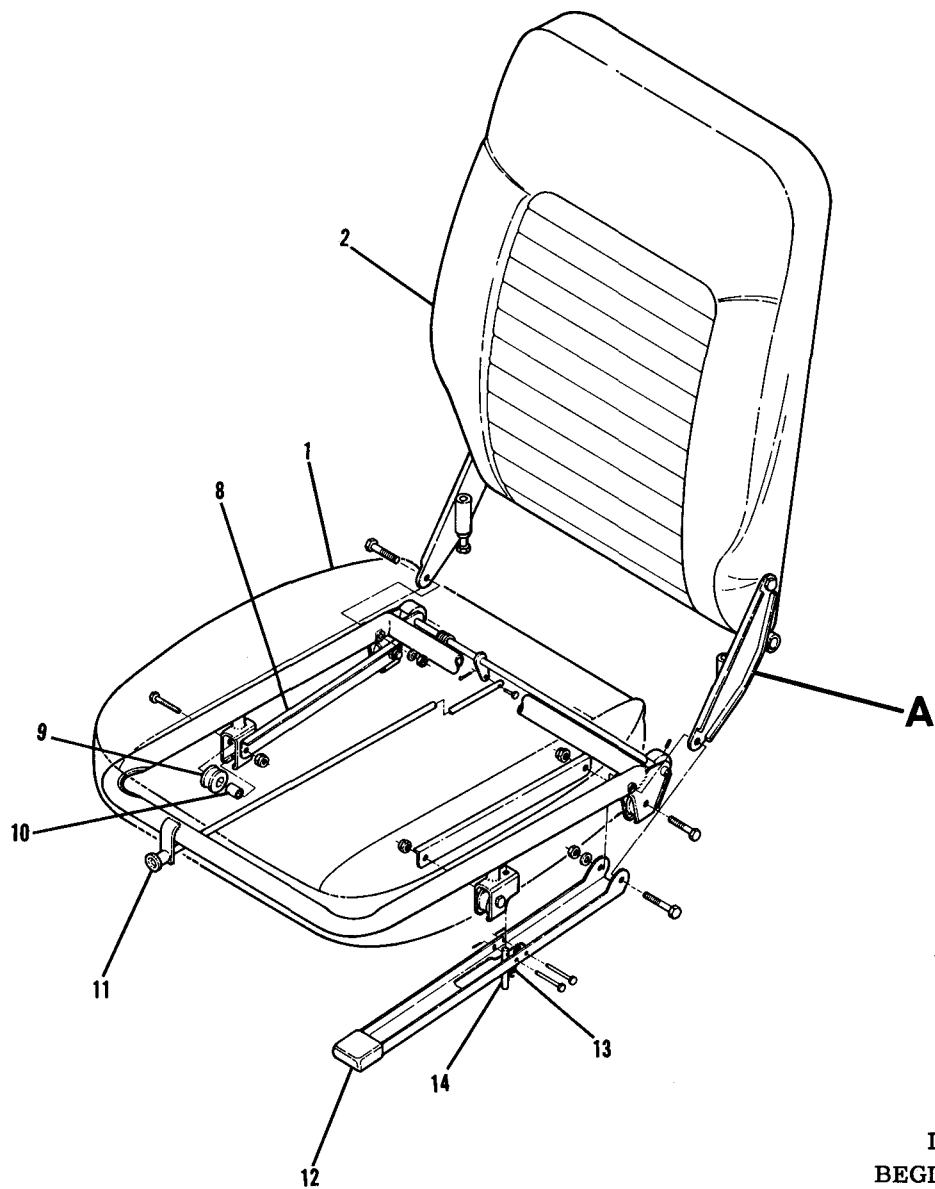

Figure 3-5. Forward Seats (Sheet 1 of 3)



Detail **A**
 BEGINNING WITH
 1973 MODELS.

RECLINING BACK/
 FORE-AND-AFT
 ADJUSTABLE
 BOTTOM (OPTIONAL
 ON 150 AND F150
 15072629 THRU 15073658
 AND F15000739 THRU
 F15000863) (STANDARD
 ON 150, F150, A150 AND
 FA150 BEGINNING WITH
 15073659, F15000864,
 A1500277 AND FA1500122

Figure 3-5. Forward Seats (Sheet 2 of 3)

RECLINING BACK/FORE AND
AFT AND VERTICALLY
ADJUSTABLE BOTTOM
(OPTIONAL BEGINNING WITH
15077001; A1500615; F15001249
AND FA1500282

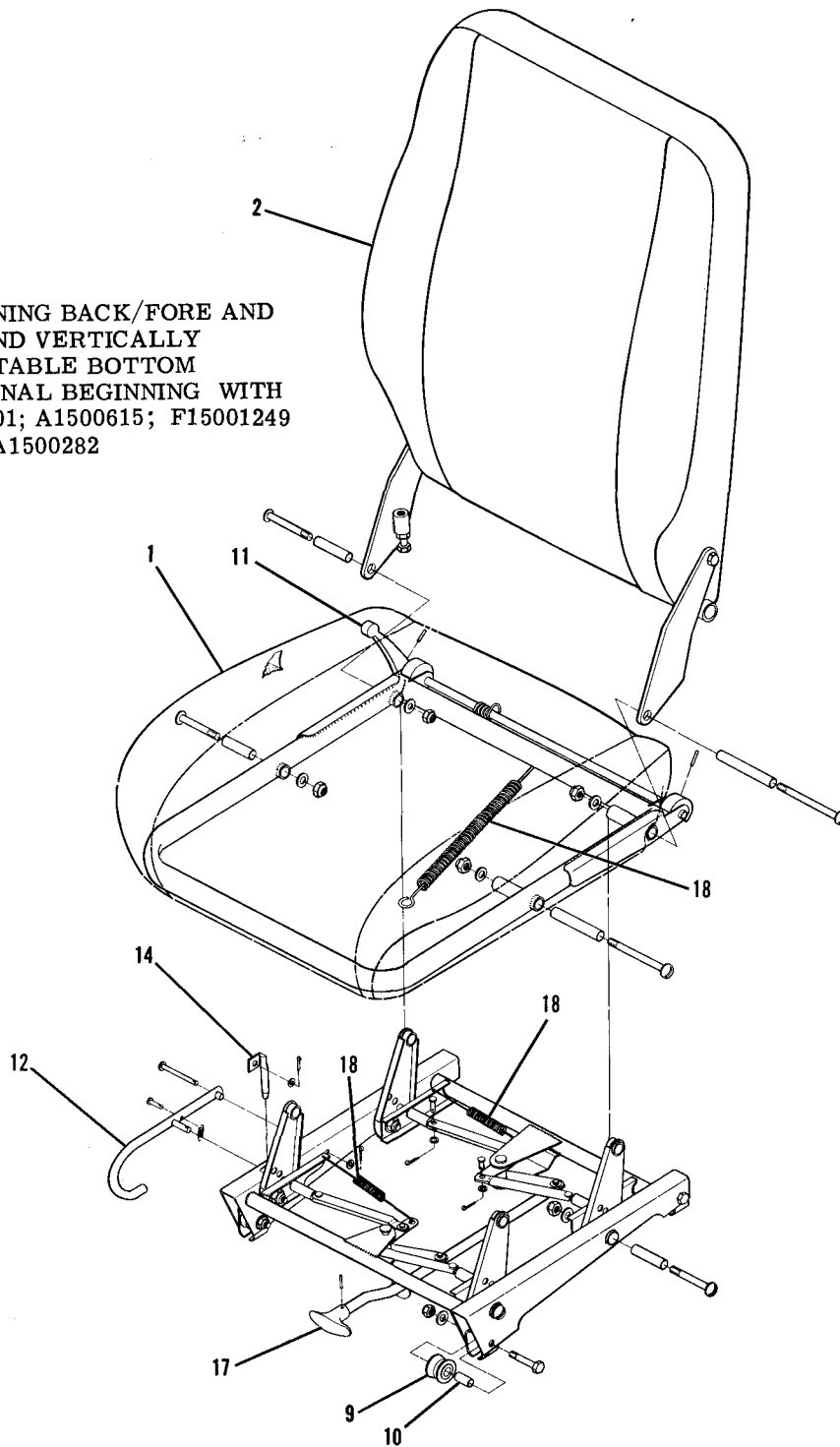

Figure 3-5. Forward Seats (Sheet 3 of 3)

3-38. SOUNDPROOFING. The aircraft is insulated with spun glass mat-type insulation and a sound deadener compound applied to inner surfaces of skin in most areas of cabin and baggage compartment. All

soundproofing material should be replaced in its original position any time it is removed. A soundproofing panel is placed in gap between wing and fuselage and held in place by wing root fairings.

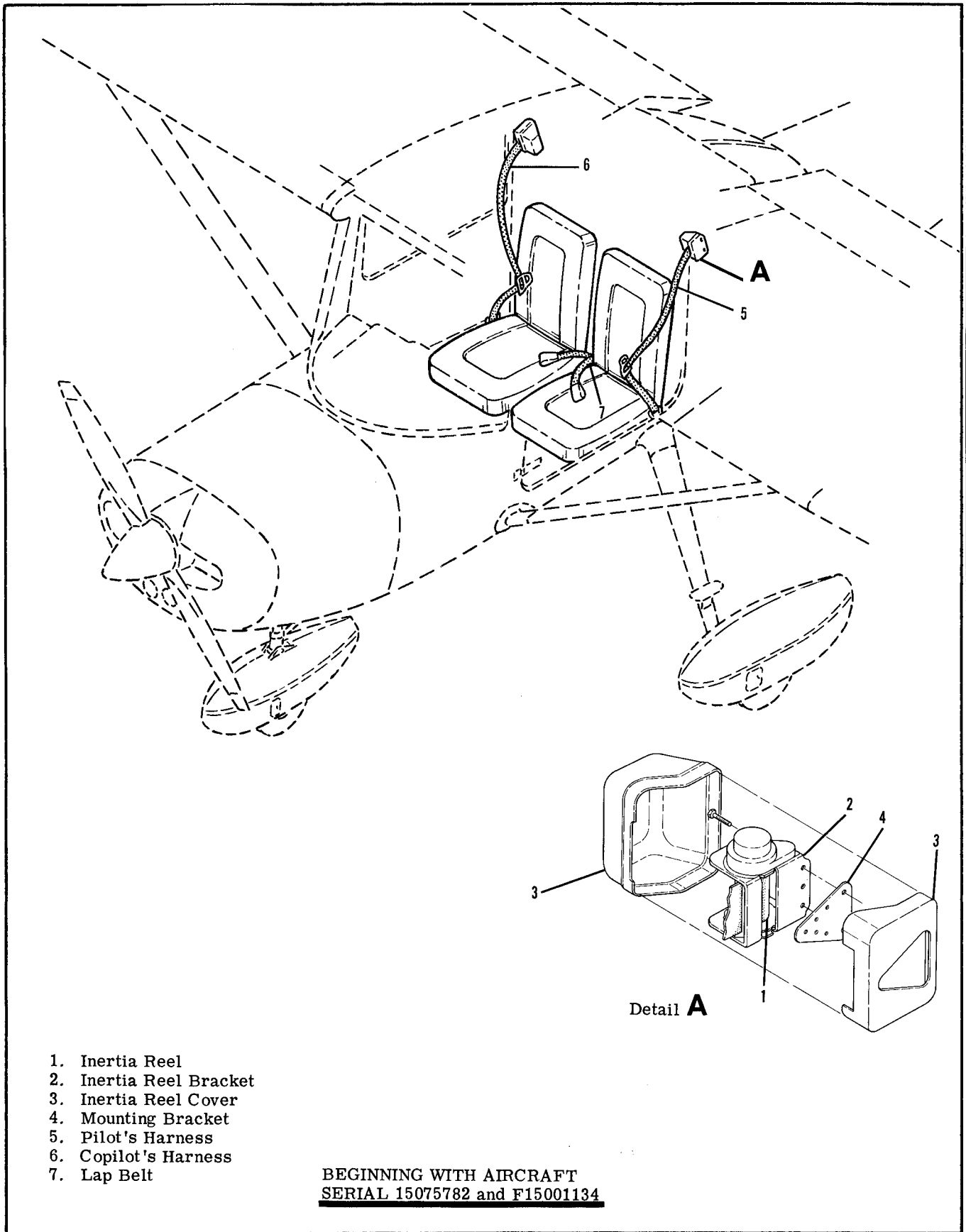

Figure 3-6. Seat Belt and Harness Installation (Sheet 2 of 2)

This page intentionally left blank.

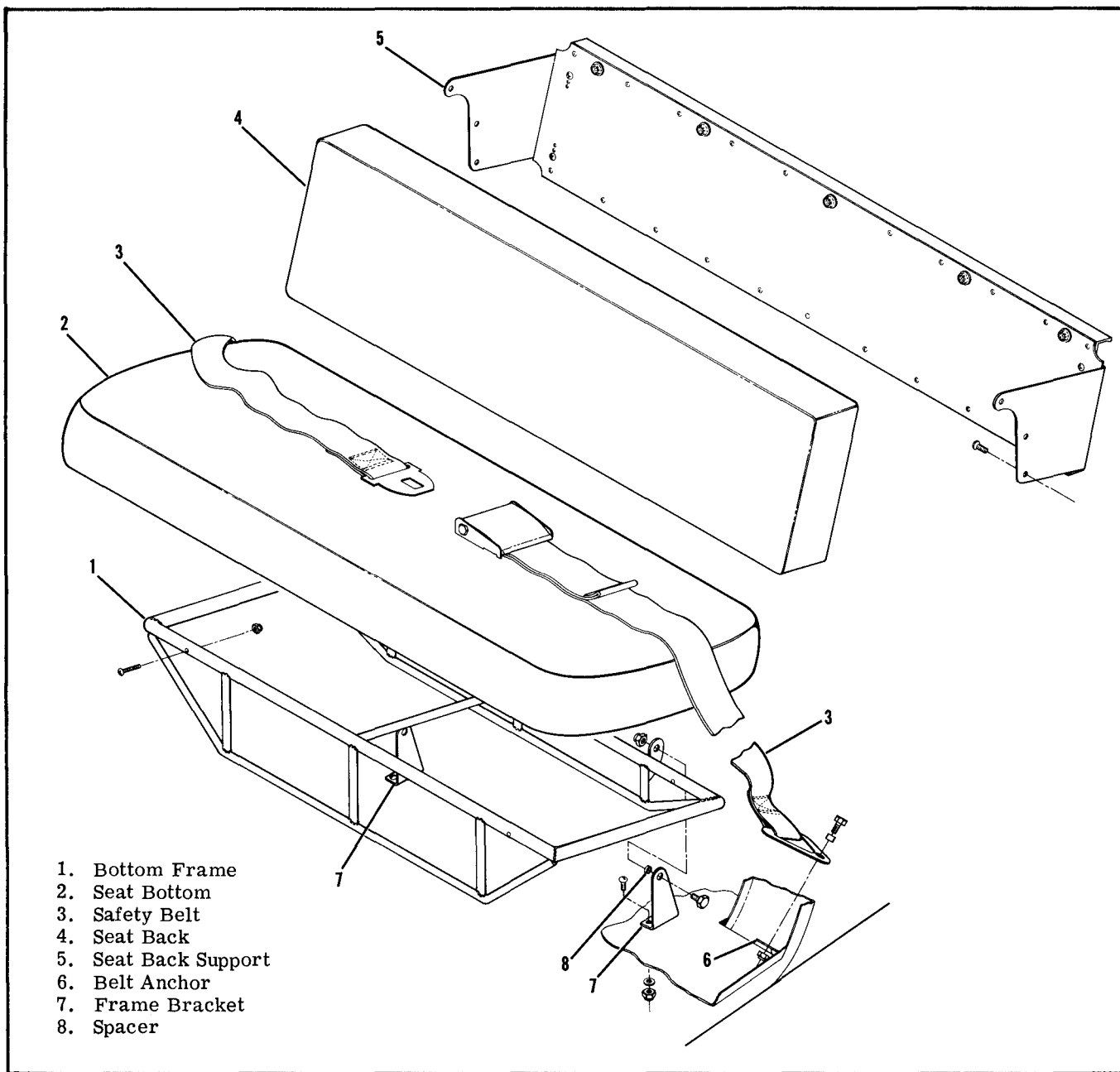

Figure 3-6. Auxiliary Seat

3-39. CABIN HEADLINER. (Refer to figure 3-7)

NOTE

3-40. REMOVAL AND INSTALLATION.

a. Detail A.

1. Remove sun visors, all inside finish strips and plates, doorpost upper shields, front spar trim shield, dome light console and any other visible retainers securing headliner.

2. Work edges of headliner free from metal teeth which hold fabric.

3. Starting at front of headliner, work headliner down, removing screws through metal tabs which hold wire bows to cabin top. Pry loose outer ends of bows from retainers above doors. Detach each wire bow in succession.

Always work from front to rear when removing headliner.

4. Remove headliner assembly and bows from aircraft.

NOTE

Due to difference in length and contour of wire bows, each bow should be tagged to assure proper location in headliner.

5. Remove spun glass soundproofing panels.

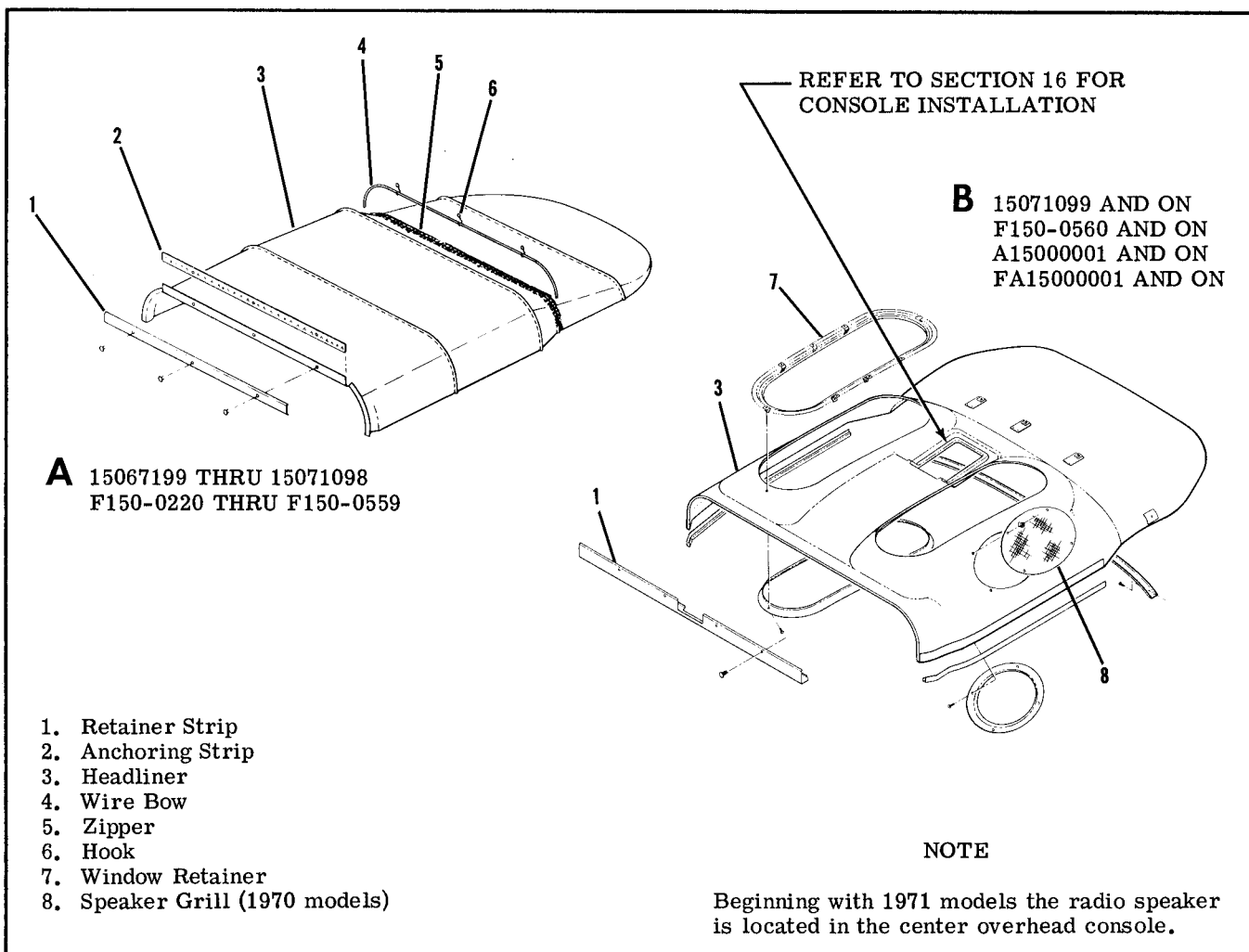

Figure 3-7. Cabin Headliner

NOTE

The lightweight soundproofing panels are held in place with industrial rubber cement.

6. Reverse preceding steps for installation. Before installation, check all items concealed by headliner for security. Use wide cloth tape to secure loose wires to fuselage and to seal openings in wing roots. Straighten tabs bent during removal of headliner.

7. Apply cement to inside of skin in areas where soundproofing panels are not supported by wire bows and press soundproofing in place.

8. Insert wire bows into headliner seams and secure two bows at rear of headliner. Stretch material along edges to properly center, but do not stretch it tight enough to destroy ceiling contours or distort wire bows. Secure edges of headliner with metal teeth.

9. Work headliner forward, installing each wire bow in place with metal tabs. Wedge ends of wire bows into the retainer strips. Stretch headliner just taut enough to avoid wrinkles and maintain a smooth contour.

10. When all bows are in place and fabric edges are secured, trim off excess fabric and reinstall all items removed.

b. Detail B.

1. Remove sun visors, all inside finish strips and plates, overhead console, upper doorpost shields and any other visible retainers securing headliner.

2. Remove molding from fixed windows.

3. Remove screws securing headliner and carefully take down headliner.

4. Remove spun glass soundproofing panels above headliner.

NOTE

The lightweight soundproofing panels are held in place with industrial rubber cement.

5. Reverse preceding steps for installation. Before installation, check all items concealed by headliner for security. Use wide cloth tape to secure loose wires to fuselage and to seal openings in wing roots.

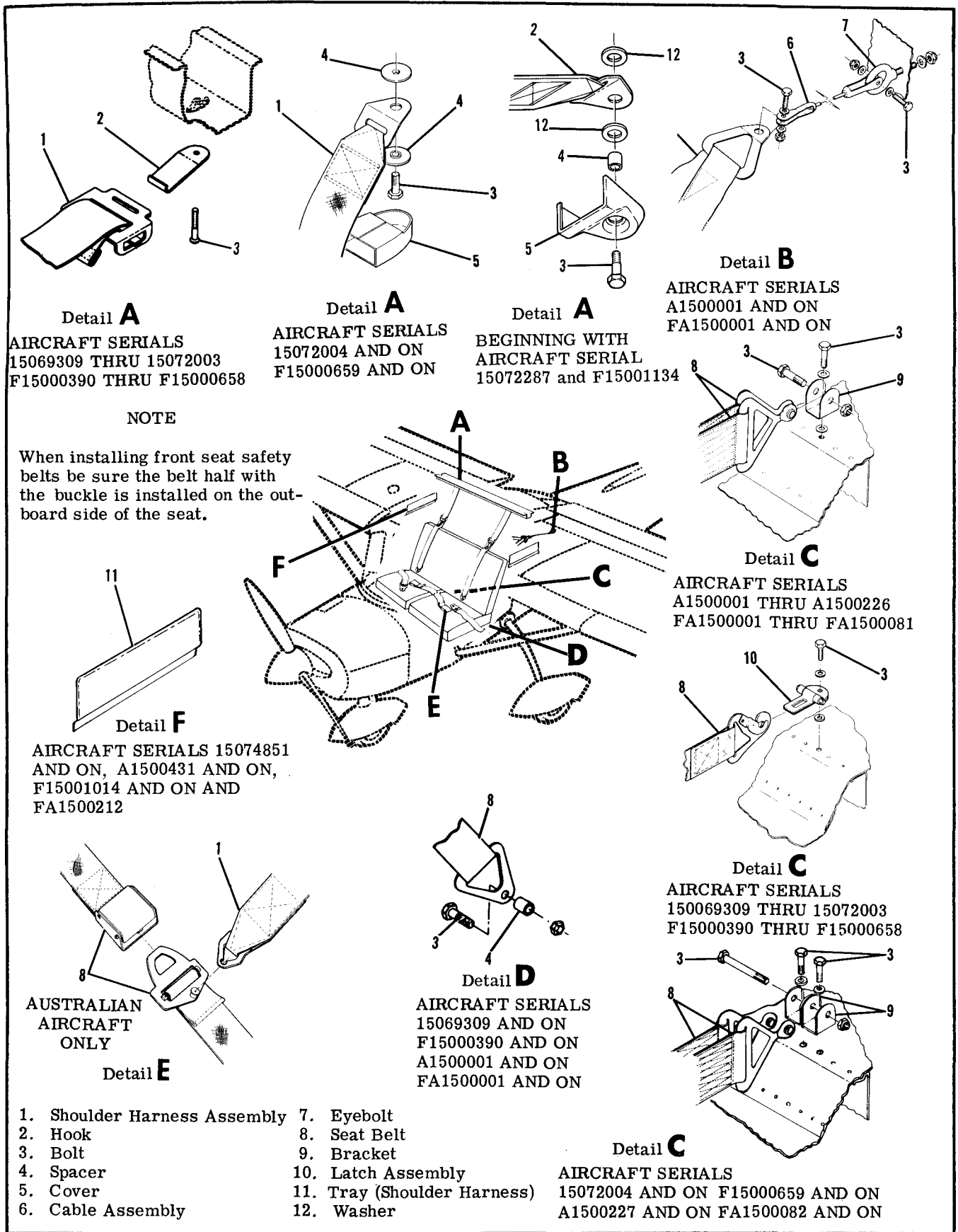

Figure 3-8. Seat and Harness Installation (Sheet 1 of 2)

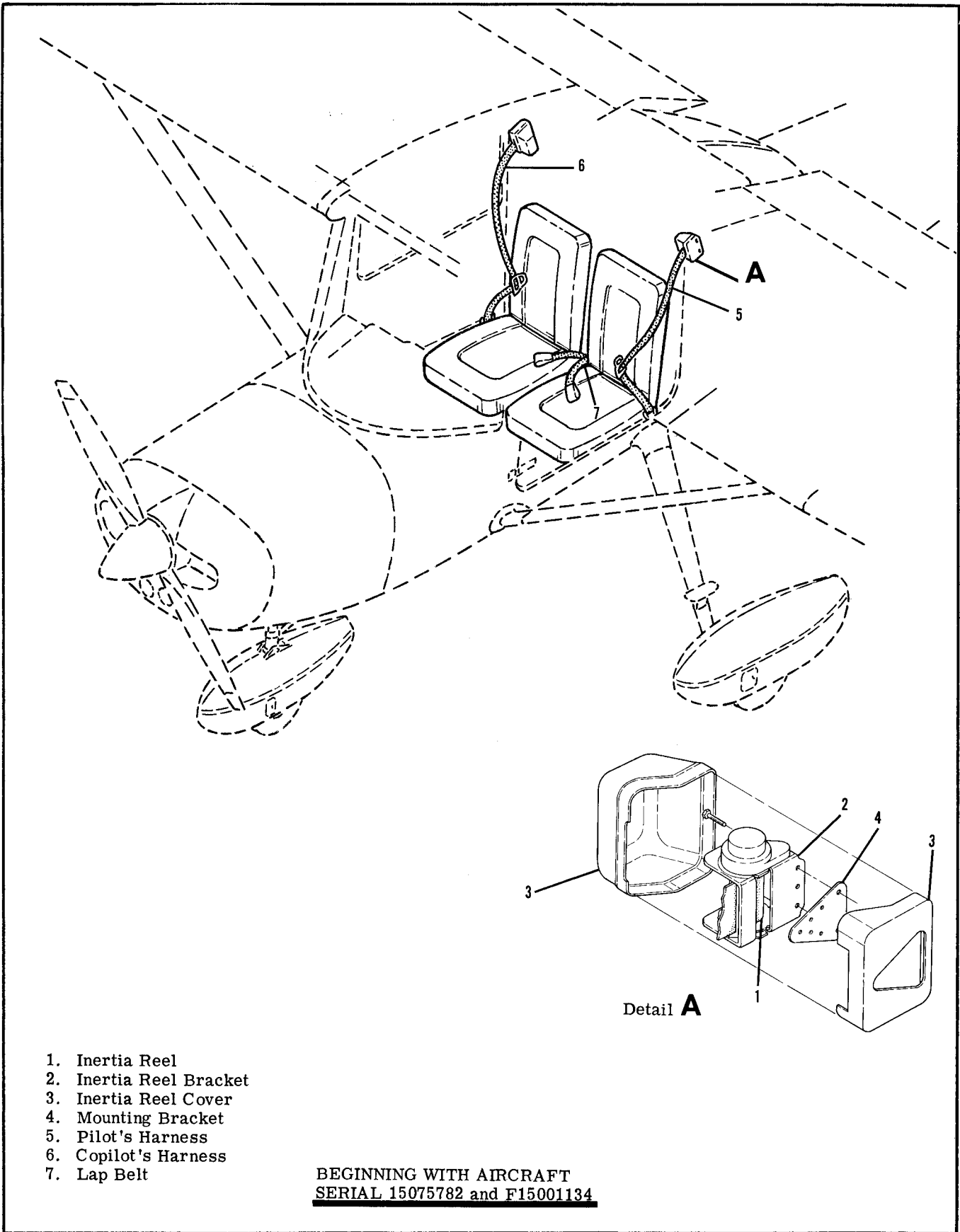

Figure 3-8. Seat Belt and Harness Installation (Sheet 2 of 2)

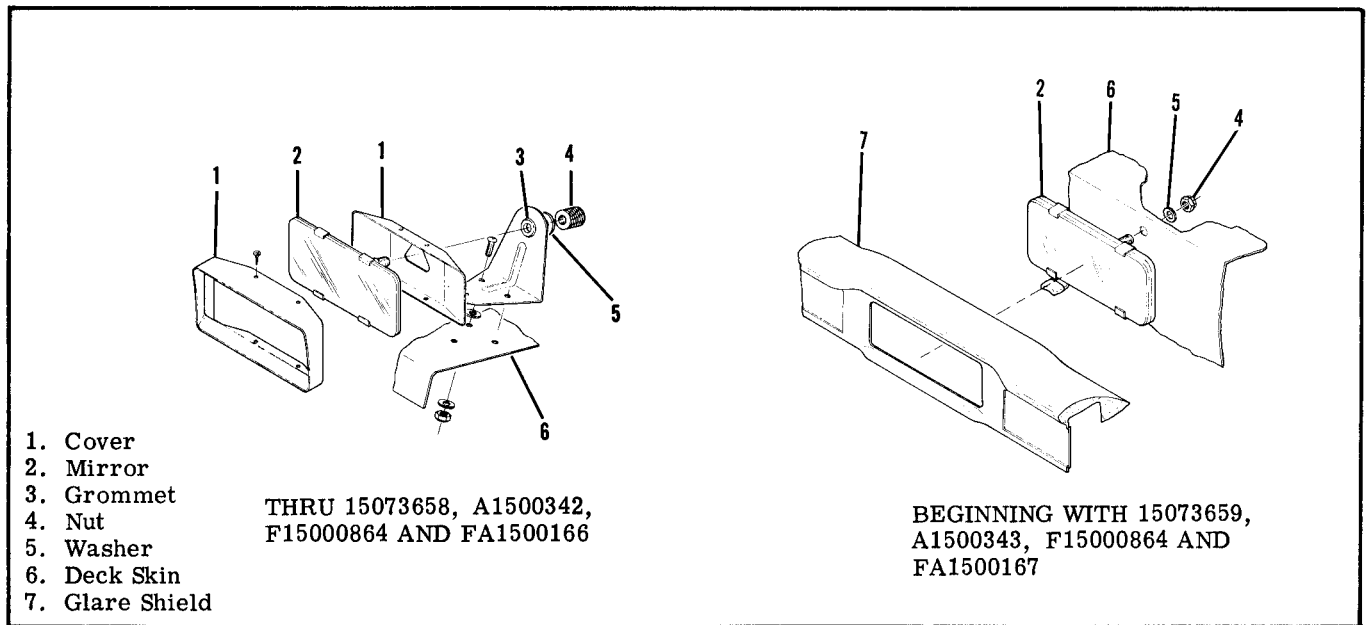

Figure 3-9. Rear View Mirror Installation

3-41. UPHOLSTERY SIDE PANELS. Removal of upholstery side panels is accomplished by removing seats for access, then removing parts attaching panels. Remove screws, retaining strips, arm rests and ash trays as required to free the various panels. Automotive type spring clips attach most door panels. A dull putty knife makes an excellent tool for prying the clips loose. When installing upholstery side panels, do not over-tighten sheet metal screws. Larger screws may be used in enlarged holes as long as the area behind the hole is checked for electrical wiring, fuel lines and other components which might be damaged by using a longer screw.

3-42. CARPETING. Cabin area and baggage compartment carpeting is held in place by rubber cement, sheet metal screws or retaining strips. When fitting a new carpet, use old one as a pattern for trimming and marking screw holes.

3-43. BAGGAGE COMPARTMENT UPHOLSTERY. A washable plastic held in place by screws and retainers is used in the baggage compartment. Cargo tie-down and/or seat belt brackets must be removed as necessary to facilitate upholstery removal.

3-44. SAFETY PROVISIONS.

3-45. CARGO TIE-DOWNS. Cargo tie-downs are

used to ensure baggage cannot enter seating area during flight. A baggage net can be secured to aft cabin wall and cabin floor for baggage security.

3-46. SAFETY BELTS. Safety belts, bolted to the cabin structure are provided for each seat. Belts should be replaced if frayed or cut, latches are defective or stitching is broken. Attaching parts should be replaced if excessively worn or defective. Refer to figure 3-8.

3-47. SHOULDER HARNESS. Shoulder harnesses may be installed in the aircraft. The latches require no lubrication. Component parts should be replaced as outlined in preceding paragraph. Refer to figure 3-8.

3-48. INERTIA REEL SHOULDER HARNESS. Beginning with 15075782 and F15001134 Inertia reel shoulder harnesses may be installed. The inertia reel allows free movement for the seat occupant but will lock when subjected to a sudden load. Proper operation of the reel can be checked by applying a quick jerk to the belt, inertia reel should lock and hold. Figure 3-8 sheet 2 may be used as a guide for removal and installation.

3-48. REAR VIEW MIRROR. A rear view mirror may be installed on the cowl deck above the instrument panel. Figure 3-9 illustrates details and may be used as a guide for removal and installation.

SHOP NOTES:

This page intentionally left blank.

SECTION 4

WINGS AND EMPENNAGE

TABLE OF CONTENTS

	Page		
WINGS AND EMPENNAGE	4-1	Repair	4-3
Wings	4-1	Fin	4-3
Description	4-1	Description	4-3
Removal	4-1	Removal and Installation	4-3
Repair	4-1	Repair	4-3
Installation	4-1	Horizontal Stabilizer	4-3
Adjustment	4-3	Description	4-3
Wing Struts	4-3	Removal and Installation	4-4
Description	4-3	Repair	4-4
Removal and Installation	4-3		

4-1. WINGS AND EMPENNAGE.

4-2. WINGS. (Refer to figure 4-1.)

4-3. DESCRIPTION. Each all-metal wing is a semi-cantilever, semimonocoque type, with two main spars and suitable ribs for the attachment of the skin. Skin panels are riveted to ribs, spars and stringers to complete the structure. An all-metal, piano-hinged aileron, flap and a detachable wing tip are mounted on each wing assembly. A single metal fuel tank is mounted between the wing spars at the inboard end of each wing. The leading edge of the left wing may be equipped with landing and taxi lights (thru 1970 Models). Colored navigation lights are mounted at each wing tip.

4-4. REMOVAL. Wing removal is most easily accomplished if four men are available to handle the wing. Otherwise, the wing should be supported with a sling or maintenance stand when the fastenings are loosened.

- a. Remove wing root fairings and fairing plates.
- b. Remove all wing inspection plates.
- c. Drain fuel from tank of wing being removed.
- d. Disconnect:
 1. Electrical wires at wing root disconnects.
 2. Fuel lines at wing root. (Refer to precautions outlined in paragraph 12-3.
 3. Pitot line (left wing only) at wing root.
 4. Cabin ventilator hose at wing root.
 5. Wing leveler vacuum tube, if installed, at wing root.
- e. Slack off tension on aileron cables by loosening turnbuckles, then disconnect cables at aileron bell-cranks. Disconnect flap cables at turnbuckles above headliner, and pull cables into wing root area.

NOTE

To ease rerouting the cables, a guide wire may be attached to each cable before it is pulled free of the wing. Cable may then be disconnected from the wire. Leave the guide wire routed through the wing; it may be at-

tached again to the cable during reinstallation and used to pull the cable into place.

f. Support wing at outboard end and disconnect strut at wing fitting. Tie the strut up with wire to prevent it from swinging down and straining start-to-fuselage fitting. Loosen lower strut fairing and slide it up the strut, the strut may then be lowered without damage.

NOTE

It is recommended that flap be secured in streamlined position with tape during wing removal to prevent damage, since flap will swing freely.

g. Mark position of wing attachment eccentric bushings (refer to figure 4-1); these bushings are used to rig out "wing heaviness".

h. Remove nuts, washers, bushings and bolts attaching wing spars to fuselage.

NOTE

It may be necessary to rock the wing slightly while pulling attaching bolts, or to use a long drift punch to drive out attaching bolts.

i. Remove wing and lay on padded stand.

4-5. REPAIR. A damaged wing panel may be repaired in accordance with instructions outlined in Section 18. Extensive repairs of wing skin or structure are best accomplished using the wing repair jig, which may be obtained from Cessna. The wing jig serves not only as a holding fixture, making work on the wing easier, but also assures absolute alignment of the repaired wing.

4-6. INSTALLATION.

a. Hold wing in position and install bolts, bushings, washers and nuts attaching wing spars to fuselage

* MINIMUM TORQUE
300 LB INCHES

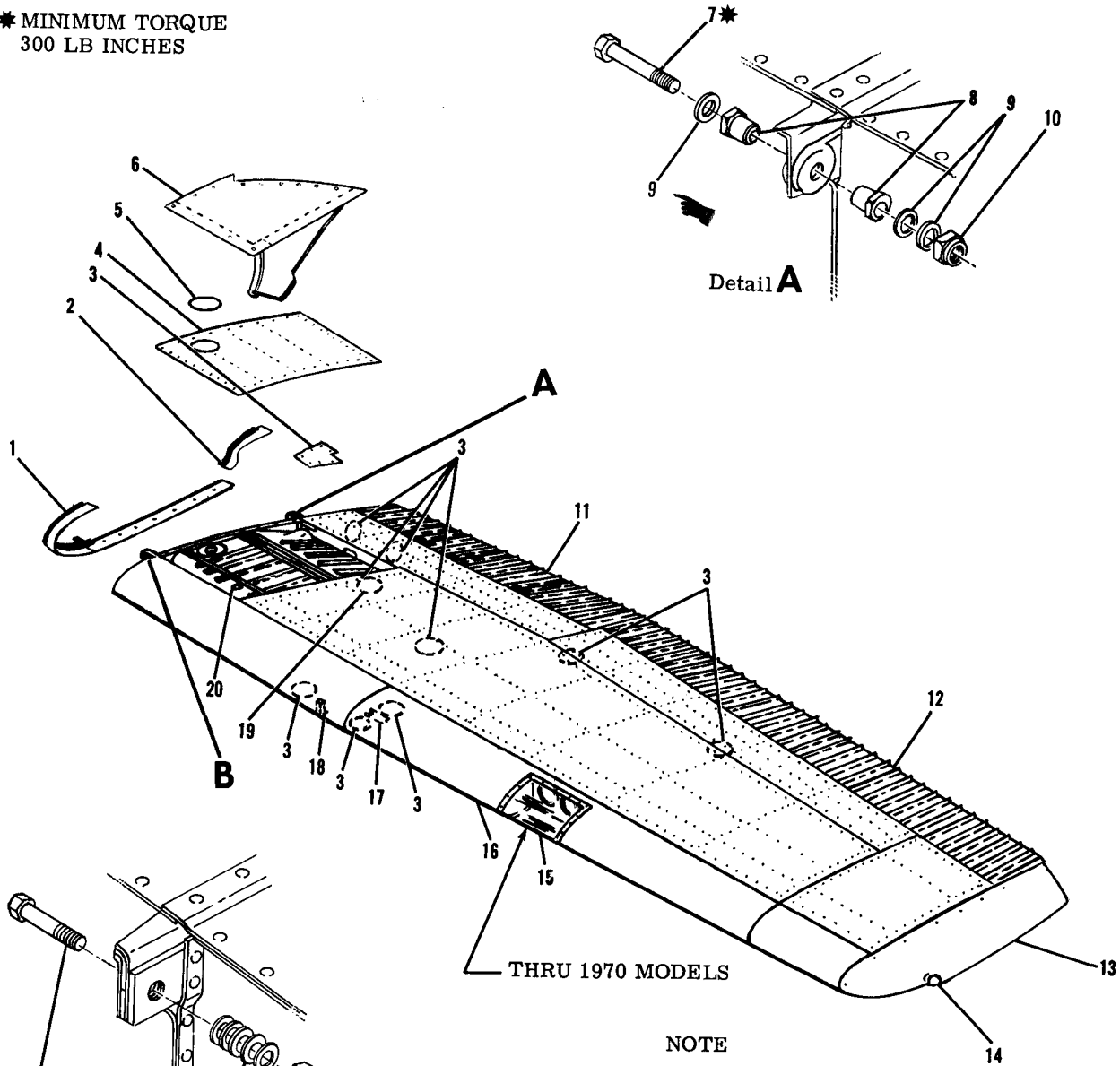

THRU 1970 MODELS

NOTE

Five washers (21) are installed under the nut on the front spar-to-fuselage fitting.

Beginning with the 1971 Models, the landing and taxi lights are located in the nose cowl.

- | | | |
|-----------------------------|-----------------------------|---------------------------|
| 1. Fairing | 8. Eccentric Bushings | 16. Wing Assembly |
| 2. Lower Rear Fairing | 9. Washer | 17. Cover Plate |
| 3. Inspection Plate | 10. Nut | 18. Stall Warning Opening |
| 4. Fuel Tank Cover | 11. Wing Flap | 19. Courtesy Light |
| 5. Fuel Gage Access Cover | 12. Aileron | 20. Fuel Tank |
| 6. Wing-To-Fuselage Fairing | 13. Wing Tip | 21. Washers |
| 7. Bolt | 14. Position Light | 22. Nut |
| | 15. Landing and Taxi Lights | |

Figure 4-1. Wing Installation

fittings. Be sure eccentric bushings are positioned as marked.

b. Install bolts, spacers, and nuts to secure upper and lower ends of wing strut to wing and fuselage fittings.

c. Route flap and aileron cables, using guide wires. (See note in paragraph 4-4.)

d. Connect:

1. Electrical wires at wing root disconnects.

2. Fuel lines at wing root. (Refer to precautions outlined in paragraph 12-3.)

3. Pitot line (if left wing is being installed).

4. Wing leveler vacuum tube, if installed, at wing root.

e. Rig aileron system. (Section 6.)

f. Rig flap system. (Section 7.)

g. Refuel wing tank and check for leaks. (Refer to precautions outlined in paragraph 12-3.)

h. Check operation of wing tip and landing and taxi lights. (thru 1970 Models).

i. Check operation of fuel gage.

j. Install wing root fairings.

NOTE

Beginning with 1972 Models, an extruded fillet sealant (576.1 Permagum: Presstite Engineering Company) of equivalent is applied between cabin top skin and wing skin, also across top of lower strut fitting at skin cutout. Gap between windshield and wing leading edge is sealed with (Polyken 230 or Polyken 231; Kendall-Polyken Division, Tuck 92T, Technical Tape Corporation) or equivalent.

NOTE

Be sure to insert soundproofing panel in wing gap, if such a panel was installed originally, before replacing wing root fairings.

k. Install all wing inspection plates, interior panels and upholstery.

4-7. ADJUSTMENT (CORRECTING "WING-HEAVY" CONDITION. (See figure 4-1.) If considerable control wheel pressure is required to keep the wings level in normal flight, a wing-heavy condition exists.

a. Remove wing fairing strip on the wing-heavy side of the airplane.

b. Loosen nut (10) and rotate bushings (8) simultaneously until the bushings are positioned with the thick side of the eccentrics up. This will lower the trailing edge of the wing, and decrease wing-heaviness by increasing angle-of-incidence of the wing.

CAUTION

Be sure to rotate the eccentric bushings simultaneously. Rotating them separately will destroy the alignment between the off-center bolt holes in the bushings, thus exerting a shearing force on the bolt, with possible damage to the hole in the wing spar.

c. Tighten nut and reinstall fairing strip.

d. Test-fly the aircraft. If the wing-heavy condition

still exists, remove fairing strip on the "lighter" wing, loosen nut and rotate bushings simultaneously until the bushings are positioned with the thick side of the eccentric down. This will raise the trailing edge of the wing, thus increasing wing-heaviness to balance heaviness in the opposite wing.

e. Tighten nut, install fairing strip, and repeat test flight.

4-8. WING STRUTS. (See figure 4-2.)

4-9. DESCRIPTION. Each wing has a single lift strut which transmits a part of the wing load to the lower portion of the fuselage. The strut consists of a streamlined tube riveted to two end fittings for attachment at the fuselage and wing.

4-10. REMOVAL AND INSTALLATION.

a. Remove screws from strut fairings and slide fairings along strut.

b. Remove fuselage and wing inspection plates at strut junction points.

c. Support wing securely, then remove nut and bolt securing strut to fuselage.

d. Remove nut, bolt, and spacer used to attach strut to wing, then remove strut from aircraft.

e. Reverse preceding steps to install strut.

4-11. REPAIR. Wing strut repair is limited to replacement of tie-downs and attaching parts. A badly dented, cracked, or deformed wing strut should be replaced.

4-12. FIN. (See figure 4-3.)

4-13. DESCRIPTION. The fin is primarily of metal construction, consisting of ribs and spars covered with skin. Fin tips are of ABS or glass fiber construction. Hinge brackets at the fin rear spar attach the rudder.

4-14. REMOVAL AND INSTALLATION. A fin may be removed without first removing the rudder. However, for access and ease of handling, the rudder may be removed by following procedures outlined in Section 10.

a. Remove fairings on either side of fin.

b. Disconnect flashing beacon lead, tail navigation light lead, antennas and antenna leads, and rudder cables, if rudder has not been removed.

c. Remove bolts attaching rear fin brackets to horizontal stabilizer.

d. Remove bolts attaching front fin brackets to fuselage; remove fin.

e. Install fin by reversing preceding steps. Be sure to check and reset rudder and elevator travel if any stop bolts were removed or settings disturbed.

4-15. REPAIR. Fin repair should be accomplished in accordance with applicable instructions outlined in Section 18.

4-16. HORIZONTAL STABILIZER. (See figure 4-4.)

4-17. DESCRIPTION. The horizontal stabilizer is primarily of all-metal construction, consisting of ribs and spars covered with skin. Stabilizer tips

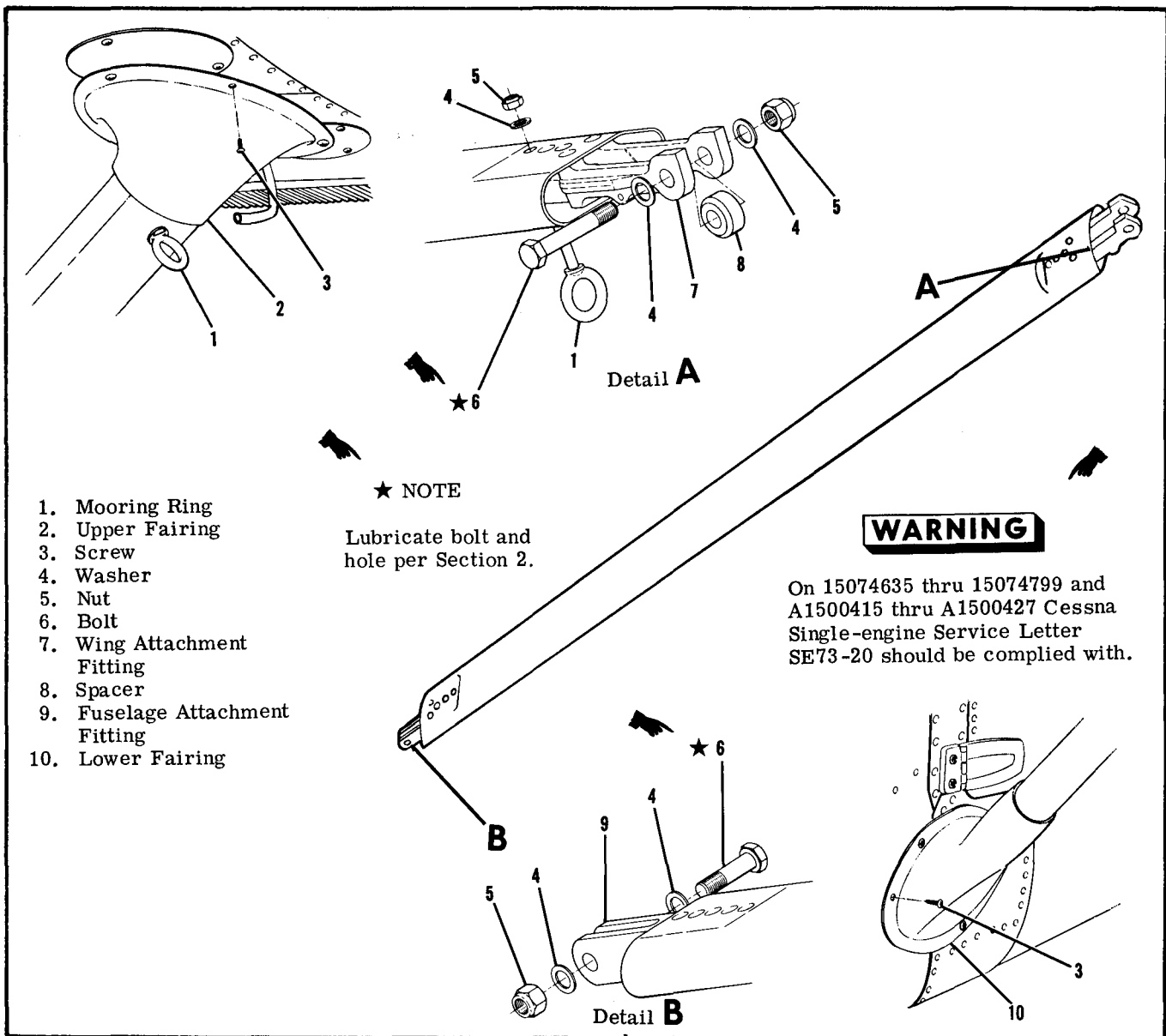

Figure 4-2. Wing Strut

are ABS. A formed metal leading edge is riveted to the assembly to complete the structure. The elevator trim tab actuator is contained within the horizontal stabilizer. The underside of the stabilizer contains a covered opening which provides access to the actuator. Hinges are located on the rear spar assembly to support the elevators.

4-18. REMOVAL AND INSTALLATION.

- a. Remove elevators and rudder in accordance with procedures outlined in Sections 8 and 10.
- b. Remove vertical fin in accordance with procedures outlined in paragraph 4-14.
- c. Disconnect elevator trim control cables at

clevis and turnbuckle inside tailcone, remove pulleys which route the aft cables into horizontal stabilizer, and pull cables out of tailcone.

d. Remove bolts securing horizontal stabilizer to fuselage.

e. Remove horizontal stabilizer.

f. Install horizontal stabilizer by reversing preceding steps. Rig control systems as necessary. Check operation of tail navigation light and flashing beacon.

4-19. REPAIR. Horizontal stabilizer repair should be accomplished in accordance with applicable instructions outlined in Section 18.

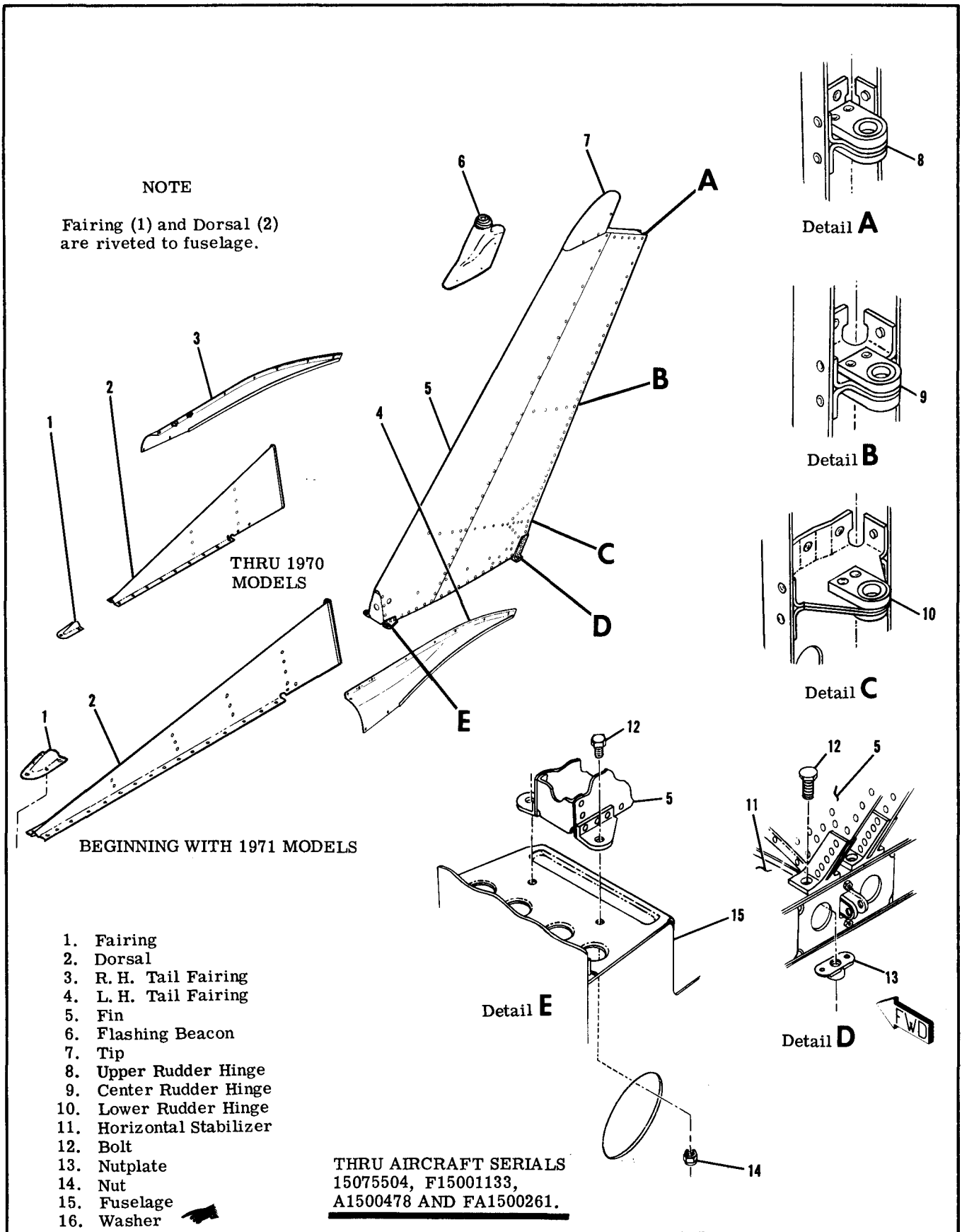

NOTE

Fairing (1) and Dorsal (2) are riveted to fuselage.

THRU 1970 MODELS

BEGINNING WITH 1971 MODELS

- 1. Fairing
- 2. Dorsal
- 3. R. H. Tail Fairing
- 4. L. H. Tail Fairing
- 5. Fin
- 6. Flashing Beacon
- 7. Tip
- 8. Upper Rudder Hinge
- 9. Center Rudder Hinge
- 10. Lower Rudder Hinge
- 11. Horizontal Stabilizer
- 12. Bolt
- 13. Nutplate
- 14. Nut
- 15. Fuselage
- 16. Washer

THRU AIRCRAFT SERIALS
15075504, F15001133,
A1500478 AND FA1500261.

Figure 4-3. Vertical Fin (Sheet 1 of 2)

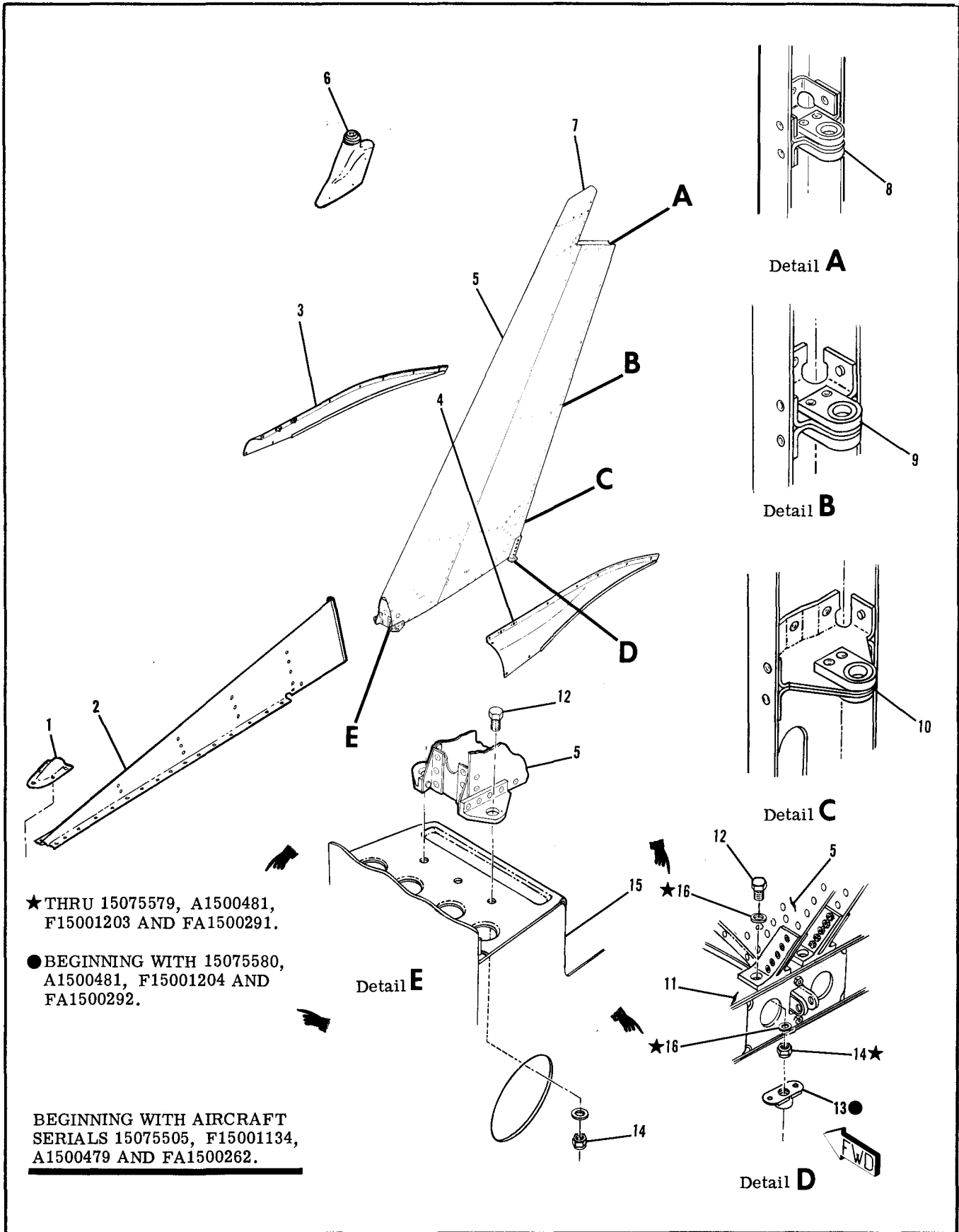

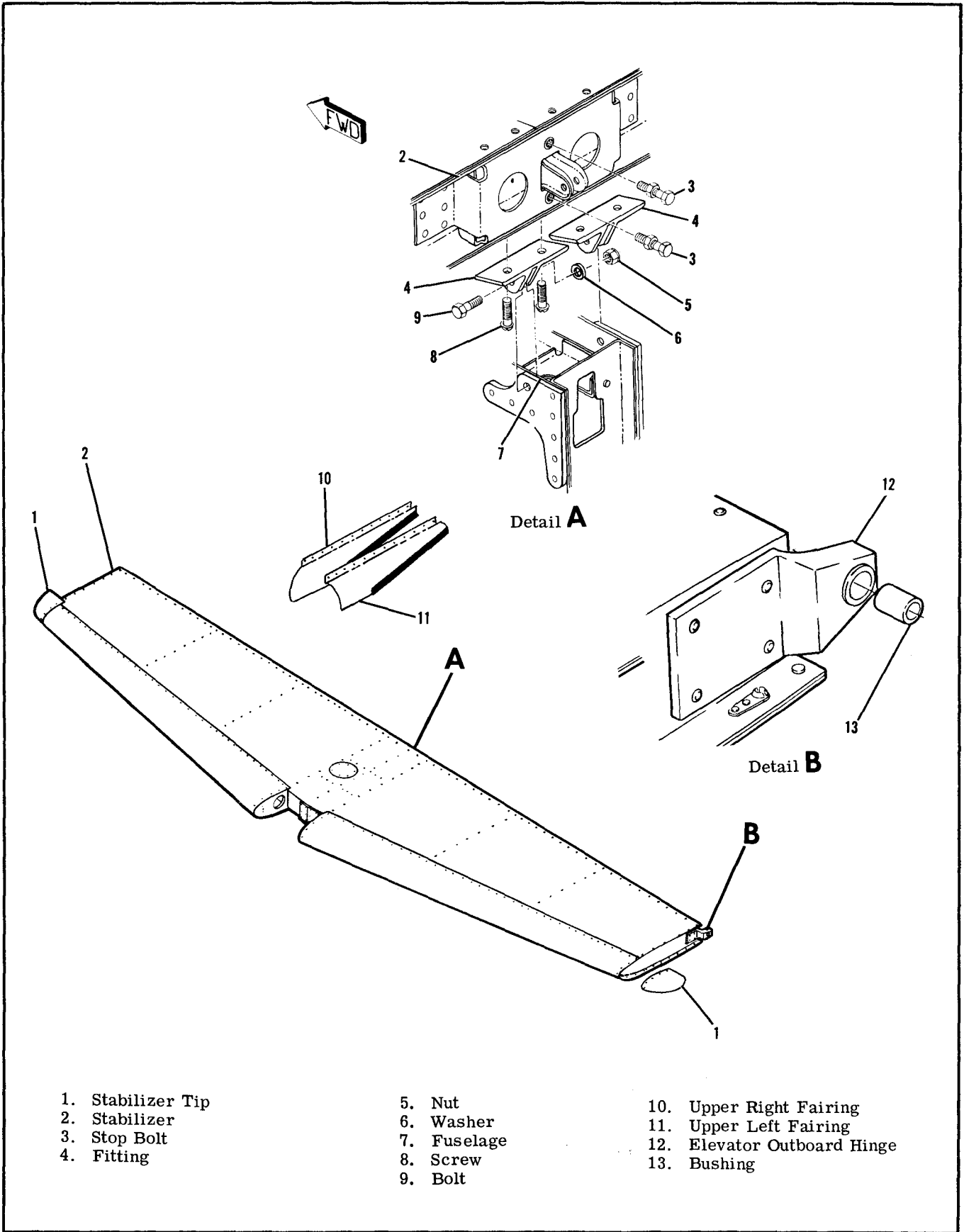

Figure 4-4. Horizontal Stabilizer

This page intentionally left blank.

SECTION 5

LANDING GEAR AND BRAKES

TABLE OF CONTENTS	Page
LANDING GEAR	5-1
General Description	5-1
Trouble Shooting	5-2
Main Gear	5-3
Removal (Flat Gear)	5-3
Installation (Flat Gear)	5-3
Removal (Tubular Gear)	5-6
Installation (Tubular Gear)	5-6
Step Bracket Installation	5-6
Main Wheel Speed Fairing Removal and Installation	5-6
Removal and Installation of Main Landing Gear Fairings	5-8
Main Wheel Removal	5-8A
Disassembly (Cleveland)	5-8A
Inspection and Repair (Cleveland)	5-8A
Reassembly (Cleveland)	5-8A
Disassembly (McCauley)	5-8A
Inspection and Repair (McCauley)	5-8B
Reassembly (McCauley Wheel - Aluminum Flange)	5-8B
Reassembly (McCauley Wheel - Steel Flange)	5-8B
Main Wheel Installation	5-11
Main Wheel Axle Removal (Flat Gear)	5-11
Main Wheel Axle Installation (Flat Gear)	5-11
Main Wheel Axle Removal (Tubular Gear)	5-11
Main Wheel Axle Installation (Tubular Gear)	5-12
Main Wheel Alignment (Flat Gear)	5-12
Main Wheel Alignment (Tubular Gear)	5-13
Wheel Balancing	5-13
Nose Gear	5-13
Trouble Shooting	5-13
Nose Gear Removal and Installation	5-15
Nose Wheel Speed Fairing Removal and Installation	5-15
Nose Wheel Removal and Installation	5-17
Disassembly (Cleveland)	5-17
Inspection and Repair (Cleveland)	5-17
Reassembly (Cleveland)	5-17
Disassembly (McCauley Wheel with thru-bolts)	5-17
Inspection and Repair (McCauley Wheel with thru-bolts)	5-19
Reassembly (McCauley Wheel with thru-bolts)	5-19
Disassembly (McCauley Wheel with Capscrews)	5-19
Inspection and Repair (McCauley Wheel with Capscrews)	5-20
Reassembly (McCauley Wheel with Capscrews)	5-20
Wheel Balancing	5-22
Nose Gear Shock Strut Disassembly	5-22
Nose Gear Shock Strut Reassembly	5-22
Torque Links	5-22
Shimmy Dampener	5-23
Nose Wheel Steering System	5-24
Steering Rod Assembly	5-24
Nose Wheel Steering Adjustment	5-24
BRAKE SYSTEM	5-24
General Description	5-24
Trouble Shooting	5-24
Brake Master Cylinders	5-25
Removal and Installation	5-25
Repair	5-25
Hydraulic Brake Lines	5-25
Wheel Brake Assemblies	5-25
Removal	5-25
Inspection and Repair	5-25
Reassembly	5-25
Installation	5-25
Checking Brake Lining Wear	5-25
Brake Lining Installation	5-25
Brake System Bleeding	5-28
Parking Brake System	5-28

5-1. LANDING GEAR.

5-2. DESCRIPTION. Flat spring-steel main landing gear struts are installed on 1969 thru 1970 model aircraft. This installation is illustrated in figure 5-1, sheet 1. Beginning with 1971 models, tubular spring-steel main gear struts are installed, and are illustrated on sheet 2 of figure 5-1. All models are equipped with air/oil, steerable nose gear shock struts. A bracket to attach a step to each main gear strut is bonded with an epoxy-base adhesive. Wheels with disc-type brakes and tube-type tires are installed.

Brake discs are attached to the wheels with thru-bolts or capscrews, and are an integral part of the wheel. The nose gear is a combination of conventional air/oil (oleo) strut and fork, incorporating a shimmy dampener. The nose wheel is steerable with the rudder pedals up to a maximum pedal deflection, after which it becomes free-swiveling up to a maximum travel of 30 degrees each side of center. Through use of the brakes, the aircraft can be pivoted about the outer wing strut fitting. Nose and main wheel speed fairings are available for installation.

5-3. TROUBLE SHOOTING.

TROUBLE	PROBABLE CAUSE	REMEDY
AIRCRAFT LEANS TO ONE SIDE.	Incorrect tire inflation.	Inflate to pressure specified in figure 1-1.
	Landing gear attaching parts not tight.	Tighten loose parts; replace defective parts with new parts.
	Landing gear spring excessively sprung.	Remove and install new part (s).
	Incorrect shimming at inboard end of spring strut. (Flat Gear)	Install shims as required. Refer to paragraph 5-6 for limitations.
	Bent axles.	Install new part (s).
TIRES WEAR EXCESSIVELY.	Incorrect tire inflation.	Inflate to pressure specified in figure 1-1.
	Main wheels out of alignment. (Flat Gear.)	Align in accordance with paragraph 5-23.
	Main wheels out of alignment. (Tubular Gear)	Remove and install new part (s).
	Landing gear spring excessively sprung.	Remove and install new part (s).
	Incorrect shimming at inboard end of spring. (Flat gear)	Install shims as required. Refer to paragraph 5-6 for limitations.
	Bent axles.	Install new part (s).
	Dragging brakes.	Refer to paragraph 5-46.
	Wheel bearings too tight.	Adjust properly.
	Wheels out of balance.	Correct in accordance with paragraph 5-24.
Loose torque links.	Add shims or install new parts as required.	
WHEEL BOUNCE EVIDENT ON SMOOTH SURFACE.	Out of balance condition.	Refer to paragraph 5-24.

5-4. MAIN LANDING GEAR. Figure 5-1 illustrates the main landing gear, both flat spring and tubular. The illustrations should be used in conjunction with the following procedures during removal and installation of component parts. Disassembly, inspection and repair, and reassembly of the various main wheel configurations are described in separate paragraphs for each configuration. The solid wheels having two wheel halves are manufactured by Cleveland Aircraft Products Co. and webbed wheels having two flanges and a hub are manufactured by McCauley Industrial Corporation. The Cleveland wheels are shown in figure 5-3. The McCauley wheels have either aluminum flanges or steel flanges as shown in figure 5-3A. The aluminum flanges are attached to the wheel hub by thru-bolts and nuts as shown in figure 5-3A and the steel flanges are attached to the wheel hub by cap-screws as shown in figure 5-3A. During assembly of the main wheels the thru-bolt nuts or capscrews, as applicable, shall be tightened evenly and torqued to the value specified in figure 5-2A.

- 5-5. REMOVAL (FLAT.) (See sheet 1 of figure 5-1.) The following procedural steps remove the landing gear as a complete assembly. Refer to applicable paragraphs for removal of the individual components.
- a. Remove floorboard access covers over spring-strut being removed.
 - b. Hoist or jack aircraft in accordance with Section 2.
 - c. Remove screws and allow external fairing plate and seal to slide down spring-strut.

- d. Drain hydraulic brake fluid from brake line on strut being removed.
- e. Disconnect hydraulic brake line at fitting where brake line comes through fuselage skin. Cap or plug disconnected fittings.
- f. Remove bolt attaching wedge at outboard landing gear fitting and pry wedge and shims out of fuselage. Retain shims and wedge.
- g. Remove bolt attaching inboard end of the strut to the inboard fitting and pull entire gear assembly out of fuselage. Note shim(s) placed under inboard end of strut and mark them to be sure they are installed correctly at installation of strut.

5-6. INSTALLATION (FLAT.) (See sheet 1 of figure 5-1.) The following procedural steps install the landing gear as a complete assembly. Refer to applicable paragraphs for installation of the individual components.

- a. Slide external fairing plate and seal over upper end of landing gear spring-strut.

NOTE

Shims are installed under inboard end of the spring-strut as required to level the wings within a total tolerance of three inches. Maximum number of shims permissible is three.

- b. Slide spring strut into place and work shims in position under inboard end of strut. Install bolt to secure inboard end of strut.

SHOP NOTES:

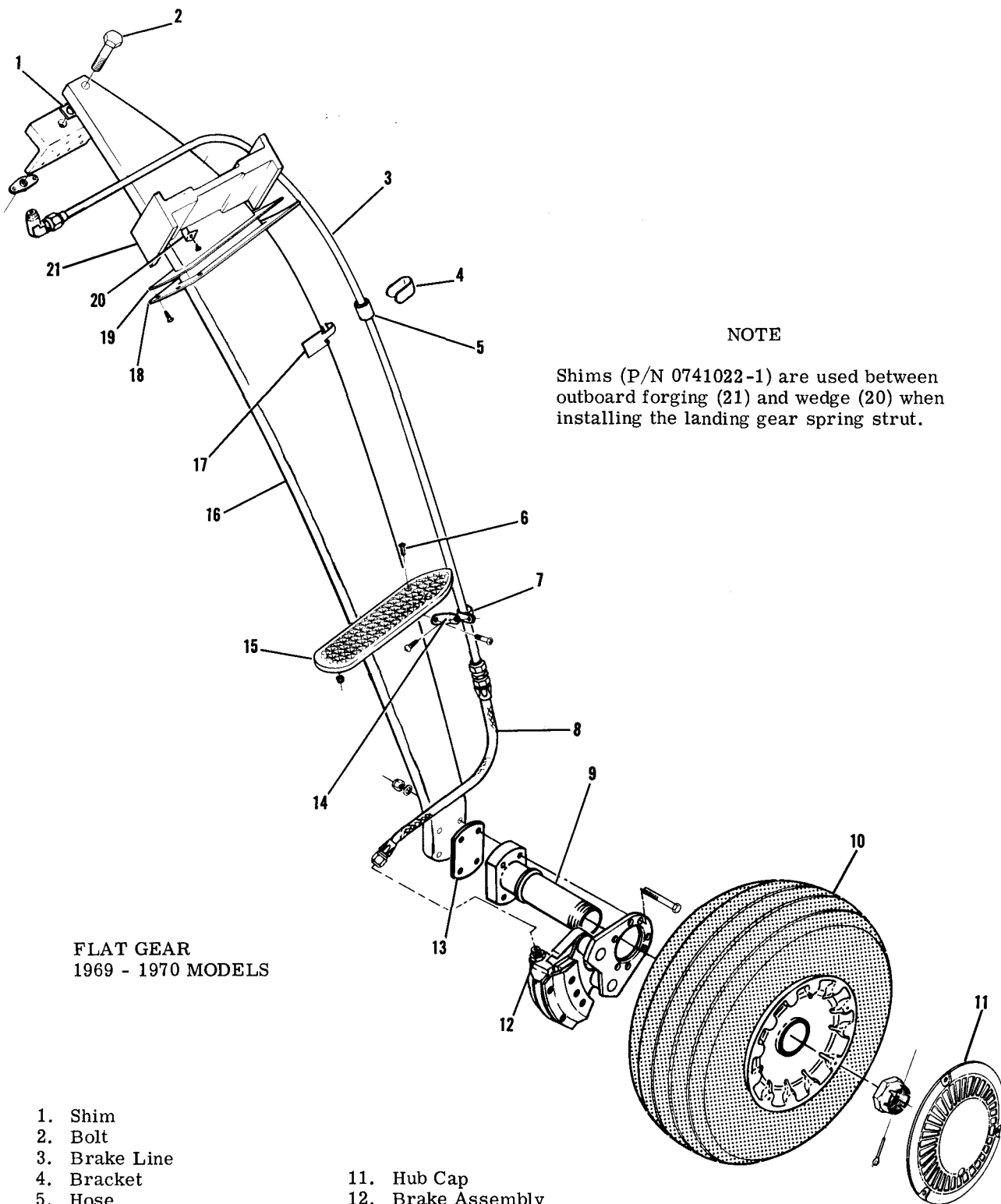

NOTE

Shims (P/N 0741022-1) are used between outboard forging (21) and wedge (20) when installing the landing gear spring strut.

FLAT GEAR
1969 - 1970 MODELS

- | | | |
|--------------------|--------------------|----------------------|
| 1. Shim | 11. Hub Cap | 18. Fillet Plate |
| 2. Bolt | 12. Brake Assembly | 19. Seal |
| 3. Brake Line | 13. Shim | 20. Wedge |
| 4. Bracket | 14. Bracket | 21. Outboard Forging |
| 5. Hose | 15. Step | |
| 6. Screw | 16. Spring Strut | |
| 7. Clamp | 17. Bracket | |
| 8. Brake Hose | | |
| 9. Axle | | |
| 10. Wheel Assembly | | |

Figure 5-1. Main Landing Gear (Sheet 1 of 2)

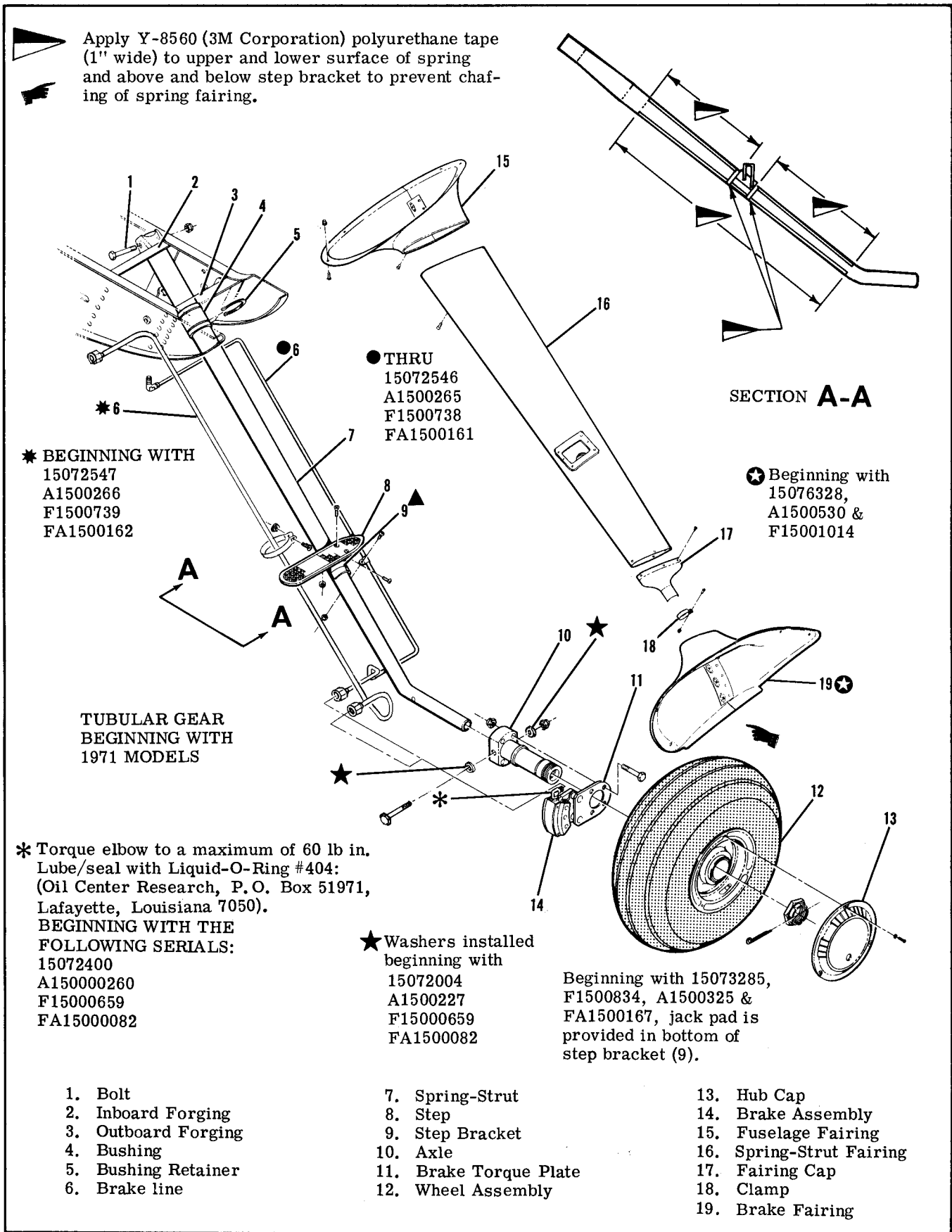

Figure 5-1. Main Landing Gear (Sheet 2 of 2)

- c. Position wedge and shims at outboard landing gear fitting and tap securely in place and install wedge attaching bolt. Avoid excessive pounding of wedges to prevent deforming supporting structure.
- d. Install seal and external fairing plate with attaching screws.
- e. Connect hydraulic brake line, and fill and bleed brakes as outlined in paragraph 5-58.
- f. Install floorboard access covers.
- g. Lower aircraft.

5-7. REMOVAL. (TUBULAR.) (See sheet 2 of figure 5-1.) The following procedural steps remove the landing gear as a complete assembly. Refer to applicable paragraphs for removal of the individual components.

- a. Remove floorboard access covers over spring-strut being removed.
- b. Hoist or jack aircraft in accordance with Section 2.
- c. Remove screws attaching fairing and allow fairing to slide down spring-strut.
- d. Drain hydraulic brake fluid from brake line on strut being removed.
- e. Disconnect hydraulic brake line at fitting where brake line comes through fuselage skin. Cap or plug disconnected fittings.
- f. Remove nut, washer, and bolt attaching inboard end of spring-strut to the inboard landing gear bulkhead fitting.
- g. Pull spring-strut from fitting and bushing. Use care when removing spring-strut to prevent damage to the hydraulic brake line. The spring-strut is a compression fit in the bushing in the outboard landing gear bulkhead.

5-8. INSTALLATION (TUBULAR.) (See sheet 2 of figure 5-1.) The following steps install the landing gear as a complete assembly. Refer to applicable paragraphs for installation of the individual components.

- a. Re-install all parts removed from strut.
- b. Apply Dow Corning Compound DC7 to approximately 11 inches on upper end of spring-strut.
- c. Slide spring-strut into place through bushing in outboard spring-strut fitting and into spring-strut inboard fitting.
- d. Align spring-strut in inboard fitting and install bolt through fitting and spring-strut. Install washer and nut on bolt and tighten to torque value listed in Section 1.
- e. Connect hydraulic brake line to fitting. Fill and bleed brake system in accordance with paragraph 5-58.
- f. Install fairing.
- g. Lower aircraft and install floorboard access covers.

5-9. STEP BRACKET INSTALLATION.

NOTE

The step bracket is secured to the landing gear spring strut with EA9309, or a similar epoxy base adhesive.

- a. Mark position of the bracket so that the new step bracket will be installed in approximately the same position on the strut.
- b. Remove all traces of the original bracket and adhesive as well as any rust, paint, or scale with a wire brush and coarse sandpaper.
- c. Leave surfaces slightly roughened or abraded, but deep scratches or nicks should be avoided.
- d. Clean surfaces to be bonded together thoroughly. If a solvent is used, remove all traces of the solvent with a clean, dry cloth. It is important that the bonding surfaces be clean and dry.
- e. Check fit of the step bracket on the spring strut. A small gap is permissible between bracket and spring strut.
- f. Mix adhesive (EA9309) in accordance with manufacturer's directions.
- g. Spread a coat of adhesive on bonding surfaces, and place step bracket in position on the spring strut. On the flat spring strut, tap the bracket upward on the strut to insure a good tight fit of the bracket on spring strut. On the tubular strut, clamp bracket to strut to insure a good tight fit.
- h. Form a small fillet of the adhesive at all edges of the bonded surfaces. Remove excess adhesive with lacquer thinner.
- i. Allow the adhesive to cure thoroughly according to the manufacturer's recommendations before flexing the gear spring strut or applying loads to the step.
- j. Paint gear spring strut and step bracket after the curing is completed.

5-10. MAIN WHEEL SPEED FAIRING REMOVAL AND INSTALLATION. (Refer to figure 5-2.)

- a. Remove screws attaching stiffener and inboard side of wheel speed fairing to attach plate, which is bolted to the axle.
- b. Remove bolt securing outboard side of fairing to axle nut.
- c. Loosen scraper, if necessary, and work speed fairing from the wheel.
- d. Reverse preceding steps to install wheel speed fairings.
- e. After installation, check scraper-to-tire clearance for a minimum of 0.25-inch to a maximum of 0.38-inch. Elongated holes are provided in the scraper for clearance adjustments.

NOTE

Refer to Cessna Service Kit SK182-12 for repair of wheel speed fairings used on 1969 and 1970 Model aircraft.

CAUTION

Always check scraper-to-tire clearance after installing speed fairing, whenever a tire has been changed, and whenever scraper adjustment has been disturbed. If the aircraft is flown from surfaces with mud, snow, or ice, the speed fairing should be checked to make sure there is no accumulation which could prevent normal wheel rotation. Wipe fuel and oil from the speed fairings to prevent stains and deterioration.

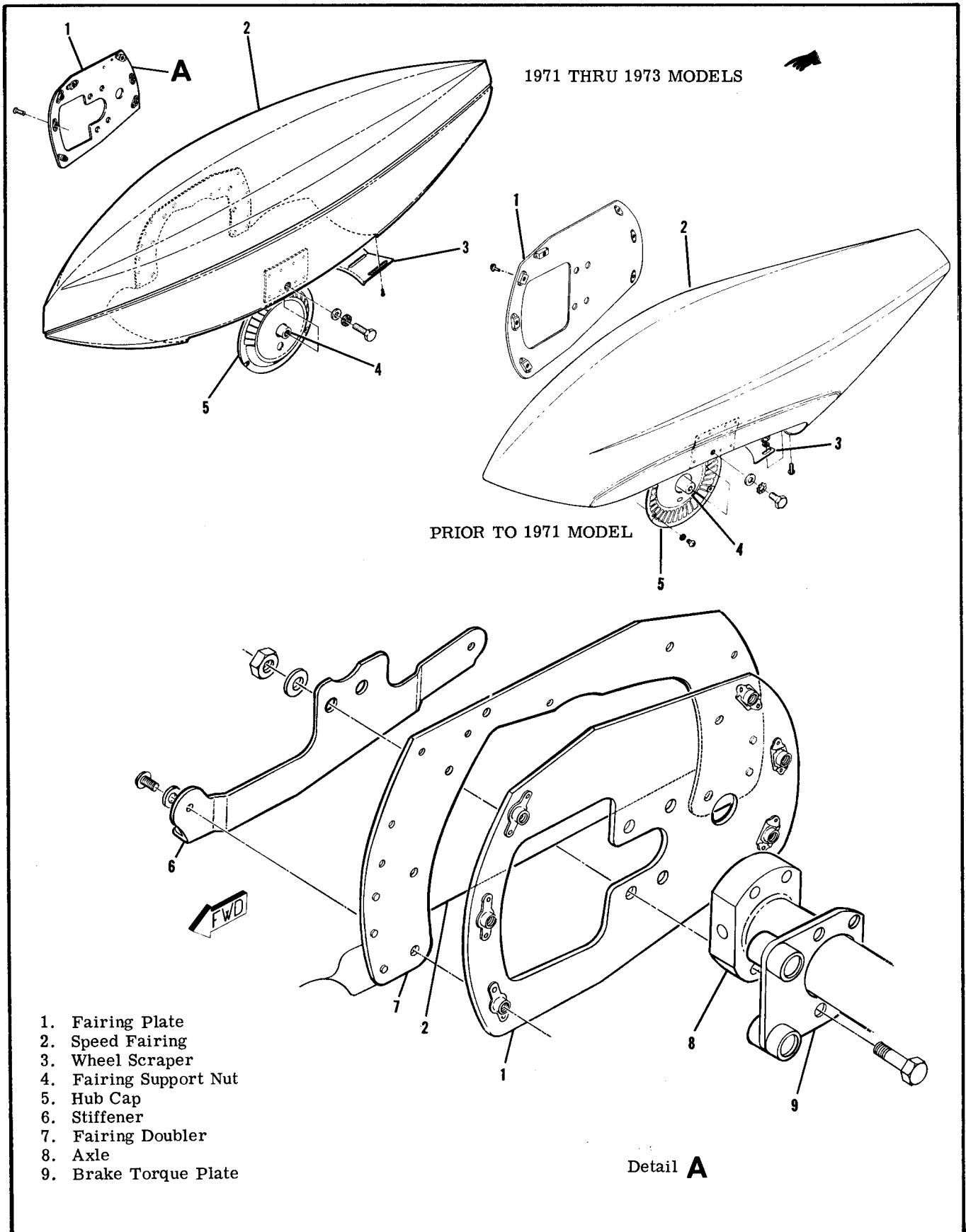

Figure 5-2. Main Wheel Speed Fairing (Sheet 1 of 2)

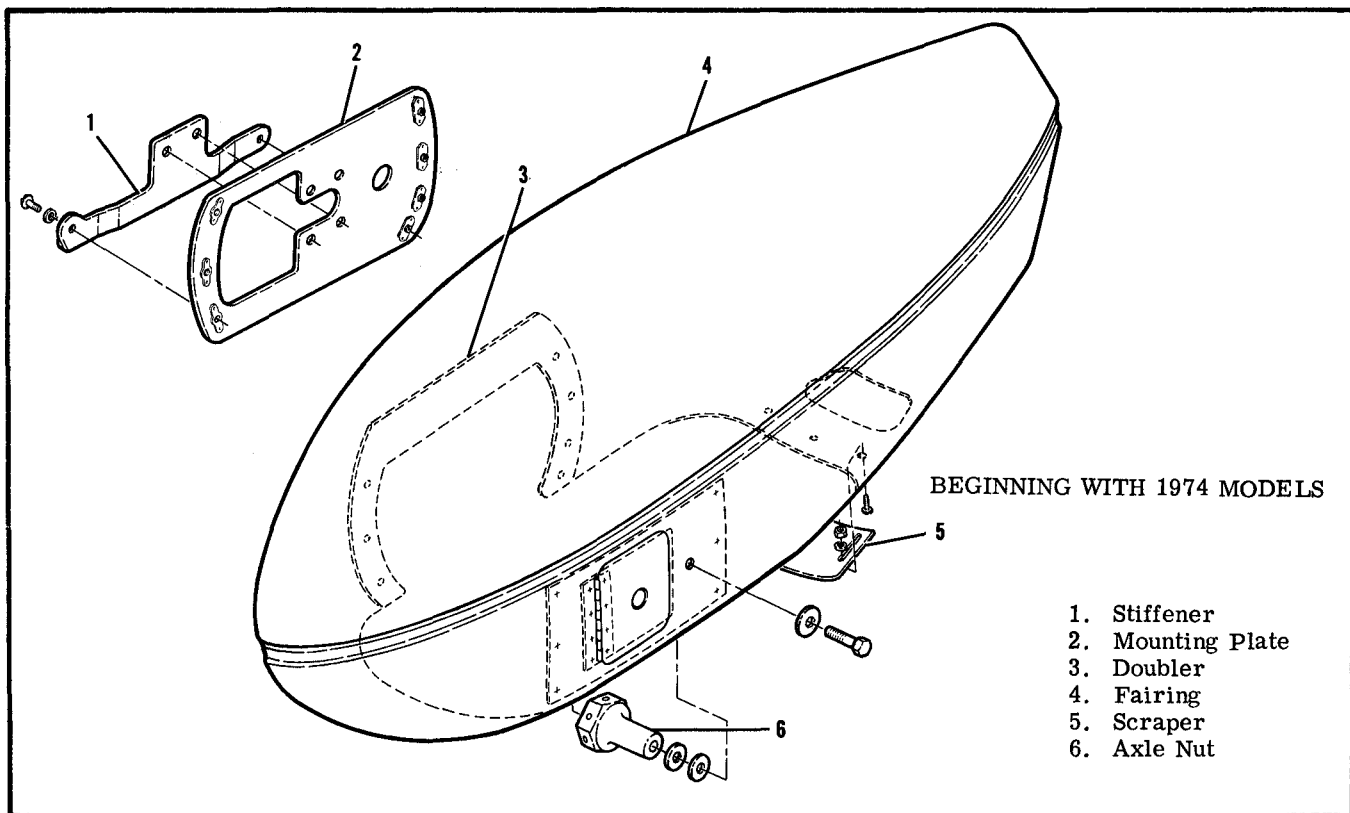

Figure 5-2. Main Wheel Speed Fairing (Sheet 2 of 2)

5-10A. REMOVAL AND INSTALLATION OF MAIN LANDING GEAR FAIRINGS. (Refer to figure 5-1, sheet 2.)

a. To remove brake fairing (19), proceed as follows:

1. Remove screws from perimeter of fairing.
2. Remove screws from nutplates holding fairing together; spring fairing open to slide over spring strut; remove fairing.
3. Reverse preceding steps to install brake fairing.

b. To remove fairing cap (17), proceed as follows:

1. Remove brake fairing (19) as outlined in step "a".
2. Remove screws attaching fairing (17) to spring strut fairing.
3. Remove bolt and nut attaching clamp (18) to spring strut.
4. Slide clamp down tubular strut; remove fairing cap.

NOTE

Clamp may be sprung open over tubular strut for removal.

5. Reverse preceding steps to install fairing cap.

c. To remove fuselage fairing (15), proceed as follows:

1. Remove screws attaching fairing to fuselage.
2. Slide fairing down spring strut fairing.
3. Reverse preceding steps for installation.

d. To remove Spring Strut fairing (16), proceed as follows:

1. Remove brake fairing (19) as outlined in step "a".
2. Remove fairing cap (17) as outlined in step "b".
3. Remove fuselage fairing (15) as outlined in step "c".
4. Remove screws from nutplates along strut.
5. Spring fairing over tubular strut.
6. Reverse preceding steps for installation.

SHOP NOTES:

5-11. MAIN WHEEL REMOVAL (See figure 5-1.)

NOTE

It is not necessary to remove the main wheel to reline brakes or remove brake parts, other than the brake disc on torque plate.

- a. Hoist or jack aircraft as outlined in Section 2.
- b. Remove speed fairing, if installed, in accordance with paragraph 5-10.
- c. Remove hub caps, cotter pin and axle nut.
- d. Remove bolts and washers attaching brake back plate to brake cylinder and remove back plate.
- e. Pull wheel from axle.

5-12. MAIN WHEEL DISASSEMBLY (Cleveland Wheel).

- a. Remove valve core and deflate tire. Break tire beads loose from wheel rims.

WARNING

Injury can result from attempting to separate wheel halves with the tire inflated. Avoid damaging wheel flanges when breaking tire beads loose. A scratch, gouge, or nick may cause wheel failure.

- b. Remove thru-bolts and separate wheel halves, removing tire, tube, and brake disc.
- c. Remove the grease seal rings, felts, and bearing cones from the wheel halves.

NOTE

The bearing cups (races) are a press fit in the wheel halves and should not be removed unless a new part is to be installed. To remove bearing cups, heat wheel half in boiling water for 30 minutes, or in an oven not to exceed 149°C (300°F). Using an arbor press, if available, press out the bearing cup and press in the new bearing cup while the wheel half is still hot.

5-13. MAIN WHEEL INSPECTION AND REPAIR (Cleveland Wheel).

- a. Clean all metal parts and grease seal felts in solvent and dry thoroughly.
- b. Inspect wheel halves for cracks. Cracked wheel halves shall be discarded and new parts used. Sand out nicks, gouges, and corroded areas. When the protective coating has been removed, the area should be cleaned thoroughly, primed with zinc chromate and painted with aluminum lacquer.
- c. If excessively warped or scored, or worn to a thickness of 0.190-inch, brake disc should be replaced with a new part. Sand smooth small nicks and scratches.
- d. Carefully inspect bearing cones and cups for damage and discoloration. After cleaning, pack bearing cones with clean aircraft wheel bearing grease (Section 2) before installing in wheel half.

5-14. MAIN WHEEL REASSEMBLY. (Cleveland Wheel).

- a. Insert thru-bolts through brake disc and position disc in the inner wheel half, using the thru-bolts to guide the disc. Ascertain that the disc is bottomed in the wheel half.
- b. Position tire and tube on outboard wheel half with the tube inflation valve through hole in wheel half.
- c. Place the inner wheel half in position on outboard wheel half. Apply a light force to bring wheel halves together. While maintaining the light force assemble a washer and nut on one thru-bolt and tighten snugly. Assemble the remaining washers and nuts on the thru-bolts and torque to the value stipulated in the chart in figure 5-2A.

CAUTION

Uneven or improper torque of thru-bolt nuts can cause failure of bolts, with resultant wheel failure.

- d. Clean and pack bearing cones with clean aircraft wheel bearing grease (Section 2).
- e. Assemble bearing cones, grease seal felts, and rings into wheel halves.
- f. Inflate tire to seat tire beads, then adjust to correct tire pressure. Refer to Section 1.

5-15. MAIN WHEEL DISASSEMBLY (McCauley Wheel).

- a. Remove valve core and deflate tire and tube. Break tire beads loose from wheel flanges.

WARNING

Injury can result from attempting to remove wheel flanges with the tire and tube inflated. Avoid damaging wheel flanges when breaking tire beads loose. A scratch, gouge or nick in wheel flange could cause wheel failure.

- b. Remove thru-bolt nuts and washers or capscrews from outboard wheel flange.
- c. Remove thru-bolts and washers or capscrews from inboard wheel flange.
- d. Remove brake disc.
- e. Separate wheel flanges from wheel hub. Retain spacers on each side of wheel hub.
- f. Remove wheel hub from tire.
- g. Remove retainer rings and remove grease seal retainers, grease seal felts, and bearing cones.

NOTE

The bearing cups (races) are a press fit in the wheel hub and should not be removed unless a new part is to be installed. To remove the bearing cup, heat wheel hub in boiling water for 30 minutes, or in an oven not to exceed 121°C (250°F). Using an arbor press, if available, press out the bearing cup and press in the new bearing cup while the wheel hub is still hot.

LANDING GEAR WHEEL THRU-BOLT NUT AND CAPSCREW TORQUE VALUES

MAIN GEAR	NOSE GEAR	WHEEL NUMBER	SIZE	MANUFACTURER	NUT/CAPSCREW TORQUE	WHEEL HALF/FLANGE
X		C163001-0103	6.00 X 6	CLEVELAND	150 lb-in	MAGNESIUM
X		C163001-0104	6.00 X 6	CLEVELAND	90 lb-in	ALUMINUM
X		C163002-0101	6.00 X 6	MC CAULEY	90-100 lb-in	ALUMINUM
X		C163003-0101	6.00 X 6	MC CAULEY	*190-200 lb-in	STEEL
	X	C163002-0201	5.00 X 5	MC CAULEY	90-100 lb-in	ALUMINUM
	X	1241156-12	5.00 X 5	CLEVELAND	90 lb-in	MAGNESIUM
	X	C163003-0201	5.00 X 5	MC CAULEY	90-100 lb-in	STEEL
	X	C163003-0401	5.00 X 5	MC CAULEY	*190-200 lb-in	STEEL

*Capscrew

Figure 5-2A. Main and Nose Wheel Thru-Bolt Nut and Capscrew Torque Values

5-16. MAIN WHEEL INSPECTION AND REPAIR (McCauley Wheel).

- a. Clean all metal parts, grease seal felts, and mylar spacers in cleaning solvent and dry thoroughly.
- b. Inspect wheel flanges, and wheel hub for cracks. Cracked wheel flanges or hub shall be discarded and new parts installed. Sand out smooth nicks, gouges, and corroded areas. When the protective coating has been removed, the area should be cleaned thoroughly, primed with zinc chromate and painted with aluminum lacquer.
- c. If excessively warped or scored, or worn to a thickness of 0.190-inch, brake disc should be replaced with a new part. Sand smooth small nicks and scratches.
- d. Carefully inspect bearing cones and cups for damage and discoloration. After cleaning, pack bearing cones with clean aircraft wheel bearing grease (Section 2) before installing in wheel hub.

5-17. MAIN WHEEL REASSEMBLY (McCauley Wheel - Aluminum Flange).

- a. Place wheel hub in tire and tube with tube inflation stem in cutout of wheel hub.
- b. Place spacer and wheel flange on inboard side of wheel hub (opposite of tube inflation stem), then with washer under head of thru-bolt, insert bolt thru brake disc, wheel flange, and wheel hub.
- c. Place spacer and wheel flange on outboard side of wheel hub with valve inflation stem through cutout in wheel flange.
- d. Install washers and nuts on thru-bolts.

CAUTION

Be sure that spacers and wheel flanges are seated on flange of wheel hub. Uneven or improper torque of thru-bolt nuts can cause failure of bolts, with resultant wheel failure.

- e. Tighten thru-bolt nuts evenly and torque to the value stipulated in figure 5-2A.
- f. Clean and pack bearing cones with clean aircraft wheel bearing grease. (Refer to Section 2.)
- g. Assemble bearing cones, grease seal felts, and retainers into wheel hub.
- h. Inflate tire to seat tire beads, then adjust to correct tire pressure. See figure 1-1 for correct tire pressure.

5-17A. MAIN WHEEL REASSEMBLY (McCauley Wheel - Steel Flange).

- a. Place wheel hub in tire and tube with tube inflation stem in cutout of wheel hub.
- b. Place spacer and wheel flange on inboard side of wheel hub (opposite of tube inflation stem).
- c. Place washer under head of each capscrew, insert capscrew thru brake disc, wheel flange, and spacer and start capscrews into wheel hub threads.

CAUTION

Be sure that spacers, wheel flanges and brake disc are seated on flange of wheel hub. Uneven or improper torque of capscrews can cause failure of capscrews or hub threads with resultant wheel failure.

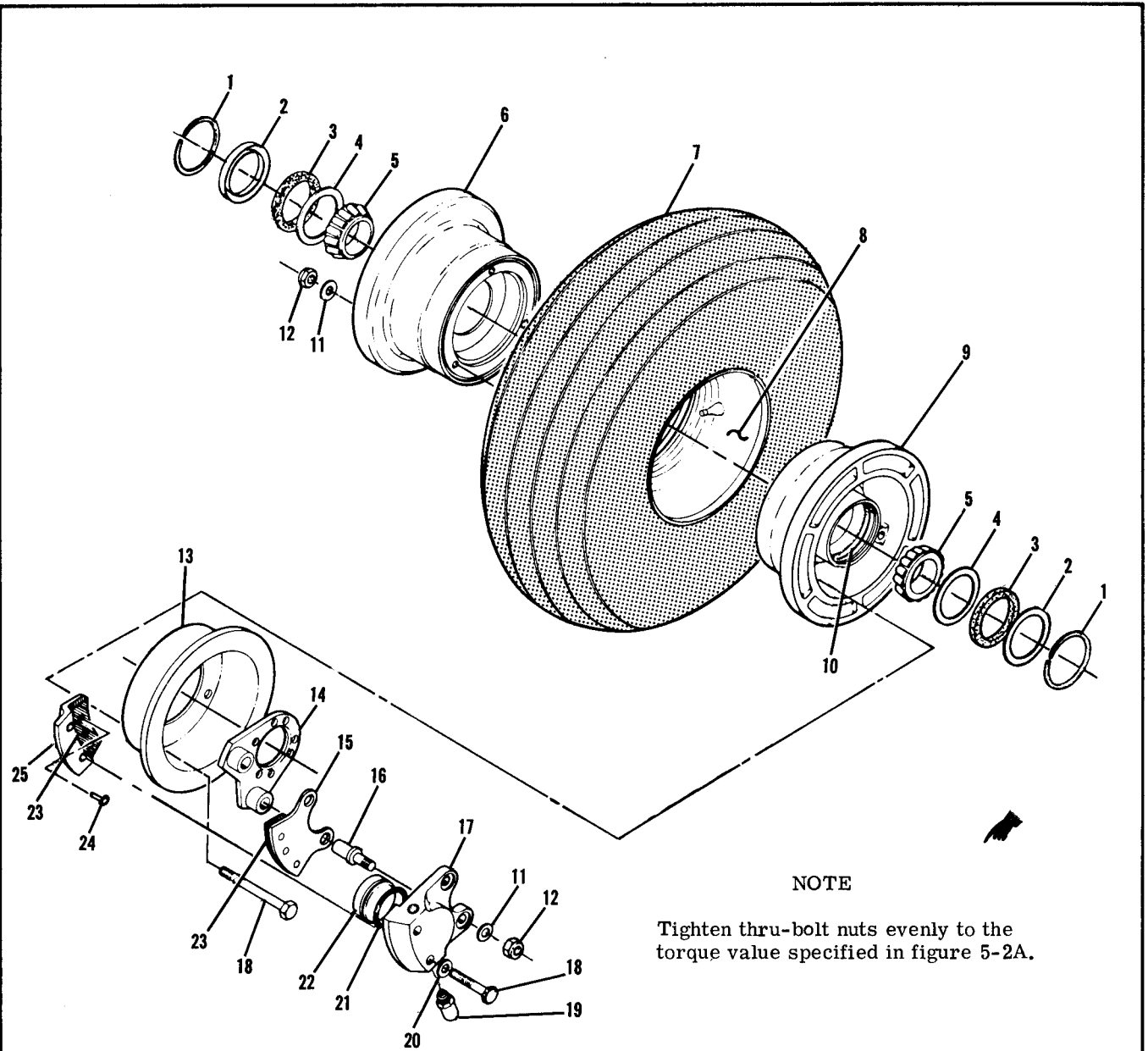

NOTE

Tighten thru-bolt nuts evenly to the torque value specified in figure 5-2A.

CLEVELAND WHEEL AND BRAKE

- | | | |
|------------------------|-----------------------|-------------------|
| 1. Snap Ring | 9. Inboard Wheel Half | 18. Thru-Bolt |
| 2. Grease Seal Ring | 10. Bearing Cup | 19. Bleeder Valve |
| 3. Grease Seal Felt | 11. Washer | 20. Washer |
| 4. Grease Seal Ring | 12. Nut | 21. O-Ring |
| 5. Bearing Cone | 13. Brake Disc | 22. Brake Piston |
| 6. Outboard Wheel Half | 14. Torque Plate | 23. Brake Lining |
| 7. Tire | 15. Pressure Plate | 24. Rivet |
| 8. Tube | 16. Anchor Bolt | 25. Back Plate |
| | 17. Brake Cylinder | |

Figure 5-3. Main Wheel and Brake (Cleveland)

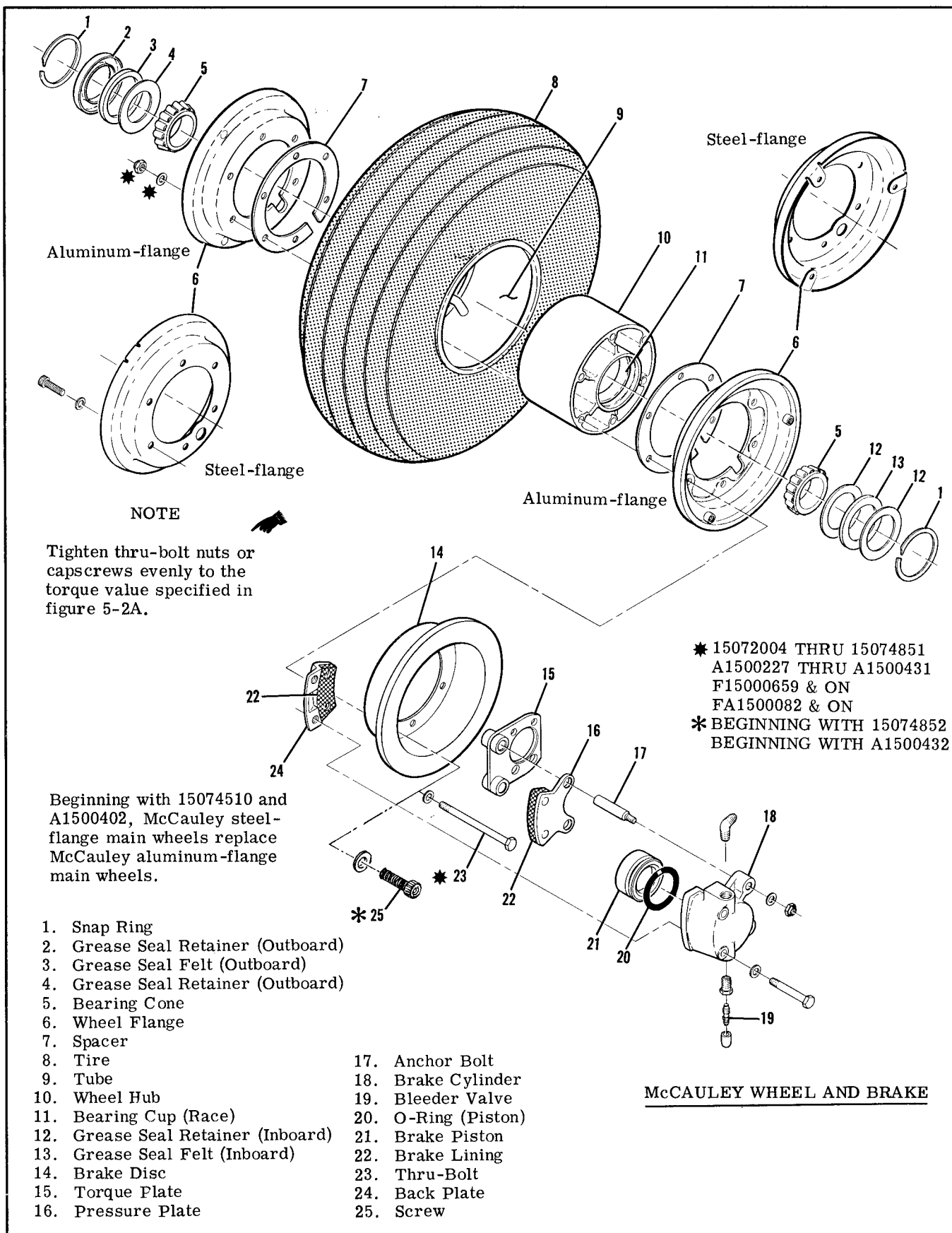

Figure 5-3A. Main Wheel and Brake (McCauley)

d. Tighten capscrews evenly and torque to the value specified in figure 5-2A.

e. Place spacer and wheel flange on outboard side of wheel hub and align valve stem cutout in wheel flange.

f. Place washer under head of each capscrew, insert capscrew thru wheel flange and spacer and start capscrews into wheel hub threads.

CAUTION

Be sure that spacers and wheel flanges are seated on flange of wheel hub. Uneven or improper torque of capscrews can cause failure of the capscrews, or hub threads with resultant wheel failure.

g. Tighten capscrews evenly and torque to values specified in figure 5-2A.

h. Clean and pack bearing cones with clean aircraft wheel bearing grease. (Refer to Section 2 for grease type.)

i. Assemble bearing cones, grease seal felts and retainer into wheel hub.

j. Inflate tire to seat tire beads, then adjust to correct tire pressure. Refer to figure 1-1 for correct tire pressure.

5-18. MAIN WHEEL INSTALLATION.

a. Place wheel assembly on axle.

b. Install axle nut and tighten axle nut until a slight bearing drag is obvious when the wheel is rotated. Back off nut to nearest castellation and install cotter pin.

c. Place brake back plate in position and secure with bolts and washers.

d. Install hub cap. Install speed fairing (if used) as outlined in paragraph 5-10.

CAUTION

Always check scraper-to-tire clearance after installing speed fairings, whenever a tire has been changed, and whenever scraper adjustment has been disturbed. If the aircraft is flown from surfaces with mud, snow, or ice, the fairing should be checked to make sure there is no accumulation which could prevent normal wheel rotation. Refer to paragraph 5-10 for correct scraper-to-tire clearance.

5-19. MAIN WHEEL AXLE REMOVAL (FLAT GEAR).

a. Remove speed fairing, if installed, in accordance with paragraph 5-10.

b. Remove wheel in accordance with paragraph 5-11.

c. Disconnect drain, and plug or cap the hydraulic brake line at the wheel brake cylinder.

d. Remove four nuts, washers, and bolts securing

axle, brake components, and speed fairing mounting plate (if used) to spring strut.

NOTE

When removing axle from spring-strut, note number and position of the wheel alignment shims between axle and spring-strut. Mark these shims or tape them together carefully so they can be installed in exactly the same position to ensure wheel alignment is not disturbed.

5-20. MAIN WHEEL AXLE INSTALLATION (FLAT GEAR).

a. Secure axle and brake components to spring-strut, making sure that wheel alignment shims and speed fairing mounting plate (if used) are installed in their original position. Ascertain that bushings in brake torque plate are installed in the upper mounting holes.

b. Install wheel assembly on axle in accordance with paragraph 5-18.

c. Connect hydraulic brake line to wheel brake cylinder.

d. Fill and bleed affected brake system in accordance with paragraph 5-58.

e. Install speed fairing (if used) in accordance with paragraph 5-10.

5-21. MAIN WHEEL AXLE REMOVAL (TUBULAR).

Refer to figure 5-4.

NOTE

Axles are bonded to the struts of tubular gear aircraft with (3M) EC2216 adhesive. The bond is too strong to allow the axle to be removed without first weakening the bond strength. The only methods of weakening the bond are with heat or cryogenic cold; heat being the most practical. A temperature of approximately 500°F. is sufficient to weaken the bond so the axle can be removed. This is still a low enough temperature to prevent damage to the tubular strut, but will age the aluminum axle. Therefore, the axle will have to be replaced.

a. Remove speed fairings, if installed, in accordance with procedures outlined in paragraph 5-10.

b. Remove wheels as outlined in paragraph 5-11.

c. Disconnect, drain, and cap or plug hydraulic brake line at the wheel brake cylinder.

d. Remove cotter pin, nut and bolt attaching axle to spring strut.

e. Remove brake components and speed fairing plate from axle.

f. Remove axle as follows:

CAUTION

Do not place tape in direct contact with tubular gear spring.

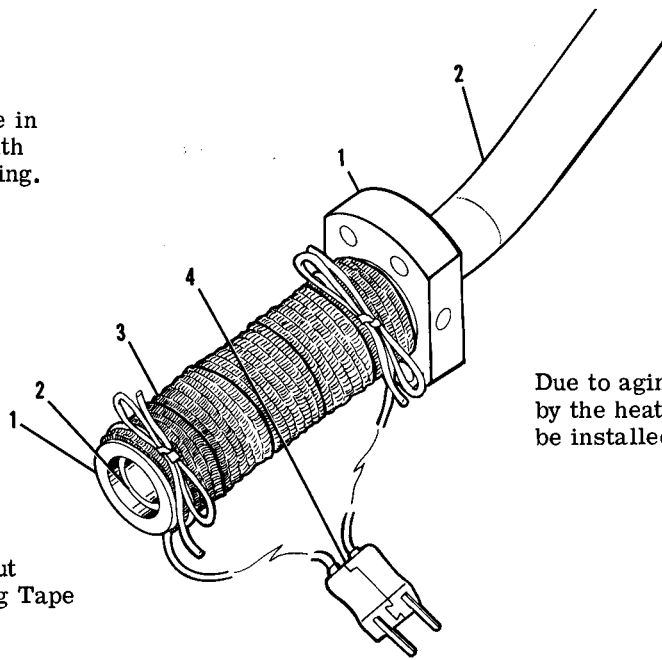

1. Axle
2. Tubular Gear Strut
3. Electrical Heating Tape
4. Plug

CAUTION

Due to aging of the aluminum axle, caused by the heating tape, a new axle will have to be installed.

Figure 5-4. Main Wheel Axle Removal

5-21. MAIN WHEEL AXLE REMOVAL (TUBULAR).
Refer to figure 5-4.

NOTE

Axles are bonded to the struts of tubular gear aircraft with (3M) EC2216 adhesive. The bond is too strong to allow the axle to be removed without first weakening the bond strength. The only methods of weakening the bond are with heat or cryogenic cold; heat being the most practical. A temperature of approximately 500°F. is sufficient to weaken the bond so the axle can be removed. This is still a low enough temperature to prevent damage to the tubular strut, but will age the aluminum axle. Therefore, the axle will have to be replaced.

- a. Remove speed fairings, if installed, in accordance with procedures outlined in paragraph 5-10.
- b. Remove wheels as outlined in paragraph 5-11.
- c. Disconnect, drain, and cap or plug hydraulic brake line at the wheel brake cylinder.
- d. Remove cotter pin, nut and bolt attaching axle to spring strut.
- e. Remove brake components and speed fairing plate from axle.
- f. Remove axle as follows:

NOTE

Axle should be removed from strut, using electric heating tape, which is available from Curtin Scientific Company, 6550 East 42nd St., P.O. Box 147, Tulsa, Oklahoma 74101. Tape should conform to the following: 192 watts, 24" long, 1" wide, flexible and heavily insulated.

1. Wrap heating tape around axle from base head to outer end of axle and tie it on with string provided with tape.

CAUTION

Do not place tape in direct contact with tubular gear spring.

2. Plug electric tape into 110 volt wall socket and heat for 20 to 30 minutes.
3. Unplug tape and remove from axle. Remove axle by striking axle base head with a few sharp blows.
4. Clean any old adhesive off landing gear spring with a wire brush. Brush strokes should run lengthwise along the spring. After old adhesive has been removed, wipe with clean rag saturated with acetone or alcohol. Immediately wipe dry with a clean, lint free cloth.

CAUTION

Due to aging of the aluminum axle, caused by the heating tape, a new axle will have to be installed.

5-22. MAIN WHEEL AXLE INSTALLATION
(TUBULAR).

- a. Prior to installing new axle, wipe outer surface of tubular gear and inside surface of axle with solvent, drying immediately with a clean, lint free cloth.
- b. Install new axles as follows:
 1. Mix EA9309, EC2216 or equivalent adhesive, in accordance with instructions in package. Spread adhesive thinly and evenly on outer surface of landing gear spring in area that will be covered by axle.

numbers and the correction imposed on the wheel by the various shims are listed in sheet 2 of figure 5-5.

NOTE

Failure to obtain acceptable wheel alignment through the use of the shims indicate a deformed main gear spring-strut or spring-strut attaching bulkhead out of alignment.

5-23A. MAIN WHEEL ALIGNMENT (TUBULAR).
(Refer to figure 1-1.)

5-24. WHEEL BALANCING. Since uneven tire wear is usually the cause of wheel unbalance, replacing the tire probably will correct this condition. Tire and tube manufacturing tolerances permit a specified amount of static unbalance. The light-weight point of the tire is marked with a red dot on the tire sidewall and the heavy-weight point of the tube is marked with a contrasting color line (usually near the inflation valve stem). When installing a new tire, place these marks adjacent to each other. If a wheel shows evidence of unbalance during service, it may be statically balanced. Wheel balancing equipment is available from the Cessna Service Parts Center.

5-25. NOSE GEAR. The steerable nose wheel mounted on an air-oil shock strut comprises the nose gear. The shock strut is secured to the tubular engine mount. Nose wheel steering is accomplished by two spring-loaded push-pull tubes linking the nose gear steering collar to the rudder pedal bars. A hydraulic fluid-filled shimmy dampener is provided to minimize nose wheel shimmy. A nose wheel speed fairing may be installed as optional equipment. The various configurations of these optional nose wheel speed fairings are illustrated in figure 5-7. Disassembly, inspection and repair, and reassembly of the various nose wheel configurations are described in separate paragraphs for each configuration. The solid wheels having two wheel halves are manufactured by Cleveland Aircraft Products Co. and webbed wheels having two flanges and a hub are manufactured by McCauley Industrial Corporation. The Cleveland wheels are shown in figure 5-8. The McCauley wheels have either aluminum flanges or steel flanges as shown in figure 5-8A. The aluminum flanges are attached to the wheel hub by thru-bolts and nuts as shown in figure 5-8A. The steel flanges are attached to the wheel hub by either thru-bolts or capscrews as shown in figure 5-8A. During assembly of the nose wheel, the thru-bolt nuts or capscrews, as applicable, shall be tightened evenly and torqued to the value specified in figure 5-2A.

5-26. TROUBLE SHOOTING.

TROUBLE	PROBABLE CAUSE	REMEDY
NOSE WHEEL SHIMMY.	Nose strut attaching bolts loose.	Tighten nose strut attaching bolts.
	Loose or worn nose wheel steering linkage.	Tighten. Replace defective parts with new parts.
	Nose wheel out of balance.	Refer to paragraph 5-36.
	Wheel bearings too loose.	Adjust properly.
	Defective shimmy dampener.	Repair, or install new shimmy dampener.
	Shimmy dampener fluid low.	Refer to Section 2.
	Loose torque links.	Add shims, or install new parts as required.
NOSE STRUT DOES NOT HOLD AIR PRESSURE.	Defective or loose air filler valve.	Check gasket and tighten loose valve. Install new valve if defective.
	Defective strut seals	Install new seals.
HYDRAULIC FLUID LEAKAGE FROM NOSE STRUT.	Defective strut seals.	Install new seals.

REFER TO FIGURE 1-1
FOR TOE-IN AND CAMBER.

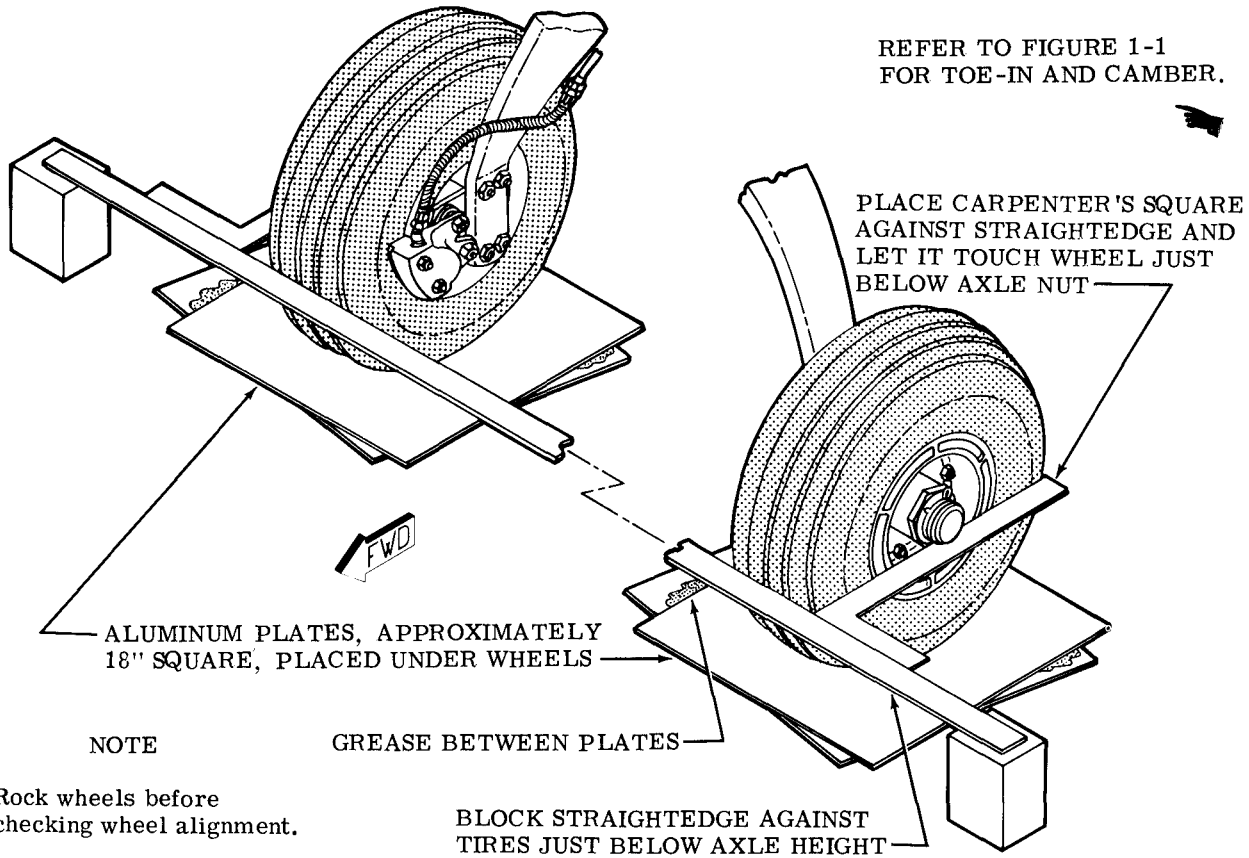

NOTE

GREASE BETWEEN PLATES

Rock wheels before
checking wheel alignment.

BLOCK STRAIGHTEDGE AGAINST
TIRES JUST BELOW AXLE HEIGHT

TOP VIEW OF TOE-IN CHECK

Measure toe-in at edges of wheel flange. Difference in measurements is toe-in for one wheel. (half of total toe-in.)

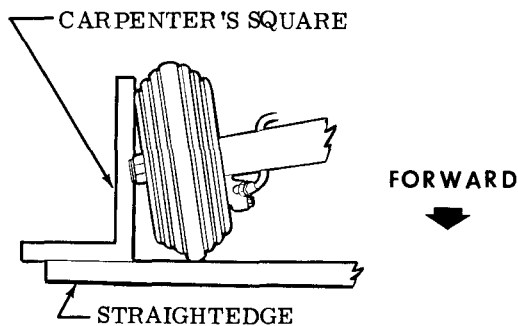

FRONT VIEW OF CAMBER CHECK

Measure camber by reading protractor level held vertically against outboard flanges of wheel.

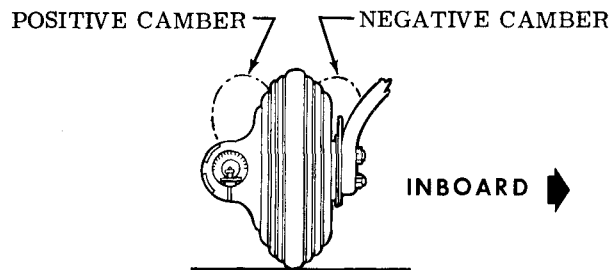

NOTE

Setting toe-in and camber within these tolerances while the cabin and fuel tanks are empty will give approximately zero toe-in and zero camber at gross weight. Therefore, if normal operation is at less than gross weight and abnormal tire wear occurs, realign the wheels to attain the ideal setting for the load conditions. Refer to sheet 2 of this figure for shims availability and their usage. Always use the least number of shims possible to obtain the desired result.

Figure 5-5. Main Wheel Alignment (Sheet 1 of 2)

SHIM PART NO.	POSITION OF THICKEST CORNER OR EDGE OF SHIM	CORRECTION IMPOSED ON WHEEL			
		TOE-IN	TOE-OUT	POS. CAMBER	NEG. CAMBER
0541157-1	AFT FWD	.06" ----	---- .06"	---- 0°3'	0°3' ----
0541157-2	UP DOWN	.006" ----	---- .006"	0°30' ----	---- 0°30'
0541157-3	AFT FWD	.12" ----	---- .12"	---- 0°7'	0°7' ----
0541111-2	UP & FWD UP & AFT DOWN & FWD DOWN & AFT	---- .23" ---- .15"	.15" ---- .23" ----	2°50' 2°29' ---- ----	---- ---- 2°29' 2°50'
0441139-5	UP & FWD UP & AFT DOWN & FWD DOWN & AFT	---- .12" ---- .11"	.11" ---- .12" ----	0°25' 0°11' ---- ----	---- ---- 0°11' 0°25'
0441139-6	UP & FWD UP & AFT DOWN & FWD DOWN & AFT	---- .24" ---- .22"	.22" ---- .24" ----	0°50' 0°22' ---- ----	---- ---- 0°22' 0°50'
1241061-1	UP & FWD UP & AFT DOWN & FWD DOWN & AFT	.03" .06" ---- ----	---- ---- .06" .03"	2°50' 2°49' ---- ----	---- ---- 2°49' 2°50'

Figure 5-5. Main Wheel Alignment (Sheet 2 of 2)

5-27. NOSE GEAR REMOVAL AND INSTALLATION.
(See figure 5-6.)

- a. Remove engine cowling for access.
- b. Weight or tie-down tail of aircraft to raise nose wheel off the floor.
- c. Disconnect nose wheel steering tubes from nose gear steering collar.
- d. Remove screws attaching hose clamps to strut.
- e. Remove air filler valve core and deflate strut completely and telescope strut to its shortest length.

WARNING

Be sure the strut is deflated completely before removing bolt or roll pin at top of strut.

- f. Remove roll pin at top of strut and remove bolt which clamps strut to lower part of engine mount.
- g. Pull the strut assembly down out of engine mount fitting.
- h. To install the nose gear, reverse the preceding steps. Always install roll pin before clamping strut in lower portion of engine mount to prevent misalignment. Tighten clamp bolt in lower portion of engine

mount fitting to 120 ± 20 lb-in.

5-28. NOSE WHEEL SPEED FAIRING REMOVAL AND INSTALLATION.

- a. Weight or tie-down tail of aircraft to raise nose wheel off the floor.
- b. Remove nose wheel axle stud.
- c. Remove bolt securing cover plate and fairing to strut. Remove cover plate.

WARNING

Do not remove bolt attaching tow-bar spacers, unless strut has been deflated completely.

- d. Slide speed fairing up and remove nose wheel. Loosen scraper as necessary.
- e. Rotate speed fairing 90 degrees and work fairing down over the fork to remove.
- f. Install speed fairing by reversing the preceding steps. Tighten axle stud until a slight bearing drag is obvious when the wheel is rotated. Back off nut to the nearest castellation and install cotter pins.

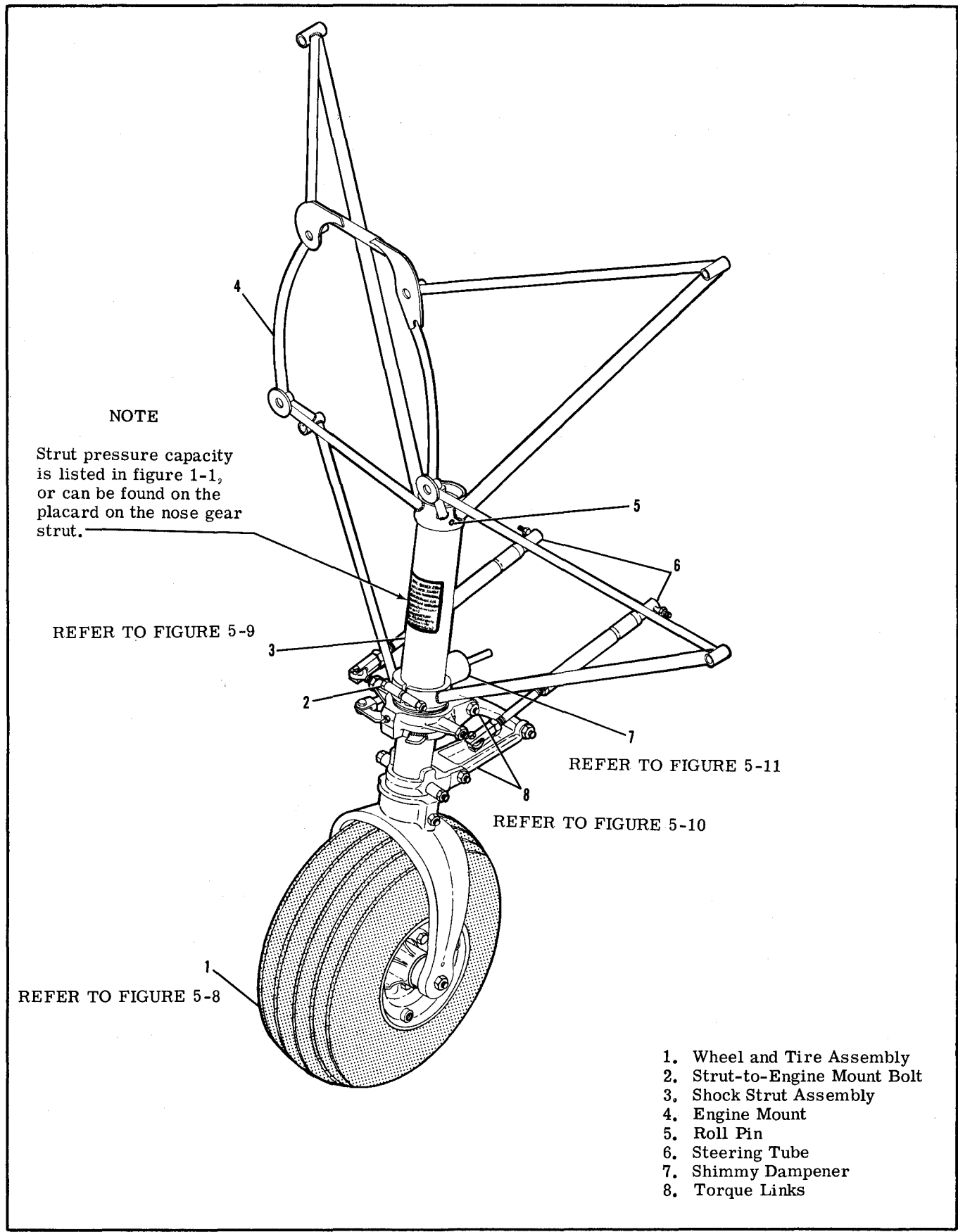

NOTE

Strut pressure capacity is listed in figure 1-1, or can be found on the placard on the nose gear strut.

REFER TO FIGURE 5-9

REFER TO FIGURE 5-11

REFER TO FIGURE 5-10

REFER TO FIGURE 5-8

- 1. Wheel and Tire Assembly
- 2. Strut-to-Engine Mount Bolt
- 3. Shock Strut Assembly
- 4. Engine Mount
- 5. Roll Pin
- 6. Steering Tube
- 7. Shimmy Dampener
- 8. Torque Links

Figure 5-6. Nose Gear Installation

g. If shock strut was deflated, service after installation has been completed (see Section 2).

CAUTION

Always check scraper clearance after installing speed fairing, whenever a tire has been changed, and whenever scraper adjustment has been disturbed. Set clearance between tire and scraper for a minimum of 0.25 inch to a maximum of 0.38 inch. Elongated holes in the scraper are provided for adjustment. If the aircraft is flown from surfaces with mud, snow, or ice, the speed fairings should be checked to make sure there is no accumulation which could prevent normal wheel rotation. Wipe fuel and oil from speed fairing to prevent stains and deterioration of the fairing.

5-29. NOSE WHEEL REMOVAL AND INSTALLATION.

- a. Weight or tie-down tail of aircraft to raise the nose wheel off the floor.
- b. Remove nose wheel axle bolt.
- c. Pull nose wheel assembly from fork and remove axle tube from nose wheel. Loosen scraper if necessary.
- d. Reverse the preceding steps to install nose wheel. Tighten axle bolt until a slight bearing drag is obvious when wheel is rotated. Back the nut off to the nearest castellation and install cotter pin.

CAUTION

On aircraft equipped with speed fairings, always check scraper-to-tire clearance after installing speed fairing, whenever a tire has been changed, or whenever scraper adjustment has been disturbed. Set scraper clearance in accordance with paragraph 5-28.

5-30. NOSE WHEEL DISASSEMBLY (Cleveland Wheel).

- a. Remove hub caps, completely deflate tire and break tire beads loose at wheel rim.

WARNING

Injury can result from attempting to separate wheel halves with the tire inflated. Avoid damaging wheel flanges when breaking tire beads loose.

- b. Remove thru-bolts and separate wheel halves.
- c. Remove tire and tube from wheel halves.
- d. Remove bearing retaining rings, grease felt seals and bearing cones.

NOTE

The bearing cups (races) are a press fit in the wheel halves and should not be removed unless a new part is to be installed. To remove bearing cups, heat wheel halves in boiling water for 30 minutes, or in an oven not to exceed 149°C (300°F). Using an arbor press, if available, press out the

bearing cup and press in the new bearing cup while the wheel half is still hot.

5-31. NOSE WHEEL INSPECTION AND REPAIR (Cleveland Wheel).

- a. Clean all metal parts and grease seal felts in solvent and dry thoroughly.
- b. Inspect wheel halves for cracks. Cracked wheel halves shall be discarded and new parts used. Sand out nicks, gouges, and corroded areas. When protective coating has been removed, the area should be cleaned thoroughly, primed with zinc chromate and painted with aluminum lacquer.
- c. Carefully inspect bearing cones and cups for damage and discoloration. After cleaning, pack bearing cones with clean aircraft wheel bearing grease (Section 2) before installing in wheel half.

5-32. NOSE WHEEL REASSEMBLY (Cleveland Wheel).

- a. Insert tube in tire, aligning index marks on tire and tube.
- b. Place tire and tube on wheel half and position valve stem through hole in wheel half.
- c. Insert thru-bolts, position other wheel half, and secure with nuts and washers. Take care to avoid pinching tube between wheel halves. Tighten thru-bolt nuts to the torque values stipulated in figure 5-2A.

CAUTION

Uneven or improper torque on the thru-bolt nuts may cause bolt failure with resultant wheel failure.

- d. Clean and pack bearing cones with clean aircraft wheel bearing grease (Section 2).
- e. Assemble bearing cones, seals, and retainers into the wheel halves.
- f. Inflate tire to seat tire beads, then adjust to correct pressure (figure 1-1).

5-33. NOSE WHEEL DISASSEMBLY (McCauley Wheel with Thru-bolts).

- a. Remove hub caps, completely deflate tire, and break tire beads loose at wheel flanges.

WARNING

Injury can result from attempting to remove wheel flanges with tire and tube inflated. Avoid damaging wheel flanges when breaking tire beads loose. A scratch, gouge or nick in wheel flange may cause wheel failure.

- b. Remove thru-bolt nuts and washers.
- c. Remove thru-bolts and separate wheel flanges from wheel hub. Retain spacers between wheel flanges and wheel hub.
- d. Remove wheel hub from tire and tube.
- e. Remove retainer rings and remove grease seal retainers, grease seal felts, and bearing cones from wheel hub.

1971 THRU 1973 MODELS

PRIOR TO 1971 MODEL

BEGINNING WITH 1974 MODELS

- 1. Speed Fairing
- 2. Cover Plate
- 3. Fork Bolt
- 4. Scraper
- 5. Axle Stud
- 6. Ferrule
- 7. Hub Cap

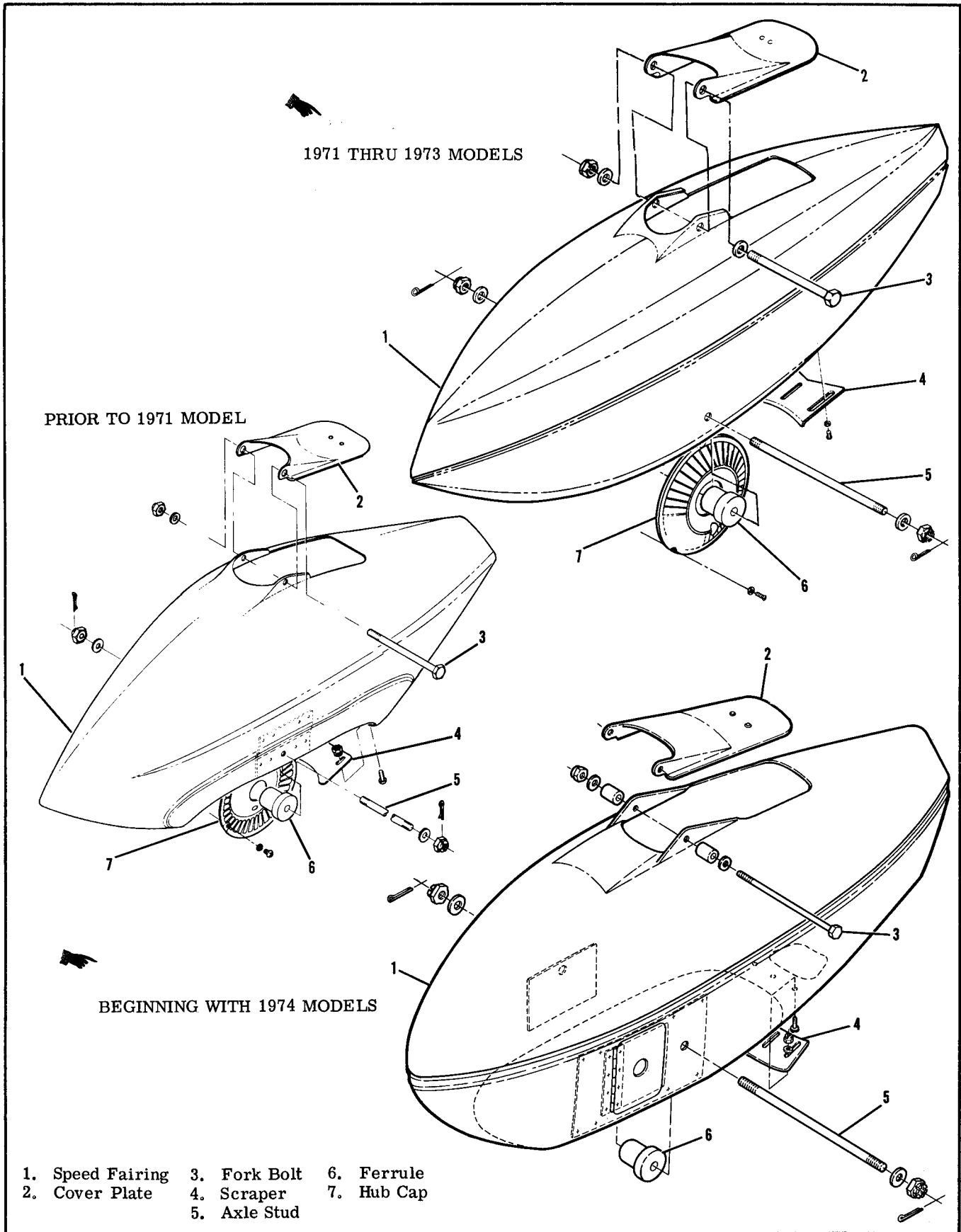

Figure 5-7. Nose Wheel Speed Fairing

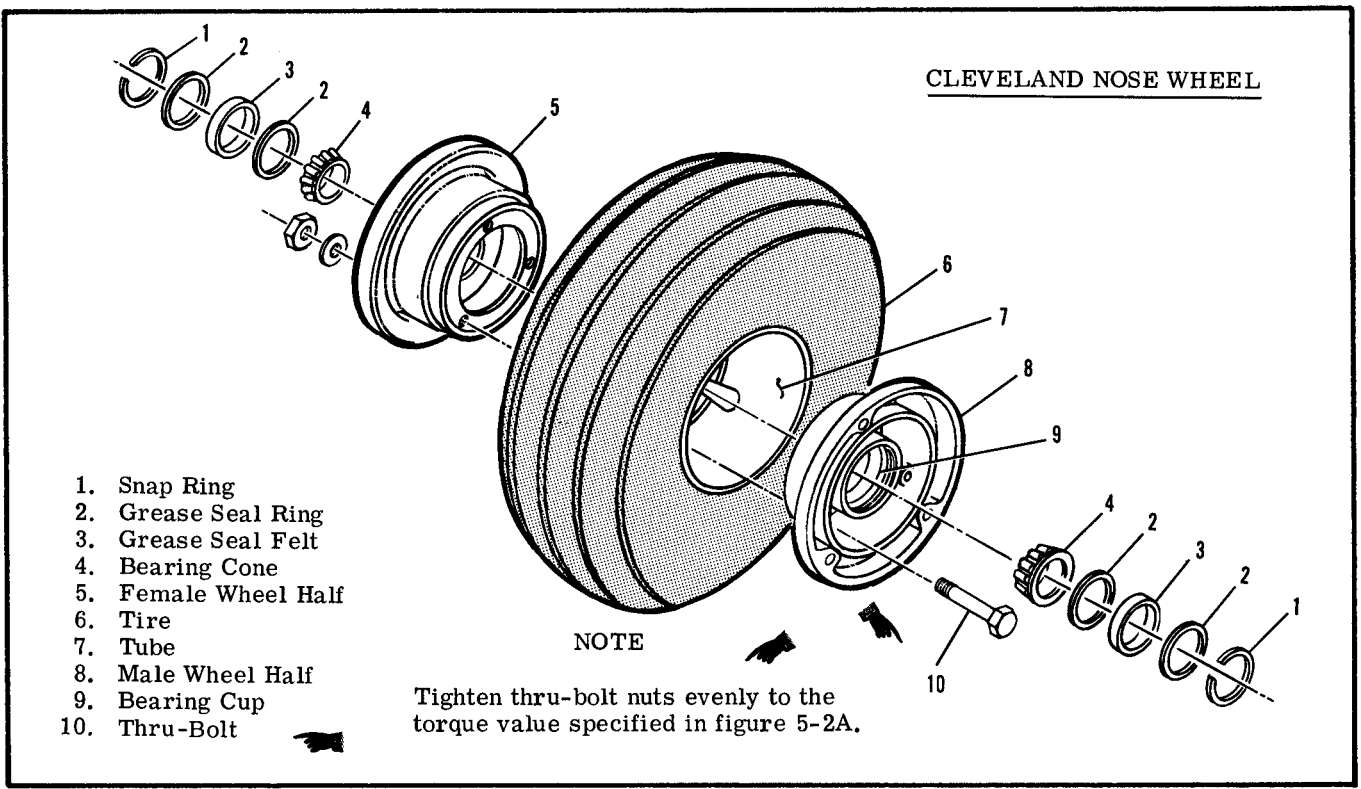

Figure 5-8. Nose Wheel and Tire (Cleveland)

NOTE

The bearing cups (races) are a press fit in the wheel hub and should not be removed unless a new part is to be installed. To remove the bearing cup, heat wheel hub in boiling water for 30 minutes, or in an oven not to exceed 121°C (250°F). Using an arbor press, if available, press out the bearing cup and press in the new bearing cup while the wheel hub is still hot.

- wheel hub and with washer under head of thru-bolt insert bolt through wheel flange and wheel hub.
- d. Place spacer and wheel flange on other side and align valve stem in cutout in wheel flange.
- e. Install washers and nuts on thru-bolts.

CAUTION

Be sure that spacers and wheel flanges are seated on flange of wheel hub. Uneven or improper torque of the thru-bolt nuts can cause failure of the bolts, with resultant wheel failure.

5-34. NOSE WHEEL INSPECTION AND REPAIR (McCauley Wheel with Thru-bolts).

- a. Clean all metal parts, grease seal felts, and mylar spacers in cleaning solvent and dry thoroughly.
- b. Inspect wheel flanges, and wheel hub for cracks. Cracked wheel flanges or hub shall be discarded and new parts installed. Sand out smooth nicks, gouges, and corroded areas. When the protective coating has been removed, the area should be cleaned thoroughly, primed with zinc chromate and painted with aluminum lacquer.
- c. Carefully inspect bearing cones and cups for damage and discoloration. After cleaning, pack bearing cones with clean aircraft wheel bearing grease (Section 2) before installing in wheel hub.

- f. Tighten thru-bolt nuts evenly and torque to the values stipulated in figure 5-2A.
- g. Clean and pack bearing cones with clean aircraft wheel bearing grease (Section 2).
- h. Assemble bearing cones, grease seal felts and retainers into wheel hub.
- i. Inflate tire to seat tire beads, then adjust to correct tire pressure. See figure 1-1 for correct tire pressure.

5-35. NOSE WHEEL REASSEMBLY (McCauley Wheel with Thru-bolts).

- a. Insert tube in tire, aligning index marks on tire and tube.
- b. Place wheel hub in tire with valve stem in cutout of wheel hub.
- c. Place spacer and wheel flange on one side of

5-35A. NOSE WHEEL DISASSEMBLY (McCauley Wheel with Capscrews).

- a. Remove hub caps, completely deflate tire and break tire beads loose at wheel flanges.

WARNING

Injury can result from attempting to remove wheel flanges with tire and tube inflated. Avoid damaging wheel flanges when breaking tire beads loose. A scratch, gouge or nick in wheel flange could cause wheel failure.

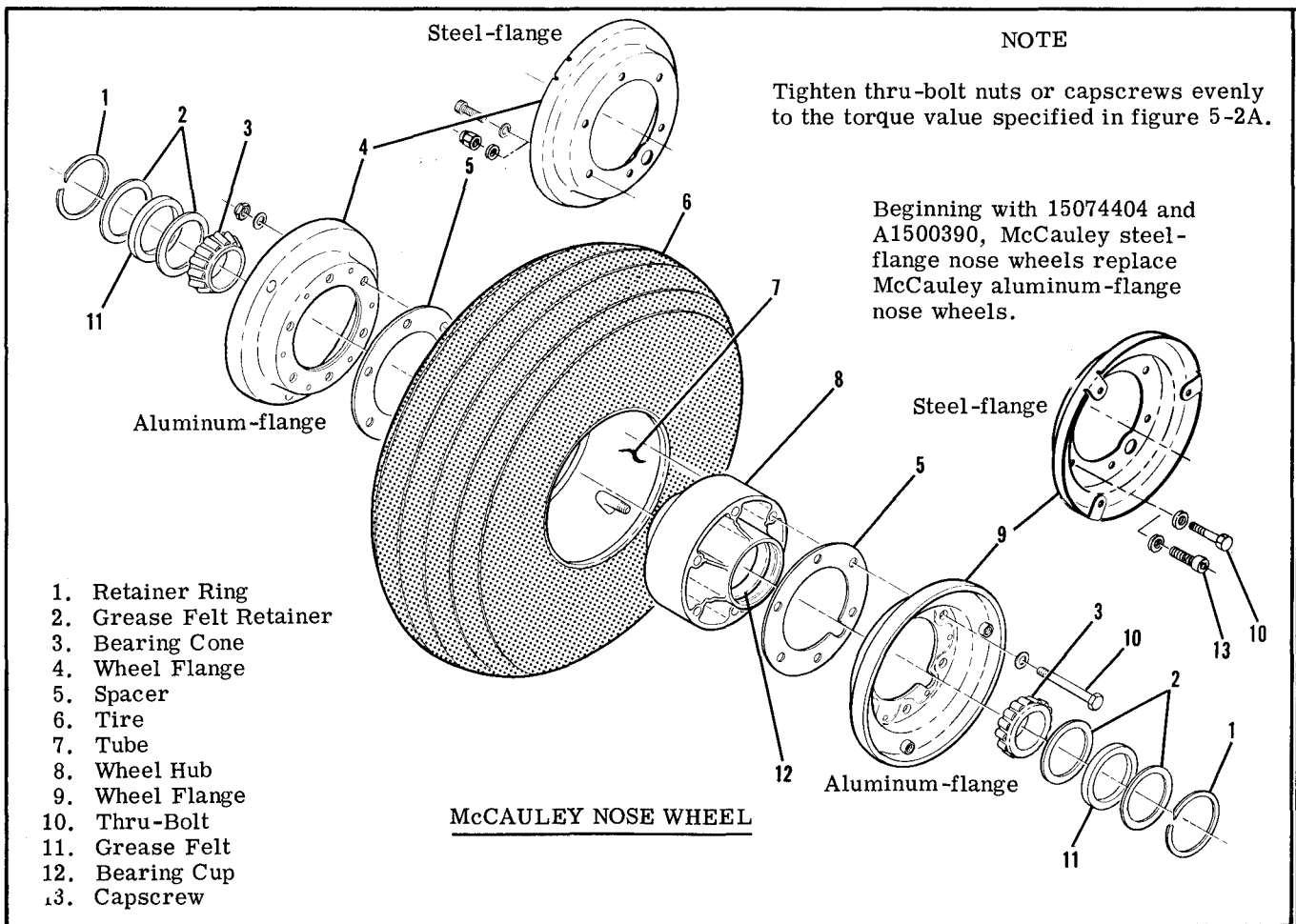

Figure 5-8A. Nose Wheel and Tire (McCauley)

- b. Remove capscrews and washers.
- c. Separate wheel flanges from wheel hub. Retain spacers on each side of wheel hub.
- d. Remove wheel hub from tire.
- e. Remove retainer rings and remove grease seal retainers, grease seal felts and bearing cones.

NOTE

The bearing cups (races) are a press-fit in the wheel hub and should not be removed unless a new part is to be installed. To remove the bearing cup, heat wheel hub in boiling water for 30 minutes, or in an oven not to exceed 121°C(250°F). Using an arbor press, if available, press in the new bearing cup while the wheel hub is still hot.

5-35B. NOSE WHEEL INSPECTION AND REPAIR (McCauley Wheel with Capscrews).
Refer to paragraph 5-34.

5-35C. NOSE WHEEL REASSEMBLY (McCauley Wheel with Capscrew).

- a. Insert tube in tire, aligning index marks on tire and tube.
- b. Place wheel hub in tire with valve stem in cutout of wheel hub.
- c. Place spacer and wheel flange on one side of

wheel hub.

- d. Place washer under head of each capscrew, insert capscrew thru wheel flange and spacer and start capscrews into wheel hub threads.

CAUTION

Be sure that spacers and wheel flanges are seated on flange of wheel hub. Uneven or improper torque of capscrews can cause failure of the capscrews or hub threads with resultant wheel failure.

- e. Tighten capscrews evenly and torque to the value specified in figure 5-2A.
- f. Place spacer and wheel flange on other side of wheel hub and align valve stem in cutout in wheel flange.
- g. Place washer under head of each capscrew, insert capscrew thru wheel flange and spacer and start capscrews into wheel hub threads.

CAUTION

Be sure that spacers and wheel flanges are seated on flange of wheel hub. Uneven or improper torque of capscrews can cause failure of the capscrews or hub threads with resultant wheel failure.

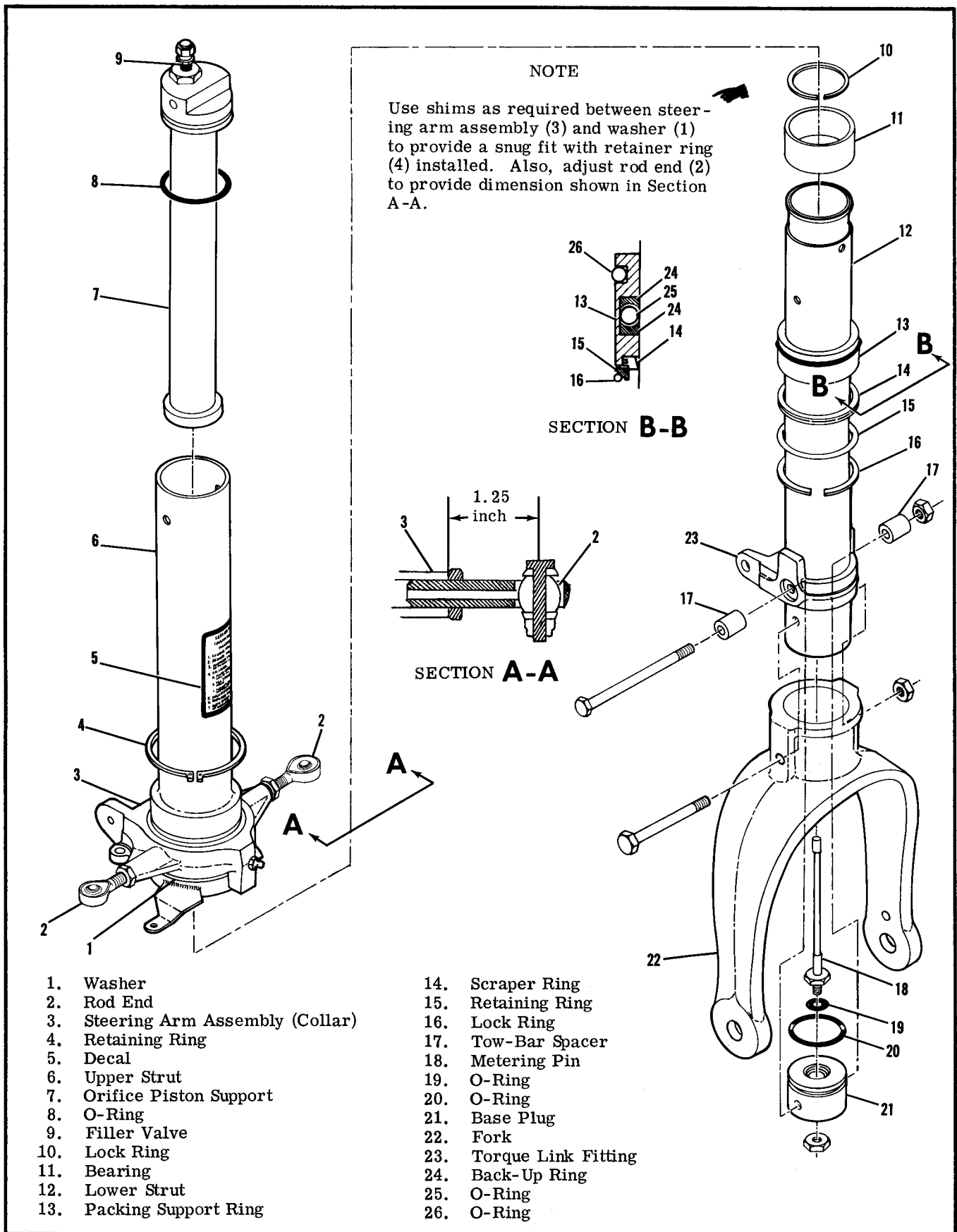

Figure 5-9. Nose Gear Shock Strut

- h. Tighten capscrews evenly and torque to the value specified in figure 5-2A.
- i. Clean and pack bearing cones with clean aircraft wheel bearing grease. (Refer to Section 2 for grease type.)
- j. Assemble bearing cones, grease seal felts and retainer into wheel hub.
- k. Inflate tire to seat tire beads, then adjust to correct tire pressure (refer to Section 1).

5-36. WHEEL BALANCING. Refer to paragraph 5-24 for wheel balancing information.

5-37. NOSE GEAR SHOCK STRUT DISASSEMBLY. (See figure 5-9.) The following procedures apply to the nose gear shock strut after it has been removed from the aircraft, and the speed fairing and nose wheel have been removed. In many cases, separation of the upper and lower strut will permit inspection and parts installation without removal or complete disassembly of the strut.

WARNING

Be sure strut is completely deflated before removing lock ring in lower end of upper strut, or disconnecting torque links.

- a. Remove shimmy dampener.
- b. Remove torque links. Note position of washers, shims, and spacers.
- c. Remove lock ring from groove inside lower end of upper strut. A small hole is provided at the lock ring groove to facilitate removal of the lock ring.

NOTE

Hydraulic fluid will drain from strut as lower strut is pulled from upper strut.

- d. Using a straight sharp pull, separate upper and lower struts. Invert lower strut and drain hydraulic fluid.
- e. Remove lock ring and bearing at upper end of lower strut assembly. Note top side of bearing.
- f. Slide packing support ring, scraper ring, retaining ring, and lock ring from lower strut, noting relative position and top side of each ring; wire together if desired.
- g. Remove O-rings and back-up rings from packing support ring.
- h. Remove bolt securing tow bar spacers and slide torque link fitting from lower strut.

NOTE

Bolt attaching tow bar spacers also holds base plug in place.

- i. Remove bolt attaching fork to strut barrel, and remove base plug and metering pin from lower strut. Remove O-rings and metering pin from base plug.

NOTE

Lower strut barrel and fork are a press fit, drilled on assembly. Separation of these

parts is not recommended, except for installation of a new part.

- j. Pull orifice piston support from upper strut. Remove O-ring and filler valve.
- k. Remove retaining ring securing steering collar to upper strut. Slide steering collar, shims, and washer from upper strut. Note number of shims between washer and steering collar.

5-38. NOSE GEAR SHOCK STRUT REASSEMBLY. (See figure 5-9.)

- a. Thoroughly clean all parts in cleaning solvent and inspect them carefully. All worn or defective parts and all O-rings and back-up rings must be replaced with new parts.
- b. Assemble the shock strut by reversing the order of the procedure outlined in paragraph 5-37 with the exception that special attention must be paid to the following procedures.
- c. Sharp metal edges should be smoothed with No. 400 emery paper, then thoroughly cleaned with solvent.
- d. Used sparingly, Dow Corning Compound DC4 is recommended for O-ring lubrication. All other internal parts should be liberally coated with hydraulic fluid during reassembly.

NOTE

Cleanliness and proper lubrication, along with careful workmanship are important during assembly of the nose gear shock strut.

e. When installing steering collar, lubricate needle bearings in collar in accordance with instructions outlined in Section 2. If needle bearing is defective, install new steering collar assembly. Use shims as required between steering collar assembly and washer to provide a snug fit with steering collar retaining ring installed. Shims of variable thickness are available from the Cessna Service Parts Center as follows:

1243030-5	0.006 inch
1243030-6	0.012 inch
1243030-7	0.020 inch

- f. When installing the rod ends in the steering collar, adjust to the dimensions shown in figure 5-9.
- g. When installing the lock ring in lower end of upper strut, position lock ring so that one of its ends covers the small access hole in the lock ring groove at the bottom of the upper strut.
- h. Temporary bolts or pins of correct diameter and length are useful tools for holding parts in correct relation to each other during assembly and installation.
- i. After assembly of shock strut, install strut in aircraft in accordance with paragraph 5-27.
- j. After installation of shock strut, fill and inflate shock strut as outlined in Section 2.

5-39. TORQUE LINKS. The torque links are illustrated in figure 5-10, which may be used as a guide for disassembly and reassembly. Torque links keep the lower strut aligned with the nose gear steering system, but permit shock strut action. Torque link

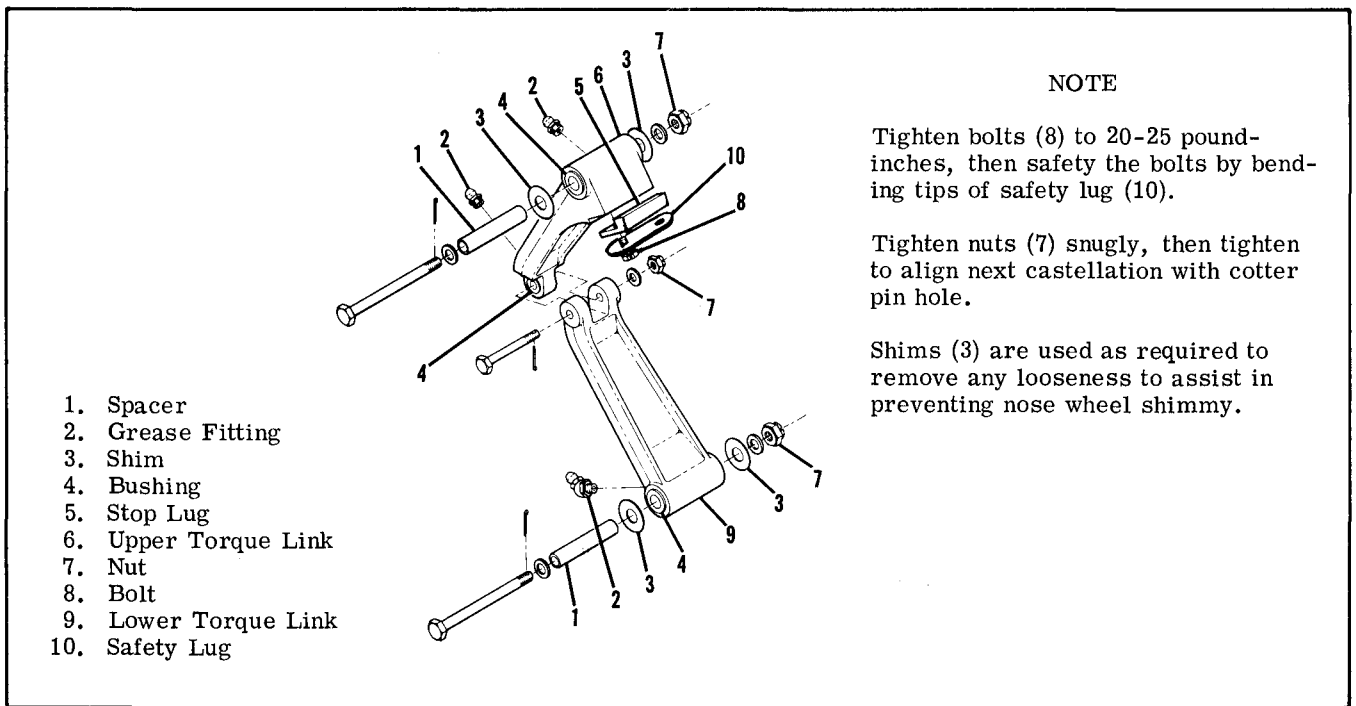

Figure 5-10. Torque Links

bushings should not be removed except for replacement of parts; replace if excessively worn. Always deflate shock strut before disconnecting torque links.

5-40. **SHIMMY DAMPENER.** The shimmy dampener provided for the nose gear offers resistance to shimmy by forcing hydraulic fluid through small orifices in a piston. The dampener piston shaft is secured to a stationary part and the housing is secured to the

nose wheel steering collar which moves as the nose wheel is turned right or left, causing relative motion between the dampener shaft and housing. The shimmy dampener is shown in figure 5-11, which may be used as a guide for disassembly and reassembly. When assembling the shimmy dampener, install new O-rings. Lubricate parts with clean hydraulic fluid during assembly. Shimmy dampener servicing procedures are outlined in Section 2.

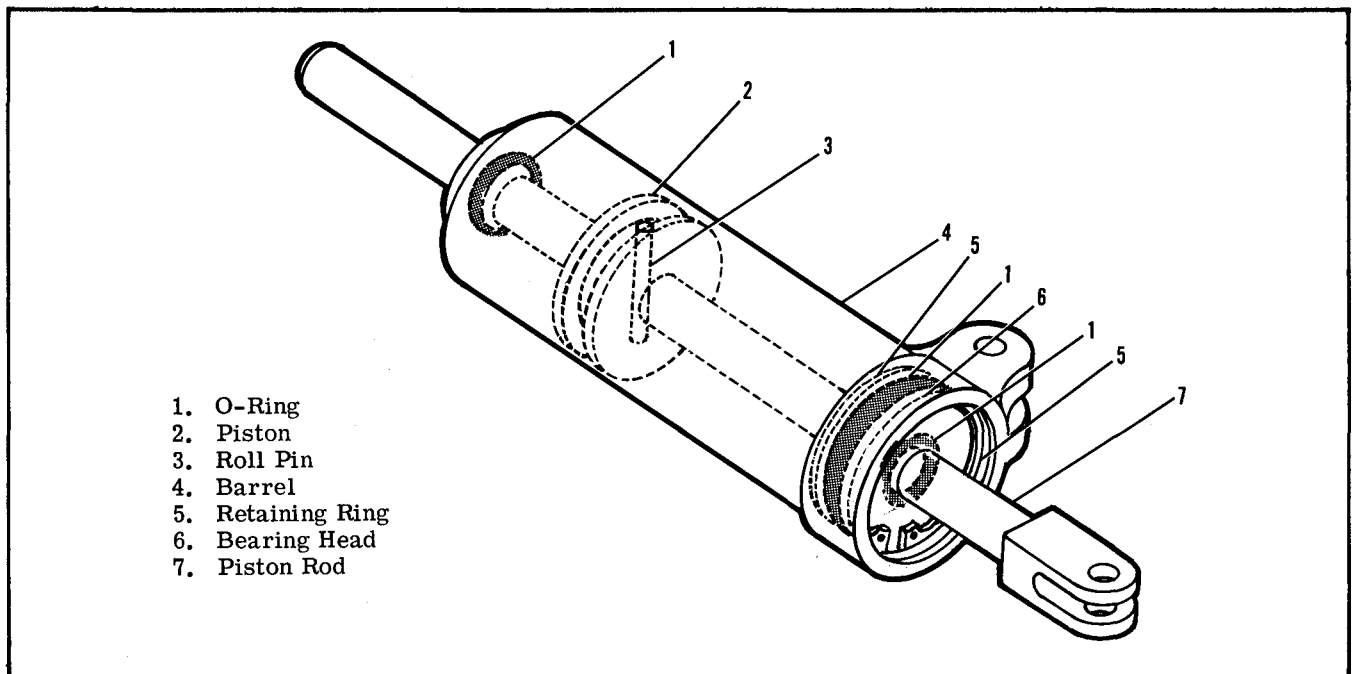

Figure 5-11. Nose Gear Shimmy Dampener

5-41. **NOSE WHEEL STEERING SYSTEM.** Nose wheel steering is accomplished through the use of the rudder pedals. Spring-loaded steering rod assemblies connect the nose gear steering collar to arms on the rudder bars. Steering is afforded up to approximately 10 degrees each side of neutral, after which brakes may be used to gain a maximum deflection of 30 degrees right or left of center. A flexible boot seals the fuselage entrance of the steering rod assembly.

5-42. **STEERING ROD ASSEMBLY.** The steering rod assembly is spring-loaded and should not be disassembled internally. The steering rods are connected by a clevis to the rod ends extending from the nose gear steering collar and to an arm on the rudder pedal crossbars.

5-43. **NOSE WHEEL STEERING ADJUSTMENT.** Since the nose wheel steering and rudder system are interconnected, adjustment to one system may affect the other system. Section 10 of this manual contains rigging instructions for the rudder system as well as the nose wheel steering system.

5-44. **BRAKE SYSTEM.**

5-45. **GENERAL DESCRIPTION.** The hydraulic brake system consists of two master cylinders, located just forward of the pilot rudder pedals, brake lines and hose connecting each master cylinder to its wheel brake cylinder, and the single-disc, floating-cylinder type brake assembly, located at each main landing gear wheel.

5-46. **TROUBLE SHOOTING.**

TROUBLE	PROBABLE CAUSE	REMEDY
DRAGGING BRAKES.	Brake pedal binding.	Check and adjust properly.
	Parking brake linkage holding brake pedal down.	Check and adjust properly.
	Worn or broken piston return spring. (In master cylinder.)	Repair or install a new cylinder.
	Insufficient clearance at Lock-O-Seal or incorrect adjustment of cylinder overall length.	Adjust as shown in figure 5-12.
	Restriction in hydraulic lines or restriction in compensating port in master brake cylinder.	Drain brake line and clear the inside of the brake line with filtered compressed air. If cleaning the lines fails to give satisfactory results, the master cylinder may be faulty and should be repaired.
	Worn, scored, or warped brake disc.	Install new disc and brake linings.
	Damaged or accumulated dirt restricting free movement of wheel brake parts.	Clean and repair or install new parts as necessary.
BRAKES FAIL TO OPERATE.	Leak in system.	If brake master cylinders or wheel cylinder assemblies are leaking, repair or install new parts.
	Air in system.	Bleed system.
	Lack of fluid in master cylinders.	Fill and bleed system.
	Master cylinder defective.	Repair or install new parts.

5-47. **BRAKE MASTER CYLINDERS.** The brake master cylinders, located just forward of the pilot rudder pedals, are actuated by applying pressure at the top of the rudder pedals. A small reservoir is incorporated into each master cylinder for the fluid supply. When dual brakes are installed, mechanical linkage permits the copilot pedals to operate the master cylinders.

5-48. **BRAKE MASTER CYLINDER REMOVAL AND INSTALLATION.**

- a. Remove bleeder screw at wheel brake assembly and drain hydraulic fluid from brake cylinders.
- b. Remove front seats and rudder bar shield for access to the brake master cylinders.
- c. Disconnect parking brake linkage and disconnect brake master cylinders from rudder pedals.
- d. Disconnect brake master cylinders at lower attach points.
- e. Disconnect hydraulic hose from brake master cylinders and remove cylinders.
- f. Plug or cap hydraulic fittings, hose and lines to prevent entry of foreign matter.
- g. Reverse the preceding steps to install brake master cylinders, then fill and bleed brake system in accordance with paragraph 5-58.

5-49. **BRAKE MASTER CYLINDER REPAIR.** Figure 5-12 may be used as a guide during disassembly, repair and reassembly of the brake master cylinders. Repair is limited to installation of new parts, cleaning, and adjustment. Use clean hydraulic fluid (MIL-H-5606) as a lubricant during assembly of the cylinders.

5-50. **HYDRAULIC BRAKE LINES** are rigid tubing, except for flexible hose used at the brake master cylinders and at the wheel brake cylinders on some models. A separate line is used to connect each brake master cylinder to its corresponding wheel brake cylinder.

5-51. **WHEEL BRAKE ASSEMBLIES.** The wheel brake assemblies use a disc which is attached to the main wheel with the wheel thru-bolts or capscrews and a floating brake assembly. (Refer to figure 5-3.)

5-52. **WHEEL BRAKES REMOVAL.** Wheel brake assemblies can be removed by disconnecting the brake hose and removing the brake back plate. See figure 5-3 for brake assembly affected. The brake disc is removed after the wheel is removed and disassembled. To remove the torque plate, remove wheel and axle or wheel only as outlined in applicable paragraphs in this Section. Refer to figure 5-3 for disassembly of either wheel brake assembly.

5-53. **WHEEL BRAKE INSPECTION AND REPAIR.**

- a. Clean all parts except brake linings and O-rings in dry cleaning solvent and dry thoroughly.
- b. New O-rings are usually installed at each time they are removed. If O-ring re-use is necessary, they should be wiped with a clean cloth saturated in hydraulic fluid and inspected for damage.

NOTE

Thorough cleaning is important. Dirt and chips are the greatest single cause of malfunctions in the hydraulic brake system.

- c. Check brake lining for deterioration and maximum permissible wear. See paragraph 5-56.
- d. Inspect brake cylinder bore for scoring. A scored cylinder will leak or cause rapid O-ring wear. Install new brake cylinder.
- e. If the anchor bolts on the brake assembly are nicked or gouged, they shall be sanded smooth to prevent binding with the pressure plate or torque plate. When new anchor bolts are to be installed, press out old bolts and drive bolts in with a soft mallet.
- f. Inspect wheel brake disc for a minimum thickness of 0.190-inch. If brake disc is below minimum thickness, install a new part.

5-54. **WHEEL BRAKE REASSEMBLY.** Lubricate parts with clean hydraulic fluid and assemble components with care to prevent damage to O-rings. Refer to figure 5-3 during assembly of wheel brakes.

5-55. **WHEEL BRAKE INSTALLATION.** Place brake assembly in position with pressure plate in place, then install back plate. If torque plate was removed, install as the axle is installed or install on axle. If the brake disc was removed from the wheel, install as wheel is assembled.

5-56. **CHECKING BRAKE LINING WEAR.** New brake lining should be installed when they are worn to a minimum thickness of 3/32-inch. Visually compare a 3/32-inch strip of material held adjacent to each lining to measure the thickness of the lining. The shank end of correct size drill bit makes an excellent tool for checking minimum thickness of the brake linings.

5-57. **BRAKE LINING INSTALLATION.** (See figure 5-3.)

- a. Remove bolts securing back plate and remove back plate.
- b. Pull the brake cylinder out of torque plate and slide pressure plate off anchor bolts.
- c. Place back plate on a table with lining side down flat. Center a 9/64-inch (or slightly smaller) punch in the rolled rivet, and hit the punch sharply with a hammer. Punch out all rivets securing the linings to the back plate and pressure plate in the same manner.

NOTE

A rivet setting kit, Part No. R561, is available from the Cessna Service Parts Center. This kit consists of an anvil and punch.

- d. Clamp the flat side of the anvil in a vise.

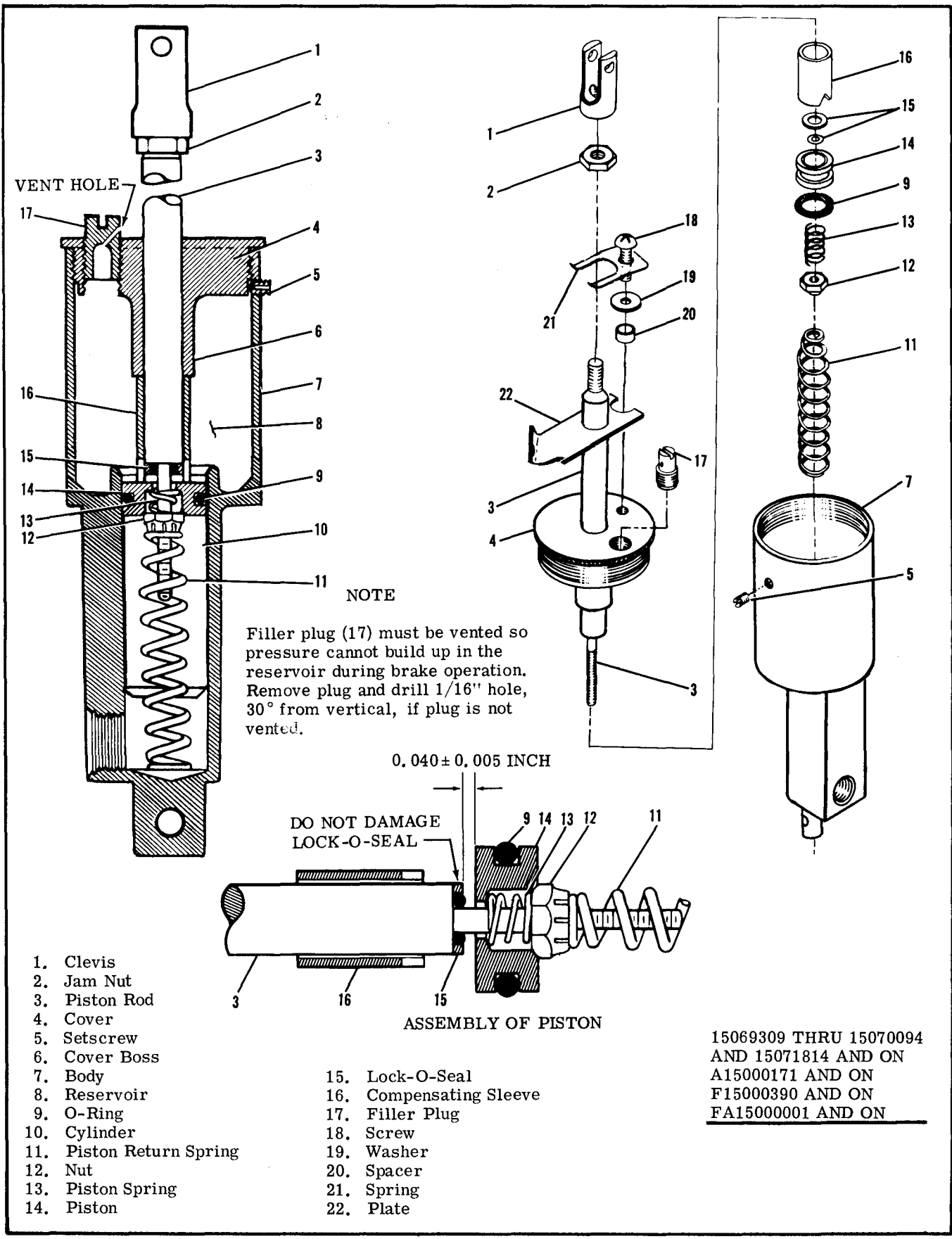

- 1. Clevis
- 2. Jam Nut
- 3. Piston Rod
- 4. Cover
- 5. Setscrew
- 6. Cover Boss
- 7. Body
- 8. Reservoir
- 9. O-Ring
- 10. Cylinder
- 11. Piston Return Spring
- 12. Nut
- 13. Piston Spring
- 14. Piston

- 15. Lock-O-Seal
- 16. Compensating Sleeve
- 17. Filler Plug
- 18. Screw
- 19. Washer
- 20. Spacer
- 21. Spring
- 22. Plate

Figure 5-12. Brake Master Cylinder (Sheet 1 of 2)

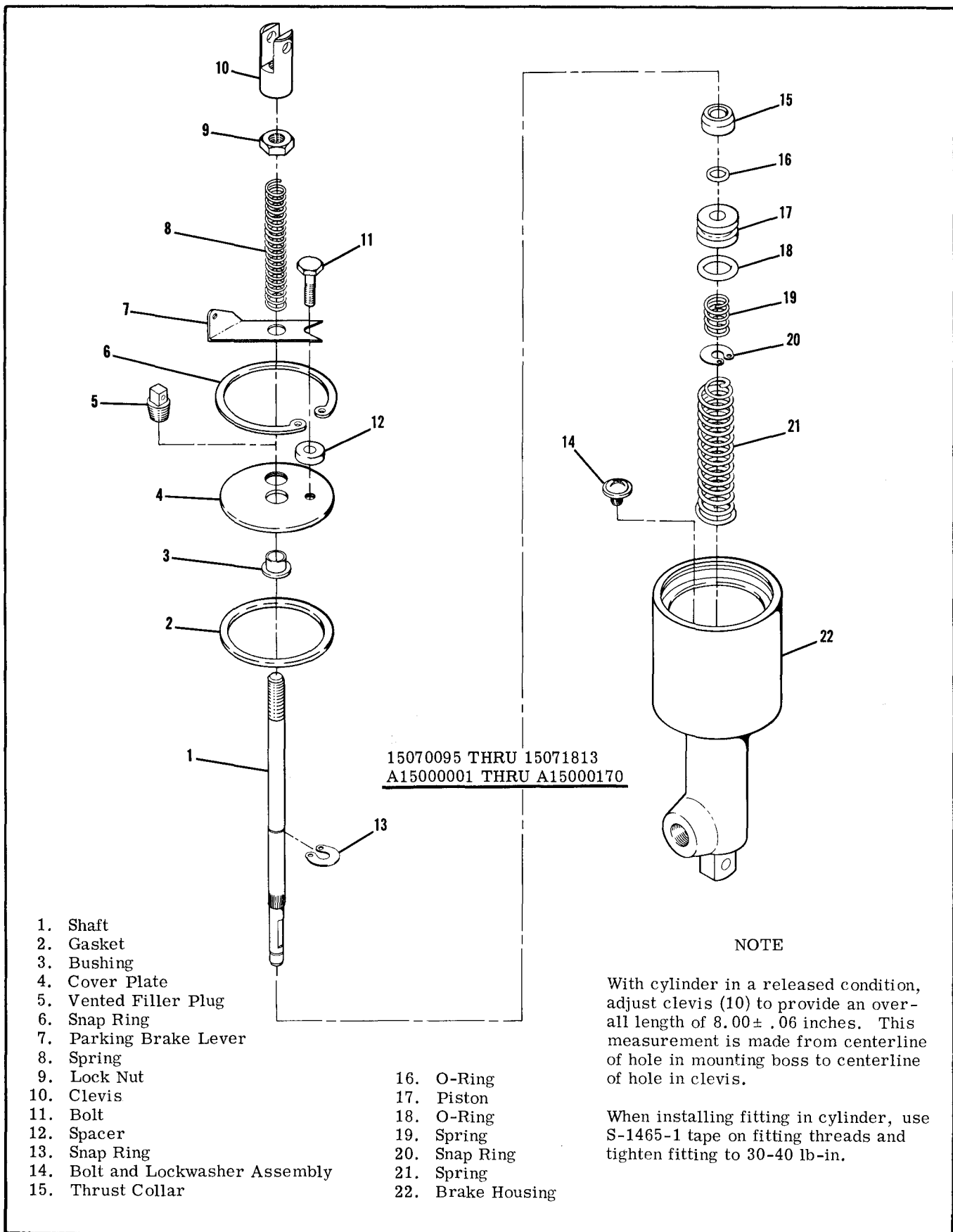

- | | |
|----------------------------------|-------------------|
| 1. Shaft | 16. O-Ring |
| 2. Gasket | 17. Piston |
| 3. Bushing | 18. O-Ring |
| 4. Cover Plate | 19. Spring |
| 5. Vented Filler Plug | 20. Snap Ring |
| 6. Snap Ring | 21. Spring |
| 7. Parking Brake Lever | 22. Brake Housing |
| 8. Spring | |
| 9. Lock Nut | |
| 10. Clevis | |
| 11. Bolt | |
| 12. Spacer | |
| 13. Snap Ring | |
| 14. Bolt and Lockwasher Assembly | |
| 15. Thrust Collar | |

Figure 5-12. Brake Master Cylinder (Sheet 2 of 2)

e. Align new lining on back plate and place brake rivet in hole with rivet head in the lining. Place the head against the anvil.

f. Center the rivet setting punch on the lips of the rivet. While holding the back plate down firmly against the lining, hit punch with a hammer to set the rivet. Repeat blows on the punch until lining is firmly against back plate.

g. Realign the lining on the back plate and install and set rivets in the remaining holes.

h. Install a new lining on pressure plate in the same manner.

i. Position pressure plate on anchor bolts and place cylinder in position so that anchor bolts slide into the torque plate.

j. Install back plate with bolts and washers.

5-58. BRAKE SYSTEM BLEEDING. Bleeding with a clean hydraulic pressure source connected to the wheel cylinder bleeder is recommended.

a. Remove brake master cylinder filler plug and screw flexible hose with appropriate fitting into the filler hole at top of the master cylinder. Immerse the free end of the flexible hose in a container with enough hydraulic fluid to cover the end of the hose.

b. Connect a clean hydraulic pressure source, such

as a hydraulic hand pump or Hydro Fill unit, to the bleeder valve in the wheel cylinder.

c. As fluid is pumped into the system, observe the immersed end of the hose at the master brake cylinder for evidence of air bubbles being forced from the brake system. When bubbling has ceased, remove bleeder source from wheel cylinder and tighten the bleeder valve.

NOTE

Ensure that the free end of the hose from the master cylinder remains immersed during the entire bleeding process.

5-59. PARKING BRAKE SYSTEM. (See figure 5-13.) The parking brake system consists of a control knob on the instrument panel which is connected to linkage at the master brake cylinders. At the brake master cylinders, the control operates locking plates which trap pressure in the system after the master cylinder piston rods have been depressed by toe-operation of the rudder pedals. To release the parking brake, depress the pedals and push the control knob full in.

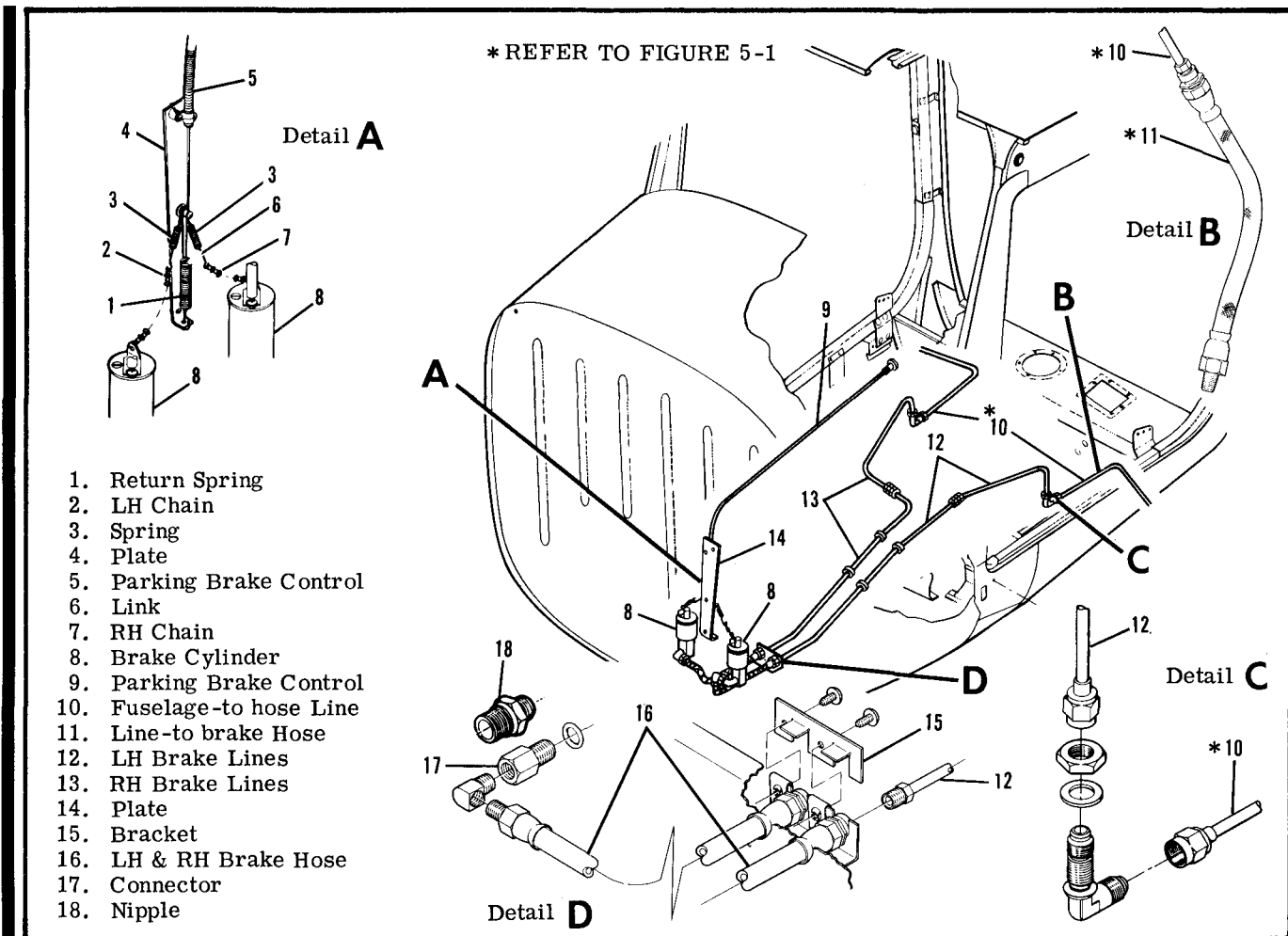

Figure 5-13. Brake Systems

SECTION 6

AILERON CONTROL SYSTEM

TABLE OF CONTENTS	Page		
AILERON CONTROL SYSTEM	6-1	Installation	6-5
Description	6-1	Cables and Pulleys	6-6
Trouble Shooting	6-1	Removal and Installation	6-6
Control "Y"	6-2	Ailerons	6-6
Description	6-2	Removal	6-6
Removal and Installation	6-2	Installation	6-6
Aileron Bellcrank	6-5	Rigging	6-6
Removal	6-5		

6-1. AILERON CONTROL SYSTEM. (Refer to figure 6-1.)

pulleys, sprockets and roller chains, all of which, link the control wheels to the ailerons. A control "Y" interconnects the control wheels to the aileron cables.

6-2. DESCRIPTION. The aileron control system is comprised of push-pull rods, bellcranks, cables,

6-3. TROUBLE SHOOTING.

NOTE

Due to remedy procedures in the following trouble shooting chart it may be necessary to re-rig system, refer to paragraph 6-15.

TROUBLE	PROBABLE CAUSE	REMEDY
LOST MOTION IN CONTROL WHEELS.	Loose control cables.	Adjust cables to proper tension.
	Broken pulley or bracket, cable off pulley or worn rod end bearings.	Replace worn or broken parts, install cables correctly.
	Sprung bellcrank.	Replace bellcrank.
	Loose chains.	Adjust chain tension.

6-3. TROUBLE SHOOTING (Cont).

TROUBLE	PROBABLE CAUSE	REMEDY
RESISTANCE TO CONTROL WHEEL MOVEMENT.	Cables too tight.	Adjust cables to proper tension.
	Pulleys binding or cable off.	Replace defective pulleys. Install cables correctly.
	Bellcrank distorted or damaged.	Replace bellcrank.
	Defective U-joints.	Replace defective U-joints.
	Clevis bolts in system too tight.	Loosen, then tighten properly and safety.
	Rusty chain or chain binding with sprocket.	Replace chain or defective parts.
CONTROL WHEELS NOT LEVEL WITH AILERONS NEUTRAL.	Improper adjustment of chains or cables.	Adjust in accordance with paragraph 6-15.
	Improper adjustment of aileron push-pull rods.	Adjust in accordance with paragraph 6-15.
DUAL CONTROL WHEELS NOT COORDINATED.	Chains improperly adjusted.	Adjust in accordance with paragraph 6-15.
INCORRECT AILERON TRAVEL.	Push-pull rods not adjusted properly.	Adjust in accordance with paragraph 6-15.
	Worn bellcrank stop bushings on bellcrank slots.	Replace worn parts.

6-4. CONTROL "Y". (Refer to figure 6-2.)

6-5. DESCRIPTION. The control "Y" transforms rotation of the control wheels into pulling motion on the aileron cables by means of sprockets and chains. The "Y" is pivoted at the lower end to operate the elevator control system.

6-6. REMOVAL AND INSTALLATION.

a. Remove control cover and carpeting as necessary to gain access to lower end of control "Y".

b. Release cable tension by loosening turnbuckle (index 3, figure 6-1).

c. Remove bolt (17) attaching control link (14).

d. Remove bolts (8) securing control wheel tubes (9) to universal joints (7).

e. Remove bolts securing cable ends to control arm (5).

f. Remove pivot bolt (16) and remove control "Y".

g. Reverse preceding steps for installation.
 h. Rig aileron system in accordance with applicable paragraph in this section, safety turnbuckle and re-install all items removed in step "a".

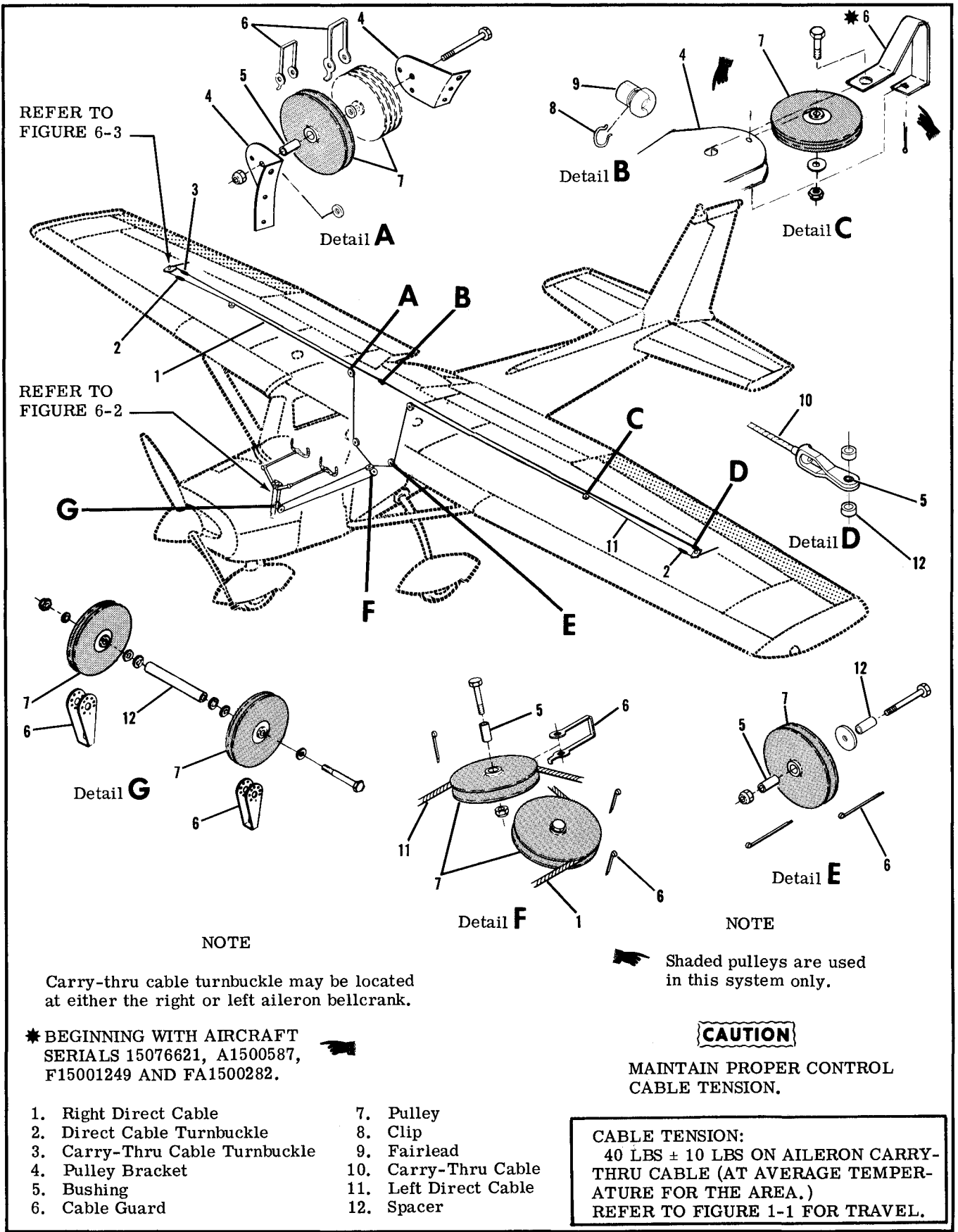

REFER TO
FIGURE 6-3

REFER TO
FIGURE 6-2

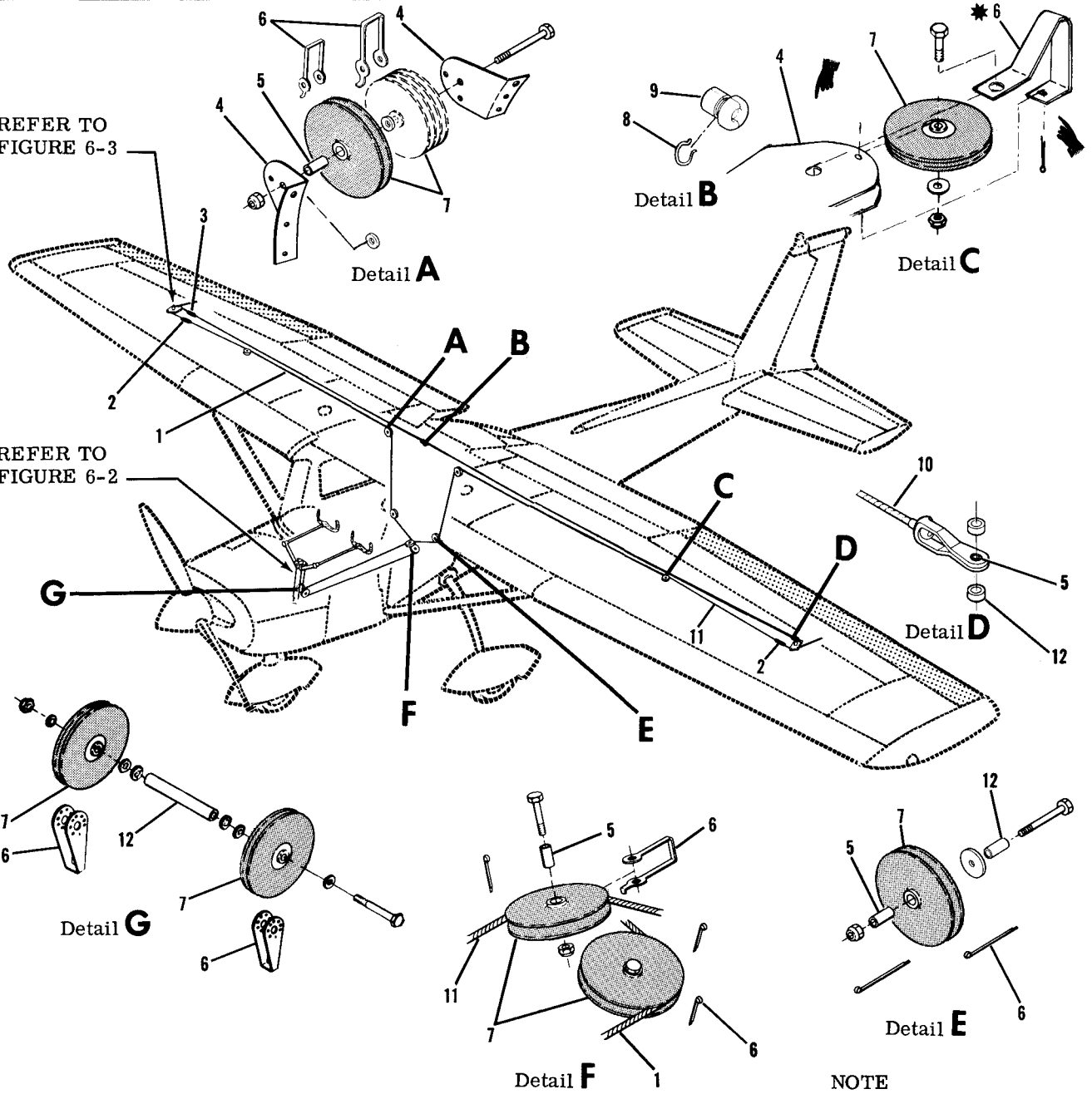

NOTE

Carry-thru cable turnbuckle may be located at either the right or left aileron bellcrank.

* BEGINNING WITH AIRCRAFT SERIALS 15076621, A1500587, F15001249 AND FA1500282.

- | | |
|--------------------------------|-----------------------|
| 1. Right Direct Cable | 7. Pulley |
| 2. Direct Cable Turnbuckle | 8. Clip |
| 3. Carry-Thru Cable Turnbuckle | 9. Fairlead |
| 4. Pulley Bracket | 10. Carry-Thru Cable |
| 5. Bushing | 11. Left Direct Cable |
| 6. Cable Guard | 12. Spacer |

NOTE

Shaded pulleys are used in this system only.

CAUTION

MAINTAIN PROPER CONTROL CABLE TENSION.

CABLE TENSION:
40 LBS ± 10 LBS ON AILERON CARRY-THRU CABLE (AT AVERAGE TEMPERATURE FOR THE AREA.)
REFER TO FIGURE 1-1 FOR TRAVEL.

Figure 6-1. Aileron Control System

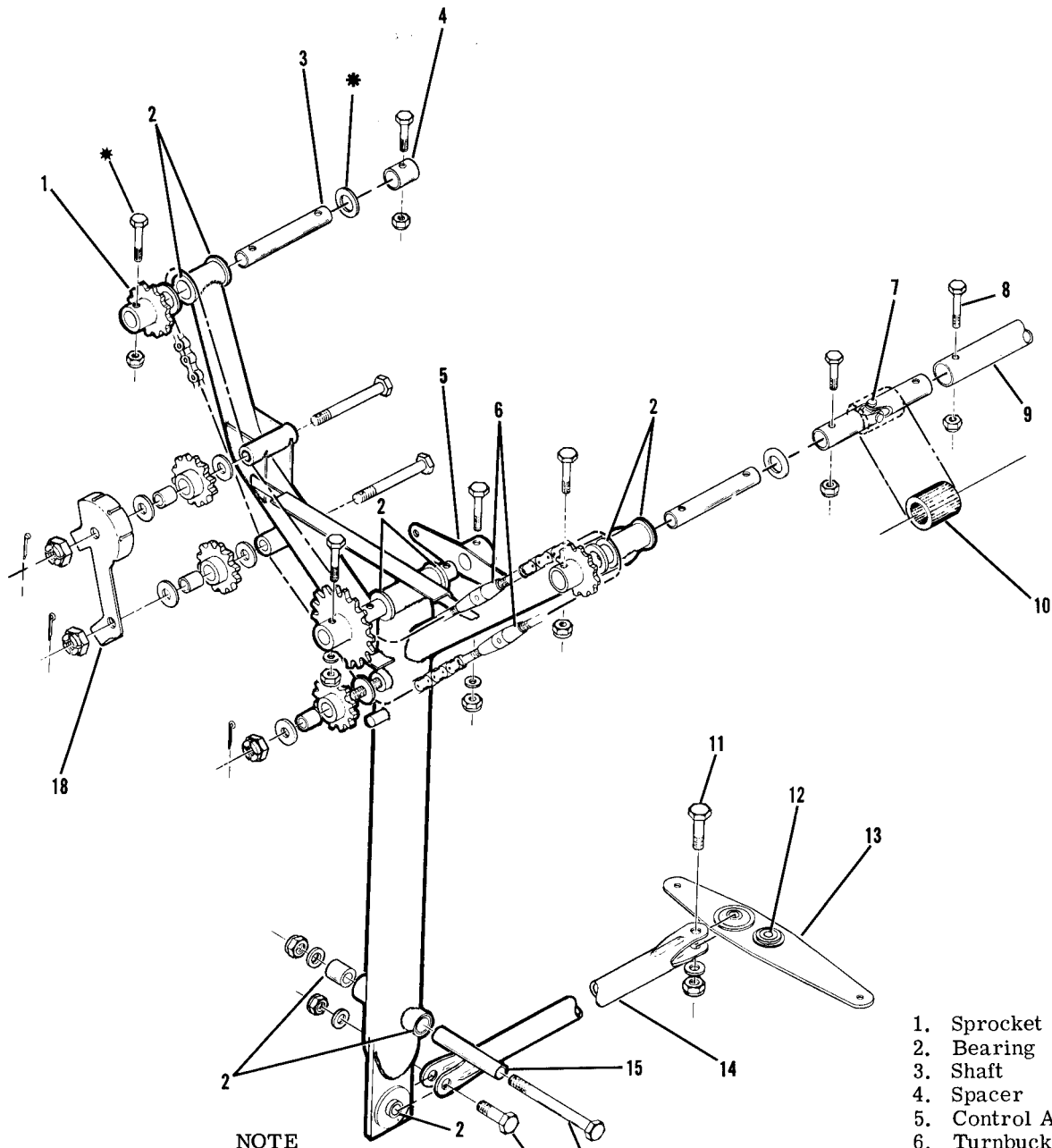

NOTE

When dual controls are installed, spacer (4) is replaced with a universal joint to which the right control wheel is attached.

Chains are to have minimum amount of tension which will remove slack from chains.

* Use as required for maximum .005 inch end play per side.

* Left and right bolts are to be parallel.

- 1. Sprocket
- 2. Bearing
- 3. Shaft
- 4. Spacer
- 5. Control Arm
- 6. Turnbuckle
- 7. Universal Joint
- 8. Bolt
- 9. Control Wheel Tube
- 10. Cover
- 11. Bolt
- 12. Bearing
- 13. Bellcrank
- 14. Control Link
- 15. Bushing
- 16. Pivot Bolt
- 17. Bolt
- 18. Chain Guard

Figure 6-2. Control "Y" Installation

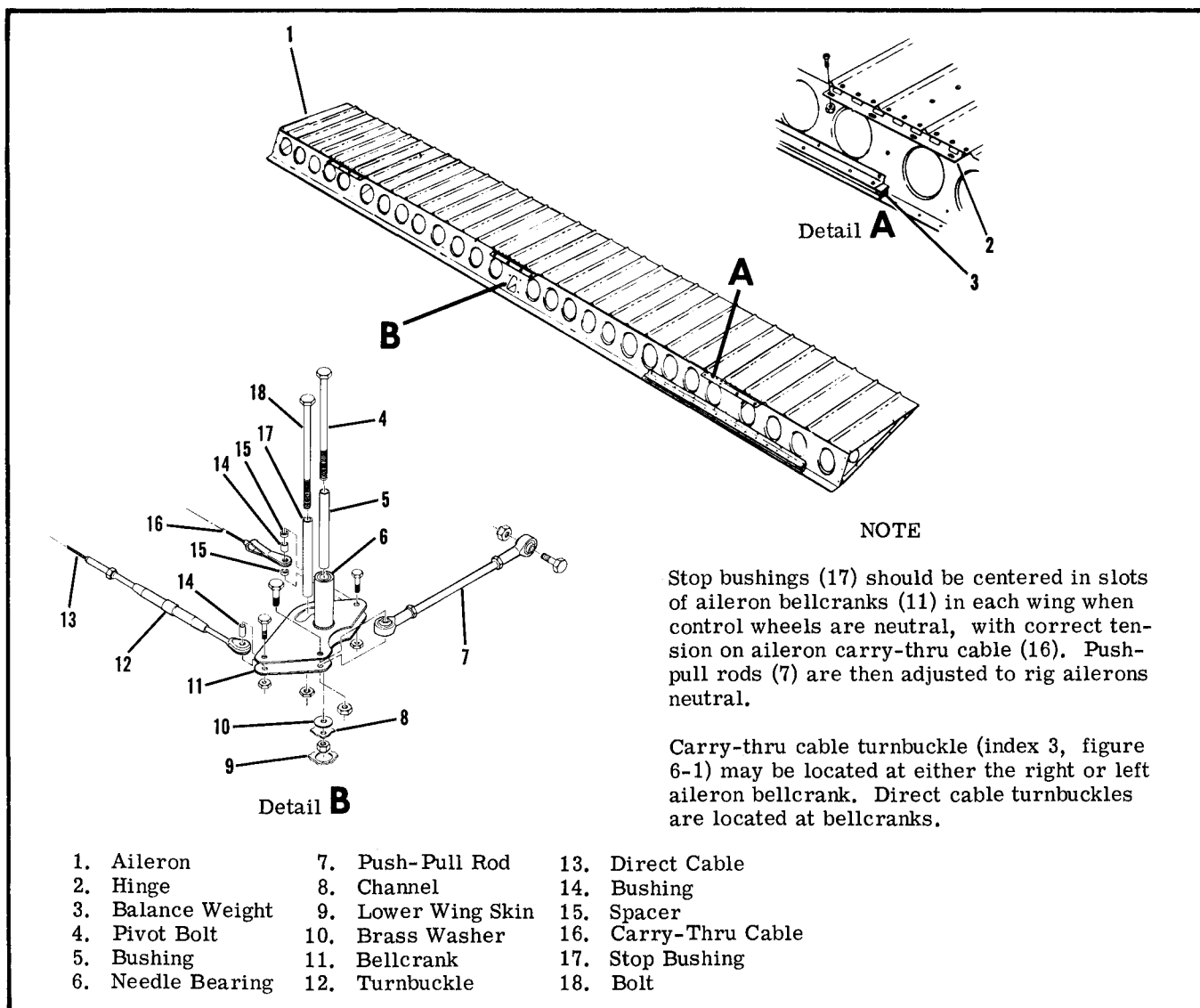

Figure 6-3. Aileron and Bellcrank Installation

i. Check and/or rig elevator control system in accordance with applicable paragraph in Section 8.

6-7. AILERON BELLCRANK. (Refer to figure 6-3.)

6-8. REMOVAL.

- a. Remove access plate inboard of each bellcrank on underside of wing.
- b. Relieve control cable tension by loosening turnbuckle barrel (index 3, figure 6-1).
- c. Disconnect control cables from bellcrank. Retain all spacers (15).
- d. Disconnect aileron push-pull rod (7) at bellcrank.
- e. Remove nut, washer and bolt securing bellcrank stop bushing (17) and bellcrank (11) to wing structure.
- f. Remove bellcrank through access opening, using care bushing (5) is not dropped from bellcrank.

NOTE

Brass washers (10) may be used as shims between lower end of bellcrank and wing channel (8). Retain these shims. Tape open ends of bellcrank to prevent dust and dirt from entering bellcrank needle bearings (6).

6-9. INSTALLATION.

- a. Place bushing (5) and stop-bushing (17) in bellcrank and position bellcrank in wing.
- b. Install brass washers (10) between lower end of bellcrank and wing channel (8) to shim out excess clearance.
- c. Install bellcrank pivot bolt (4), washers and nut.
- d. Position bellcrank stop-bushing (17) and install attaching bolt (18), washers and nut.

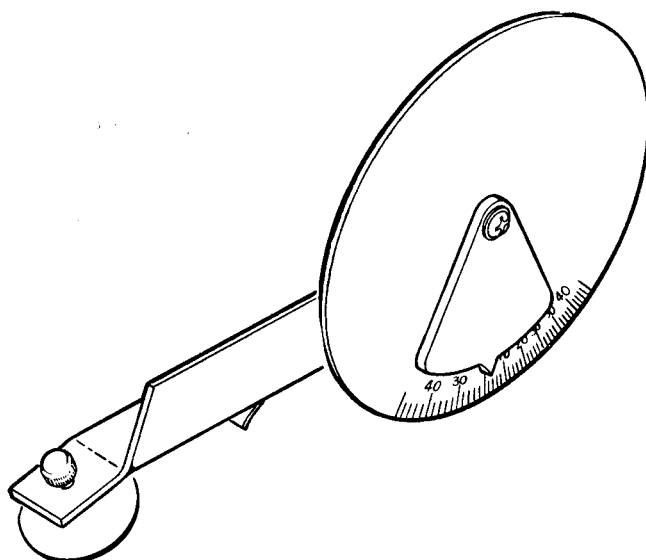

AVAILABLE FROM CESSNA SERVICE PARTS CENTER (TOOL NO. SE 716)

Figure 6-4. Inclinometer for Measuring Control Surface Travel

- e. Connect aileron cables to bellcrank.
- f. Rig aileron system in accordance with applicable paragraph in this section, safety turnbuckle and install access plates.

6-10. CABLES AND PULLEYS. (Refer to figure 6-1.)

6-11. REMOVAL AND INSTALLATION.

- a. Remove access plates, wing root fairings and upholstery as required.
- b. Disconnect cables from aileron bellcranks and remove cable guards and pulleys as necessary to work cables free of aircraft.

NOTE

To ease routing of cables, a length of wire may be attached to end of cable before being withdrawn from aircraft. Leave wire in place, routed through structure; then attach to cable being installed and use to pull cable into position.

- c. After cable is routed, install pulleys and cable guards. Ensure cable is positioned in pulley groove before installing guard.
- d. Rig aileron system in accordance with applicable paragraph in this section, safety turnbuckles and install access plates, fairings and upholstery removed in step "a."

6-12. AILERONS. (Refer to figure 6-3.)

6-13. REMOVAL.

- a. Disconnect push-pull rod (7) at aileron.

- b. Remove screws and nuts attaching aileron hinges (2) to trailing edge of wing.
- c. Using care, pull aileron out and down to slide hinges from under wing skin and auxiliary spar reinforcements.

6-14. INSTALLATION.

- a. Position aileron hinges between skin and auxiliary spar reinforcements and install screws and nuts attaching hinges to trailing edge of wing.
- b. Attach push-pull rod to aileron.

NOTE

If rigging was correct and push-pull rod adjustment was not disturbed, it should not be necessary to rig system.

- c. Check aileron travel and alignment, rig if necessary, in accordance with applicable paragraph in this section.

6-15. RIGGING.

- a. (Refer to figure 6-2.) Position arm (5) horizontal and install chain with an equal number of links extending from central drive sprocket on arm (5).
- b. Adjust turnbuckles (6) to remove slack from chain and synchronize control wheels (level).

NOTE

Adjust chain turnbuckles (6) to minimum tension required to remove slack.

- c. Tape a bar across both control wheels to hold them in neutral position.

d. (Refer to figure 6-3.) Adjust turnbuckles at bellcranks (11) so stop bushings (17) are centered in bellcrank slots with 40 ± 10 pounds tension on carry-thru cable (16). Disregard tension on direct cables, which will be different than tension on carry-thru cable.

e. Adjust push-pull rod (7) at each aileron until ailerons are neutral with reference to the trailing edge of wing flaps. Be sure wing flaps are fully up when making this adjustment. Tighten push-pull rod jam nuts.

f. Safety all turnbuckles by the single-wrap method using 0.040-inch monel safety wire.

g. Remove bar from control wheels and install all parts removed for access.

h. Check ailerons for correct travel, using inclinometer shown in figure 6-4.

WARNING

Be sure ailerons move in correct direction when operated by control wheel.

SHOP NOTES:

This page intentionally left blank.

SECTION 7

WING FLAP CONTROL SYSTEM

TABLE OF CONTENTS	Page		
WING FLAP CONTROL SYSTEM	7-1	Flaps	7-4
Description	7-1	Removal and Installation	7-4
Operational Check	7-1	Repair	7-4
Trouble Shooting	7-2	Cables and Pulleys	7-4
Flap Motor and Transmission Assembly	7-4	Removal and Installation	7-4
Removal and Installation	7-4	Rigging	7-9
Repair	7-4	Indicating System	7-11
Drive Pulleys	7-4	Description	7-11
Removal and Installation	7-4	Rigging	7-11
Repair	7-4		

7-1. WING FLAP CONTROL SYSTEM. (Refer to figure 7-1.)

7-2. DESCRIPTION. The wing flap control system is comprised of an electric motor and transmission assembly, drive pulleys, push-pull rods, cables, pulleys and a flap position indicator. Power from the motor and transmission assembly is transmitted to the flaps by a system of drive pulleys, cables and push-pull rods. Electrical power to the motor is controlled by a 3-position switch mounted on the instrument panel. The flap position indicator is calibrated to show degrees of extension.

7-3. OPERATIONAL CHECK.

a. Operate flaps through their full range of travel, observing for uneven or jumpy motion, binding and lost motion in system. Ensure flaps are moving together through their full range of travel.

b. THRU AIRCRAFT SERIALS 15072629, F15000738, A15000277 AND FA15000132 WHEN NOT MODIFIED IN ACCORDANCE WITH FIGURE 7-2, SHEET 3. Attempt to overrun travel extremes and check for transmission freewheeling at flaps extended position. Check up-limit switch actuation at flaps retracted position.

c. BEGINNING WITH AIRCRAFT SERIALS 15072630, F15000739, A15000278, FA15000133 AND ALL AIR-

CRAFT MODIFIED IN ACCORDANCE WITH FIGURE 7-2, SHEET 3. Check for positive sheet off of motor at the flap travel extremes, **FLAP MOTOR MUST STOP OR DAMAGE WILL RESULT.**

d. Check flaps for sluggishness in operation. In flight at 100 mph, indicated airspeed, flaps should fully extend in approximately 9 seconds and retract in approximately 5 seconds. On the ground, with engine running, the flaps should extend or retract in approximately 6 seconds.

e. With flaps full UP, mount an inclinometer on one flap and set to 0°. Lower flaps to full DOWN position and check flap angle as specified in figure 1-1. Check approximate mid-range percentage setting against degrees as indicated on inclinometer. Repeat the same procedure for the opposite flap.

NOTE

An inclinometer for measuring control surface travel is available from the Cessna Service Parts Center. Refer to figure 6-4.

f. Remove access plates adjacent to flap drive pulleys and attempt to rock pulleys to check for bearing wear.

g. Inspect flap rollers and tracks for evidence of binding or defective parts.

7-4. TROUBLE SHOOTING.

NOTE

Due to remedy procedures in the following trouble shooting chart it may be necessary to re-rig system, refer to paragraphs 7-16 and 7-19.

TROUBLE	PROBABLE CAUSE	REMEDY
BOTH FLAPS FAIL TO MOVE.	Blown fuse.	Check visually. Replace fuse.
	Defective switch.	Place jumper across switch. Replace if defective.
	Defective motor.	Remove and bench test motor. Replace if defective.
	Broken or disconnected wires.	Run a continuity check. Connect or repair wiring.
	Defective or disconnected transmission.	Connect or replace transmission.
	Defective limit switch.	Check continuity of switches. Replace switches found defective.
BINDING IN SYSTEM AS FLAPS ARE RAISED AND LOWERED.	Cables not riding on pulleys.	Check visually. Route cables correctly over pulleys.
	Bind in drive pulleys.	Check drive pulleys in motion. Replace drive pulleys found defective.
	Broken or binding pulleys.	Check pulleys for free rotation or breaks. Replace defective pulleys.
	Frayed cable.	Check visually. Replace defective cable.
	Flaps binding on tracks.	Observe flap tracks and rollers. Replace defective parts.
LEFT FLAP FAILS TO MOVE.	Disconnected or broken cable.	Check cable tension. Connect or replace cable.
	Disconnected push-pull rod.	Check visually. Attach push-pull rod.
INCORRECT FLAP TRAVEL.	Incorrect rigging.	Refer to paragraph 7-16.
	Defective limit switch.	Check continuity of switches. Replace switches found defective.
FLAPS FAIL TO RETRACT.	Defective or disconnected UP-LIMIT switch.	Check continuity of switch. Connect or replace limit switch.
FLAPS FAIL TO EXTEND.	Defective or disconnected DOWN-LIMIT switch.	Check continuity of switch. Connect or replace limit switch.

THRU AIRCRAFT SERIALS
15074399, A15000387, F150-
00943 AND FA15000211

REFER TO FIGURE 7-2

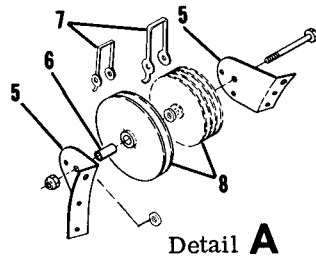
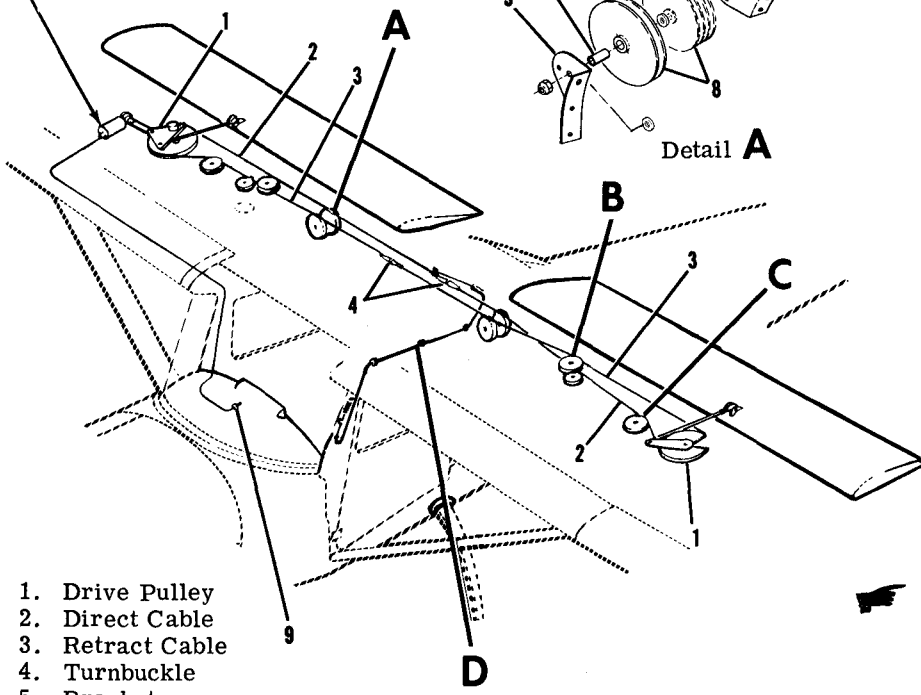

Detail A

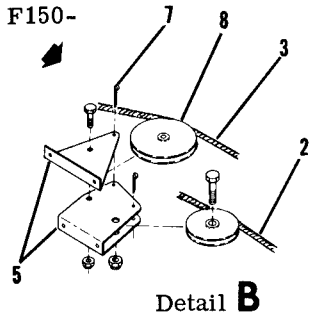

Detail B

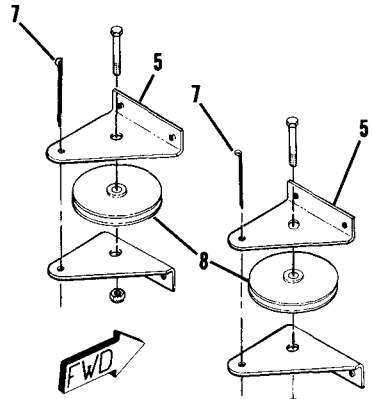

Detail B

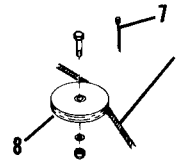

Detail C

BEGINNING WITH AIRCRAFT
SERIALS 15074400, A15000388,
F15000944 AND FA15000212

1. Drive Pulley
2. Direct Cable
3. Retract Cable
4. Turnbuckle
5. Bracket
6. Bushing
7. Cable Guard
8. Pulley
9. Switch
10. Clamp
11. Wire
12. Tubing
13. Support Clamp
14. Trim
15. Indicator Pointer
16. Spring

NOTES

- Secure wire (11) by wrapping around screw two times.
- *Lubricate wire (11) in accordance with Section 2.

CAUTION

MAINTAIN PROPER CONTROL
CABLE TENSION.

CABLE TENSION:
30 LBS ± 10 LBS (AT AVERAGE TEMPER-
ATURE FOR THE AREA.)
REFER TO FIGURE 1-1 FOR TRAVELS.

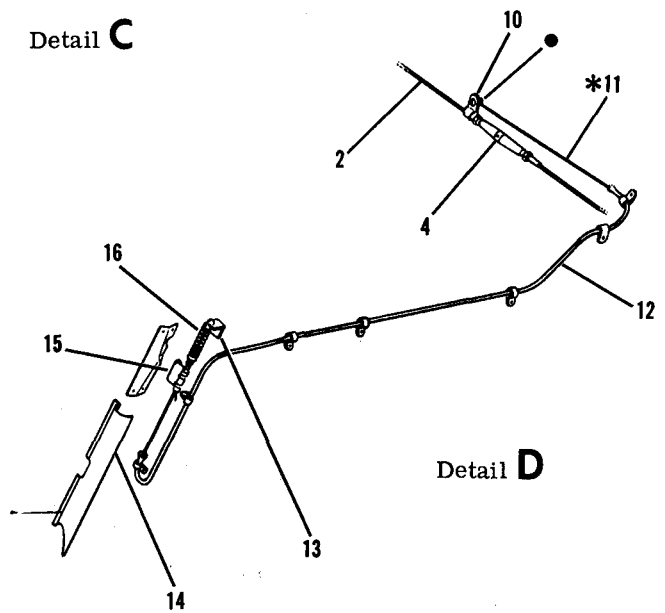

Detail D

Figure 7-1. Wing Flap Control System

7-5. FLAP MOTOR AND TRANSMISSION ASSEMBLY.

7-6. REMOVAL AND INSTALLATION.

a. THRU AIRCRAFT SERIALS 15072629, F15000738, A15000277 AND FA15000132 WHEN NOT MODIFIED IN ACCORDANCE WITH SK150-37 AND WHEN NOT MODIFIED IN ACCORDANCE WITH FIGURE 7-2, SHEET 3. (Refer to figure 7-2, sheet 1.)

1. Run flaps to full DOWN position.
2. Disconnect battery cables at the battery and insulate cable terminals as a safety precaution.
3. Remove access plates adjacent to drive pulley and motor assembly on right wing.

NOTE

Remove motor (10), transmission (8), hinge assembly (11) and actuating tube (5) from aircraft as a unit.

4. Remove bolt (21) securing actuating tube (5) to drive pulley (14).
5. Screw actuating tube (5) IN toward transmission (8) by hand to its shortest length.
6. Remove bolt (1) securing flap motor hinge (11) to wing. Retain brass washer between hinge and wing structure for use on reinstallation.
7. Disconnect motor electrical wiring (9) at quick-disconnects.
8. Disconnect electrical wiring at up-limit switch (3).
9. Using care, work assembly from wing through access opening.
10. Reverse the preceding steps for reinstallation. If the hinge assembly (11) was removed from the transmission (8) for any reason, ensure the short end of hinge is reinstalled toward the top.

11. Complete an operational check as outlined in paragraph 7-3 and re-rig system in accordance with paragraph 7-16.

b. THRU AIRCRAFT SERIALS 15072629, F15000738, A15000277 AND FA15000132 WHEN MODIFIED IN ACCORDANCE WITH SK150-37 AND WHEN NOT MODIFIED IN ACCORDANCE WITH FIGURE 7-2, SHEET 3. (Refer to figure 7-2, sheet 2.)

1. Complete steps 1, 3 and 4 of subparagraph "a."
 2. Run flap motor to place actuating tube (5) IN to its shortest length.
 3. Complete steps 2, 6, 7, 8, 9, 10 and 11 of subparagraph "a."
- c. BEGINNING WITH AIRCRAFT SERIALS 15072630, F15000739, A15000278, FA15000133 AND ALL AIRCRAFT MODIFIED IN ACCORDANCE WITH FIGURE 7-2, SHEET 3. (Refer to figure 7-2, sheets 2 and 3.)
1. Complete steps 1 thru 7 of subparagraph "a."
 2. Disconnect electrical wiring at limit switches (29 and 32). Tag wires for reference or reinstallation.
 3. Complete steps 9 thru 11 of subparagraph "a."

7-7. REPAIR. Repair consists of replacement of motor, transmission, coupling, actuating tube and associated hardware. Bearings in hinge assembly may also be replaced. Lubricate as outlined in Section 2.

7-8. DRIVE PULLEYS. (Refer to figure 7-2.)

7-9. REMOVAL AND INSTALLATION.

- a. Remove access plate adjacent to drive pulley (14) in right wing.
- b. Unzip or remove headliner as necessary for access to turnbuckles (index 4, figure 7-1), remove safety wire and loosen turnbuckles.
- c. Remove bolt (20) securing flap push-pull rod (15) to drive pulley (14) and lower RIGHT flap gently.
- d. Remove bolt (21) securing actuating tube (5) to drive pulley (14) and lower LEFT flap gently. Retain bushing.
- e. Remove cable locks (13) securing control cables to drive pulley (14). Tag cables for reference on reinstallation.
- f. Remove bolt (12) attaching drive pulley (14) to wing structure.
- g. Using care, remove drive pulley through access opening, being careful not to drop bushing. Retain brass washer between drive pulley and wing structure for use on reinstallation. Tape open ends of drive pulley after removal to protect bearings.
- h. To remove left wing drive pulley, use this same procedure omitting step "d."
- i. Reverse the preceding steps for reinstallation. Rig system in accordance with paragraph 7-16, safety turnbuckles and reinstall all items removed for access.

7-10. REPAIR. Repair is limited to replacement of bearings. Cracked, bent or excessively worn drive pulleys must be replaced. Lubricate bearings as outlined in Section 2.

7-11. FLAPS. (Refer to figure 7-3.)

7-12. REMOVAL AND INSTALLATION.

- a. Run flaps to full DOWN position.
- b. Remove access plates (1) from top leading edge of flap.
- c. Disconnect push-pull rod (6) at flap bracket (7).
- d. Remove bolts (5) at each flap track. As flap is removed from wing, all washers, rollers and bushings will fall free. Retain these for reinstallation.
- e. Reverse the preceding steps for reinstallation. If push-pull rod (6) adjustment is not disturbed, re-rigging of system should not be necessary. Check flap travel and rig in accordance with paragraph 7-16, if necessary.

7-13. REPAIR. Flap repair may be accomplished in accordance with instructions outlined in Section 18.

7-14. CABLES AND PULLEYS. (Refer to figure 7-1.)

7-15. REMOVAL AND INSTALLATION.

- a. Remove access plates, fairings, headliner and upholstery as necessary for access.
- b. If the direct cable (2) is to be removed, disconnect clamp (10) and slowly release indicator wire (11) until spring (16) tension is relieved.
- c. Remove safety wire, relieve cable tension, disconnect turnbuckles (4) and carefully lower LEFT flap.
- d. Disconnect cables at drive pulleys, remove

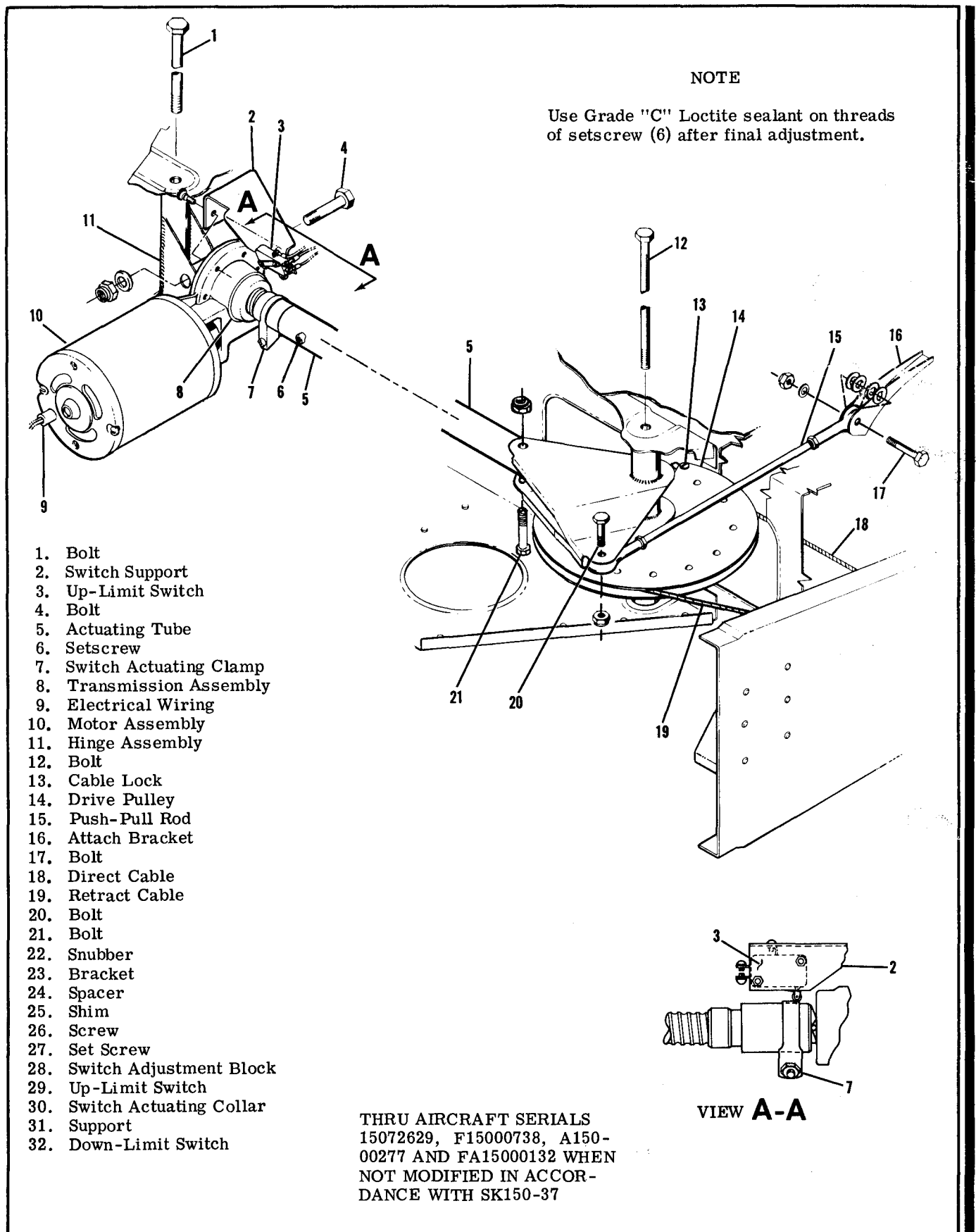
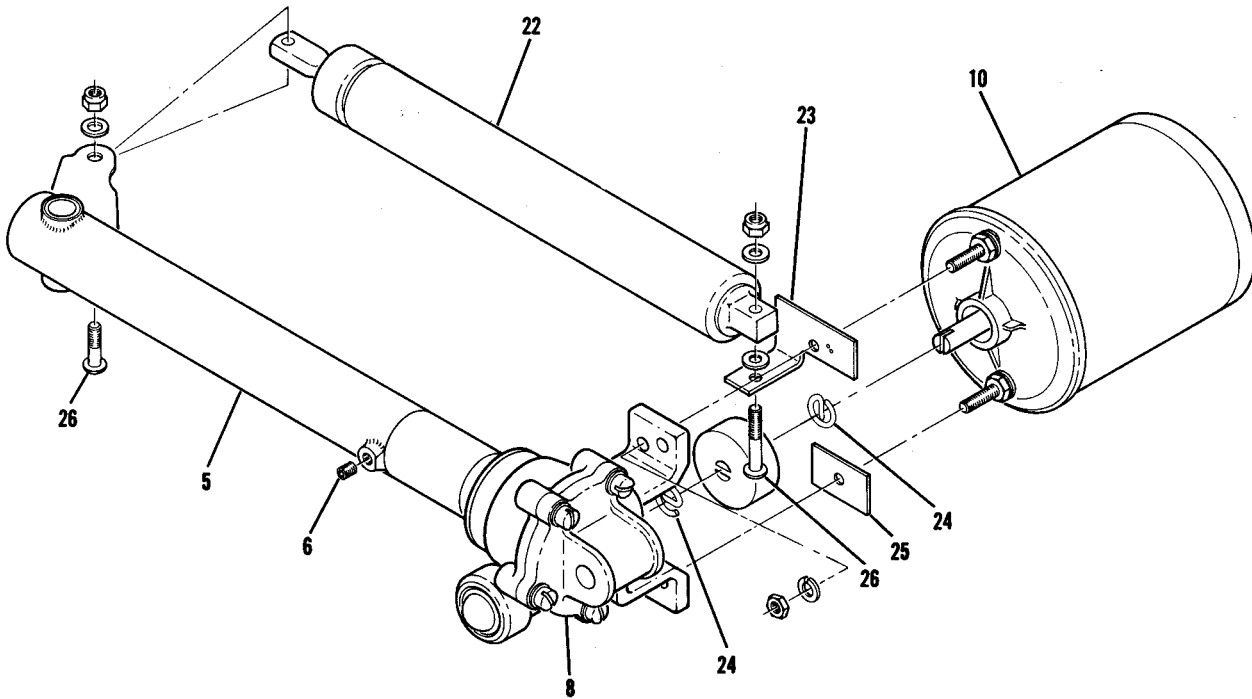
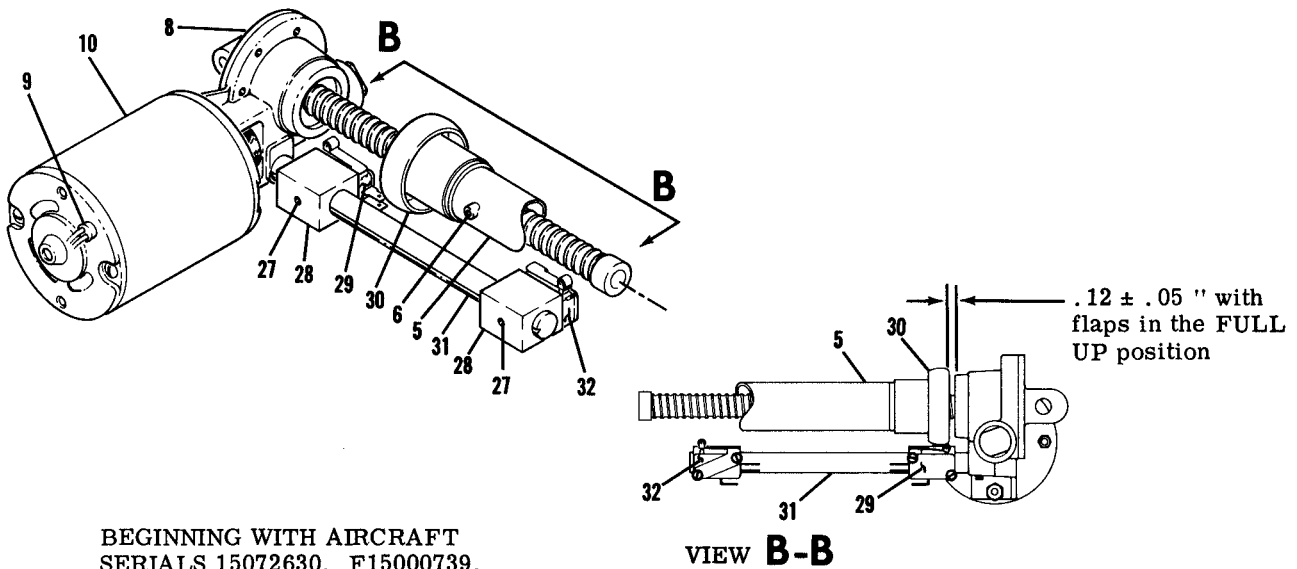

Figure 7-2. Flap Motor and Transmission Installation (Sheet 1 of 3)



AIRCRAFT SERIALS 15061533 THRU 15072629, F15000001 THRU F15000738, A15000001 THRU A15000277 AND FA15000001 THRU FA15000132 WHEN MODIFIED IN ACCORDANCE WITH SK150-37



BEGINNING WITH AIRCRAFT SERIALS 15072630, F15000739, A15000278 AND FA15000133

VIEW B-B

.12 ± .05 " with flaps in the FULL UP position

Figure 7-2. Flap Motor and Transmission Installation (Sheet 2 of 3)

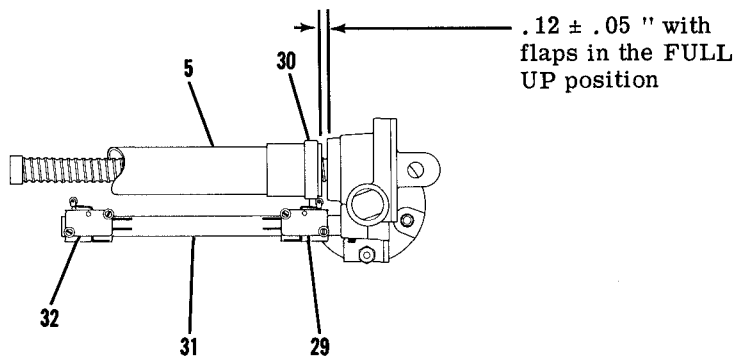
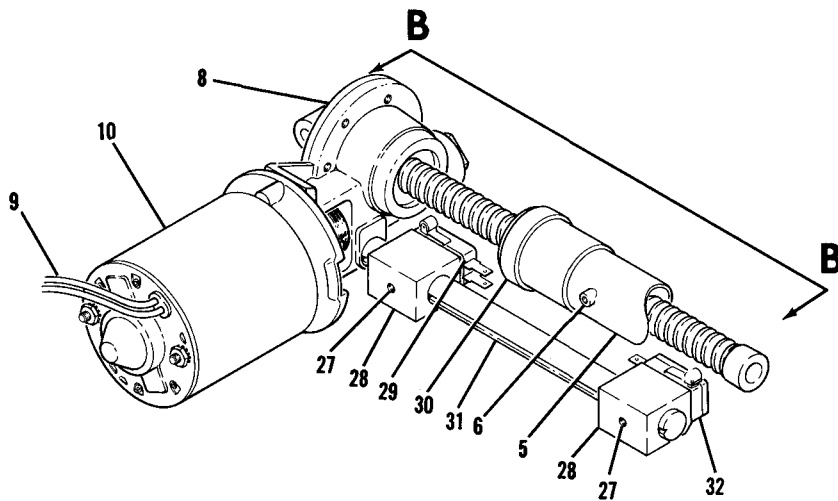

VIEW **B-B**

SK150-41 AND THIS FLAP ACTUATOR INSTALLATION IS EFFECTIVE ONLY WHEN USED AS A REPLACEMENT SPARE, OR ON PRODUCTION FLAP ACTUATOR INSTALLATIONS PRIOR TO AIRCRAFT SERIALS 15072630, F150-00739, A15000278 AND FA15000133

Figure 7-2. Flap Motor and Transmission Installation (Sheet 3 of 3)

NOTE

Bushings (4), rollers (3) and spacers (9) are first positioned through slots in flap tracks, then are secured to the flap roller supports (2) with attaching bolts, washers and nuts. Nylon plug buttons (11) prevent wing flap from chafing wing trailing edge.

Position spacers (9) and direction of bolts (5) as required to provide adequate flap clearance at wing root, flap well skin and aileron. Some lateral movement of flap is inherent due to the width of rollers. This movement should be considered when positioning spacers and direction of bolts.

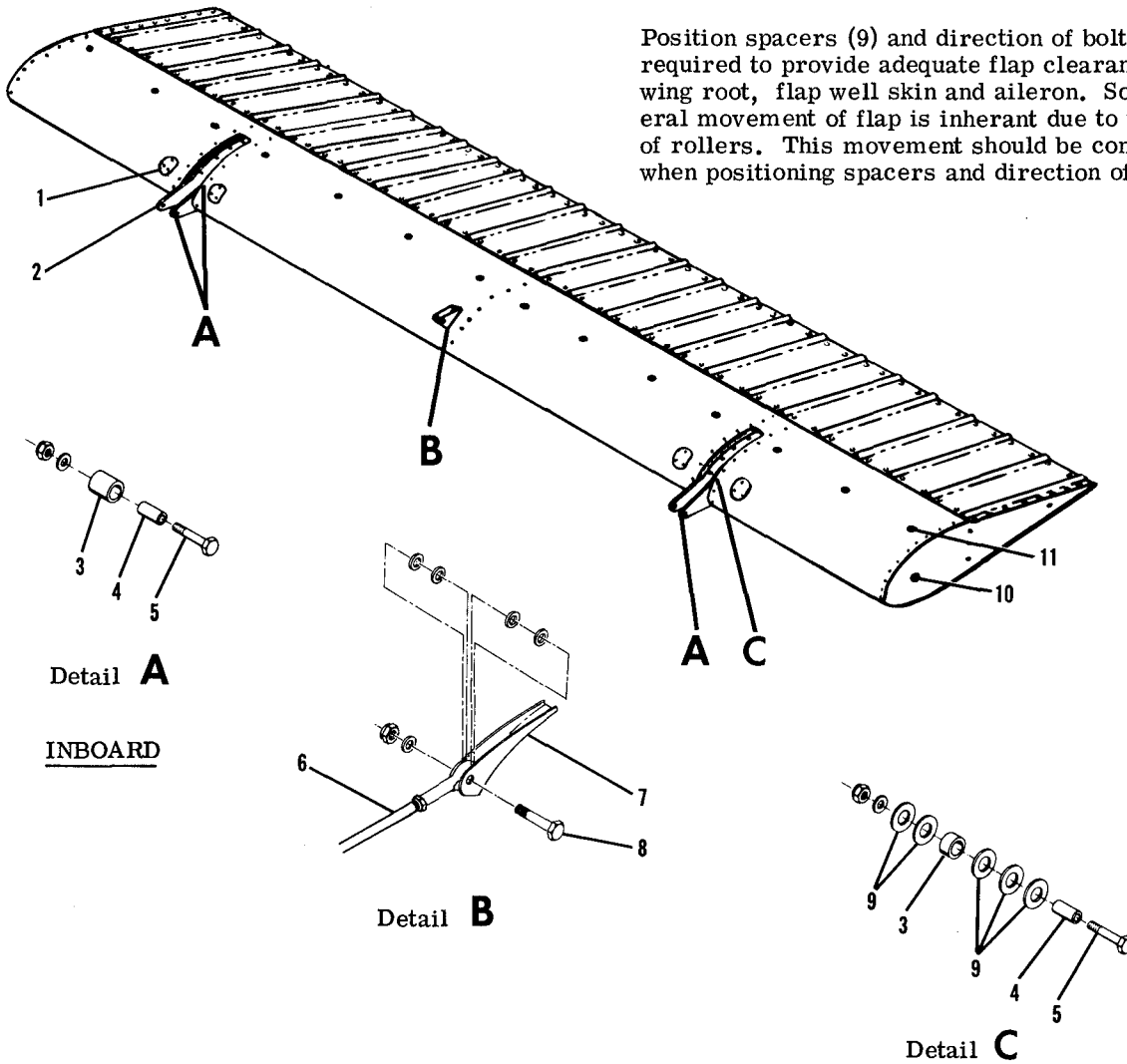

Detail A

INBOARD

Detail B

Detail C

OUTBOARD

1. Access Plate
2. Flap Support
3. Roller Assembly
4. Bushing
5. Bolt
6. Push-Pull Rod
7. Flap Bracket
8. Bolt
9. Spacer
10. Plug Button
11. Nylon Plug Button

Figure 7-3. Flap Installation

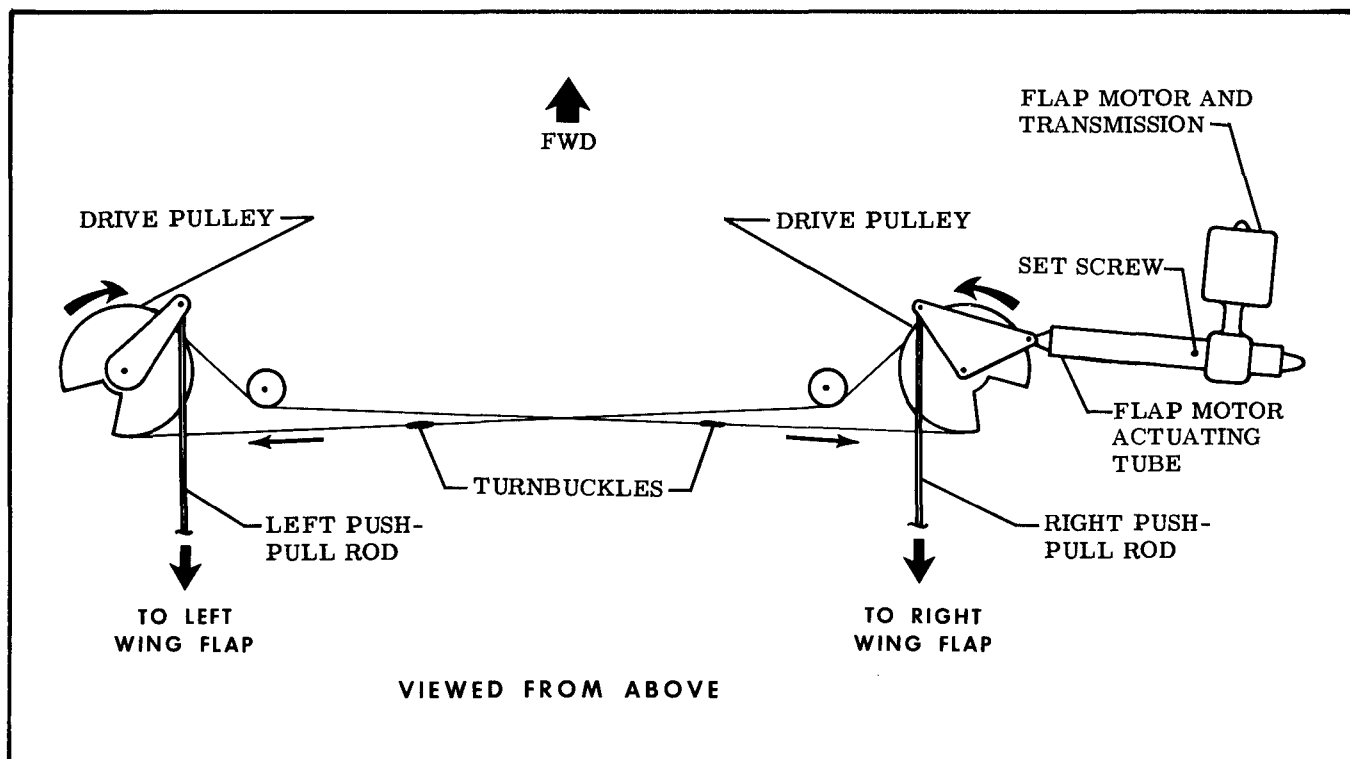

Figure 7-4. Flap System Schematic

cable guards and pulleys as necessary to work cables free of aircraft.

NOTE

To ease routing of cables, a length of wire may be attached to the end of cable being withdrawn from the aircraft. Leave wire in place, routed through structure; then attach the cable being installed and use wire to pull cable into position.

- e. Reverse the preceding steps for reinstallation.
- f. After cables are routed in position, install pulleys and cable guards. Ensure cables are positioned in pulley grooves before installing guards.
- g. Re-rig flap system in accordance with paragraph 7-16 and safety turnbuckles.
- h. Re-rig indicating system in accordance with paragraph 7-19 and reinstall all items removed in step "a."

7-16. RIGGING.

- a. (Refer to figure 7-1.) Unzip or remove headliner as necessary for access to turnbuckles (4).
- b. Disconnect indicator wire clamp (10) and slowly release indicator wire (11) until spring (16) tension is relieved.
- c. Remove safety wire, relieve cable tension, disconnect turnbuckles (4) and carefully lower LEFT flap.

- d. (Refer to figure 7-2.) Disconnect push-pull rods (15) at drive pulleys (14) in both wings and lower RIGHT flap gently.

- e. Disconnect actuating tube (5) from drive pulley (14).

NOTE

If control cables are not connected to left and right drive pulleys, actuating tube (5) and push-pull rods (15) must be disconnected before installing cables. If drive pulleys (14) are not installed, attach control cables before installing drive pulleys in the wings as illustrated in figure 7-4.

- f. Adjust both push-pull rods (15) to $8.83 \pm .12$ inches between centers of rod end bearings and tighten locknuts on both ends. Connect push-pull rods to flaps and drive pulleys.

NOTE

Temporarily connect cables at turnbuckles (index 4, figure 7-1) and test flaps by hand to ensure both flaps extend and retract together. If they will not, the cables are incorrectly attached to the drive pulleys. Ensure that the right drive pulley rotates clockwise when viewed from below, as the flaps are extended. Tag cables for reference and disconnect turnbuckles again.

g. THRU AIRCRAFT SERIALS 15072629, F15000738, A15000277 AND FA15000132 WHEN NOT MODIFIED IN ACCORDANCE WITH SK150-37 AND WHEN NOT MODIFIED IN ACCORDANCE WITH FIGURE 7-2, SHEET 3. (Refer to figure 7-2, sheet 1.) Screw actuating tube (5) IN toward transmission (8) by hand to its shortest length (flaps full up position). Loosen setscrew (6) securing actuating tube (5) to nut and ball assembly, hold nut and ball assembly so that it will not move, hold RIGHT flap in the full UP position and adjust actuating tube (5) IN or OUT as necessary to align with attachment hole in drive pulley (14). Tighten setscrew (6) and secure tube to drive pulley with bolt (21).

h. THRU AIRCRAFT SERIALS 15072629, F15000738, A15000277 AND FA15000132 WHEN MODIFIED IN ACCORDANCE WITH SK150-37 AND WHEN NOT MODIFIED IN ACCORDANCE WITH FIGURE 7-2, SHEET 3. (Refer to figure 7-2, sheet 2.) Operate flap motor until actuating tube (5) is IN to its shortest length (flaps full up position). Hold RIGHT flap in the full UP position and check actuating tube (5) to drive pulley (14) attachment holes for alignment. Operate flap motor toward the DOWN position until bolt (21) can be installed freely. Loosen setscrew (6) and rotate nut and ball assembly IN against transmission (8). Tighten setscrew (6) and bolt (21).

i. BEGINNING WITH AIRCRAFT SERIALS 15072630, F15000739, A15000278, FA15000133 AND ALL AIRCRAFT MODIFIED IN ACCORDANCE WITH FIGURE 7-2, SHEET 3. (Refer to figure 7-2, sheets 2 and 3.) Screw actuating tube (5) IN toward transmission (8) by hand to .12±.05 inches between switch actuating collar (30) and transmission as illustrated in figure 7-2, VIEW B-B. Loosen setscrew (6) securing actuating tube (5) to switch actuating collar (30), hold actuating collar to maintain .12±.05", hold RIGHT flap in the full UP position and adjust actuating tube (5) IN or OUT as necessary to align with attachment hole in drive pulley (14). Tighten setscrew (6) in accordance with procedures outlined in the following note and secure tube to drive pulley with bolt (21).

NOTE

Thru Aircraft Serials 15075326, F15001073, A1500464 and FA1500236: Tighten setscrew (6). Aircraft Serials 1507532 thru 15075740, F15001074 thru F15001143, A1500465 thru A1500499, FA1500237 thru FA1500261: Apply grade CV sealant to setscrew (6) threads and torque to 45 lb-in. Beginning with Aircraft Serials 15075741, F15001144, A1500500, FA1500262: Apply grade CV sealant to setscrew (6) threads and torque to 60 lb-in.

If actuating tube (5) is too long to allow attachment to drive pulley after completion of steps "g", "h" and "i", proceed to step "j".

j. Disconnect push-pull rod (15) at drive pulley (14), then connect actuating tube (5) to drive pulley.

k. Manually hold RIGHT flap in full UP position and readjust push-pull rod (15) to align with attachment hole in drive pulley. Connect push-pull rod and tighten locknuts or castellated nuts and install

cotter pins.

NOTE

The right flap and actuator must be correctly rigged before cables and left flap can be rigged.

l. THRU AIRCRAFT SERIALS 15072629, F15000738, A15000277 AND FA15000132 WHEN NOT MODIFIED IN ACCORDANCE WITH FIGURE 7-2, SHEET 3. After completion of step "k", with flap in full UP position, adjust up-limit switch clamp (7) to operate switch (3) and shut-off electrical power to motor at this position.

m. BEGINNING WITH AIRCRAFT SERIALS 15072630, F15000739, A15000278 AND FA15000133 AND ALL AIRCRAFT MODIFIED IN ACCORDANCE WITH FIGURE 7-2, SHEET 3. After completion of step "k", with flaps in full UP position, loosen setscrew (27) and slide up-limit switch adjustment block (28) on support (31) to operate switch and shut-off electrical power to motor at this position. Tighten setscrew (27).

n. Manually hold LEFT flap full UP and connect control cables at turnbuckles (index 4, figure 7-1). Remove reference tags previously installed in step "f" as turnbuckles are connected.

o. With flaps full UP, adjust turnbuckles to obtain 30±10 pounds tension on cables. Adjust retract cable (19) first.

NOTE

Ensure cables are positioned in pulley grooves and cable ends are positioned correctly at drive pulleys before tightening turnbuckles.

p. Disconnect push-pull rod at left drive pulley. Run motor to extend flaps approximately 20° and check tension on each flap cable. If necessary, re-adjust turnbuckles to maintain 30±10 pounds tension on each cable and safety turnbuckles.

q. Fully retract right flap. Manually hold left flap in full up position and readjust push-pull rod to align with attaching hole in drive pulley. Connect push-pull rod and tighten locknuts or castellated nuts and install cotter pins.

NOTE

An inclinometer for measuring control surface travel is available from the Cessna Service Parts Center. Refer to figure 6-4.

r. Mount an inclinometer on one flap and adjust to 0°. Extend flaps and check down angle as follows:

s. THRU AIRCRAFT SERIALS 15072629, F15000738, A15000277 AND FA15000132 WHEN NOT MODIFIED IN ACCORDANCE WITH FIGURE 7-2, SHEET 3.

After completion of steps "a" thru "r", the flap down angle should be as specified in figure 1-1. Repeat down angle check on opposite flap.

t. BEGINNING WITH AIRCRAFT SERIALS 15072630, F15000739, A15000278, FA15000133 AND ALL AIRCRAFT MODIFIED IN ACCORDANCE WITH FIGURE 7-2, SHEET 3. After completion of steps "a" thru

"r", adjust down-limit switch (32) to operate and shut-off electrical power to motor at degree of travel specified in figure 1-1. Repeat down angle check on opposite flap. Check operation of limit switches for positive shut-off through several cycles.

NOTE

Since the flap rollers may not bottom in the flap tracks with flaps fully extended, some free play may be noticed in this position.

u. Connect and re-rig indicating system in accordance with paragraph 7-19, perform an operational check in accordance with paragraph 7-3, check all locknuts for tightness, all turnbuckles are saftied and reinstall all items removed for access.

7-17. INDICATING SYSTEM. (Refer to figure 7-1.)

7-18. DESCRIPTION. The mechanical indicating system consists of a tubing-enclosed flexible wire attached to the flap direct cable at one end and to

a pointer at the other end. Movement of the flap direct cable pulls the pointer along a scale to indicate flap position as the flaps are extended. Opposite movement of the flap direct cable permits a return spring, attached to the pointer, to pull pointer in the opposite direction as the flaps are raised.

7-19. RIGGING.

- a. Operate flaps to full UP position.
- b. Open zipper or remove headliner as necessary for access.
- c. Loosen clamp (10) securing flexible wire (11) to flap direct cable (2) and adjust wire as required to place pointer at 0° (flaps up) position on indicator. Wrap wire (11) around clamp bolt a minimum of 2 times and tighten bolt.
- d. Cycle flaps to check proper operation of indicating system.
- e. Close zipper or replace headliner removed in step "b."

This page intentionally left blank.

SECTION 8

ELEVATOR CONTROL SYSTEM

TABLE OF CONTENTS		Page		
ELEVATOR CONTROL SYSTEM	8-1		Forward	8-2
Description	8-1		Removal and Installation	8-2
Trouble Shooting	8-1		Rear	8-2
Elevators	8-2		Removal and Installation	8-2
Removal and Installation	8-2		Cables and Pulleys	8-2
Repair	8-2		Removal and Installation	8-2
Bellcranks	8-2		Rigging	8-6

8-1. ELEVATOR CONTROL SYSTEM.

The rear bellcrank serves as an interconnect between the elevators and a bearing point for the travel stop bolts. An elevator trim tab is installed on the right elevator and is described in Section 9.

8-2. DESCRIPTION. The elevators are operated by power transmitted from the control wheels through a series of cables, bellcranks and a push-pull tube.

8-3. TROUBLE SHOOTING.

NOTE

Due to remedy procedures in the following trouble shooting chart it may be necessary to re-rig system, refer to paragraph 8-14.

TROUBLE	PROBABLE CAUSE	REMEDY
NO RESPONSE TO CONTROL WHEEL FORE-AND-AFT MOVEMENT.	Forward or aft end of push-pull tube disconnected.	Attach push-pull tube correctly.
	Cables disconnected.	Attach cables and rig system in accordance with paragraph 8-14.
BINDING OR JUMPY MOTION FELT IN MOVEMENT OF ELEVATOR SYSTEM.	Defective forward or rear bellcrank pivot bearing.	Replace bellcrank.
	Cables slack.	Adjust to tension specified in figure 8-1.
	Cables not riding correctly on pulleys.	Route cables correctly over pulleys.
	Nylon grommet on instrument panel binding.	Replace grommet.
	Defective control "y" pivot bearing.	Replace bearing.
	Defective elevator hinges or lubrication needed.	Replace defective hinges. Lubricate per Section 2.
	Clevis bolts too tight.	Readjust to eliminate bolt binding.
	Lubrication needed.	Lubricate piano hinges.
Defective pulleys or cable guards.	Replace defective parts and install guards properly.	

8-3. TROUBLE SHOOTING (Cont).

TROUBLE	PROBABLE CAUSE	REMEDY
ELEVATORS FAIL TO ATTAIN PRESCRIBED TRAVEL.	Stops incorrectly set.	Rig system in accordance with paragraph 8-14.
	Cables tightened unevenly.	Rig system in accordance with paragraph 8-14.
	Interference at firewall or instrument panel.	Rig system in accordance with paragraph 8-14.

8-4. ELEVATORS. (Refer to figure 8-2.)

8-5. REMOVAL AND INSTALLATION.

NOTE

This procedure is written primarily for the right elevator since the trim tab is attached to this elevator.

- a. Disconnect trim tab push-pull tube (2) at tab actuator.
- b. Remove bolts (8) securing elevators to bellcrank (7).

NOTE

If trim system is not moved and actuator screw is not turned, rigging of trim system should not be necessary after installation of elevator.

- c. Remove bolts (10) from elevator hinges.
- d. Using care, remove elevator.
- e. To remove left elevator use same procedure, omitting step "a".
- f. Reverse preceding steps for installation. Rig system in accordance with applicable paragraph in this section if necessary.

8-6. REPAIR. Repair may be accomplished as outlined in Section 18. Hinge bushings may be replaced as necessary. If repair has affected static balance, check and rebalance as required.

8-7. BELLCRANKS.

8-8. FORWARD. (Refer to figure 8-1.)

8-9. REMOVAL AND INSTALLATION.

- a. Remove seats, upholstery and access plates as necessary.
- b. Relieve cable tension at turnbuckles (10) and disconnect cables from bellcrank (14).
- c. Disconnect push-pull tube (15) from bellcrank.
- d. Remove pivot bolt (13) and remove bellcrank.
- e. Reverse preceding steps for installation. Rig system in accordance with applicable paragraph in

this section, safety turnbuckles and reinstall all items removed in step "a".

8-10. REAR. (Refer to figure 8-2.)

8-11. REMOVAL AND INSTALLATION.

- a. Remove rudder. (Refer to Section 10.)
- b. Remove seats, upholstery and access plates as necessary for access to turnbuckles (index 10, figure 8-1).
- c. Relieve cable tension at turnbuckles and disconnect cables from rear bellcrank (7).
- d. Remove bolts (8) securing elevators to bellcrank.
- e. Remove bellcrank pivot bolt and slide bellcrank from between tube assemblies (6).

NOTE

It may be necessary to remove one of the attaching bolts (10) for clearance when removing the bellcrank pivot bolt.

- f. Reverse preceding steps for installation. Rig system in accordance with applicable paragraph in this section, safety turnbuckles and reinstall all items removed in step "b".

8-12. CABLES AND PULLEYS. (Refer to figure 8-1.)

8-13. REMOVAL AND INSTALLATION.

- a. Remove seats, upholstery and access plates as necessary.
- b. Relieve cable tension at turnbuckles (10).
- c. Disconnect cables at forward bellcrank links (12).
- d. Disconnect cables at rear bellcrank (9).
- e. Remove fairleads, cable guards and pulleys as necessary to work cables free of aircraft.

NOTE

To ease routing of cables, a length of wire may be attached to end of cable before being withdrawn from aircraft. Leave wire in place, routed through structure, attach cable being installed and pull cable into position.

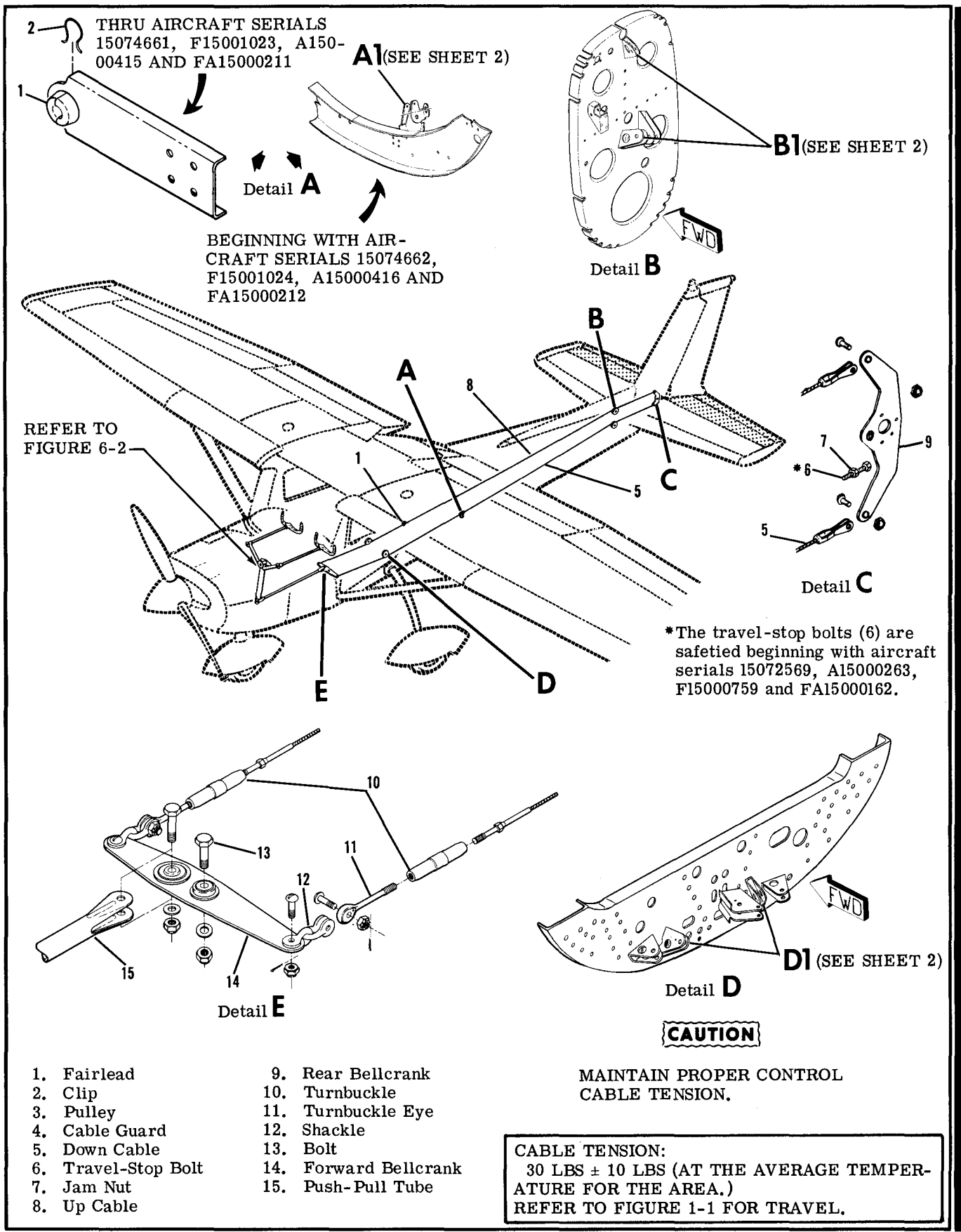
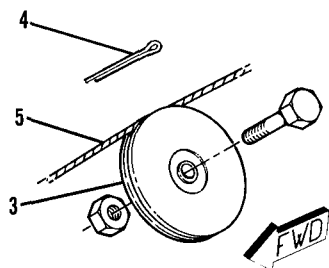
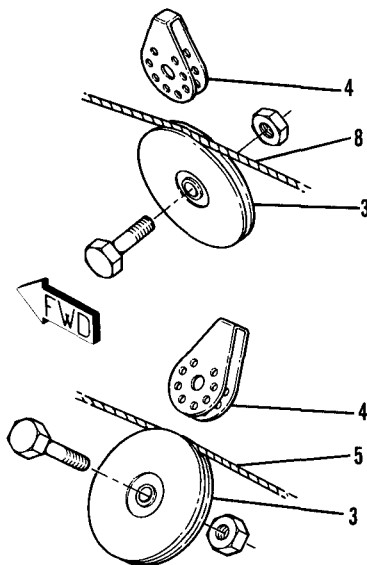

Figure 8-1. Elevator Control System (Sheet 1 of 2)



BEGINNING WITH AIRCRAFT
SERIALS 15074662, F15001024,
A15000416 AND FA15000212

Detail **A1**



Detail **B1**

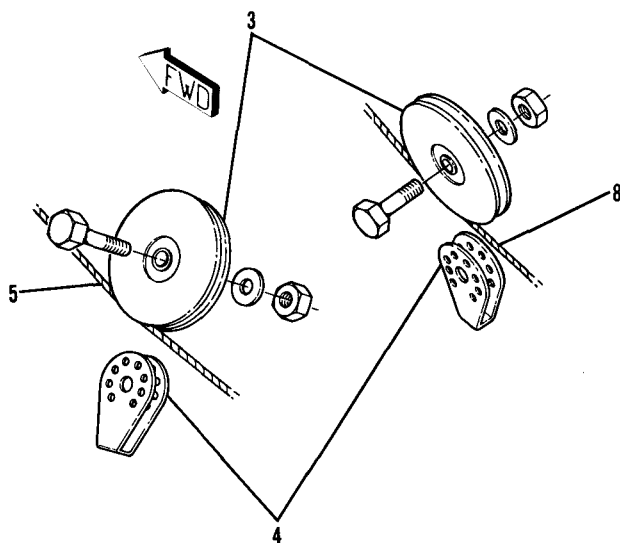

Detail **D1**

Figure 8-1. Elevator Control System (Sheet 2 of 2)

- Castellated nuts and pins replace existing nuts on push-pull tube (2) attach bolts beginning with aircraft serials 15071905, A15000198, F15000620 and FA15000062.

- Thru aircraft serials 15072435, F15000778, A15000256 and FA15000161

- * Beginning with aircraft serials 15072436, F15000779, A15000257 and FA15000162

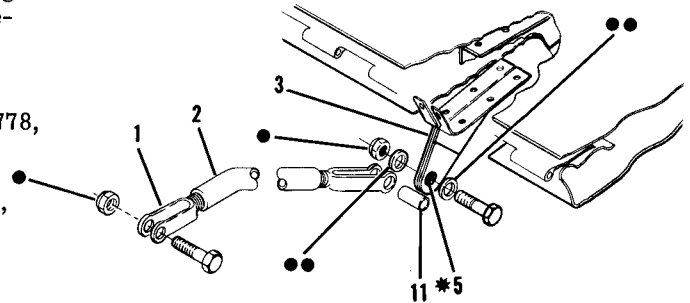

Detail B

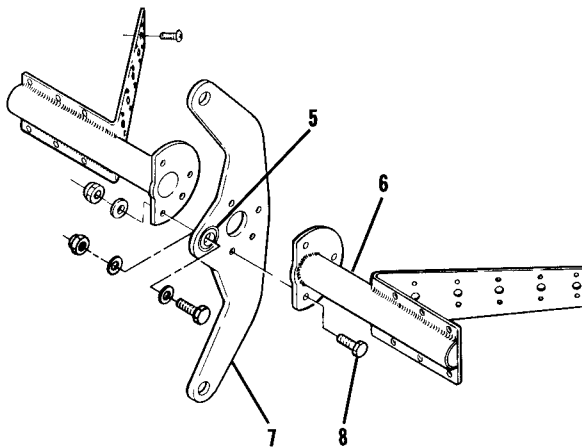
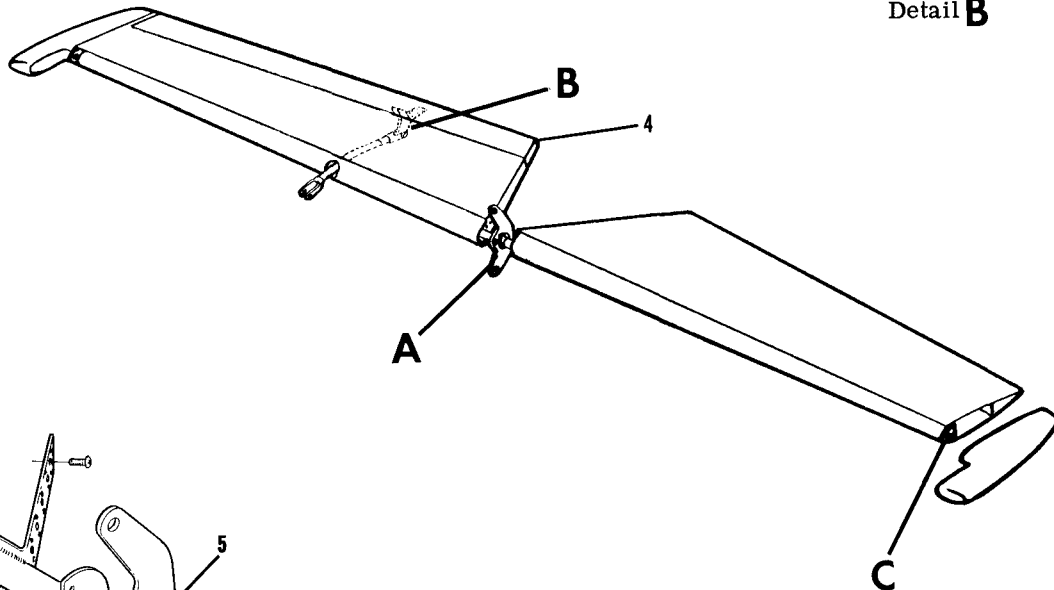

Detail A

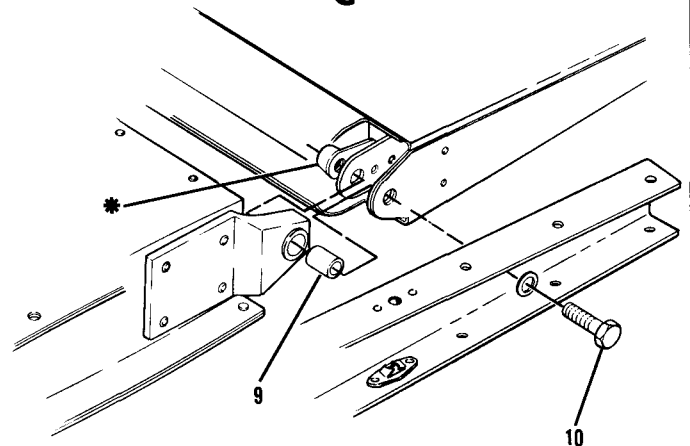

Detail C

1. Clevis
2. Push-Pull Tube
3. Horn Assembly
4. Trim Tab
5. Bearing
6. Tube Assembly
7. Bellcrank
8. Bolt
9. Spacer
10. Bolt
11. Bushing

* Castellated nuts and pins beginning with aircraft serials 15071622, F15000700, A15000130 and FA15000040

Figure 8-2. Elevator Installation

f. After cable is routed in position, install pulleys and cable guards. Ensure cable is positioned in pulley groove before installing guards.

g. Rig system in accordance with applicable paragraph in this section, safety turnbuckles and re-install all items removed in step "a".

b. Place an inclinometer on one elevator and set to zero.

c. Adjust elevator stops (6) to attain travel specified in Section 1.

d. Remove seats, upholstery and access plates as necessary for access to turnbuckles (10).

e. Adjust cables to 30 ± 10 pounds tension by tightening turnbuckles (10). Ensure control "Y" does not contact instrument panel in full-up position or firewall in full-down position.

f. Safety turnbuckles and reinstall all items removed in step "d".

8-14. RIGGING. (Refer to figure 8-1.)

NOTE

An inclinometer for measuring control surface travel is available from Cessna Service Parts Center. Refer to figure 6-4.

a. Locate neutral position of elevators by streamlining elevators with stabilizer.

WARNING

Be sure elevators move in correct direction when operated by control wheel.

SHOP NOTES:

SECTION 9
ELEVATOR TRIM CONTROL SYSTEM

TABLE OF CONTENTS	Page		
ELEVATOR TRIM CONTROL SYSTEM	9-1	Trim Tab Free-Play Inspection	9-4A
Description	9-1	Trim Tab Control Wheel	9-6
Trouble Shooting	9-1	Removal and Installation	9-6
Trim Tab	9-2	Cables and Pulleys	9-6
Removal and Installation	9-2	Removal and Installation	9-6
Trim Tab Actuator	9-2	Rigging	9-6
Removal and Installation	9-2		
Disassembly	9-2		
Cleaning, Inspection and Repair	9-4A		
Reassembly	9-4A		

9-1. ELEVATOR TRIM CONTROL SYSTEM. (Refer to figure 9-1.)

9-2. DESCRIPTION. The elevator trim tab, located on the right elevator, is controlled by a trim wheel mounted in the lower instrument panel. Power

to operate the tab is transmitted from the trim control wheel by means of chains, cables and an actuator. A mechanical pointer, adjacent to the trim wheel indicates tab position. A "nose-up" setting results in a tab-down position.

9-3. TROUBLE SHOOTING.

NOTE

Due to remedy procedures in the following trouble shooting chart it may be necessary to re-rig system, refer to paragraph 9-12.

TROUBLE	PROBABLE CAUSE	REMEDY
TRIM CONTROL WHEEL MOVES WITH EXCESSIVE RESISTANCE.	Cable tension too high.	Adjust tension.
	Pulleys binding or rubbing.	Repair or replace as necessary.
	Cables not in place on pulleys.	Install cables correctly.
	Trim tab hinge binding.	Lubricate or replace hinge as necessary.
	Defective trim tab actuator.	Replace actuator.
	Rusty chain.	Replace rusty chain.
	Damaged sprocket.	Replace damaged sprockets.
Bent sprocket shaft.	Replace bent sprocket shafts.	

8-3. TROUBLE SHOOTING (Cont).

TROUBLE	PROBABLE CAUSE	REMEDY
LOST MOTION BETWEEN CONTROL WHEEL AND TRIM TAB.	Cable tension too low.	Adjust tension.
	Broken pulley.	Replace defective pulley.
	Cables not in place on pulleys.	Install cables correctly.
	Worn trim tab actuator.	Remove and replace worn actuator.
	Actuator attachment loose.	Tighten.
TRIM INDICATOR FAILS TO INDICATE CORRECT TRIM POSITION.	Indicator incorrectly engaged on wheel track.	Reset indicator.
INCORRECT TRIM TAB TRAVEL.	Stop blocks loose or incorrectly adjusted.	Adjust stop blocks on cables.

9-4. TRIM TAB. (Refer to figure 8-2.)

9-5. REMOVAL AND INSTALLATION.

- a. Disconnect push-pull tube (2) from horn assembly (3).
- b. Drill out rivets attaching hinge to elevator.

NOTE

After tab has been removed and if hinge pin is to be removed, it is necessary to spread the crimped ends of the hinge before driving out pin. When a pin has been installed, crimp ends of hinge to prevent pin from working out.

- c. Reverse preceding steps for installation.

9-6. TRIM TAB ACTUATOR.

9-7. REMOVAL AND INSTALLATION. (Refer to figure 9-1.)

CAUTION

Position a support stand under tail tie-down ring to prevent tailcone from dropping while working inside.

- a. Remove baggage compartment aft wall for access.
- b. Remove safety wire and relieve cable tension at turnbuckle (15).

- c. Disconnect push-pull tube (12) from actuator (9).
- d. Remove access plate from underside of right hand stabilizer beneath actuator.
- e. Remove chain guard (8) and disengage chain (8A) from actuator sprocket.
- f. Remove screws (8B) and spacers (10) attaching actuator clamps to stabilizer structure (11) and carefully work actuator out through access opening.
- g. Reverse the preceding steps for reinstallation. Rig trim system in accordance with paragraph 9-12, safety turnbuckle (15) and reinstall all items removed for access.

9-7A. DISASSEMBLY. (Refer to figure 9-2.)

- a. Remove actuator in accordance with paragraph 9-7.
- b. Disassemble actuator assembly (1) as illustrated in Detail A as follows:
 1. Remove chain guard (3) if not previously removed in step "e" of paragraph 9-7.
 2. Using suitable punch and hammer, remove groov-pins (8) securing sprocket (5) to screw (9) and remove sprocket from screw.
 3. Unscrew threaded rod end (15) and remove rod end from actuator.
 4. Remove groov-pins (10) securing bearings (6 and 14) at the housing ends.
 5. Lightly tap screw (9) toward the sprocket end of housing, remove bearing (6) and collar (7).
 6. Lightly tap screw (9) in the opposite direction from sprocket end, remove bearing (14), O-ring (13) and collar (7).

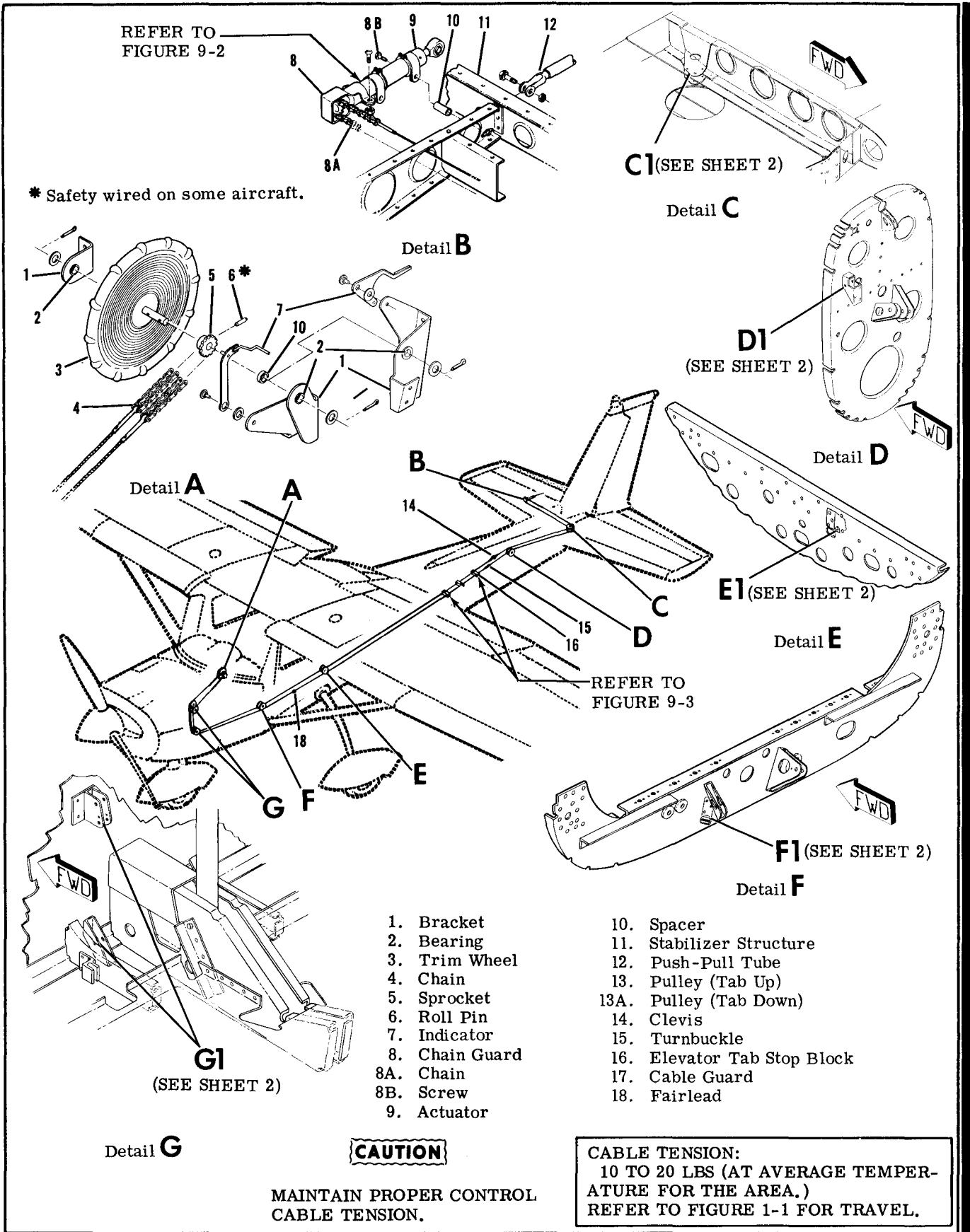
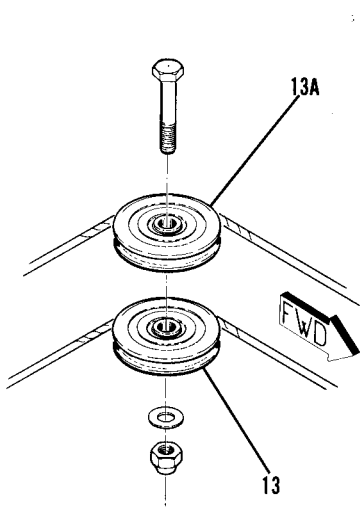
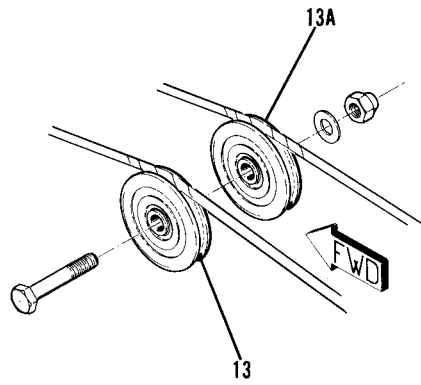

Figure 9-1. Elevator Trim Control System (Sheet 1 of 2)



Detail **C1**



Detail **D1**

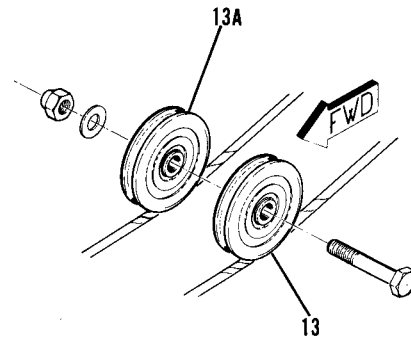

Detail **E1**

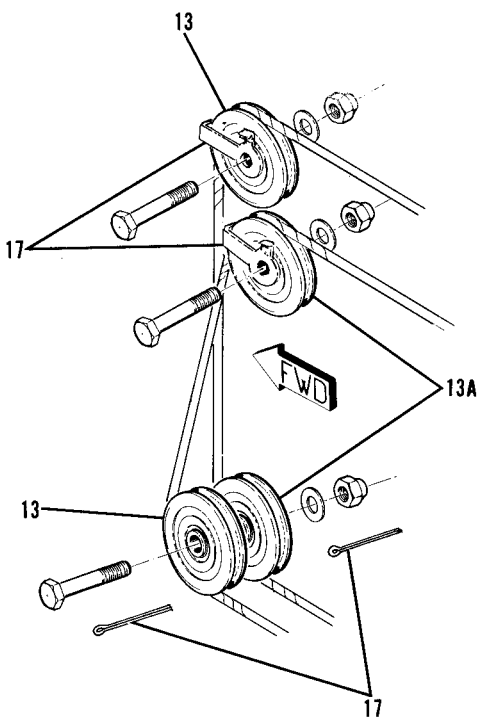

Detail **G1**

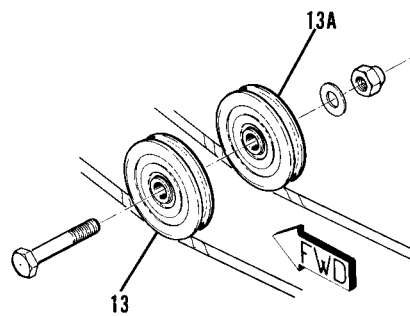

Detail **F1**

Figure 9-1. Elevator Trim Control System (Sheet 2 of 2)

7. It is not necessary to remove retaining rings (11).

9-7B. CLEANING, INSPECTION AND REPAIR.

(Refer to figure 9-2.)

- a. DO NOT remove bearing (16) from threaded rod end (15) unless replacement of bearing is necessary.
- b. Clean all component parts, except bearing (16), by washing in Stoddard solvent or equivalent. Do not clean sealed bearing (16).
- c. Inspect all component parts for obvious indications of damage such as stripped threads, cracks, deep nicks and dents.
- d. Check bearings (6 and 14), screw (9) and threaded rod end (15) for excessive wear and scoring. Dimensions of the parts are as follows:

BEARING (6)	
INSIDE DIAMETER	0.373" MIN.
INSIDE DIAMETER	0.380" MAX.
BEARING (14)	
INSIDE DIAMETER	
SMALL HOLE	0.248" MIN.
SMALL HOLE	0.253" MAX.
LARGE HOLE	0.373" MIN.
LARGE HOLE	0.380" MAX.
THREADED ROD END	
OUTSIDE DIAMETER	
(SHANK)	0.242" MIN.
	0.246" MAX.
SCREW (9)	
OUTSIDE DIAMETER	0.367" MIN.
	0.370" MAX.

NOTE

Relative linear movement between internal threaded screw (9) and bearing (14) should be 0.004 to 0.010 inch at room temperature.

- e. Examine threaded rod end (15) and screw (9) for damaged threads or dirt particles that may impair smooth operation.
- f. Check sprocket (5) for broken, chipped and/or worn teeth.
- g. Check bearing (16) for smoothness of operation.
- h. DO NOT attempt to repair damaged or worn parts of the actuator assembly. Discard all defective items and install new parts during reassembly.

9-7C. REASSEMBLY. (Refer to figure 9-2.)

- a. Always discard the following items and install new parts during reassembly:
 1. Bearings (6 and 14).
 2. Groov-Pins (8 and 10).
 3. O-Ring (13).
 4. Nuts (2).
- b. During reassembly, lubricate collars (7), screw (9) and threaded rod end (15) in accordance with Section 2.
- c. Press sprocket (5) into the end of screw (9), align groov-pin holes and install new groov-pins (8).
- d. Slip bearing (6) and collar (7) on screw (9) and slide them down against sprocket (5).

e. Insert screw (9), with assembled parts, into housing (12) until bearing (6) is flush with the end of housing.

NOTE

When inserting screw (9) into housing (12), locate the sprocket (5) at the end of housing which is farther away from the groove for retaining ring (11).

- The bearings (6 and 14) are not pre-drilled and must be drilled on assembly. The groov-pins (10) are 1/16 inch in diameter, therefore, requiring a 1/16 (0.0625) inch drill.

f. With bearing (6) flush with end of housing (12), carefully drill bearing so the drill will emerge from the hole on the opposite side of housing (12). DO NOT ENLARGE HOLES IN HOUSING.

- g. Press new groov-pins (10) into pin holes.
- h. Insert collar (7), new O-ring (13) and bearing (14) into opposite end of housing (12).
- i. Complete steps "f" and "g" for bearing (14).
- j. If a new bearing (16) is required, a new bearing may be pressed into the boss. Be sure force bears against the outer race of bearing.
- k. Screw the threaded rod end (15) into screw (9).
- l. Install retaining rings (11), if they were removed.
- m. Test actuator assembly by rotating sprocket (5) with fingers while holding threaded rod end (15). The threaded rod end should travel in and out smoothly with no indication of binding.
- n. Reinstall actuator assembly in accordance with paragraph 9-7.

9-7D. TRIM TAB FREE-PLAY INSPECTION.

- a. Place elevators and trim tab in the neutral position.
- b. Using moderate pressure, move the trim tab trailing edge up and down by hand to check free-play.
- c. A maximum of .112" (total motion up and down) measured at the trim tab trailing edge is permissible.
- d. If the trim tab free-play is less than .112", the system is within prescribed limits.
- e. If the trim tab free-play is more than .112", check the following items for looseness while moving the trim tab up and down.
 1. Check push-pull tube to trim tab horn assembly attachment for looseness.
 2. Check push-pull tube to actuator assembly threaded rod end attachment for looseness.
 3. Check actuator assembly threaded rod end for looseness in the actuator assembly.
- f. If looseness is apparent while checking steps e-1 and e-2, repair by installing new parts.
- g. If looseness is apparent while checking step e-3, refer to paragraphs 9-6 through 9-7C.

This page intentionally left blank.

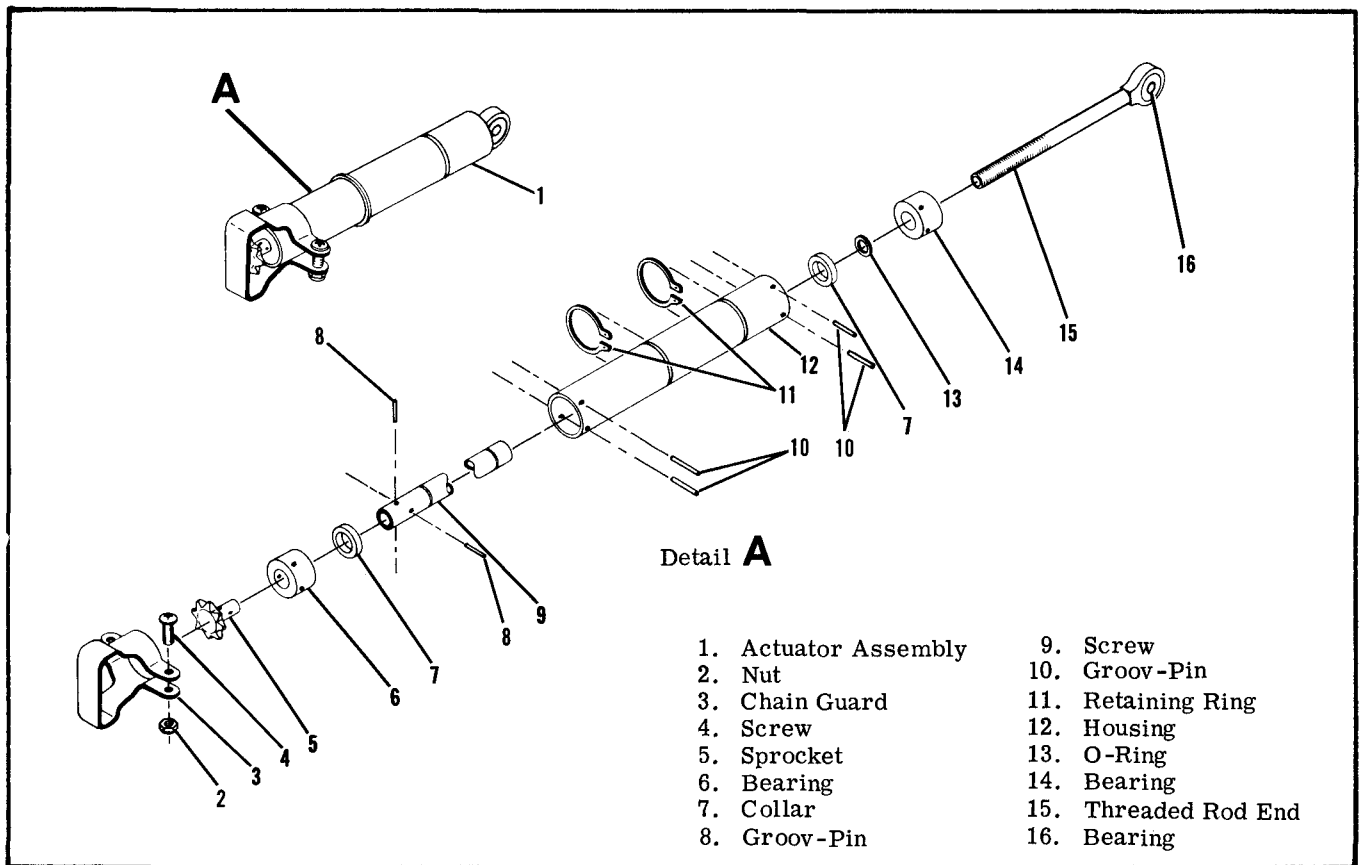

Figure 9-2. Elevator Trim Tab Actuator Assembly

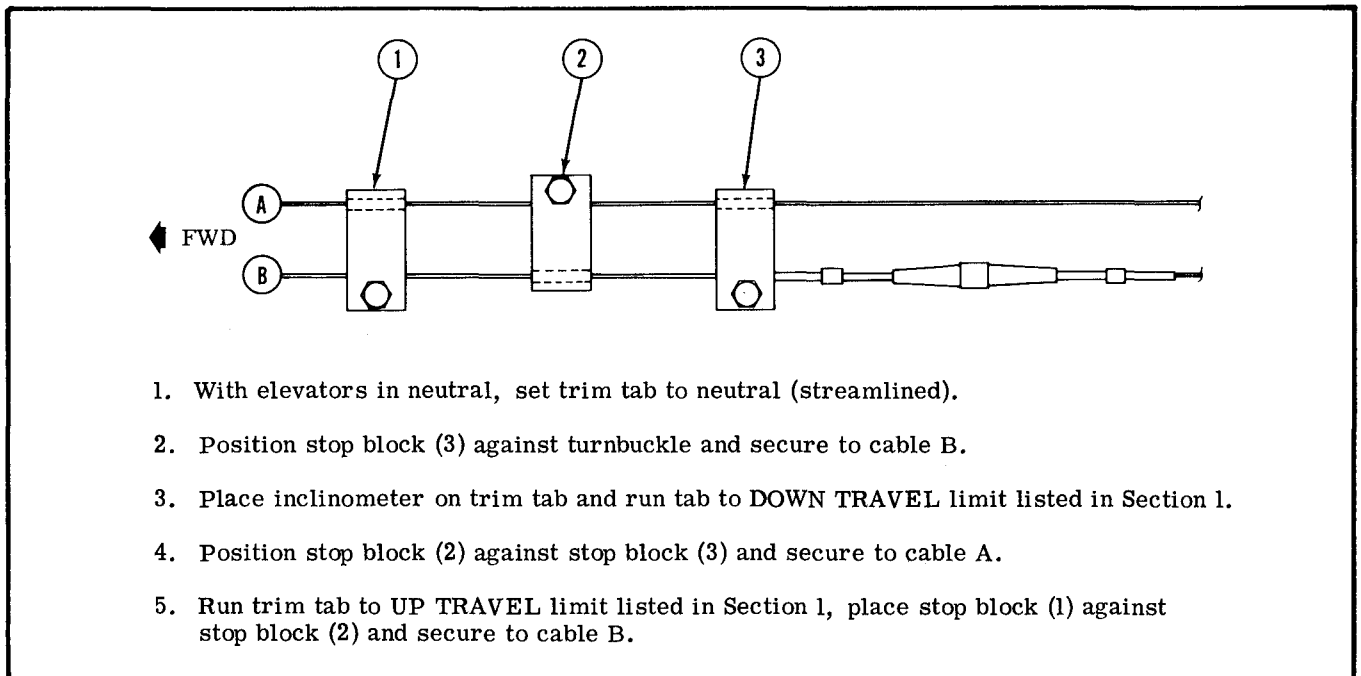

Figure 9-3. Elevator Trim Tab Travel Adjustment

9-8. TRIM TAB CONTROL WHEEL. (Refer to figure 9-1.)

9-9. REMOVAL AND INSTALLATION.

- a. Relieve cable tension at turnbuckle (15).

CAUTION

Position a support stand under tail tie-down ring to prevent tailcone from dropping while working inside.

- b. Disengage chain from sprocket (5).
- c. Remove cotter pin at each end of trim wheel shaft.
- d. Slide shaft assembly into either bearing (2) as far as possible.
- e. Carefully deform brackets (1) and slide shaft assembly free of bearings (2).
- f. Reverse preceding steps for installation. Rig system in accordance with applicable paragraph in this section, safety turnbuckle and reinstall all items removed for access.

9-10. CABLES AND PULLEYS. (Refer to figure 9-1.)

9-11. REMOVAL AND INSTALLATION.

- a. Remove seats, upholstery and access plates as necessary.
- b. Disconnect cables at turnbuckle (15) and clevis (14).
- c. Remove fairlead, cable guards and pulleys as necessary to work cables free of aircraft.

NOTE

To ease routing of cables, a length of wire may be attached to end of cable before being withdrawn from aircraft. Leave wire in place, routed through structure, attach cable being installed and pull cable into position.

- d. After cable is routed in position, install pulleys and cable guards. Ensure cable is positioned in pulley groove before installing guards.
- e. Rig system in accordance with applicable paragraph in this section, safety turnbuckle and reinstall all items removed in step "a."

9-12. RIGGING. (Refer to figure 9-1.)

CAUTION

Position a support stand under tail tie-down ring to prevent tailcone from dropping while working inside.

- a. Remove rear baggage compartment panel and access plates as necessary.
- b. Loosen travel stop blocks (16) on cables.

- c. Disconnect actuator (9) from push-pull tube (12).
- d. Check cable tension and readjust turnbuckle (15) if necessary.

NOTE

If chains and/or cables are being installed, permit actuator screw to rotate freely as chains and cables are connected. Set cable tension.

- e. Rotate trim wheel (3) full forward (nose down). Ensure that indicator (7) does not restrict wheel movement. If necessary, reposition indicator using a thin screwdriver to pry trailing leg of indicator out of groove.

NOTE

Full forward (nose down) position of trim wheel is where further movement is prevented by chain or cable ends contacting sprockets or pulleys.

- f. With elevator and trim tab both in neutral (streamlined), place inclinometer on tab and set to zero.

NOTE

An inclinometer for measuring control surface travel is available from Cessna Service Parts Center. Refer to figure 6-4.

- g. Rotate actuator screw in or out as required to place tab up with a maximum of 2° overtravel, with actuator screw connected to push-pull tube (12).
- h. Rotate trim wheel to position tab up and down, readjusting actuator screw as required to obtain overtravel in both directions.
- i. Position stop blocks (16) and adjust as illustrated in figure 9-3 to limit travel to the degree specified in Section 1.
- j. Check that trim wheel indicator travels same distance from ends of slot in cover. Reposition trailing leg of indicator if necessary (refer to step "e").
- k. Safety turnbuckle and reinstall all items removed in step "a".

WARNING

Be sure trim tab moves in correct direction when operated by trim wheel. Nose down trim corresponds to tab up position.

SECTION 10

RUDDER CONTROL SYSTEM

TABLE OF CONTENTS

Page

RUDDER CONTROL SYSTEM	10-1	Removal and Installation	10-4
Description	10-1	Repair	10-4
Trouble Shooting	10-1	Cables and Pulleys	10-5
Rudder Pedal Assembly	10-4	Removal and Installation	10-5
Removal and Installation	10-4	Rigging	10-5
Rudder	10-4		

10-1. RUDDER CONTROL SYSTEM. (Refer to figure 10-1.)

control nose wheel steering. The system is comprised of rudder pedals, cables and pulleys, all of which link the pedals to the rudder and nose wheel steering. Beginning with 1975 Models, rudder is vertically extended 6 inches and balance weight repositioned as depicted in figure 10-3.

10-2. DESCRIPTION. Rudder control is maintained through use of conventional rudder pedals which also

10-3. TROUBLE SHOOTING.

NOTE

Due to remedy procedures in the following trouble shooting chart it may be necessary to re-rig system, refer to paragraph 10-11.

TROUBLE	PROBABLE CAUSE	REMEDY
RUDDER DOES NOT RESPOND TO PEDAL MOVEMENT.	Broken or disconnected cables.	Connect or replace cables.
BINDING OR JUMPY MOVEMENT OF RUDDER PEDALS.	Cables too tight.	Adjust cable tension in accordance with paragraph 10-11.
	Cables not riding properly on pulleys.	Route cables correctly over pulleys.
	Binding, broken or defective pulleys or cable guards.	Replace defective pulleys and install guards properly.
	Pedal bars need lubrication.	Refer to Section 2.
	Defective rudder bar bearings.	Replace bearing blocks.
	Defective rudder hinge bushings or bellcrank bushings.	Replace defective bushings.
	Clevis bolts too tight.	Readjust to eliminate binding.
	Steering rods not adjusted properly.	Rig system in accordance with paragraph 10-11.
LOST MOTION BETWEEN RUDDER PEDALS AND RUDDER.	Insufficient cable tension.	Adjust cable tension in accordance with paragraph 10-11.
INCORRECT RUDDER TRAVEL.	Incorrect rigging.	Rig system in accordance with paragraph 10-11.

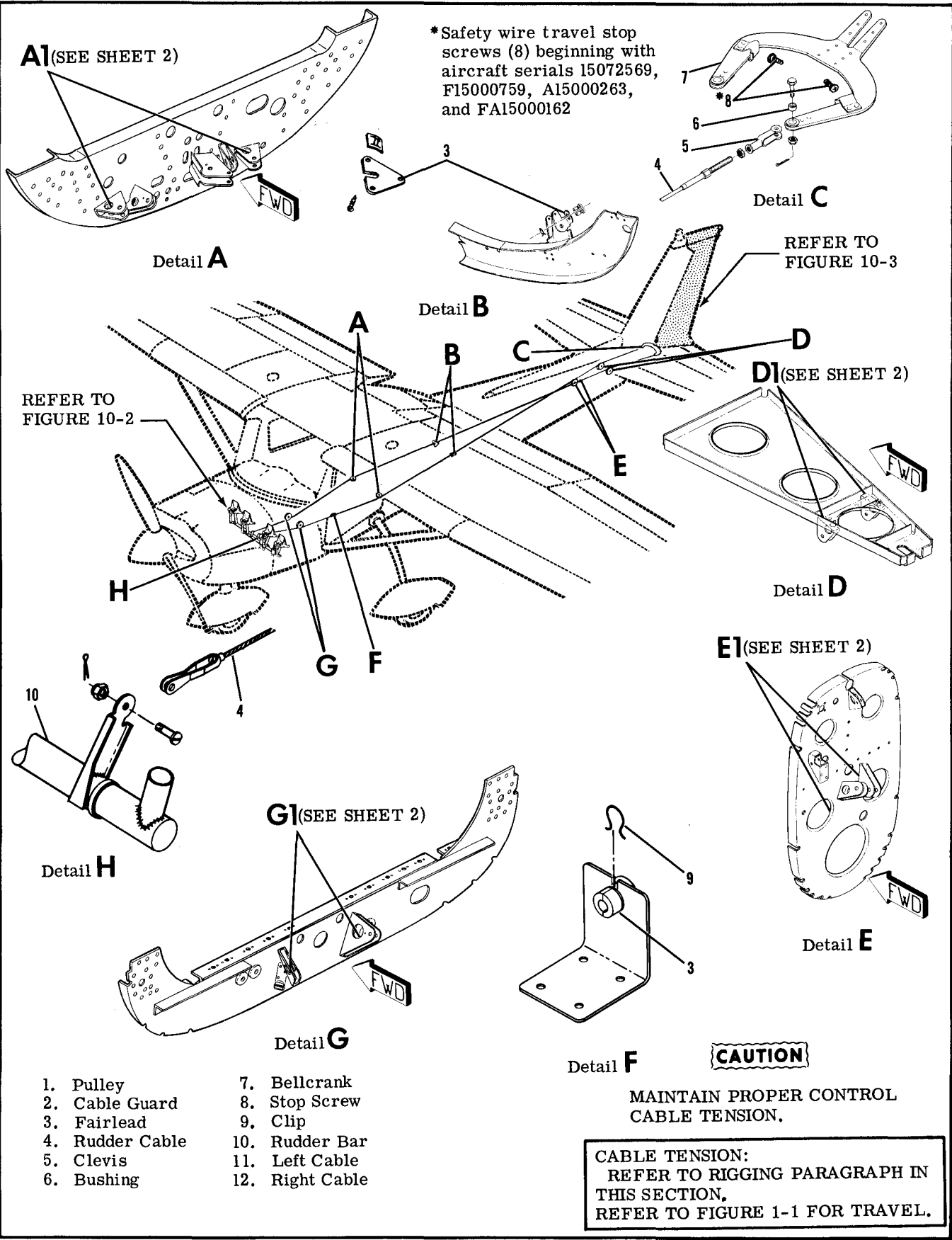

Figure 10-1. Rudder Control System (Sheet 1 of 2)

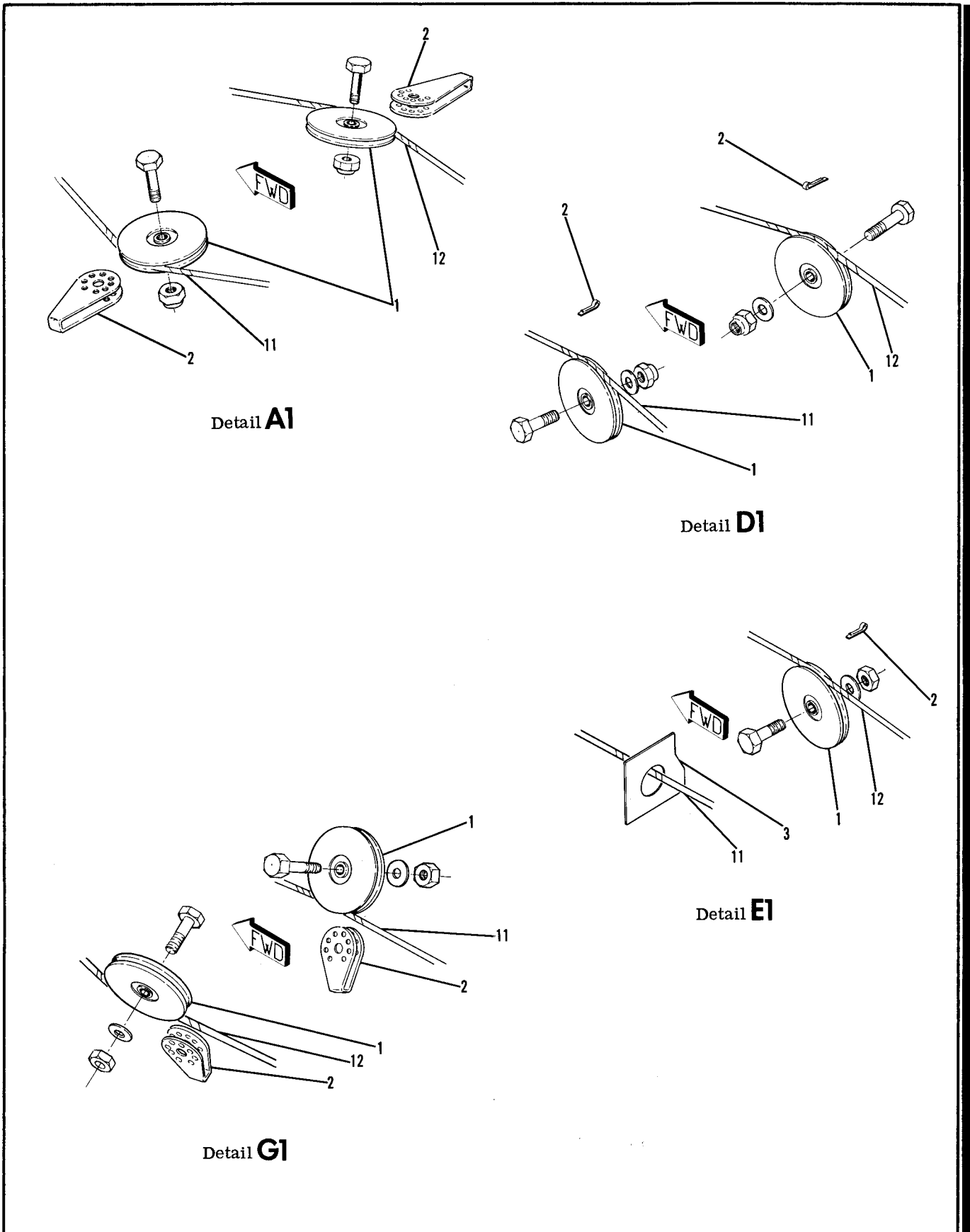

Figure 10-1. Rudder Control System (Sheet 2 of 2)

This page intentionally left blank.

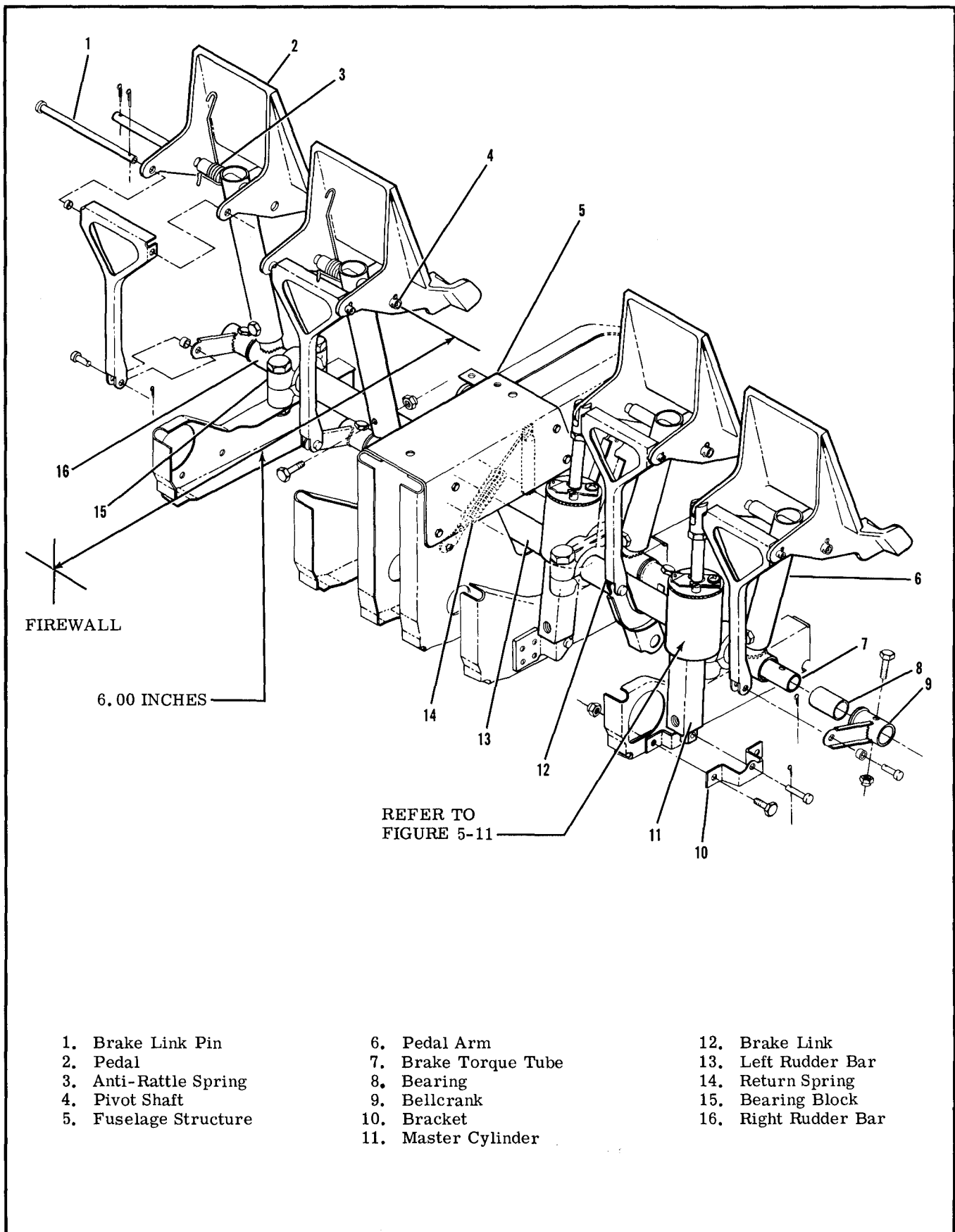

Figure 10-2. Rudder Pedals Installation

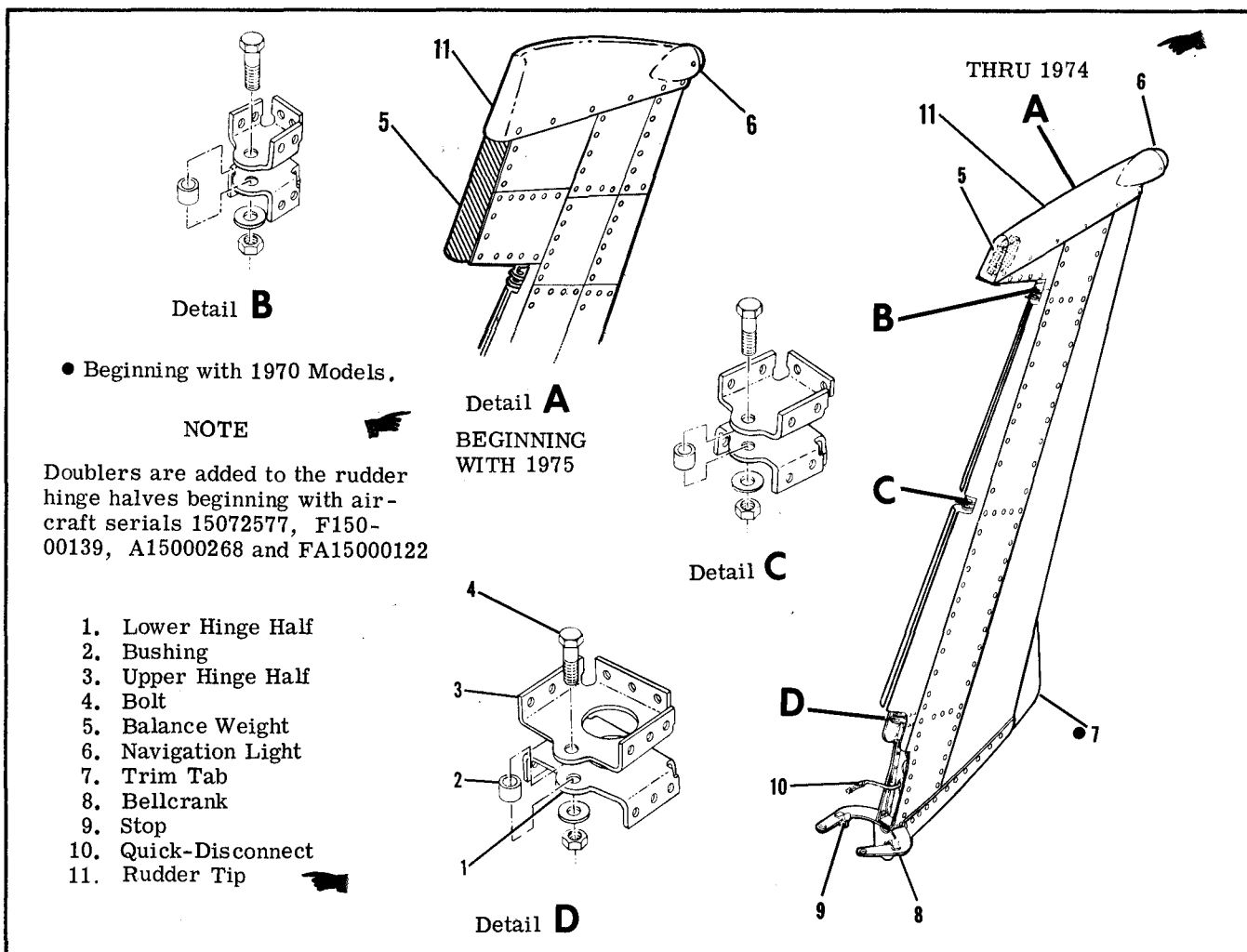

Figure 10-3. Rudder Installation

10-4. RUDDER PEDAL ASSEMBLY. (Refer to figure 10-2.)

10-5. REMOVAL AND INSTALLATION.

- a. Remove carpeting, shields and soundproofing from pedal and tunnel areas as necessary.
- b. Disconnect master cylinders (11) at pilot rudder pedals.
- c. Disconnect parking brake cables at master cylinders.
- d. Remove rudder pedals (2) and brake links (12).
- e. Relieve cable tension at clevises (index 5, figure 10-1).
- f. Disconnect cables, return springs and steering tubes from rudder bars.
- g. Remove bolts securing bearing blocks (15) and work rudder bars out of tunnel area.

NOTE

Rudder bar assemblies should be checked for excessive wear before installation. The bearing blocks are nylon and require no lubrication unless binding occurs. A few

drops of general purpose oil should eliminate such binding.

- h. Reverse preceding steps for installation. Rig system in accordance with applicable paragraph in this section, safety clevises and reinstall all items removed in step "a".

10-6. RUDDER. (Refer to figure 10-3.)

10-7. REMOVAL AND INSTALLATION.

- a. Disconnect tail navigation light quick-disconnect (10).
- b. Relieve cable tension at clevises (index 5, figure 10-1) and disconnect clevises from rudder bellcrank (8).
- c. With rudder supported, remove hinge bolts (4) and lift rudder free of vertical fin.
- d. Reverse preceding steps for installation. Rig system in accordance with applicable paragraph in this section and safety clevises.

10-8. REPAIR. Repair may be accomplished as outlined in Section 18. Hinge bushings may be replaced as necessary.

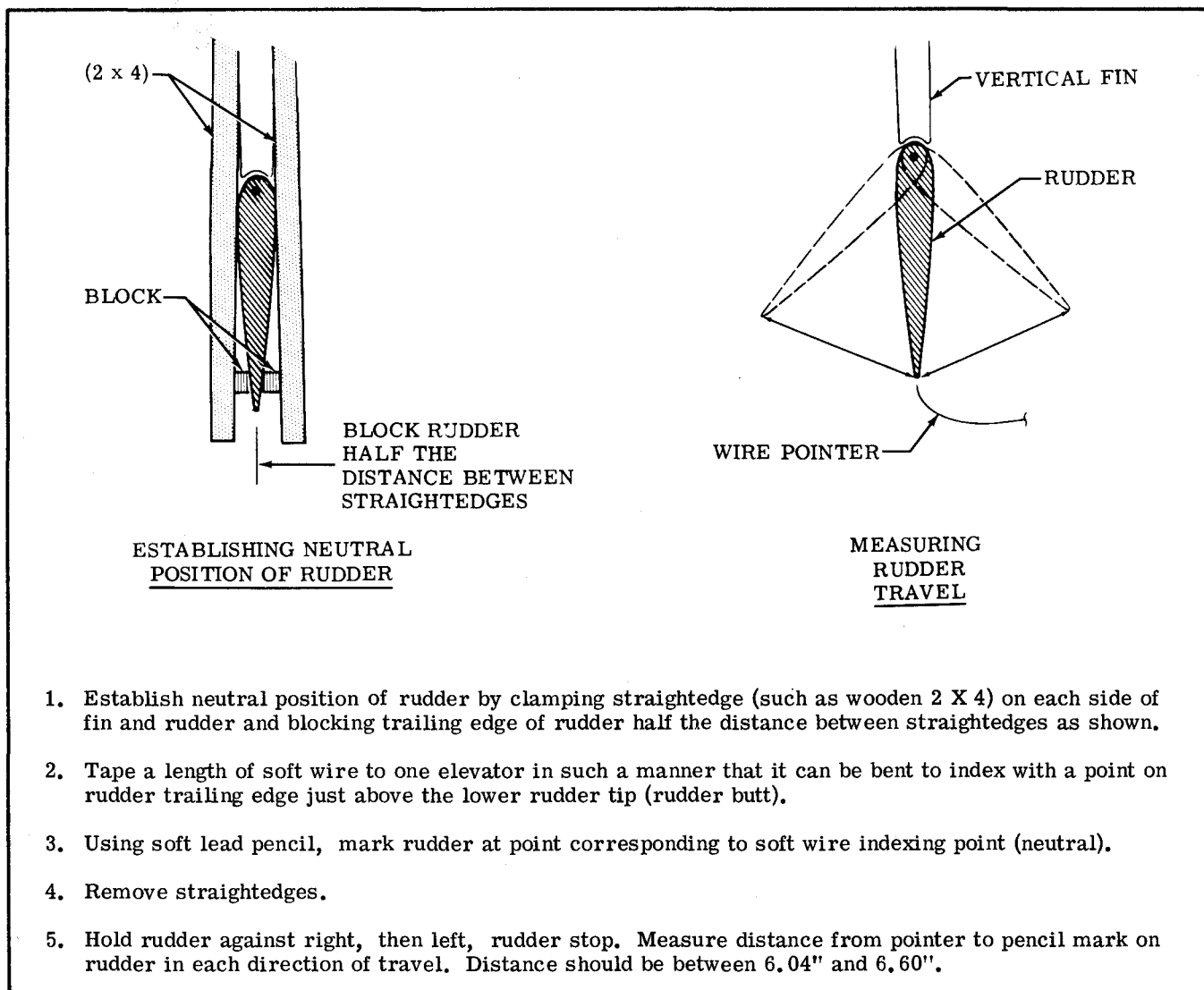

Figure 10-4. Checking Rudder Travel

10-9. CABLES AND PULLEYS. (Refer to figure 10-1.)

10-10. REMOVAL AND INSTALLATION.

- a. Remove seats, upholstery and access plates as necessary.
- b. Disconnect cable at rudder bar (10) and bellcrank (7).
- c. Remove cable guards, pulleys and fairleads as necessary to work cables free of aircraft.

NOTE

To ease routing of cables, a length of wire may be attached to end of cable before being withdrawn from aircraft. Leave wire in place, routed through structure, attach cable being installed and pull cable into position.

- d. After cable is routed in position, install pulleys fairleads and cable guards. Ensure cable is positioned in pulley groove before installing guard.
- e. Rig system in accordance with applicable para-

graph in this section, safety clevises and reinstall all items removed in step "a".

10-11. RIGGING. (Refer to figure 10-1.)

- a. Adjust travel stops (8) to attain travel specified in Section 1. Figure 10-4 illustrates correct travel and one method of checking.
- b. Disconnect nose wheel steering tubes (index 6, figure 5-6) from nose strut.
- c. Adjust cables at clevises (5) to align rudder and pedals in neutral position, 6.00 inches from firewall and pedal pivot shafts (index 4, figure 10-2). This step automatically determines cable tension through use of return springs (14).

NOTE

Due to thickness of insulation on firewall, it is recommended that a piece of 1/16 inch welding rod be ground to a sharp point and notched at the 6.00 inch dimension. Pierce insulation on firewall and use notch to measure proper dimension.

- d. Tie down or weight tail to raise nose wheel free of ground.
- e. Center nose gear against external stop.
- f. Extend steering tubes until free play is removed. **DO NOT COMPRESS SPRINGS.**
- g. Adjust steering tube rod ends to 1.25 inch dimension between steering arm assembly and bolt hole as illustrated in figure 5-9 and tighten jam nuts.
- h. Adjust steering tube clevises to align with rod end bearings.

NOTE

Extend steering tubes to seat rods against internal springs but do not attempt to preload these springs by shortening rod end clevises after alignment. Preload is built into steering tubes.

- i. Install clevises on rod ends.

NOTE

DO NOT adjust rudder trim with steering tubes. Degree of steering travel cannot be adjusted.

- j. Safety cable clevises and install all parts removed for access.

NOTE

On aircraft **WITHOUT** rudder trim tab, a flight test may determine the need for rigging rudder slightly off-center. Such correction should be made by tightening one rudder cable at clevis and loosening the opposite one an equal amount, thus keeping nosewheel steering system and rudder pedals aligned while rudder is shifted minutely. **DO NOT** attempt to rig rudder by adjusting nosewheel steering system.

On aircraft **WITH** rudder trim tab, flight test aircraft to determine if ground adjustment of fixed trim tab is necessary. **DO NOT** rig rudder "off-center" unless trim tab does not provide adequate correction.

WARNING

Be sure rudder moves in correct direction when operated by pedals.

SHOP NOTES:

SECTION 11

ENGINE

TABLE OF CONTENTS	Page
ENGINE COWLING	11-1
Removal and Installation	11-1
Cleaning and Inspection	11-2
Repair	11-2
ENGINE	11-3
Engine Data	11-3
Trouble Shooting	11-4
Removal	11-8
Cleaning	11-9
Accessories Removal	11-9
Inspection and Repair	11-9
Engine Build-Up	11-9
Installation	11-9
Flexible Fluid Hoses	11-10
Leak Test	11-10
Replacement	11-11
Static Run-Up Procedures	11-11
BAFFLES	11-11
Cleaning and Inspection	11-11
Removal and Installation	11-11
Repair	11-11
ENGINE MOUNT	11-11
Removal and Installation	11-11
Repair	11-11
Shock Mount Pads	11-12
ENGINE OIL SYSTEM	11-11
Trouble Shooting	11-13
Full-Flow Oil Filter	11-14
Filter Element Removal and Installation	11-14
Adapter Removal	11-17
Disassembly, Inspection and Assembly	11-17
Adapter Installation	11-17
ENGINE FUEL SYSTEM	11-17
Carburetor Removal and Installation	11-17
Adjustments	11-17
INDUCTION AIR SYSTEM	11-18
Removal and Installation	11-18
IGNITION SYSTEM	11-18
Magneto Removal	11-19
Internal Timing	11-19
Replacement Interval	11-19
Installation and Timing	11-19
Magneto Check	11-21
Maintenance	11-21
Spark Plugs	11-21
ENGINE CONTROLS	11-21
Rigging	11-22
Throttle	11-22
Mixture	11-22
Carburetor Heat	11-22A
STARTING SYSTEM	11-22A
Trouble Shooting	11-23
Removal and Installation	11-23
Primary Maintenance	11-24
EXHAUST SYSTEM	11-24
Removal	11-24
Inspection	11-24
Installation	11-24
EXTREME WEATHER MAINTENANCE	11-24
Cold Weather	11-24
Ground Service Receptacle	11-25
Hot Weather	11-25
Dusty Conditions	11-25
Seacoast and Humid Areas	11-25
Hand Cranking	11-25

11-1. ENGINE COWLING.

11-2. The engine cowling is comprised of an upper and lower cowl segment. A large access door on the upper cowl provides access to the fuel strainer drain, oil filler cap, and oil dipstick. Instead of attaching directly to the fuselage, the cowling attaches to shock mounts which are attached to the fuselage. Quick-release fasteners are used at the cowling-to-shock mount attach points to facilitate detachment of the cowling at the firewall. Screws fasten the upper and lower cowl segments together at the nose cap and quick-release fasteners are used along the side parting surfaces to hold cowling segments together.

11-3. REMOVAL AND INSTALLATION. Removal and installation of the engine cowling is accomplished by removing the attaching screws at the nose cap dividing surfaces and releasing the quick-release fasteners at side parting surfaces and at shock mounts of firewall. Disconnect electrical wiring to landing light in nose cap cowling. Disconnect any air duct and control linkage which interferes with removal of the cowling. When installing the cowling, be sure to connect any items disconnected during removal. Make sure that baffle seals are turned in the correct direction to confine and direct airflow around the engine. The vertically installed seals fold forward and the side seals fold upward.

NOTE

When new shock mounts or brackets are being installed, careful measurements should be made to position these parts correctly on the firewall. The service parts are not pre-drilled. Install shock mounts on brackets so that cowling and shock mount is correctly aligned. Sheet aluminum may be used as shims between bracket halves to provide cowling contour.

11-4. **CLEANING AND INSPECTION.** Wipe the inner surfaces of the cowling segments with a cloth saturated with cleaning solvent (Federal Specification PS-661 or equivalent). If the inside surface of the cowling is coated heavily with oil and dirt, allow solvent to soak until foreign material can be removed. Wash painted surfaces of cowling with a solution of

mild soap and water and rinse thoroughly. After washing, a coat of wax applied to painted surfaces is recommended to prolong paint life. After cleaning, inspect cowling for dents, cracks, and loose rivets or spot welds. Repair all defects to prevent spread of damage.

11-5. **REPAIR.** If cowling skins are extensively damaged, new complete sections of the cowling should be installed. Standard insert-type patches may be used for repair if repair parts are formed to fit contour of cowling. Small cracks may be stop-drilled and small dents straightened if they are reinforced on the inner surface with a doubler of the same material. Damaged reinforcement angles should be replaced with new parts. Due to their small size, new reinforcement angles are easier to install than to repair the damaged part.

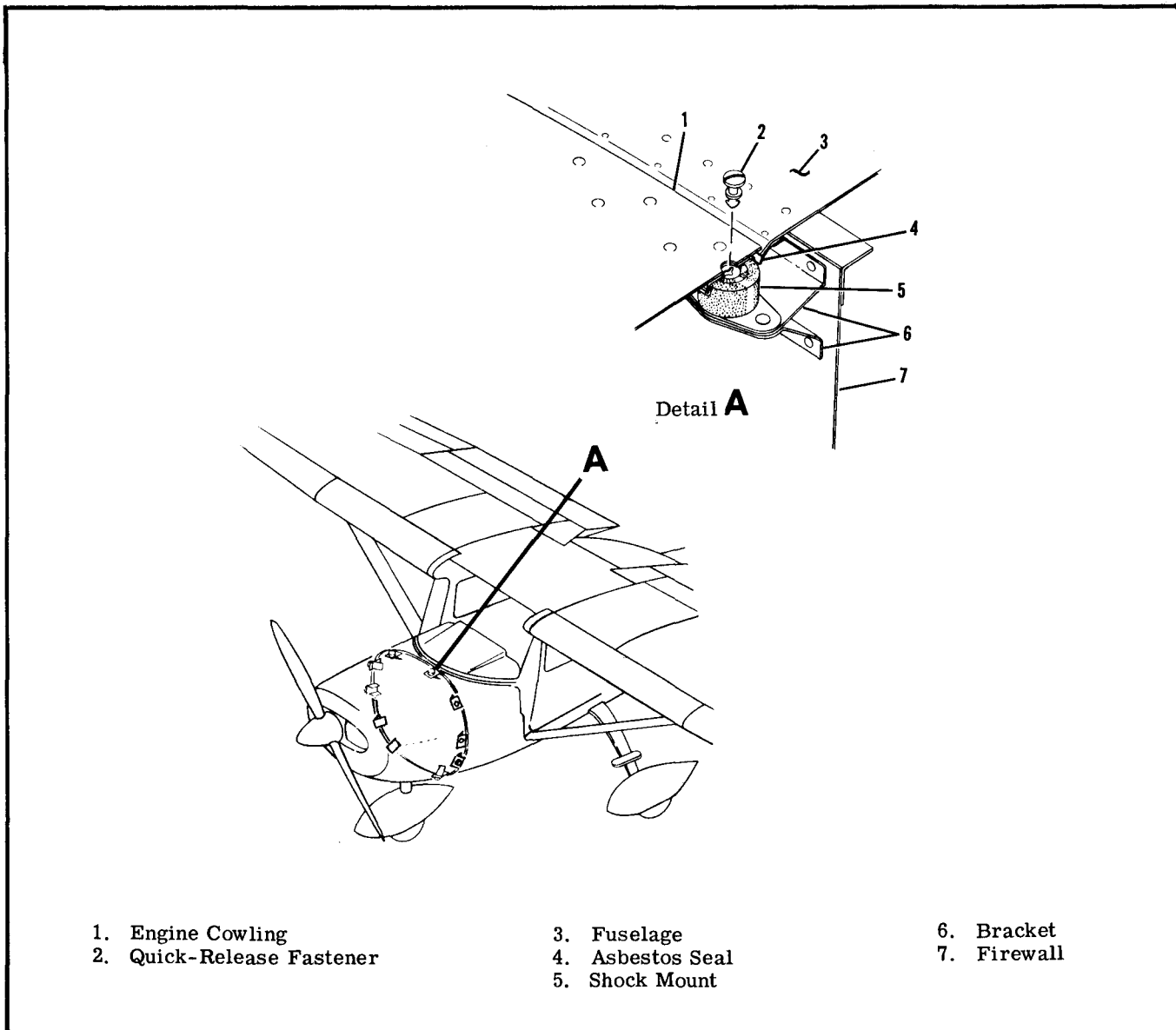

Figure 11-1. Engine Cowling

11-6. ENGINE.

11-7. An air-cooled, horizontal-opposed, low-compression, direct-drive, four-cylinder Continental O-200-A series engine driving a fixed-pitch propeller is used to power the aircraft. The cylinders, numbered from rear to front, are staggered to permit a separate throw on the crankshaft for each

connecting rod. The right rear cylinder is number 1 and cylinders on the right side are identified by odd numbers 1 and 3. The left rear cylinder is number 2 and the cylinders on the left side are identified as 2 and 4. Refer to paragraph 11-8 for detailed engine data. For repair and overhaul of the engine, refer to the applicable publication issued by the engine manufacturer.

11-8. ENGINE DATA.

Aircraft Model	150J, K, L & M
MODEL (Continental)	O-200-A
Rated Horsepower at RPM	100 at 2750
Number of Cylinders	4 Horizontally-Opposed
Displacement	200.91 Cubic Inches
Bore	4.0625 Inches
Stroke	3.875 Inches
Compression Ratio	7.00:1
Magnetos	Slick No. 4001
Right Magneto	Fires 24° (+1 -0°) BTC 1-3-2-4 Upper
Left Magneto	Fires 24° (+1 -0°) BTC 1-3-2-4 Lower
Firing Order	1-3-2-4
Spark Plugs	18MM (Refer to current Continental active factory approved spark plug chart)
Torque	330±30 Lb-In.
Carburetor (Marvel-Schebler)	MA-3-SPA
Alternator	14-Volt, 60-Ampere
Starter (12-Volt)	Automatic Engagement
Tachometer	Mechanical
Oil Sump Capacity	6 U. S. Quarts
With External Filter	7 U. S. Quarts
Oil Pressure (psi)	
Normal	30-60
Minimum Idling	10
Oil Temperature	
Normal Operating	Within Green Arc
Maximum	Red Line (225° F.)
Cylinder Head Temperature	
Normal Operating	Within Green Arc
Maximum	Red Line
Direction of Crankshaft Rotation (viewed from rear)	Clockwise
Dry Weight - with Accessories	200 lb (Weight is approximate and will vary with optional accessories installed)

11-9. TROUBLE SHOOTING.

TROUBLE	PROBABLE CAUSE	REMEDY
ENGINE WILL NOT START.	Fuel tank empty.	Fill with proper grade of gasoline.
	Improper use of starting procedures.	Review starting procedure.
	Fuel shut-off valve in OFF position.	Turn shut-off valve ON.
	Carburetor screen or fuel strainer plugged.	Remove and clean thoroughly. Remove moisture.
	Engine flooded.	Refer to paragraph 11-67.
	Defective ignition system.	Refer to paragraph 11-47.
	Excessive induction air leaks.	Correct the cause of leaks.
	Insufficient priming (puffs of white smoke and weak combustion).	Prime more. In cold weather draw plunger slowly back, push hard. Check pump output at priming jet.
	Defective magneto switch or grounded magneto "P" leads.	Check continuity. Repair or replace switch or wiring.
	Defective carburetor.	Repair or replace carburetor.
	Spark plugs fouled or improperly gapped.	Remove and clean: check gaps and insulators. Use new gaskets. Check cables to persistently fouled plugs. Replace defective plugs.
	Magneto impulse coupling failure.	Repair or install new magneto.
	Spark plugs loose.	Using new gaskets, tighten to specified torque.
	Water in fuel system.	Drain fuel tank sumps, fuel lines, fuel strainer and carburetor.
Excessive starter slippage.	Replace starter adapter.	
ENGINE WILL NOT RUN AT IDLING SPEED.	Idle speed or idle mixture incorrectly adjusted.	Refer to paragraph 11-37.
	Carburetor idling jet plugged.	Clean carburetor and fuel strainer.
	Air leak in intake manifold.	Tighten loose connections or replace damaged parts.
	Spark plugs fouled by oil escaping past piston rings.	Top overhaul engine.
ROUGH IDLING.	Idling mixture and/or mixture control improperly adjusted.	Refer to paragraph 11-37 and 11-53.

11-9. TROUBLE SHOOTING (Cont).

TROUBLE	PROBABLE CAUSE	REMEDY
ROUGH IDLING (cont).	Manual mixture control set for lean mixture.	Use full rich mixture for all ground operation.
	Fouled spark plugs.	Remove and clean. Adjust gaps. Test harness cables. Inspect contact breakers. If persistent, perform top overhaul.
	Priming pump leaking.	Repair or replace.
	Small air leak into induction system.	With mixture control at IDLE CUT-OFF, ignition switch OFF and throttle open, brush soap lather around tube joints and carburetor mount flange, one at a time, and turn propeller backwards to check for bubbles at points of leakage. Tighten connections or replace damaged gasket or seal.
	Leaking accelerating pump.	Repair or install new carburetor.
	Defective engine.	Check compression and listen for unusual engine noises. Engine repair is required.
ENGINE RUNS TOO LEAN AT CRUISING POWER.	Manual mixture control in wrong position.	Rig control in accordance with paragraph 11-53.
	Carburetor partially restricted.	Remove and clean.
ENGINE RUNS TOO RICH AT CRUISING POWER.	Manual mixture control in wrong position.	Rig control in accordance with paragraph 11-53.
	Restriction in air scoop or filter partially restricted.	Remove restriction. Clean filter.
	Carburetor air heat valve open.	Rig in accordance with paragraph 11-54.
ENGINE DOES NOT ACCELERATE PROPERLY.	Cold engine.	Warm up longer.
	Mixture control set for lean mixture.	Set control at full RICH position.
	Restriction in carburetor air intake.	Remove restriction and clean filter.
	Restriction in carburetor jets, low float level, plugged fuel screen.	Clean and repair carburetor.
	Idling setting too lean.	Refer to paragraph 11-37.

11-9. TROUBLE SHOOTING (Cont).

TROUBLE	PROBABLE CAUSE	REMEDY
ENGINE DOES NOT SHUT OFF WITH MANUAL MIXTURE CONTROL IN IDLE CUTOFF POSITION.	Fuel leakage thru primer.	Repair or install new primer.
	Linkage does not permit idle cutoff lever to reach OFF position.	Rig in accordance with paragraph 11-53.
ENGINE RUNS ROUGH AT HIGH SPEED.	Loose mounting bolts or rubber bushings defective.	Tighten bolts or replace mount bushings.
	Propeller out of balance.	Remove and balance.
	Spark plug gasket leaking, gap too large or insulator damaged.	Replace damaged parts.
	Ignition cable insulation damaged.	Test for leakage at high voltage. Replace damaged ignition lead.
	Excessively lean fuel-air mixture.	Clean fuel strainer, carburetor screen and carburetor main jet.
SLUGGISH OPERATION AND LOW POWER.	Throttle not opening completely.	Rig per paragraph 11-52.
	Spark plugs fouled or improperly gapped.	Remove, clean and regap or install new plugs.
	Carburetor air heat valve open.	Rig in accordance with paragraph 11-54.
	Damaged contact breaker or capacitor.	Overhaul magneto.
	Fuel-air mixture too rich or too lean.	Overhaul and adjust carburetor.
HIGH CYLINDER HEAD TEMPERATURE.	Low grade of fuel.	Drain and fill with correct grade of fuel. Refer to Section 2.
	Lean fuel-air mixture.	Refer to Owner's Manual for correct leaning procedure.
	Excessive carbon deposits in cylinder head and on pistons.	Install new cylinders and piston rings or new engine.
	Cylinder baffles loose or bent.	Check all baffles and correct.
	Dirt between cylinder fins.	Clean thoroughly.
HIGH OIL TEMPERATURE.	Low oil supply.	Replenish.
	Oil viscosity too high.	Refer to Section 2 for seasonal grades.
	Prolonged high speed operation on ground.	Hold ground running above 1500 rpm to a minimum.

11-9. TROUBLE SHOOTING (Cont).

TROUBLE	PROBABLE CAUSE	REMEDY
LOW OIL PRESSURE.	Low oil supply.	Replenish.
	Oil viscosity too low.	Drain and refill with correct seasonal grade. Refer to Section 2.
	Sludge or foreign material in relief valve.	Remove and clean valve parts.
	Foam in oil due to emulsification of alkaline solids.	Drain and refill with fresh oil. Refer to Section 2 for seasonal grade.
	Defective pressure gage.	Check with known good gage. Replace defective gage.
	Oil pump defective.	Remove and inspect. Examine engine. Metal particles from damaged pump may have entered engine oil passages.
	Oil congealed in gage line.	Disconnect line at engine and gage; flush with kerosene. Pre-fill line with kerosene and install.
	Oil pressure line broken, disconnected or pinched.	Inspect, replace or connect line.
	Internal leak, burned bearings, or damaged gasket.	Major overhaul.
OIL LEAK AT FRONT OF ENGINE.	Damaged crankshaft seal.	Replace.
OIL LEAK AT PUSH ROD HOUSING.	Damaged push rod housing oil seal.	Replace.
LOW COMPRESSION.	Cylinder wall worn out-of-round and choke reduced.	Replace cylinder and rings.
	Intake valves guides worn.	Top overhaul.
	Valves seats and faces worn.	Top overhaul.
	Piston rings excessively worn.	Top overhaul.
	Valves sticking in guides.	Top overhaul.

11-10. REMOVAL. If the engine is to be placed in storage or returned to the manufacturer for overhaul, proper preparatory steps should be taken prior to beginning the removal procedure. Refer to Indefinite Storage in Section 2 for preparation of the engine for storage. The following engine removal procedure is based upon the engine being removed from the aircraft with the engine mount attached to the firewall and all engine hose and lines being disconnected at the firewall. The reason for engine removal will determine where components are to be disconnected.

NOTE

Tag each item disconnected to aid in identifying wires, hose, lines and control linkage when engine is being installed. Protect openings, exposed as a result of removing or disconnecting units, against entry of foreign material by installing covers or sealing with tape.

- a. Place all cabin switches and fuel valves in the OFF position.
- b. Remove engine cowlings. (See paragraph 11-3.)
- c. Open battery circuit by disconnecting battery cable(s) at the battery. Insulate cable terminal(s) as a safety precaution.
- d. Disconnect ignition switch primary ("P") leads at the magnetos.

WARNING

The magneto is in a SWITCH ON condition when the switch wire is disconnected. Ground the magneto points or remove the high tension outlet plate from the magneto or disconnect spark plug lead wires at spark plugs to prevent accidental firing when the propeller is rotated.

- e. Drain engine oil from sump.
- f. Remove propeller and spinner. (See Section 13.)

NOTE

During the following procedures, remove any clamps which secure controls, wires, hose, or lines to the engine, engine mount, or attached brackets, so that they will not interfere with removal of the engine. Omit any of the items which are not present on a particular engine installation.

- g. Disconnect throttle and mixture control at carburetor. Pull these controls free of engine and engine mount, using care not to damage them by bending too sharply. Note position, size and number of attaching washers and spacers.
- h. Disconnect carburetor heat control from arm on carburetor air intake housing assembly. Remove clamps and pull control aft clear of the engine.
- i. Disconnect wires and cables as follows:

CAUTION

When disconnecting starter cable, do not permit starter terminal bolt to rotate. Rotation of the bolt could break the conductor between terminal and field coils causing the starter to be inoperative.

1. Starter electrical cable at starter.
2. Electrical wires and wire shielding ground at alternator.
3. Tachometer drive shaft at adapter on engine.
4. Remove all clamps attaching wires and cables to the engine or engine mount. Pull all wires and cables aft to clear the engine.
- j. Disconnect and cap or plug lines and hose as follows:
 1. Vacuum hose at firewall.

WARNING

Residual fuel and oil draining from disconnected lines and hose is a fire hazard. Use care to prevent accumulation of such fuel and oil when lines or hose are disconnected.

2. Oil pressure hose at firewall.
3. Oil temperature bulb at engine.
4. Primer line to engine at firewall.
5. Fuel hose to engine at fuel strainer on firewall.
6. Remove all clamps attaching lines and hose to engine or engine mount which interferes with engine removal from engine mount.

CAUTION

Attach a tail stand to the tail tie-down fitting before removing the engine. The loss of engine weight will allow the tail to drop. Do not raise engine higher than necessary when removing engine-to-mount bolts. Raising the engine too high places a strain on the attach bolts and hinders their removal.

- k. Attach a hoist to the lifting lug on top of the engine and take up engine weight on hoist.
 1. Remove bolts attaching engine-to-mount. Note direction of bolt installation and position and numbers of washers. Balance the engine by hand as the last of the bolts are removed. Remove ground straps at lower mount legs as bolts are removed.

CAUTION

Hoist engine slowly and ascertain that all items attaching engine and accessories to engine mount and airframe are disconnected.

- m. Carefully guide disconnected components out of engine assembly.

11-11. CLEANING. The engine may be cleaned with a suitable solvent, such as Stoddard solvent, or equivalent, then dried thoroughly.

CAUTION

Particular care should be given to electrical equipment before cleaning. Solvent should not be allowed to enter magnets, starter, alternator, and the like. Hence, protect these components before saturating the engine with solvent. Cover any fuel, oil and air openings on the engine and accessories before washing the engine with solvent. Caustic cleaning solutions should be used cautiously and should always be properly neutralized after their use.

11-12. ACCESSORIES REMOVAL. Removal of engine accessories for overhaul or for engine replacement involves stripping the engine of parts, accessories, and components to reduce the engine assembly to the bare engine. During removal, carefully examine removed items and tag defective parts for repair or replacement with a new part.

NOTE

Items easily confused with similar items should be tagged to provide a means of identification when being installed on a new engine. All openings exposed by the removal of an item should be closed by installing a suitable cover or cap over the opening. This will prevent entry of foreign particles. If suitable covers are not available, tape may be used to cover the opening.

11-13. INSPECTION. For specific items to be inspected refer to engine manufacturer's manual.

- Visually inspect the engine for loose nuts, bolts, cracks and fin damage.
- Inspect baffles, baffle seals and brackets for cracks, deterioration and breakage.
- Inspect all hoses for internal swelling, chafing through protective plys, cuts, breaks, stiffness, damaged threads and loose connections. Excessive heat on hoses will cause them to become brittle and easily broken. Hoses and lines are most likely to crack or break near the end fittings and support points.
- Inspect for color bleaching of the end fittings or severe discoloration of the hoses.

NOTE

Avoid excessive flexing and sharp bends when examining hoses for stiffness.

- All flexible fluid carrying hoses in the engine compartment should be replaced at engine overhaul or every five years, whichever occurs first.
- For major engine repairs, refer to the manufacturer's overhaul and repair manual.

11-14. ENGINE BUILD-UP. Engine build-up consists of installation of parts, accessories and components to the basic engine to build-up an engine unit ready for installation on the aircraft. All safety wire, lockwashers, palnuts, elastic stop nuts, gaskets and rubber connections should be new parts.

11-15. INSTALLATION. Before installing the engine on the aircraft, install any items that were removed from the engine after it was removed from the aircraft.

NOTE

Remove all protective covers, plugs, caps and identification tags as each item is connected or installed.

- Hoist engine assembly to a point near the engine mount.
- Route controls, lines and hose in place as the engine is positioned near the engine mount.
- Install shock-mounts as shown in figure 11-2 and install engine-to-mount bolts. Be sure ground straps are in place at lower engine mount. Tighten engine-to-mount bolts to torque value shown in figure 11-2.
- Remove hoist and stand placed under tail tie-down fitting.
- Route throttle and mixture controls to the carburetor and connect, using washers and spacers as noted in step "g" of paragraph 11-10.

NOTE

Throughout the aircraft fuel system, from the tanks to the carburetor, use Never-Seez RAS-4, (Snap-On Tools Corporation, Kenosha, Wisconsin) or MIL-T-5544 thread compound as a thread lubricant or to seal a leaking connection. Apply compound to male fitting, omitting the first two threads. Always be sure that the compound, the residue of a previously used compound, or any other foreign material does not enter the fuel system.

- Connect lines and hose as follows:
 - Fuel hose at fuel strainer on firewall.
 - Primer line to engine at firewall.
 - Oil temperature bulb at engine.
 - Oil pressure hose at firewall.
 - Install all clamps attaching lines and hose to engine, engine mount, or attached brackets.
- Connect wires and cables as follows:
 - Electrical wires and wire shielding ground at alternator.

CAUTION

When connecting starter cable, do not permit starter terminal bolt to rotate. Rotation of the bolt could break the conductor between terminal and field coils causing the starter to be inoperative.

- Starter electrical cable at starter.

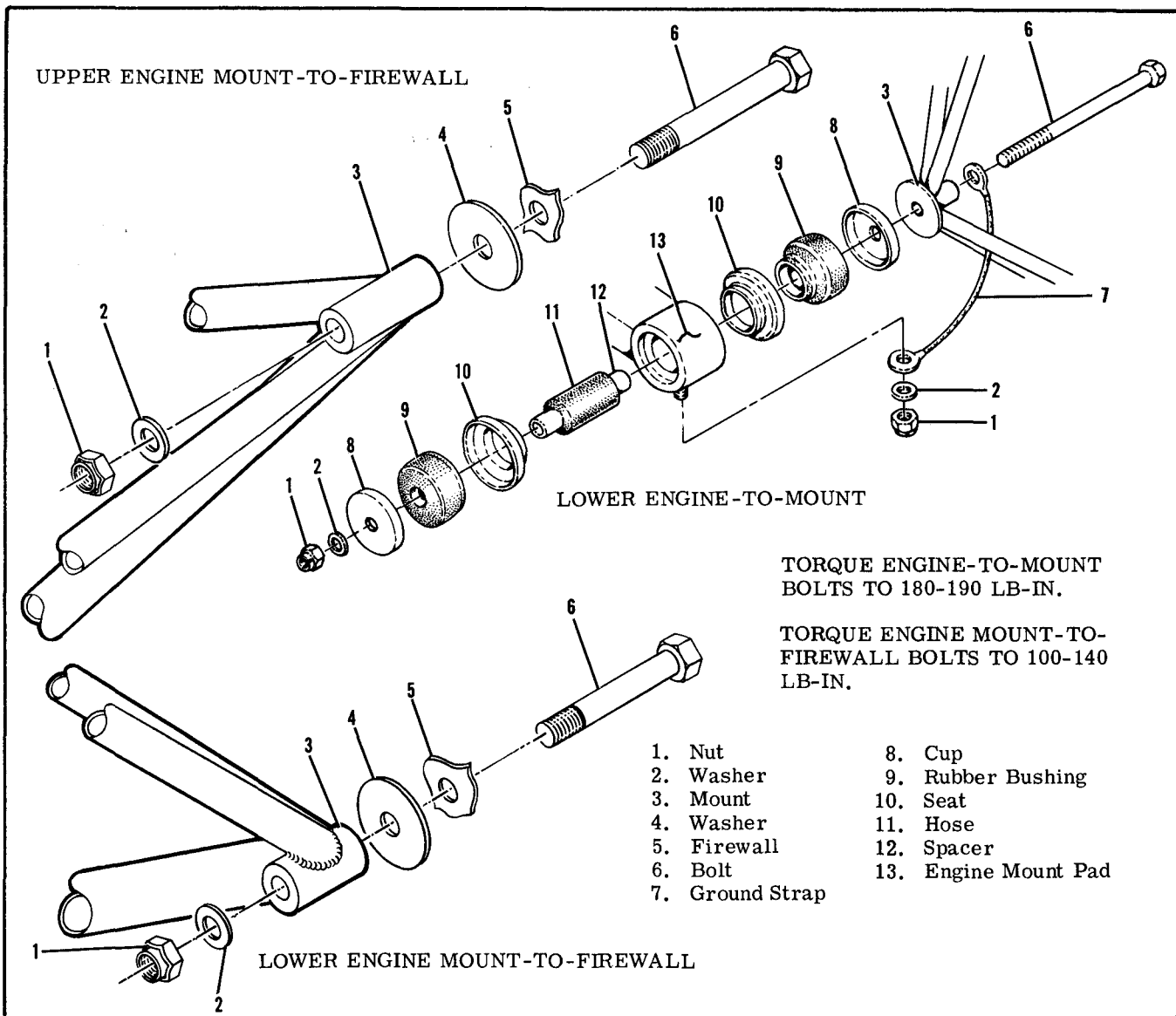

Figure 11-2. Engine Mount Details

3. Tachometer drive shaft at engine. Be sure drive cable engages drive in adapter on engine. Torque housing attach nut to 100 lb-in.

4. Install all clamps attaching wires and cables to engine, engine mount, or attached brackets.

h. Route carburetor heat control to arm on carburetor air intake housing assembly. Install clamps and rig in accordance with paragraph 11-54.

i. Install propeller and spinner. (Refer to Section 13 for affected aircraft model.)

j. Make a magneto switch wire ground-out and continuity check. Connect magneto switch wires to the magnetos.

WARNING

Be sure magneto switch is in OFF position when connecting switch wires to magnetos.

k. Service engine with proper grade and quantity

of engine oil. Refer to paragraph 2-11C if engine is new, newly overhauled, or has been in storage.

l. Make sure all switches are in the OFF position, and connect battery cable (s) to battery.

m. Rig throttle, mixture and carburetor heat controls in accordance with paragraph 11-51 through 11-54.

n. Check engine installation for security, correct routing of controls, lines, hose and tightness of all components.

o. Install engine cowling. Clean and install carburetor air filter. Be sure all hot and cold air ducts are installed and connected.

p. Perform engine run-up and make final adjustments on engine controls.

11-15A. FLEXIBLE FLUID HOSES.

11-15B. LEAK TEST.

a. After each 50 hours of engine operation, all flex-

ible fluid hoses in the engine compartment should be checked for leaks as follows:

1. Examine the exterior of hoses for evidence of leakage or wetness.
2. Hoses found leaking should be replaced.
3. Refer to paragraph 11-13 for detailed inspection procedures for flexible hoses.

11-15C. REPLACEMENT

- a. Hoses should not be twisted on installation. Pressure applied to a twisted hose may cause failure or loosening of the nut.
- b. Provide as large a bend radius as possible.
- c. Hoses should have a minimum of one-half inch clearance from other lines, ducts, hoses or surrounding objects or be butterfly clamped to them.
- d. Rubber hoses will take a permanent set during extended use in service. Straightening a hose with a bend having a permanent set will result in hose cracking. Care should be taken during removal so that hose is not bent excessively, and during reinstallation to assure hose is returned to its original position.
- e. Refer to AC 43.13-1, Chapter 10, for additional installation procedures for flexible fluid hose assemblies.

11-15D. STATIC RUN-UP PROCEDURES. In a case of suspected low engine power, a static RPM run-up should be conducted as follows:

- a. Run-up engine, using take-off power and mixture settings, with the aircraft facing 90° right and then left to the wind direction.
- b. Record the RPM obtained in each run-up position.

NOTE

Daily changes in atmospheric pressure, temperature and humidity will have a slight effect on static run-up.

c. Average the results of the RPM obtained. Thru 1974 models it should be within 50 RPM of 2550 RPM. Beginning with 1975 models it should be within 50 RPM of 2510 RPM.

d. If the average results of the RPM obtained are lower than stated above, the following recommended checks may be performed to determine a possible deficiency.

1. Check carburetor heat control for proper rigging. If partially open it would cause a slight power loss.
2. Check magneto timing, spark plugs and ignition harness for settings and conditions.
3. Check condition of induction air filter. Clean if necessary.
4. Perform an engine compression check. (Refer to engine Manufacturer's Manual).

11-16. BAFFLES.

11-17. The sheet metal baffles installed on the engine directs the cooling air flow around the cylinders and other engine components to provide optimum engine cooling. These baffles incorporate rubber-asbestos composition seals at points of contact with

the engine cowling to help confine and direct cooling air to the desired area. The baffles, air blast tubes and air scoops are accurately positioned to maintain engine cooling efficiency and their removal will cause improper air circulation and engine overheating.

11-18. CLEANING AND INSPECTION. Engine baffles should be cleaned with a suitable solvent to remove dirt and oil.

NOTE

The rubber-asbestos seals are oil and grease resistant but should not be soaked in solvent for long periods.

Inspect baffles for cracks in the metal and for loose and/or torn seals. Replace defective parts.

11-19. REMOVAL AND INSTALLATION. Removal and installation on the various baffle segments is possible with the cowling removed. Be sure that any replacement baffles and seals are installed correctly and that they seal to direct the cooling air in the correct direction.

11-20. REPAIR. Baffles ordinarily should be replaced if damaged or cracked. However, small plate reinforcements riveted to the baffle will often prove satisfactory both to the strength and cooling requirements of the unit.

11-21. ENGINE MOUNT.

11-22. The engine mount is composed of sections of tubing welded together and reinforced with welded gussets. The purpose of the engine mount is to support the engine and attach the engine to the airframe. The engine is attached to the mount with shock-mount assemblies which absorb engine vibrations. The engine mount also supports the nose gear shock strut.

11-23. REMOVAL AND INSTALLATION. Removal of the engine mount necessitates removal of the engine and nose landing gear, followed by removal of the bolts attaching the engine mount to the fuselage structure. When installing an engine mount, tighten mount-to-fuselage bolts to the torque value listed in figure 11-2. Install landing gear as outlined in paragraph 5-23. The engine, engine mount and nose gear may be removed from the aircraft and then engine and nose gear removed from the mount.

11-24. REPAIR. Perform engine mount repair as outlined in Section 18. The mount should be painted with heat-resistant black enamel after welding or whenever original finish has been removed.

11-25. SHOCK-MOUNT PADS. The rubber and metal shock-mounts are designed to reduce transmission of engine vibrations to the airframe. The rubber parts should be wiped with a clean dry cloth. Inspect metal parts for cracks and excessive wear due to aging and deterioration. Inspect rubber parts

for swelling, cracking, or a pronounced set of the part. Install with new parts all parts that show evidence of wear or damage.

11-26. ENGINE OIL SYSTEM.

11-27. A wet-sump, pressure-lubricating oil system is used in the O-200-A series engines. Oil in the sump passes through a sump pick-up tube, through the suction screen in the tube, to the suction side of the oil pump. From the pressure side of the oil pump, oil is fed through the pressure oil screen, or external full-flow oil filter, into the left oil gallery. The oil flows forward through the left gallery, across the crankcase, through the passages connected by the camshaft front journal groove, and into the right gallery. The oil pressure relief valve

closes the rear end of the right gallery. The galleries pressure-feed the main bearings, cam shaft bearings, and hydraulic tappets. Connecting rod bearings are lubricated from the main bearings through drilled passages in the crankshaft. Valve mechanisms are lubricated through hollow push-rods from the tappets. Cylinder walls, piston pins, and connecting rod bushings are spray-lubricated by oil escaping from the connecting rod and main bearings. Gears in the crankcase cover cavity are lubricated by spray from the rear main and rear camshaft bearings. Drilled passages from the crossover oil gallery lubricates the vacuum pump adapter pad mounted at the front lower side of the engine. Throughout the engine, oil is returned to the sump by gravity. The external full-flow oil filter is discussed in paragraph 11-29.

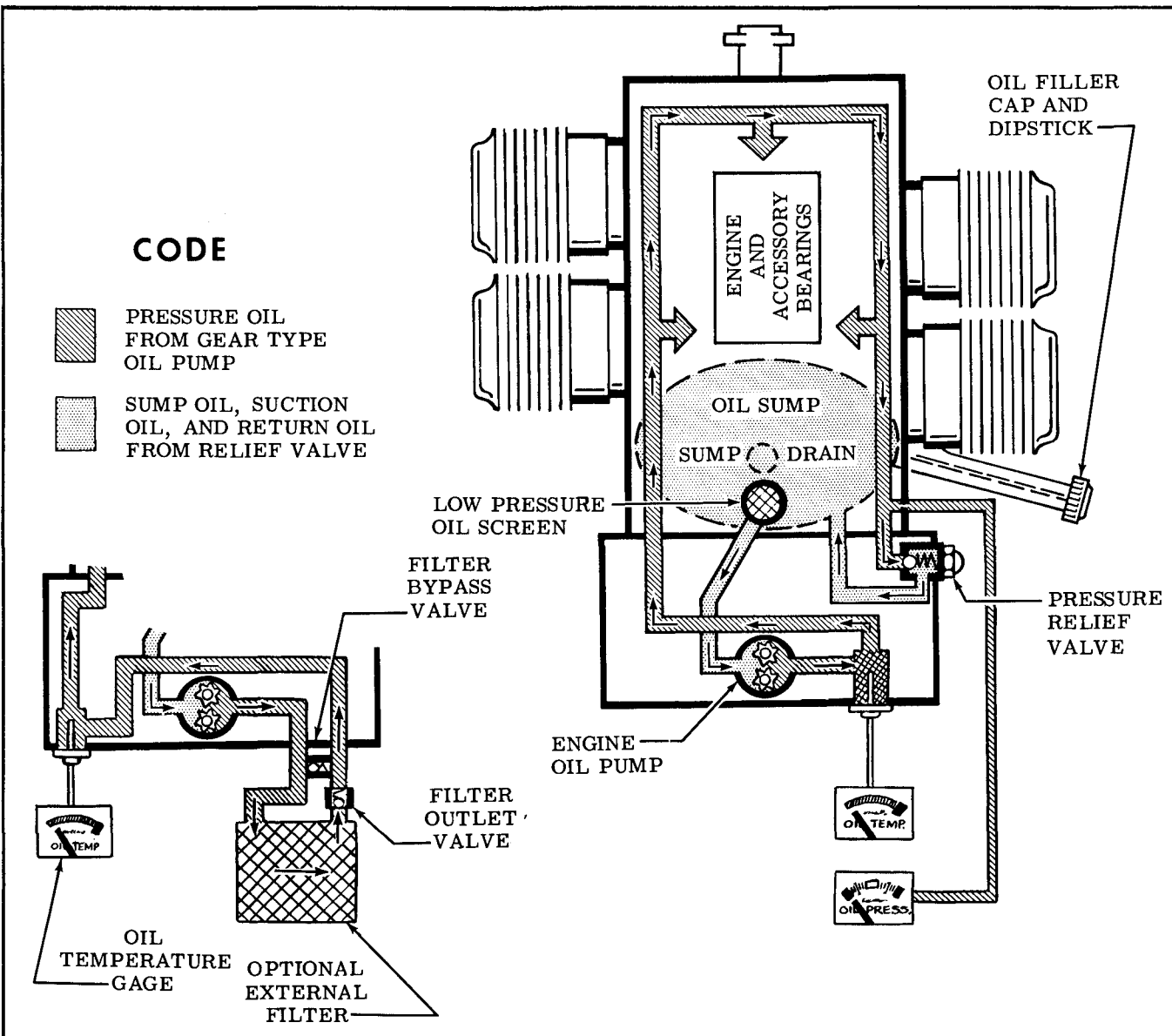

Figure 11-3. Engine Oil Schematic

11-28. TROUBLE SHOOTING.

TROUBLE	PROBABLE CAUSE	REMEDY
NO OIL PRESSURE.	No oil in sump.	Fill sump with proper grade and quantity of oil. Refer to Section 2.
	Oil pressure line broken, disconnected or pinched.	Replace or connect.
	Oil pump defective.	Remove and inspect. Examine engine. Metal particles from damaged pump may have entered engine oil passages.
	Defective oil pressure gage.	Check with another gage. Replace if defective.
	Oil congealed in gage line.	Disconnect line at engine and gage; flush with kerosene. Pre-fill with kerosene and install.
	Relief valve defective.	Remove and check for dirty or defective parts. Clean and install; replace defective parts.
LOW OIL PRESSURE.	Low oil supply.	Replenish. Refer to Section 2.
	Low viscosity oil.	Drain sump and refill with proper grade and quantity of oil.
	Oil pressure relief valve spring weak or broken. Dirt on seat.	Replace weak or broken spring. Clean plunger and seat.
	Defective oil pump.	Remove and inspect. Examine engine. Metal particles from damaged pump may have entered engine oil passages.
	Secondary result of high oil temperature.	Observe oil temperature gage for high indication. Determine and correct reason for high oil temperature.
	Plugged oil screen.	Remove and clean screen.
	Oil pressure gage defective.	Check with another gage. Replace if defective.
	Oil pressure relief valve plunger sticking.	Remove and clean plunger.
Oil pump suction tube screen plugged or internal oil leak.	Engine overhaul required.	
HIGH OIL PRESSURE.	High viscosity oil.	Drain sump and refill with proper grade and quantity of oil.
	Defective oil pressure gage.	Check with another gage. Replace if defective.
	Relief valve defective.	Remove and check for dirty or defective parts. Clean and install; replace defective parts.

11-28. TROUBLE SHOOTING (Cont).

TROUBLE	PROBABLE CAUSE	REMEDY
LOW OIL TEMPERATURE.	Defective oil temperature gage or temperature bulb.	Check with another gage. If reading is normal, aircraft gage is defective. If reading is similar temperature bulb is defective. Replace defective part/or parts.
HIGH OIL TEMPERATURE.	Excessive rate of climb.	Avoid low airspeed.
	Lean fuel-air mixture.	Avoid excessive lean mixture operation.
	Vernatherm control valve damaged or held open by solid matter.	Remove. Clean valve and seat. If still inoperative, replace.
	Low oil supply.	Replenish.
	Oil viscosity too high. Dirty or diluted oil.	Drain and fill sump with proper grade and quantity.
	Prolonged high speed operation on the ground.	Hold ground running above 1500 rpm to a minimum.
	Defective oil temperature gage.	Check with another gage. If second reading is normal, aircraft gage is defective. Replace gage.
Defective oil temperature bulb.	Check for correct oil pressure, oil level and cylinder head temperature. If they are correct, check oil temperature gage for being defective; if similar reading is observed, bulb is defective. Replace bulb.	

11-29. FULL-FLOW OIL FILTER. An external oil filter may be installed on the engine. The filter and filter adapter replaces the internal oil pressure screen. Provisions are provided in the oil filter adapter cover for the oil temperature bulb. The filter adapter incorporates a bypass valve. If the filter element should become clogged, the bypass valve will open, allowing pressure oil to flow to the engine oil passages.

11-30. FILTER ELEMENT REMOVAL AND INSTALLATION. (See figure 11-4.)

NOTE

New filter element kits are available from the Cessna Service Parts Center.

- a. Remove engine cowling as necessary for access.
- b. Remove both safety wires from filter can and unscrew hollow stud to detach filter assembly from adapter as a unit. Remove from aircraft discarding upper gasket. Oil will drain from filter assembly as assembly is removed from adapter.
- c. Press downward on hollow stud to remove from

- d. Lift lid from can, and discard lower gasket.
- e. Pull filter element from can.

NOTE

Before discarding removed filter element, remove the outer perforated paper cover; using a sharp knife, cut through the folds of the filter element at both ends, close to the metal caps. Then carefully unfold the pleated element and examine the material trapped in the filter element for evidence of internal engine damage such as chips or particles from bearings. In new or newly overhauled engines, some small particles or metallic shavings might be found, these are generally of no consequence and should not be confused with particles produced by impacting, abrasion, or pressure. Evidence of internal engine damage found in the oil filter element justifies further examination to determine the cause.

- f. Wash lid, hollow stud and can in cleaning solvent and dry with compressed air.

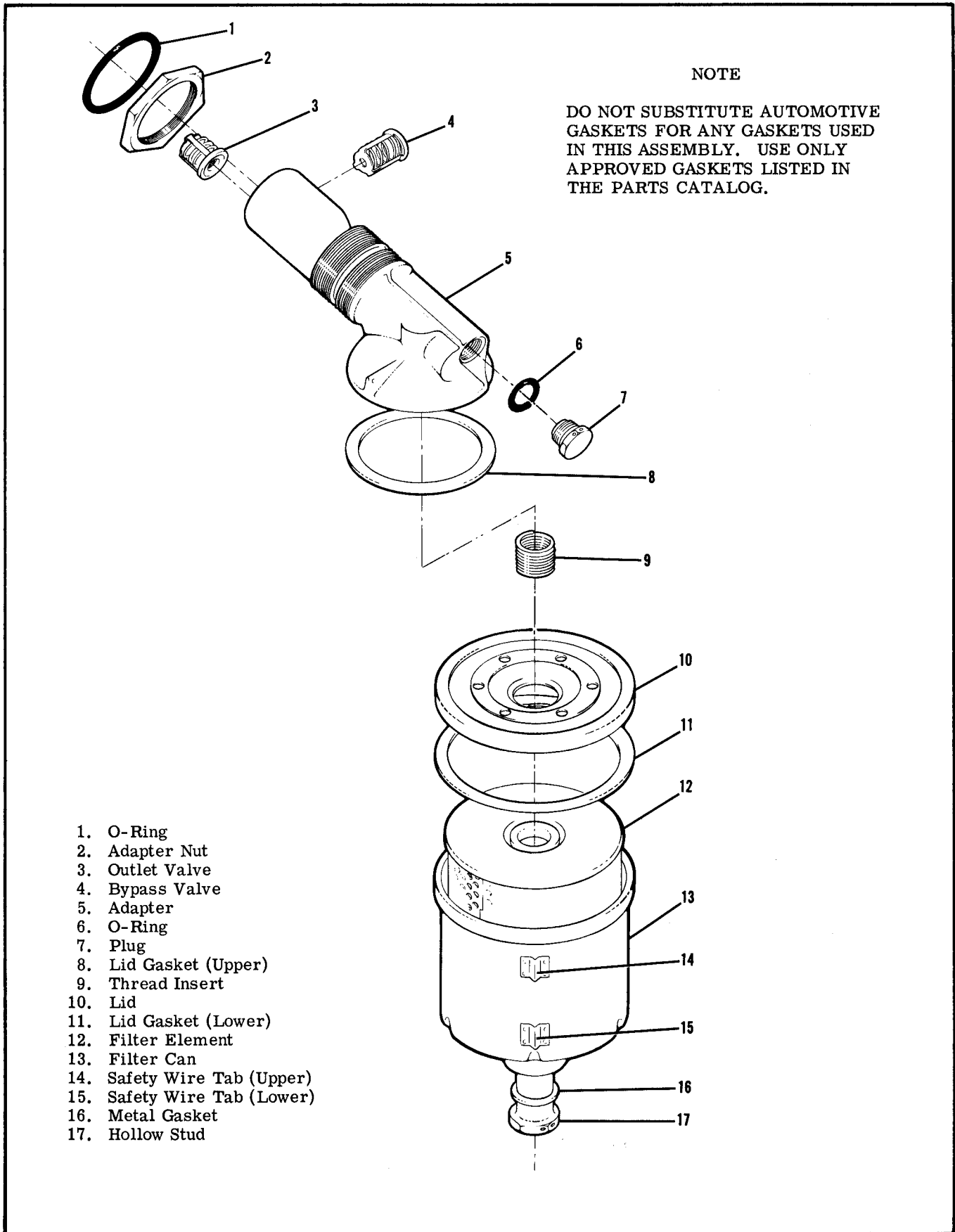

1. O-Ring
2. Adapter Nut
3. Outlet Valve
4. Bypass Valve
5. Adapter
6. O-Ring
7. Plug
8. Lid Gasket (Upper)
9. Thread Insert
10. Lid
11. Lid Gasket (Lower)
12. Filter Element
13. Filter Can
14. Safety Wire Tab (Upper)
15. Safety Wire Tab (Lower)
16. Metal Gasket
17. Hollow Stud

Figure 11-4. Full-Flow Oil Filter

NOTE

When installing a new filter element, it is important that all gaskets are clean, lubricated, and positioned properly, and that the correct amount of torque is applied to the filter hollow stud. If the hollow stud is under-torqued, oil leakage will occur. If the hollow stud is over-torqued, the filter can might possibly be deformed, again causing oil leakage.

Lubricate rubber grommets in each end of new filter element, upper and lower gaskets, and metal gasket with clean engine oil or general purpose grease before installing. Dry gaskets can cause false torque readings, again resulting in oil leakage.

Before assembly, place a straightedge across bottom of filter can. Check for distortion or out-of-flat condition greater than 0.010 inch. Install a new can if either of these conditions exists.

After installing a new upper gasket on the lid, turn lid over. If gasket falls, try a different gasket and repeat test. If this gasket falls off, install a new lid.

g. Inspect adapter gasket seat for gouges, deep scratches, wrench marks, and mutilation. If any of these conditions are found, install a new adapter.

h. Place a new filter element in can and insert hollow stud with a new metal gasket in place, through the can and filter element.

i. Position a new lower gasket inside flange of lid. Place lid in position on can.

j. Install filter assembly on adapter with a new upper gasket in place. While holding can to prevent it from turning, tighten hollow stud and torque to 20-25 lb-ft (240-300 lb-in), using a torque wrench.

k. Install parts removed for access, and service the engine with proper grade and quantity of engine oil. One additional quart of oil is required each time filter element is changed.

l. Start engine and check for proper oil pressure. Check for oil leaks after warming up engine.

m. Again check for oil leakage after engine has been run at a high power setting (preferably a flight around the field).

n. Check to make sure that the filter has not been in contact with adjacent parts due to engine torque.

o. While engine is still warm, recheck torque on hollow stud, then safety hollow stud to bracket on can, and safety adapter nut to other bracket on filter can.

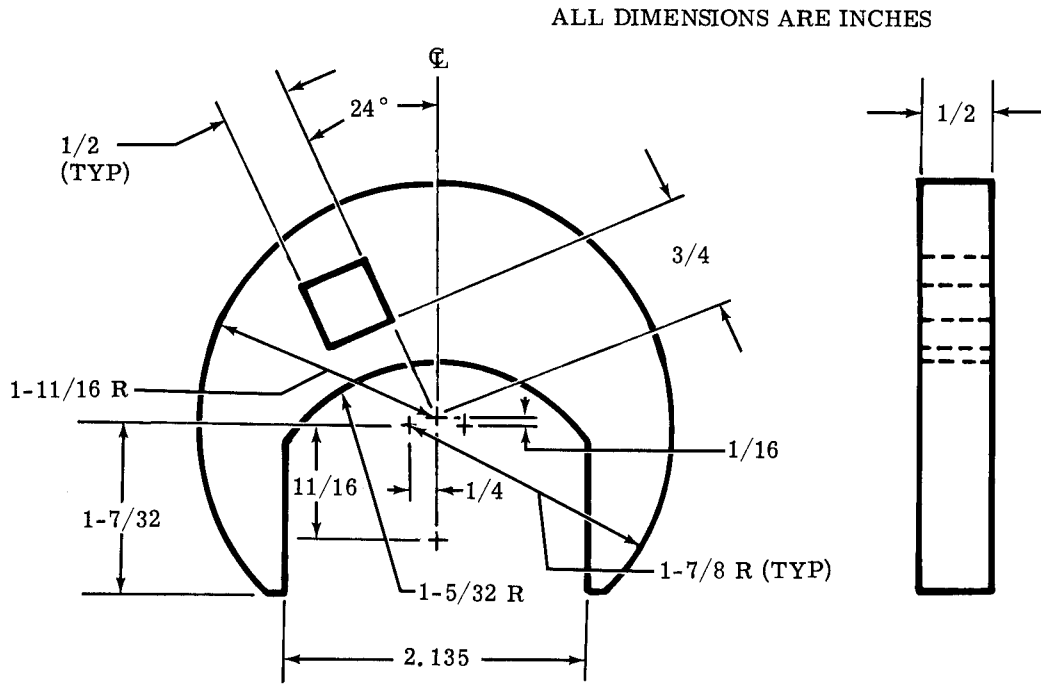

MATERIAL: 4130 (Rc. 35-38)

Figure 11-5. Wrench Adapter Fabrication

- 11-31. ADAPTER REMOVAL. (See figure 11-4.)
- a. Remove filter can as outlined in paragraph 11-30.

NOTE

A special wrench adapter (Part No. SE709) for the adapter nut, is available from the Cessna Service Parts Center, or one may be made as shown in figure 11-5.

- b. Note angular position of adapter, then remove safety wire and loosen adapter nut.
- c. Unscrew adapter and remove adapter from engine. Discard adapter O-ring.

11-32. DISASSEMBLY, INSPECTION, AND ASSEMBLY. Figure 11-4 shows the relative position of the internal parts of the filter adapter and may be used as a guide during installation of parts. The bypass valve is to be installed as a complete unit, with the valve being staked three places. A new helio-type thread insert in the adapter may be installed although special tools are required. Follow instructions of the tool manufacturer for their use. Inspect threads on adapter and in engine for damage. Clean adapter in solvent and dry with compressed air. Ascertain that all passages in the adapter are open and free of foreign material. Also, check that bypass valve is seated properly.

11-33. ADAPTER INSTALLATION.

- a. Assemble adapter nut and new O-ring on adapter in sequence illustrated in figure 11-4.
- b. Lubricate O-ring on adapter with clean engine oil. Tighten adapter nut until O-ring is centered in its groove on the adapter.
- c. Apply an anti-seize compound sparingly to the adapter threads, then simultaneously screw adapter and adapter nut into engine until O-ring seats against engine boss without turning adapter nut. Rotate adapter to approximate angular position noted during removal of adapter. Do not tighten adapter nut at this time.
- d. Temporarily install filter assembly on adapter, and position so adequate clearance with adjacent parts is attained. Maintaining this position of the adapter, tighten adapter nut to 50-60 lb-ft (600-700 lb-in) and safety. Use a torque wrench when tightening adapter nut.
- e. Using new gaskets, install filter assembly as outlined in paragraph 11-30. Be sure to service engine oil system.

11-34. ENGINE FUEL SYSTEM.

11-35. The engine is equipped with a carburetor mounted at the lower side of the engine. The carburetor is of the plain-tube fixed-jet type, and has such features as an enclosed accelerating pump mechanism, simplified fuel passages to prevent vapor locking, idle cut-off to prevent starting of the engine accidentally, and manual mixture control for leaning. For overhaul and repair of the carburetor refer to the manufacturer's overhaul and repair manual.

11-36. CARBURETOR REMOVAL AND INSTALLATION.

- a. Place fuel shut-off valve in the OFF position.
- b. Remove engine cowling and drain fuel strainer.
- c. Disconnect flexible ducts from each side of intake airbox.
- d. Disconnect carburetor heat control at arm on airbox. Remove clamp securing control to airbox.
- e. Remove bolts and screws attaching airbox to carburetor and engine bracket.
- f. Disconnect throttle and mixture controls from arms on carburetor. Note EXACT position, size and number of washers and spacers for reference on re-installation.
- g. Disconnect and plug fuel line at carburetor.
- h. Remove nuts and washers attaching carburetor to intake manifold. Remove carburetor and mounting gasket.
- i. Reverse the preceding steps for reinstallation. Use new gaskets when installing carburetor. Rig controls in accordance with paragraphs 11-52, 11-53 and 11-54. Check carburetor throttle arm to idle stop arm attachment for security and proper safetying at each normal engine inspection in accordance with figure 11-8.

11-37. IDLE SPEED AND MIXTURE ADJUSTMENT should be accomplished after the engine has been warmed up. Since idle rpm may be affected by idle mixture adjustment, it may be necessary to readjust idle rpm after setting the idle mixture correctly.

- a. Set the throttle stop screw to obtain between 575 and 600 rpm, with throttle control pulled full out against idle stop.

NOTE

Engine idle speed may vary among different engines. An engine should idle smoothly, without excessive vibration, and the idle speed should be high enough to maintain idling oil pressure and to preclude any possibility of engine stoppage in flight when the throttle is closed.

- b. Advance throttle to increase engine speed to 1000 rpm.
- c. Pull mixture control knob slowly and steadily toward the idle cut-off position, observing tachometer, then return control full in position before engine stops.
- d. Adjust mixture adjusting screw at upper end of carburetor intake throat to obtain a slight and momentary gain of 25 rpm maximum at 1000 rpm engine speed as mixture control is moved from full in toward idle cut-off position. Return control to full rich to prevent engine stoppage.
- e. If mixture is set too LEAN, engine speed will drop immediately, thus requiring a richer mixture. Turn adjusting screw out (counterclockwise) for a richer mixture.
- f. If mixture is set too RICH, engine speed will increase above 25 rpm, thus requiring a leaner mixture. Turn adjusting screw in (clockwise) for a leaner mixture.

NOTE

After each adjustment to the idle mixture, run engine up to approximately 2000 rpm to clear engine of excess fuel to obtain a correct idle speed.

11-38. INDUCTION AIR SYSTEM.

11-39. Ram air to the engine enters the induction airbox through an opening in the forward part of the lower engine cowling nose cap. The air is filtered through a filter which is located at the opening in the nose cap. From the induction airbox the filtered air is directed to the inlet of the carburetor, mounted on the lower side of the engine, and through the carburetor, where fuel is mixed with the air, to the intake manifold. From the intake manifold, the fuel-air mixture is distributed to each cylinder by separate intake pipes. The intake pipes are attached to the intake manifold with hose and clamps and to the cylinder with a two bolt flange which is sealed with a gasket. The induction airbox contains a valve, operated by the carburetor heat control in the cabin, which permits air from an exhaust heated source to be selected in the event carburetor icing or filter icing should be encountered.

11-40. REMOVAL AND INSTALLATION.

a. Remove airbox and carburetor as outlined in paragraph 11-36.

b. Remove intake pipes by disconnecting hose and removing nuts and washers attaching pipes to cylinders.

c. Installation of the system is the reverse of the preceding steps. Use new gaskets at installation.

11-41. IGNITION SYSTEM.

11-42. Sealed, lightweight Slick magnetos are used on the engine. Both magnetos are equipped with impulse couplings. The magnetos MUST NOT BE DISASSEMBLED. Internal timing is fixed and the breaker points are not adjustable. Timing marks are provided on the distributor gear and distributor block, visible through the air vent holes, for timing to the engine. A timing hole is provided in the bottom of the magneto adjacent to the magneto flange. A timing pin (or 0.093 inch 6-penny nail) can be inserted through this timing hole into the mating hole in the magneto rotor shaft to lock the magneto approximately in the proper firing position. Slick lightweight ignition harness is used with the lightweight magnetos. For ignition harness repair refer to the manufacturer's Service Manual.

WARNING

During all magneto maintenance, always take proper precautions to make sure the engine can not fire or start when the propeller is moved.

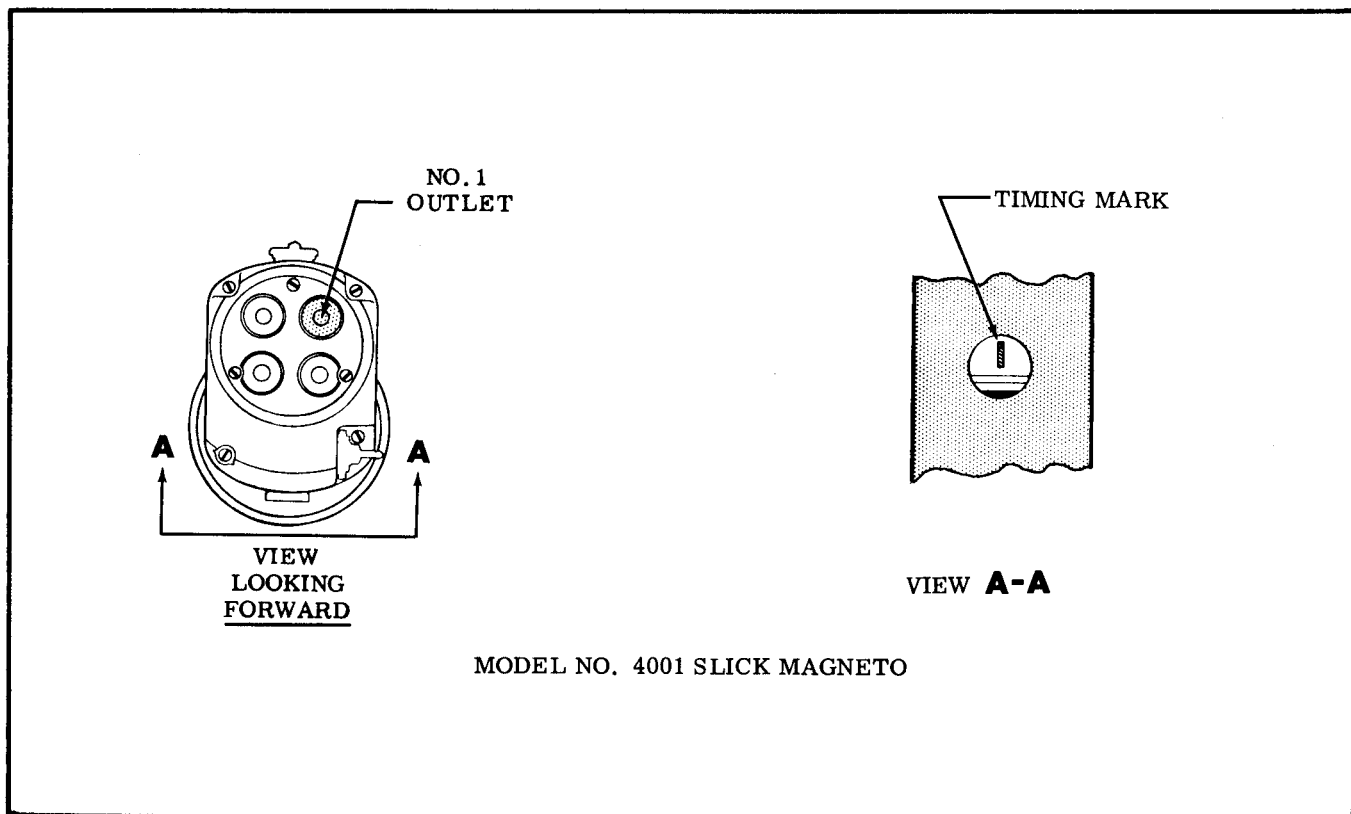

MODEL NO. 4001 SLICK MAGNETO

Figure 11-6. No. 1 Magneto Outlet

11-43. MAGNETO REMOVAL. Remove high-tension outlet plate, disconnect primary lead, and remove nuts and washers securing magneto to the engine. Note the approximate angular position at which the magneto is installed, then remove the magneto.

11-44. INTERNAL TIMING. Internal timing is accomplished during manufacture of the magneto. Since these magnetos are NOT TO BE DISASSEMBLED, there is no internal timing involved.

11-45. REPLACEMENT INTERVAL. These magnetos cannot be overhauled in the field. The coil, capacitor, and breaker assembly are non-replacable. As a good maintenance practice, and to have the benefit of good ignition at all times, it is recommended that the magnetos be removed at 900 hours of magneto time, and install new exchange magnetos.

11-46. MAGNETO INSTALLATION AND TIMING TO ENGINE. The magneto must be installed with its timing marks correctly aligned, with number one cylinder on its compression stroke, and with the number one piston at its advanced firing position. Refer to paragraph 11-8 for the advanced firing position of number one piston. To locate the compression stroke of the number one cylinder, remove the lower spark plug from number two, three, and four cylinder and remove the upper spark plug from number one cylinder. Place the thumb of one hand over the spark plug hole of number one cylinder and rotate crankshaft in the direction of normal rotation until the compression stroke is indicated by positive pressure inside the cylinder lifting the thumb off the spark plug hole. After the compression stroke is obtained, locate number one piston at its advanced firing position. Locating the advanced firing position of number one piston may be obtained by rotating the crankshaft opposite to its normal direction of rotation until it is approximately 30 degrees before top center (BTC) on the compression stroke of number one cylinder. Then, rotate crankshaft in normal direction of rotation to align the correct timing mark on the outer surface of the crankshaft flange, with the parting surface of the crankcase below the crankshaft as the reference point, making sure the final motion of the crankshaft is in the direction of normal rotation.

NOTE

Various other methods and equipment may be used to arrive at the number one piston advanced firing position. One such method is: An accurate top center indicator which screws into a spark plug mounting hole, and a pendulum pointer mounted on a 360-degree timing disc may be used. The timing disc should be adapted to fit over the end of the propeller spinner in such a manner that it may be rotated as necessary.

In all cases, it must be definitely determined that No. 1 cylinder is at the correct firing position, on its compression stroke, when the crankshaft is rotated in its normal direction of rotation.

After the engine has been placed to the correct firing position, install and time magneto to the engine in the following manner.

- a. Remove the timing (vent) plug from the bottom of the magneto. The vent plug in the top of the magneto need not be removed.
- b. Rotate magneto shaft until timing mark on rotor is visible through the vent plug hole. Impulse coupling pawls must be depressed to turn magneto shaft in normal direction of rotation.
- c. Establish that the magneto is at number one firing position. It is possible for the timing mark to be visible while firing position is 180 degrees from number one firing position.

NOTE

It is necessary to "spark" the magneto to establish the correct firing position. The outlet plate with spark plug leads must be installed on the magneto. Hold number one spark plug lead (see figure 11-6) close to magneto case, or ground the magneto and hold the number one spark plug lead close to a good ground. Rotate impulse coupling in normal direction of rotation until a spark occurs at this lead. (Impulse coupling pawls must be depressed to turn magneto shaft in normal direction of rotation.) Turn impulse coupling backward a few degrees, until timing marks on rotor is centered in vent plug hole and install timing pin (or 0.093 inch 6-penny nail) through hole in bottom of magneto next to the flange and into the mating hole in the rotor shaft. This locks the magneto approximately in firing position while installing it on the engine.

- d. Keep timing mark centered in vent plug hole during installation.
- e. Be sure magneto gaskets are in place and that engine is in correct firing position, then install magneto (s) at the angle noted during removal, tighten mounting nuts finger tight.

CAUTION

Remove timing pin from magneto, if installed. Be sure to remove this pin before rotating crankshaft.

- f. Connect one lead of timing light to the capacitor terminal at the rear of the magneto and ground lead of timing light to a good ground.
- g. Rotate propeller opposite to normal direction of rotation a few degrees (approximately 5 degrees) to close magneto contact points.

NOTE

Do not rotate propeller back far enough to engage impulse coupling, or propeller will have to be rotated in normal direction of rotation until impulse coupling releases, then backed up a few degrees before the firing position.

- h. Slowly advance propeller (tap forward with minute movements as firing position is approached)

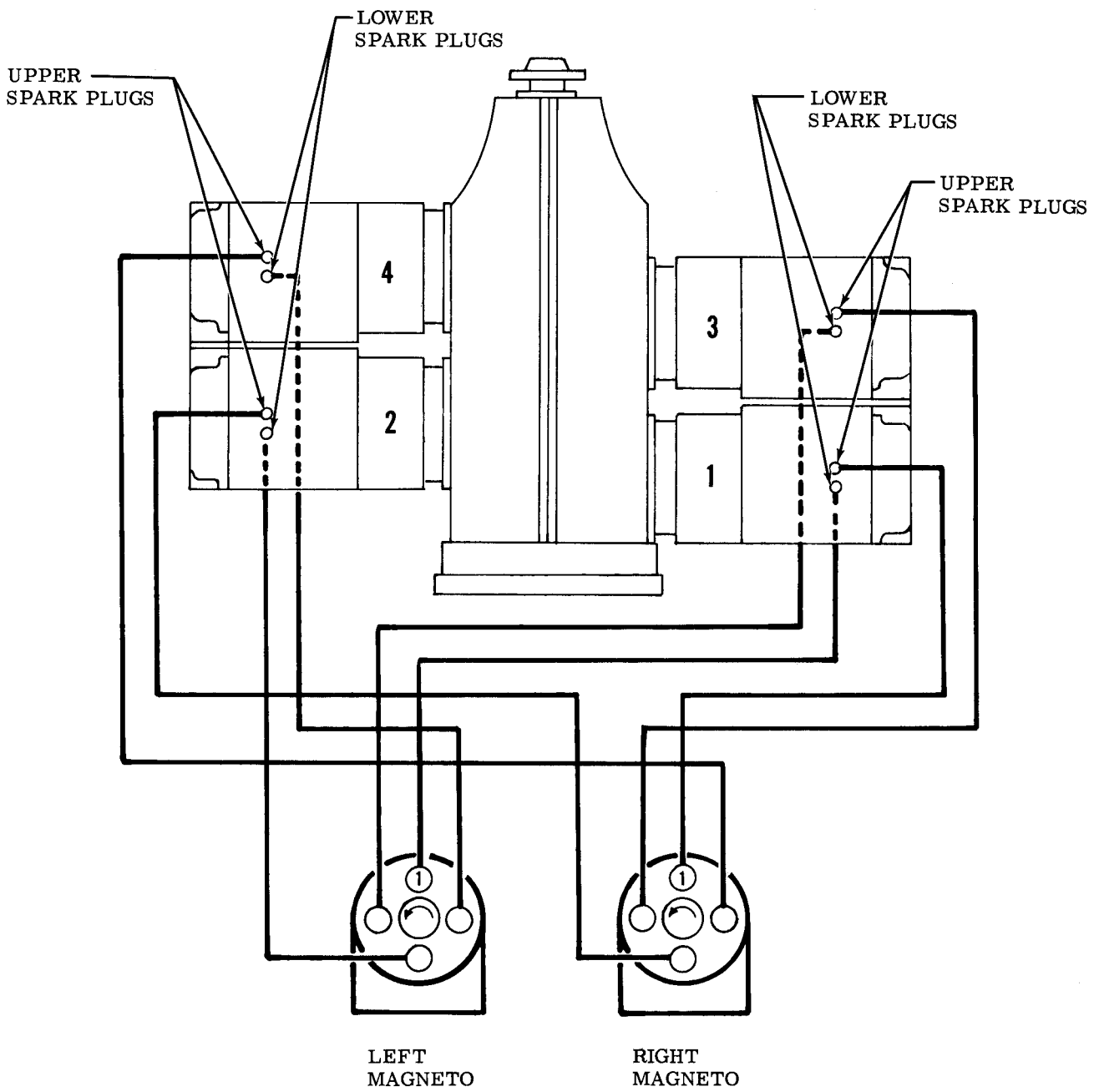

FIRING ORDER 1-3-2-4

Figure 11-7. Ignition Schematic

in normal direction of rotation until timing light indicates position at which contact points break. The contact points should break at the advanced firing position of number one cylinder. Loosen mounting nuts slightly and rotate magneto case to make contact points break at the correct position. Tighten mounting nuts.

i. After tightening magneto mounting nuts, recheck timing. Make sure both magnetos are set to fire at the same time. Remove timing equipment and connect spark plug leads and ignition switch leads.

NOTE

Beginning with the number one outlet, the magneto fires at each successive outlet in a counterclockwise direction, looking at the outlets. Connect number one magneto outlet to number one cylinder spark plug lead, number two outlet to the next cylinder to fire, etc. Engine firing order is listed in paragraph 11-8.

11-46A. **MAGNETO CHECK.** Advanced timing settings in some cases, is the result of the erroneous practice of bumping magnetos up in timing in order to reduce RPM drop on single ignition. **NEVER ADVANCE TIMING BEYOND SPECIFICATIONS IN ORDER TO REDUCE RPM DROP.** Too much importance is being attached to RPM drop in single ignition. RPM drop on single ignition is a natural characteristic of dual ignition design. The purpose of the following magneto check is to determine that all cylinders are firing. If all cylinders are not firing, the engine will run extremely rough and cause for investigation will be quite apparent. The amount of RPM drop is not necessarily significant and will be influenced by ambient air temperature, humidity, airport altitude, etc. In fact, absence of RPM drop should be cause for suspicion that the magneto timing has been bumped up and is set in advance of the setting specified. Magneto checks should be performed on a comparative basis between individual right and left magneto performance.

a. Start and run engine until the oil and cylinder head temperatures are in the normal operating ranges.

b. Advance engine speed to 1700 rpm.

c. Turn the ignition switch to the "R" position and note the rpm drop, then return the switch to the "BOTH" position to clear the opposite set of plugs.

d. Turn the switch to the "L" position and note the rpm drop, then return the switch to the "BOTH" position.

e. The rpm drop should not exceed 150 rpm on either magneto or show greater than 75 rpm differential between magnetos. A smooth rpm drop-off past normal is usually a sign of a too lean or too rich mixture. A sharp rpm drop-off past normal is usually a sign of a fouled plug, a defective harness lead or out of time. If there is doubt concerning operation of the ignition system, rpm checks at a leaner mixture setting or at higher engine speeds will usually confirm whether a deficiency exists.

NOTE

An absence of rpm drop may be an indication of faulty grounding of one side of the ignition system, a disconnected ground lead at magneto or possibly the magneto timing is set too far in advance.

11-47. **MAINTENANCE.** Magneto-to-engine timing should be checked at the first 50 hours, first 100 hours, and thereafter at each 200 hours. If timing to the engine is not within plus zero degrees and minus two degrees, the magneto should be timed to the engine.

NOTE

If ignition trouble should develop, spark plugs and ignition wiring should be checked first. If the trouble appears definitely to be associated with a magneto, the following may be used to help disclose the source of trouble.

a. Remove high-tension outlet plate and check distributor block for moisture.

b. If any moisture is evident, lightly wipe with a soft, dry, lint-free cloth. Reinstall outlet plate.

NOTE

Since these magnetos **MUST NOT BE DISASSEMBLED**, new magnetos should be installed if the moisture check does not remedy the trouble.

11-48. **SPARK PLUGS.** Two 18-mm spark plugs are installed in each cylinder and screw into heli-coil type thread inserts. The spark plugs are shielded to prevent spark plug noise in the radio and the spark plugs have an internal resistor to provide longer terminal life. Spark plug life will vary with operating conditions. A spark plug that is kept clean and properly gapped will give better and longer service than one that is allowed to collect lead deposits and is improperly gapped. The correct spark plug and gap setting is given in paragraph 11-8.

NOTE

At each 100-hour inspection, remove, clean, inspect, and regap all spark plugs. Install lower spark plugs in upper portion of cylinder and install upper spark plugs in lower portion of cylinders at each 100-hour inspection. Since deterioration of lower spark plugs is usually more rapid than that of the upper spark plugs, rotating them helps prolong spark plug life.

11-49. **ENGINE CONTROLS.**

11-50. Engine controls of the push-pull type include the throttle, mixture, and carburetor heat controls. The engine controls are equipped with position-locking devices which prevent vibration-induced "creeping" of the controls.

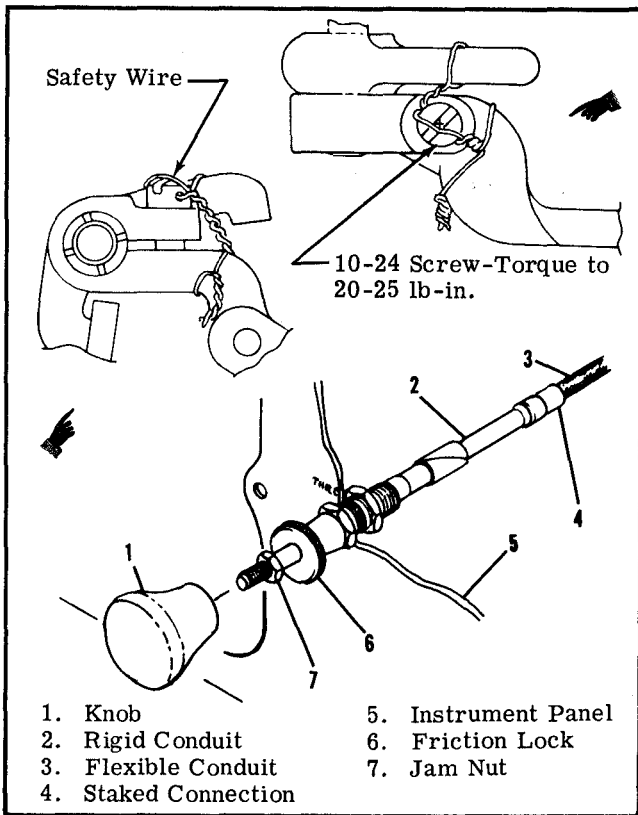

Figure 11-8. Throttle Control

NOTE

Some controls have intricate parts that will fall out and possibly be lost if the control is pulled from housing while the control is disconnected.

11-51. **RIGGING.** When adjusting any engine control, it is important to check that the control slides smoothly throughout its full range of travel, that it locks securely if equipped with a locking device, and the arm or lever which it operates moves through its full arc of travel.

CAUTION

Whenever engine controls are being disconnected, pay particular attention to the exact position, size, and number of attaching washers and spacers. Be sure to install attaching parts as noted when connecting controls.

11-52. **THROTTLE CONTROL.**

NOTE

Before rigging throttle control shown in figure 11-8, check that staked connection between rigid conduit and flexible conduit is secure. If any indication of looseness or breakage is apparent, install new throttle control before continuing rigging procedure.

- a. Pull throttle control out (idle position) and remove throttle control knob.
- b. Screw jam nut all the way down (clockwise) and install throttle knob. Screw knob securely against the jam nut. Do not back jam nut out. This will prevent bottoming and possible damage to the staked connection.
- c. Disconnect throttle control at the carburetor throttle arm, push throttle control in until jam nut contacts friction lock. While the friction lock is loose, then pull control out approximately 1/8 inch for cushion. Note position of larger washer at carburetor end of control. Install washer in same position when connecting control to arm.
- d. Tighten friction lock, being careful not to change position of the throttle.
- e. Move throttle arm on the carburetor to full open, adjust rod end at end of throttle control to fit, and connect to arm on carburetor.
- f. Release friction lock and check full travel of arm on carburetor. If further adjustment is required, make all adjustments at the carburetor end of control. **DO NOT** change jam nut setting.
- g. Tighten rod end locknuts at carburetor end of control. Be sure to maintain sufficient thread engagement between rod end and control.

NOTE

Refer to the inspection chart in Section 2 for inspection and/or replacement interval for the throttle control.

11-53. **MIXTURE CONTROL.**

- a. Push mixture control full in (RICH), unlock then pull it out approximately 1/8 inch for cushion.
- b. Loosen clamp securing the control housing to the engine.
- c. Shift the control housing in the clamp so that the mixture arm on the carburetor is in full open (RICH). Tighten clamp in this position.
- d. Unlock and pull mixture control full out. Check that mixture arm on carburetor is full closed (IDLE CUT-OFF).
- e. Check that bolt and nut at the mixture arm on the carburetor secures the control wire and that the bolt will swivel in the arm.
- f. Bend control wire tip 90 degrees to prevent it from being withdrawn if the attaching nut should become loose.
- g. When installing a new control assembly, it may be necessary to shorten the wire and/or control housing.
- h. The mixture arm on the carburetor must contact the stops in each direction, and the control should have approximately 1/8 inch cushion when pushed full in (RICH).

NOTE

Refer to the inspection chart in Section 2 for inspection and/or replacement interval for the mixture control.

11-54. CARBURETOR HEAT CONTROL.

- a. Loosen clamp securing the control to the bracket on the airbox.
- b. Push control full in, then pull it out approximately 1/8 inch from panel for cushion.
- c. Shift the control housing in its clamp so that the valve lever is full forward, with valve seating inside airbox. Tighten clamp in this position.
- d. Pull out on the control and check that the air valve inside the airbox seats in the opposite direction.
- e. Check that bolt and nut on the air throttle lever secures the control wire and that the bolt will swivel in the lever.

- f. Bend the wire tip 90 degrees to prevent it from becoming withdrawn if the attaching nut should become loose.

NOTE

Refer to the inspection chart in Section 2 for inspection and/or replacement interval for the carburetor heat control.

11-55. STARTING SYSTEM.

- 11-56. The automatically engaged starting system

This page intentionally left blank.

employs an electric starter motor mounted at the rear of the accessory housing. A starter solenoid is activated by the ignition key on the instrument panel. When the solenoid is activated, its contacts close and

electrical current energizes the starter motor. Initial rotation of the starter motor engages the starter through an overrunning clutch in the starter adapter.

11-57. TROUBLE SHOOTING.

TROUBLE	PROBABLE CAUSE	REMEDY
STARTER WILL NOT OPERATE.	Defective master switch or circuit.	Install new switch or wires.
	Defective starter switch or switch circuit.	Install new switch or wires.
	Defective starter motor.	Remove, repair or install new starter motor.
STARTER MOTOR RUNS, BUT DOES NOT TURN CRANK-SHAFT.	Defective overrunning clutch or drive.	Install new starter adapter.
	Starter motor shaft broken.	Install new starter motor.
STARTER MOTOR DRAGS.	Low battery.	Charge or install new battery.
	Starter switch or relay contacts burned or dirty.	Install serviceable unit.
	Defective starter motor power cable.	Install new cable.
	Loose or dirty connections.	Remove, clean and tighten all terminal connections.
	Defective starter motor.	Check starter motor brushes, brush spring tension, thrown solder on brush cover. Repair or install new starter motor.
	Dirty or worn commutator.	Clean and turn commutator.

11-58. REMOVAL AND INSTALLATION.

- a. Remove cowling as required for access.

CAUTION

When disconnecting or connecting the starter cable, do not permit starter terminal bolt to rotate. Rotation of the terminal bolt could break the conductor between terminal and field coils causing the starter motor to be inoperative.

- b. Disconnect starter power cable at starter. Insulate terminal on power cable to prevent accidental shorting.

- c. Remove three Palnuts and three hex head nuts attaching starter adapter to crankcase cover studs.

- d. Cut safety wire and remove two bolts threaded through crankcase into starter.

- e. Tap starter gently to loosen gasket and remove starter and adapter with a straight rearward movement.

- f. Clean any gasket which may be stuck to starter, starter adapter, or crankcase cover.

g. When installing starter, work a non-hardening gasket paste into both sides of a new gasket, and position starter and adapter assembly against crankcase pad.

h. Install three plain washers and hex head nuts on studs and install bolts through crankcase.

CAUTION

Tighten bolts and nuts evenly to prevent warping adapter cover.

i. Install new Palnuts on cover studs and lock wire on bolt heads.

j. Connect starter power cable to starter.

11-59. PRIMARY MAINTENANCE. The starting circuit should be inspected at regular intervals, the frequency of which should be determined by the amount of service and conditions under which the equipment is operated. Inspect the battery and wiring. Check battery for fully charged condition, proper electrolyte level with approved water and terminals for cleanliness. Inspect wiring to be sure that all connections are clean and tight and that the wiring insulation is sound. Check that the brushes slide freely in their holders and make full contact on the commutator. When brushes are worn to one-half of their original length, install new brushes (compare brushes with new brushes). Check the commutator for uneven wear, excessive glazing or evidence of excessive arcing. If the commutator is only slightly dirty, glazed, or discolored, it may be cleaned with a strip of No. 00 or No. 000 sandpaper. If the commutator is rough or worn, it should be turned in a lathe and the mica undercut. Inspect the armature shaft for rough bearing surfaces. New brushes should be properly seated when installing by wrapping a strip of No. 00 sandpaper around the commutator (with sanding side out) 1-1/4 to 1-1/2 times maximum. Drop brushes on sandpaper covered commutator and turn armature slowly in the direction of normal rotation. Clean sanding dust from motor after sanding operations.

11-60. EXHAUST SYSTEM. The exhaust system consists of a muffler for each bank of cylinders with an exhaust pipe from each cylinder to the muffler on that side of the engine. The muffler assemblies are enclosed in shrouds which captures ram air to be heated by the exhaust gases in the muffler. This heated air is used to heat the aircraft cabin and to furnish heated air for carburetor heat at the engine intake system. A tail pipe from each muffler routes exhaust gases overboard through the lower cowling.

11-61. REMOVAL.

a. Remove engine cowling as required for access.

b. Disconnect flexible ducts from shrouds on muffler assemblies.

c. Disconnect braces from muffler and tail pipe assemblies.

d. Remove nuts and washers securing the exhaust stack assemblies to the cylinders.

e. Remove exhaust stack assembly.

11-62. INSPECTION of the exhaust system shall be thorough because the cabin heating system uses air heated by the heat exchangers of the exhaust system. Since exhaust systems of this type are subject to burning, cracking, and general deterioration from alternate thermal stresses and vibration, inspection is very important and should be accomplished every 100-hours of operation. In addition, an inspection of the exhaust system shall be performed anytime exhaust fumes are detected in the cabin area.

a. Remove engine cowling, and loosen or remove shrouds so that ALL surfaces of the exhaust system can be visually inspected. Especially check areas adjacent to welds. Look for exhaust gas deposits in surrounding areas, indicating that exhaust gas is escaping through a crack or hole.

b. For a more thorough inspection, or if fumes have been detected in the cabin, the following inspection is recommended:

1. Remove exhaust pipe and mufflers.

2. Use rubber expansion plugs to seal openings.

3. Using a manometer or gage, apply approximately 1-1/2 psi (3 inches of mercury) air pressure while the muffler and each exhaust pipe is submerged in water. All leaks will appear as bubbles and can be readily detected.

4. It is recommended that any exhaust pipe or muffler found defective be replaced with a new part before the next flight.

c. Install exhaust system.

11-63. INSTALLATION. Reverse procedure outlined in paragraph 11-61 to install exhaust system. Be sure there is one new copper-asbestos gasket between each exhaust pipe and its mounting pad on the cylinder. Make sure clamps attaching mufflers to exhaust pipes are tight and all air ducts are installed.

11-64. EXTREME WEATHER MAINTENANCE.

11-65. COLD WEATHER. Cold weather starting is made easier with the installation of the engine primer system and ground service receptacle. The primer system is a manually operated type. Fuel is supplied by a line from the fuel strainer to the plunger type

primer. Operating the primer plunger in the cabin forces fuel to the engine. Fuel is delivered to the intake manifold above the carburetor, therefore, priming the intake manifold. Crushed or broken primer lines should be replaced with new parts. Primer lines should be properly clamped to prevent vibration and chafing. With the ground service receptacle installed, an external power source may be connected to assist in cold weather or low battery starting. Refer to paragraph 11-66 for use of the ground service receptacle.

The following may also be used to assist engine starting in extreme cold weather. After the last flight of the day, drain the engine oil into a clean container so the oil can be preheated. Cover the engine to prevent ice or snow from collecting inside the cowling. When preparing the aircraft for flight or engine run-up after these conditions have been followed, preheat the drained oil.

WARNING

Do not heat oil above 121°C (250°F). A flash fire may result. Before pulling the propeller through, ascertain that magneto switch is in OFF position to prevent the engine from firing.

After preheating the oil, gasoline may be mixed with the heated oil in a ratio of 1 part gasoline to 12 parts oil before pouring into the engine oil sump. If the free air temperature is below -29°C (-20°F), the engine compartment should be preheated with a ground heater. After the engine compartment has been preheated, inspect all engine drain and vent lines for presence of ice. After this procedure has been complied with, pull propeller through several revolutions by hand before starting the engine.

CAUTION

Due to the desludging effect of the diluted oil, engine operation should be observed closely during the initial warm-up of the engine. Engines that have a considerable amount of operational hours accumulated since their last dilution period may be seriously affected by the dilution process. This is caused by the diluted oil dislodging sludge and carbon deposits within the engine. This residue will collect in the oil sump and possibly clog the screened inlet to the oil pump. Small deposits may actually enter the oil pump and be trapped by the pressure oil filter screen. Partial or, in some cases, complete loss of engine lubrication may result from either condition. If these conditions are anticipated after oil dilution, the engine should be operated for several minutes at normal operating temperatures and then stopped and inspected for evidence of sludge and carbon deposits in the oil sump and oil filter screen. Future occurrence of this condition can be prevented by diluting the oil prior to each oil change. This will prevent the build-up accumulation of the sludge and carbon deposits within the engine.

11-66. GROUND SERVICE RECEPTACLE. With the ground service receptacle installed, the use of an external power source is recommended for cold weather and low battery starting and lengthy maintenance work on the aircraft electrical systems. The battery and external power circuits have been designed to completely eliminate the need to "jumper" across the battery contactors to close it. A special fused circuit in the external power system supplies the needed "jumper" across the contacts so that with a "dead" battery and an external power source applied, turning the master switch ON will close the battery contactor.

CAUTION

Be certain that the polarity of any external power source is correct (positive to positive and negative to negative). A polarity reversal will result in immediate damage to the electrical and electronic circuits of the aircraft.

11-67. HOT WEATHER. Engine mis-starts characterized by weak, intermittent explosions followed by puffs of black smoke from the exhaust are caused by over-priming or flooding. This situation is more apt to develop in hot weather or when the engine is hot. If it occurs, repeat the starting routine with the throttle approximately one-half OPEN, and the mixture control in IDLE CUT-OFF. As the engine fires, move the mixture control to full RICH and decrease the throttle setting to desired idling speed.

Engine mis-starts characterized by sufficient power to disengage the starter but dying after three to five revolutions are the result of an excessively lean mixture after the start. This can occur either in warm or cold temperatures. Repeat the starting routine with additional priming.

CAUTION

Never operate the starting motor more than 12 seconds at a time. Allow starter motor to cool between cranking periods to avoid overheating. Longer cranking periods will shorten the life of the starter.

11-68. DUSTY CONDITIONS. Dust inducted into the intake system of the engine is probably the greatest single cause of early engine wear. When operating under high dust conditions, the induction air filter should be serviced daily as outlined in paragraph 2-17.

11-69. SEACOAST AND HUMID AREAS. In salt water areas, special care should be taken to keep the engine and accessories clean to prevent oxidation. In humid areas, fuel and oil should be checked frequently and drained of condensed moisture.

11-70. HAND CRANKING. A normal hand-cranking procedure may be used to start the engine.

This page intentionally left blank.

SECTION 12

FUEL SYSTEM

TABLE OF CONTENTS	Page		
FUEL SYSTEM	12-1	Checking.	12-7
Description	12-1	Fuel Shut-Off Valve	12-7
Precautions	12-1	Description	12-7
Trouble Shooting	12-2	Removal and Installation	12-7
Fuel Tanks.	12-7	Fuel Strainer.	12-7
Description	12-7	Description	12-7
Removal and Installation	12-7	Disassembly and Assembly	12-7
Fuel Quantity Transmitters	12-7	Priming System	12-8
Fuel Vents.	12-7	Description	12-8
Description	12-7	Removal and Installation	12-8

12-1. FUEL SYSTEM.

12-2. DESCRIPTION. Fuel is gravity-fed from the metal wing tanks, through a shut-off valve and a fuel strainer, to the carburetor. Positive ventilation is provided by a vent line and check valve assembly located in the left wing tank and a crossover line connecting the two tanks together. The vent line from the check valve assembly extends overboard through the lower wing skin adjacent to the left wing strut. A fuel line drain is located between the shut-off valve and the strainer.

12-3. PRECAUTIONS.

NOTE

There are certain general precautions and rules concerning the fuel system which should be observed when performing the operations and procedures in this section. These are as follows:

a. During all fueling, defueling, tank purging, and tank repairing or disassembly, ground the aircraft

to a suitable ground stake.

b. Residual fuel draining from lines and hose constitutes a fire hazard. Use caution to prevent the accumulation of fuel when lines or hose are disconnected.

c. Cap open lines and cover connections to prevent thread damage and the entrance of foreign matter.

NOTE

Throughout the aircraft fuel system, from the tanks to the carburetor, use NS-40 (RAS-4) (Snap-On-Tools Corp., Kenosha, Wisconsin), MIL-T-5544 (Thread Compound Antiseize, Graphite Petrolatum), USP Petrolatum or engine oil as a thread lubricator or to seal a leaking connection. Apply sparingly to male threads only, omitting the first two threads, exercising extreme caution to avoid "stringing" sealer across the end of the fitting. Always ensure that a compound, the residue from a previously used compound, or any other foreign material cannot enter the system.

12-4. TROUBLE SHOOTING.

TROUBLE	PROBABLE CAUSE	REMEDY
NO FUEL TO CARBURETOR.	Fuel shut-off valve not turned on.	Turn valve on. (Safety in ON position.)
	Fuel tanks empty.	Service with proper grade and amount of fuel.
	Fuel line disconnected or broken.	Connect or repair fuel lines.
	Inlet elbow or inlet screen in carburetor plugged.	Clean and/or replace.
	Fuel tank outlet strainers plugged.	Remove and clean strainers and flush out fuel tanks.
	Defective fuel shut-off valve.	Replace shut-off valve.
	Plugged fuel strainer.	Remove and clean strainer and screen.
	Fuel line plugged.	Clean out or replace fuel line.
FUEL STARVATION AFTER STARTING.	Partial fuel flow from the preceding causes.	Use the preceding remedies.
	Plugged fuel vent.	See paragraph 12-11.
	Water in fuel.	Drain fuel tank sumps, fuel lines and fuel strainer.
NO FUEL QUANTITY INDICATION.	Fuel tanks empty.	Service with proper grade and amount of fuel.
	Blown fuse.	Replace blown fuse.
	Loose connections or open circuit.	Tighten connections; repair or replace wiring. Refer to Section 20.
	Defective fuel quantity indicator or transmitter.	Refer to Section 15.
PRESSURIZED FUEL TANK	Plugged bleed hole in fuel vent.	Check per paragraph 12-11.

SHOP NOTES:

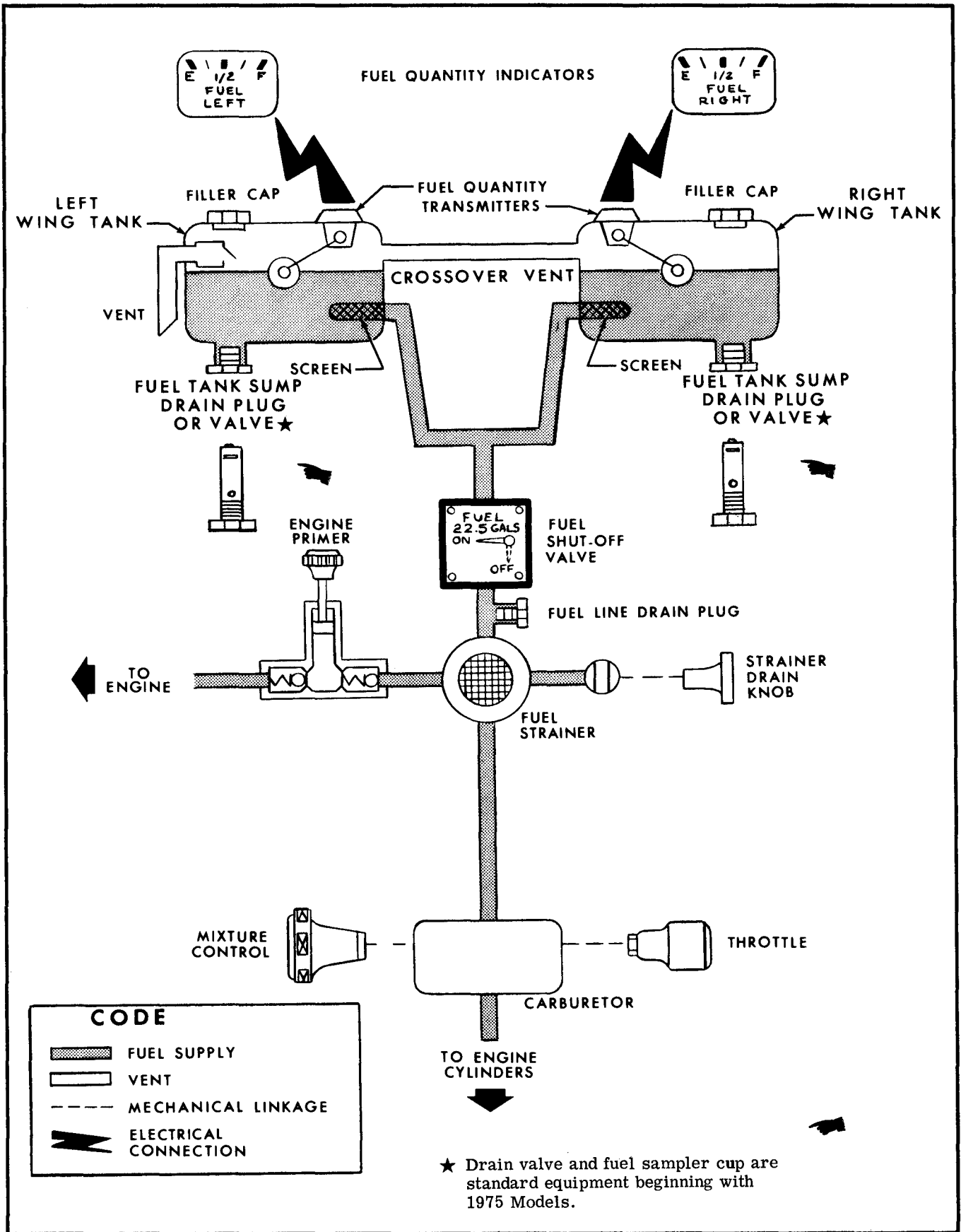

Figure 12-1. Fuel System Schematic

Thru 15073658, A1500342, F15000863 and FA1500166, handle (7) is safetied to the lower mounting bolt. Beginning with 15073659, A1500343, F15000864 and FA1500167, handle (7) is safetied to a bolt, located in the floorboard. The handle is safetied in the "ON" position with .018" dia. mild steel safety wire (tag wire), which will break easily if handle must be turned "OFF" in an emergency.

All fuel hoses should be replaced at engine overhaul or after 5 years, whichever comes first.

Shut-off valve (9) should be replaced and not repaired.

A PRIOR TO 150-70840 & F150-0620

B BEGINNING WITH 150-70840 & F150-0620

BEGINNING WITH 1973 MODELS

THRU 1972 MODELS

★ 90° ELBOW THRU 15070839

NIPPLE 15070840 THRU 15072003

45° ELBOW BEGINNING WITH 15072004

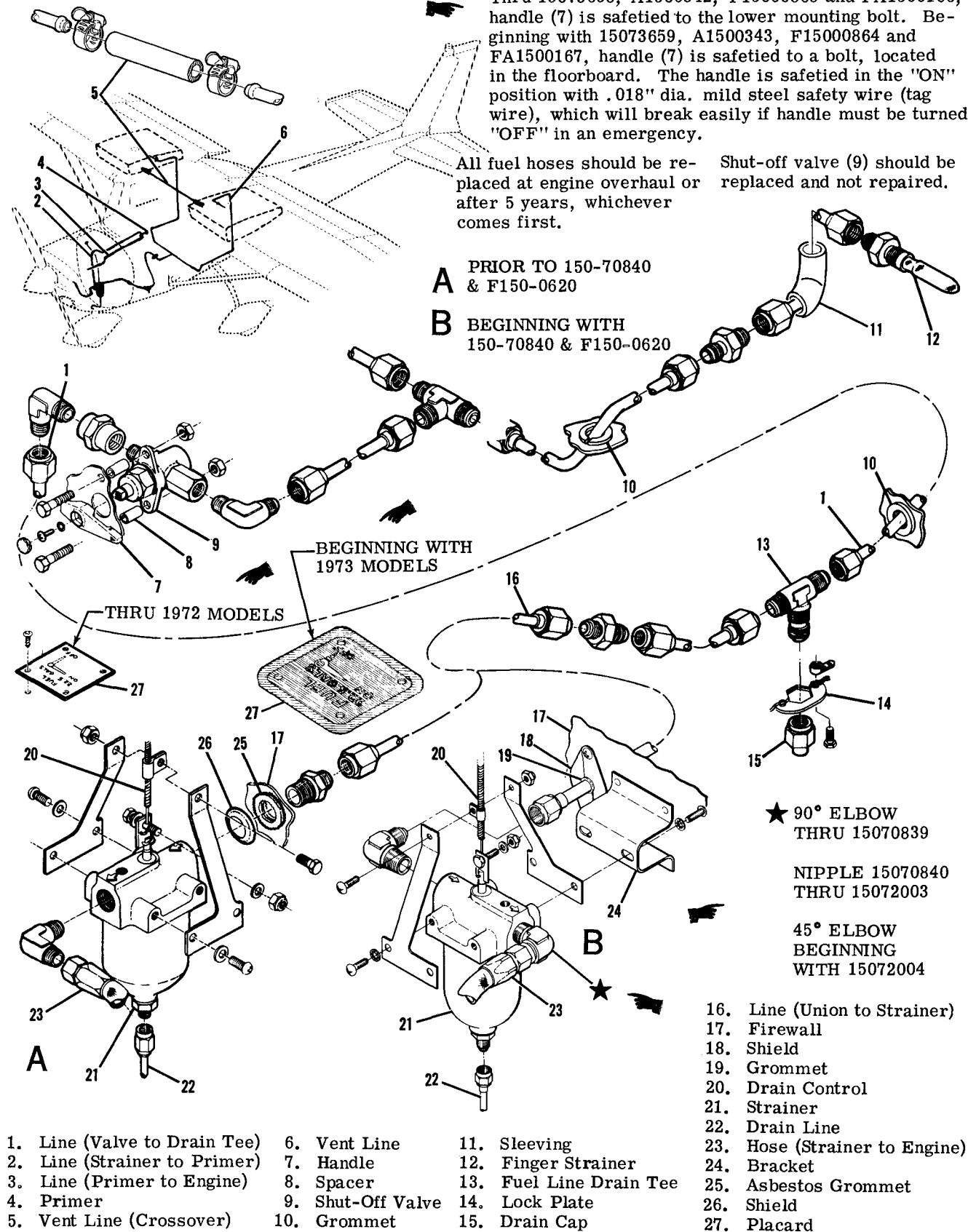

Figure 12-2. Fuel System

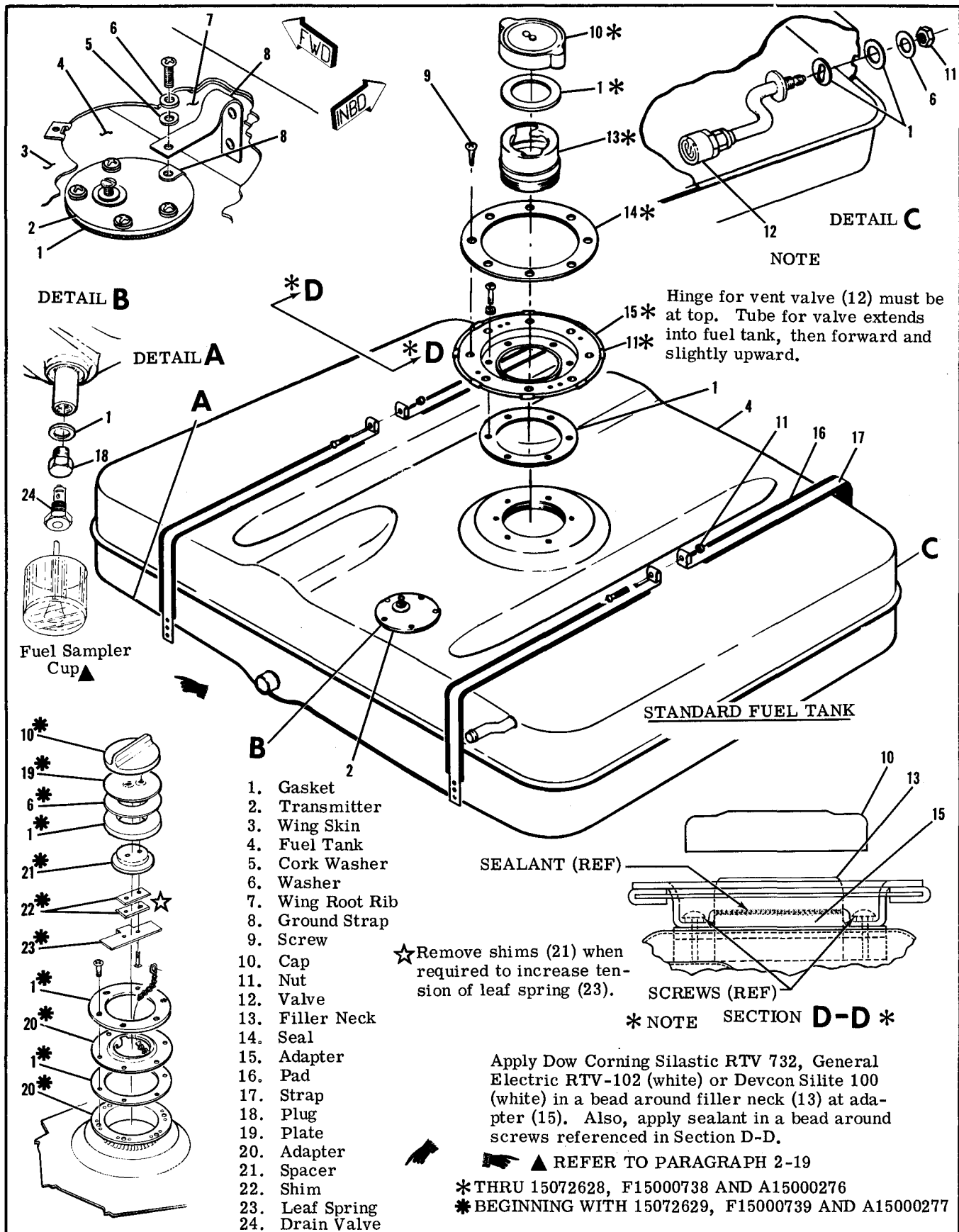

Figure 12-3. Fuel Tank (Sheet 1 of 2)

***NOTE**

Apply Dow Corning Silastic RTV 732, General Electric RTV-102 (white) or Devcon Silite 100 (white) in a bead around filler neck (9) at adapter (6). Also, apply sealant in a bead around screws referenced in Section C-C.

NOTE

For ground strap installation, see sheet 1.

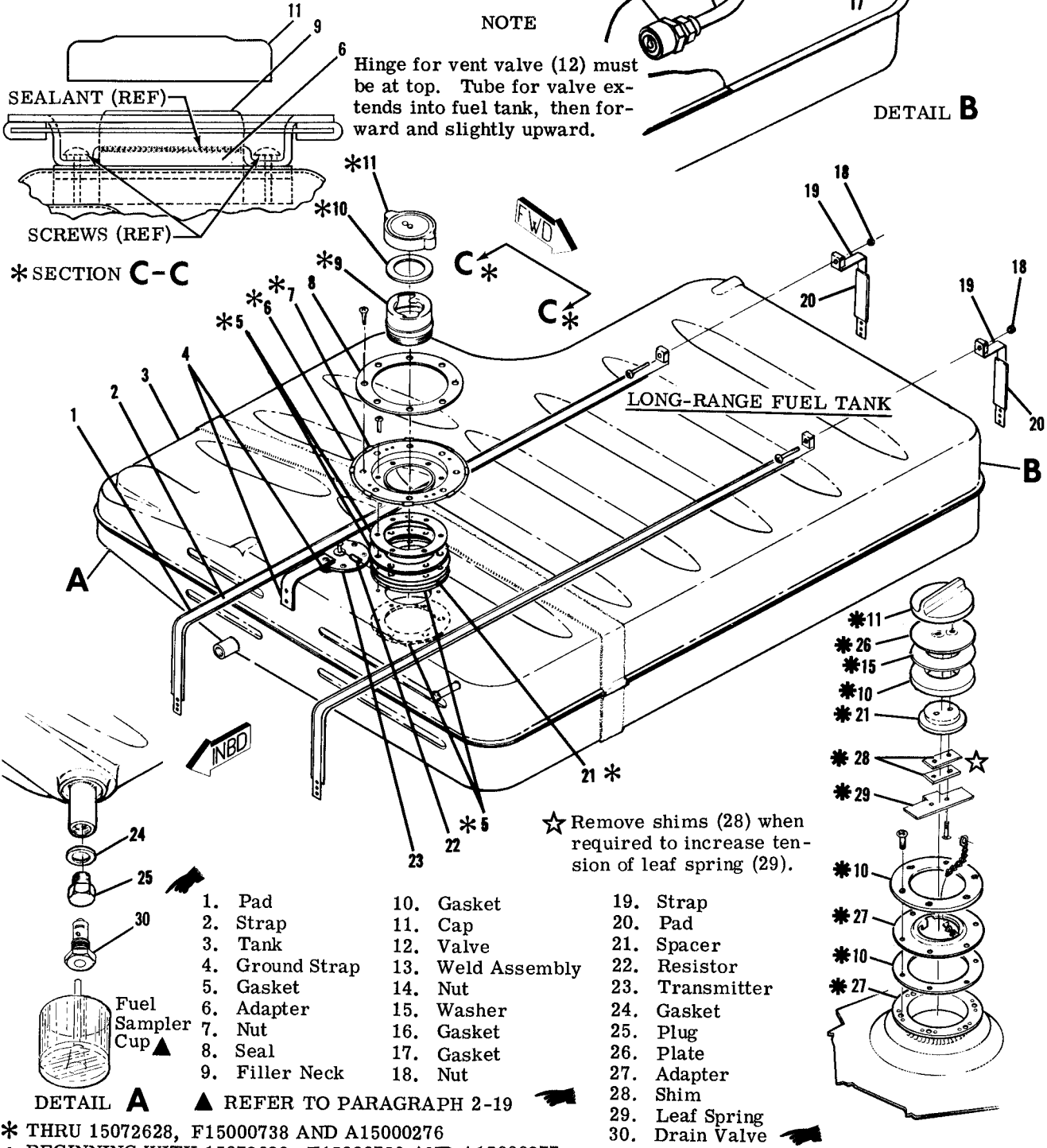

Figure 12-3. Fuel Tank (Sheet 2 of 2)

12-5. FUEL TANKS.

12-6. DESCRIPTION. A rigid metal tank is installed in the inboard panel of each wing. Sump drain plugs or valves, one in each tank, are provided for draining trapped water and sediment.

12-7. REMOVAL AND INSTALLATION.

- a. Remove sump drain plug or valve and drain fuel from applicable tank. (Observe precautions outlined in paragraph 12-3.)
- b. Remove fuel tank cover by removing attaching screws.
- c. Remove wing root fairings.
- d. Disconnect and plug or cap all fuel and vent lines from tank. Remove fittings as necessary for clearance when removing tank.
- e. Disconnect electrical lead and ground strap from fuel quantity transmitter.
- f. Disconnect straps securing fuel tank and remove tank. Use care to avoid damage to protruding fittings and hose connections when removing the tank.
- g. To install tank, reverse the preceding steps. Be sure grounding is secure in accordance with figure 12-3.

12-8. FUEL QUANTITY TRANSMITTERS. Fuel quantity transmitters are installed in the top of fuel tanks. A complete description, along with procedures for removal, installation and adjustment are contained in Section 15.

12-9. FUEL VENTS.

12-10. DESCRIPTION. A vent line is installed in the outboard end of the left fuel tank and extends overboard down through the lower wing skin. The inboard end of the vent line extends into the fuel tank, then forward and slightly upward. A vent valve is installed on the inboard end of the vent line inside the fuel tank, and a crossover vent line connects the two tanks for positive ventilation.

12-11. CHECKING. Field experience has demonstrated that the fuel vent can become plugged, with possible fuel starvation of the engine or collapse of the fuel tanks. Also, the bleed hole in the vent valve assembly could possibly become plugged, allowing pressure from expanding fuel to pressurize the tanks. The following procedure may be used to check the vent and bleed hole in the valve assembly.

- a. Attach a rubber tube to the end of vent line beneath the wing.
- b. Blow into tube to slightly pressurize the tanks. If air can be blown into tanks, vent line is open.
- c. After tank is slightly pressurized, insert end of rubber tube into a container of water and watch for a continuous stream of bubbles, which indicates the bleed hole in valve assembly is open and relieving pressure.
- d. After completion of step "c", blow into tube again to slightly pressurize the tank, and loosen, but do not remove filler cap on opposite wing to check tank crossover line. If pressure escapes from filler cap, crossover line is open.

NOTE

Remember that a plugged vent line or bleed hole can cause either fuel starvation and collapsing of fuel tanks or the pressurization of tanks by fuel expansion.

- e. Any fuel vent found plugged or restricted must be corrected prior to returning aircraft to service.

NOTE

The fuel vent line protruding beneath the wing near the wing strut must be correctly aligned to avoid possible icing of the vent tube. Dimensions are shown in figure 12-4.

12-12. FUEL SHUT-OFF VALVE. (See figure 12-2.)

12-13. DESCRIPTION. The fuel shut-off valve is a two-position ON-OFF valve, located in the floor area between the pilot and copilot positions. Thru 1972 Models, the handle is safetied to the lower mounting bolt. Beginning with 1973 Models, the handle is safetied to a bolt, located in the floorboard. The handle is safetied in the "ON" position with .018" diameter mild steel wire (tag wire), which will break easily if the handle must be turned OFF in an emergency. It is recommended that the valve be replaced and not repaired.

12-14. REMOVAL AND INSTALLATION.

- a. Completely drain all fuel from wing tanks, fuel lines, strainer, and shut-off valve. (Observe the precautions in paragraph 12-3.)
- b. Remove shut-off valve handle.
- c. Remove copilot's seat and access plate under seat.
- d. Disconnect and cap all fuel lines at shut-off valve.
- e. Remove bolts attaching shut-off valve and remove valve.
- f. Reverse the preceding steps for installation. Safety wire valve handle in "ON" position.

12-15. FUEL STRAINER. (See figure 12-5.)

12-16. DESCRIPTION. The fuel strainer is mounted at the firewall in the lower engine compartment. The strainer is equipped with a quick-drain valve which provides a means of draining trapped water and sediment from the fuel system. The quick-drain control is located adjacent to the oil dipstick and is accessible through the oil dipstick door.

NOTE

The fuel strainer can be disassembled, cleaned and reassembled without removing the assembly from the aircraft. (Refer to paragraph 12-20.)

12-17. DISASSEMBLY AND ASSEMBLY. (See figure 12-5.)

- a. Remove drain tube, safety wire, nut and washer at bottom of filter bowl, and remove bowl.
- b. Carefully unscrew standpipe and remove.
- c. Remove filter screen and gasket. Wash filter screen and bowl with solvent (Federal Specification

NOTE

The fuel vent line protruding beneath the wing near the wing strut must be correctly aligned to avoid possible icing of the vent tube.

A 150 AND F150

B A150 AND FA150

- 1. Wing Strut
- 2. Wing Skin
- 3. Bracket
- 4. Clamp
- 5. Grommet
- 6. Vent Tube

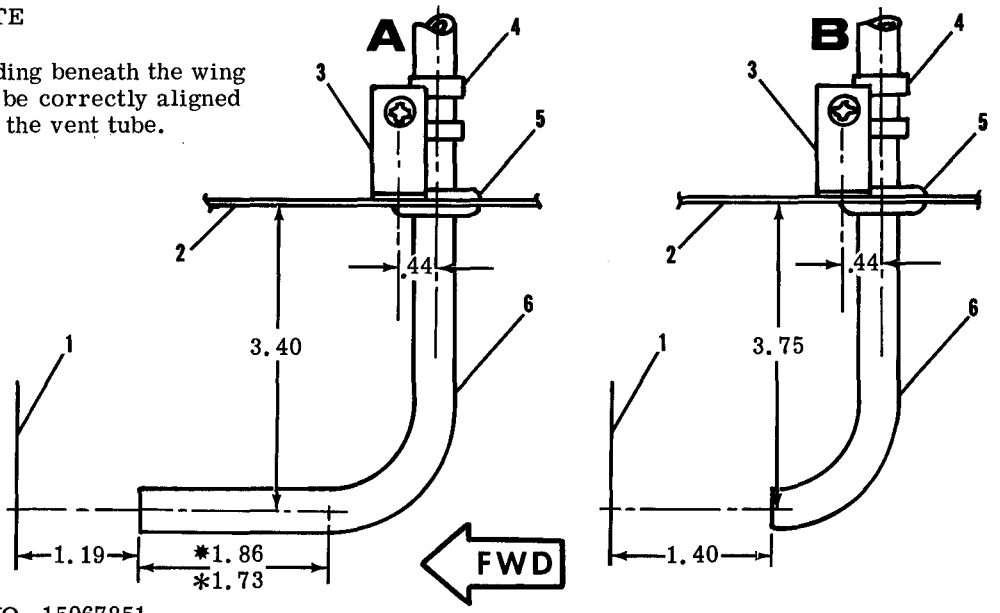

* PRIOR TO SERIAL NO. 15067851
PRIOR TO SERIAL NO. F150-0360

* SERIAL NO. 15067851 AND ALL SERVICE PARTS
SERIAL NO. F150-0360 AND ALL SERVICE PARTS

VENT LINE MUST BE PARALLEL TO WING CHORD LINE. TOLERANCE UP 5°, DOWN 0°.

Figure 12-4. Fuel Vent Location

P-S-661, or equivalent) and dry with compressed air.

d. Using a new gasket between filter screen and top assembly, install screen and standpipe. Tighten standpipe only finger tight.

e. Using all new O-rings, install bowl. Note that step-washer at bottom of bowl is installed so that step seats against O-ring.

f. Turn shut-off valve to "ON" position, check for leaks and proper operation.

g. Torque bottom nut (15) to 25-30 lb-in., and safety wire to top assembly of strainer. Wire must have right-hand wrap, at least 45 degrees.

h. Connect drain tube.

12-18. PRIMING SYSTEM. (See figure 12-2.)

12-19. DESCRIPTION. The priming system is comprised of a manually-operated primer located on the instrument panel, and a line from the primer to the

intake manifold. Operation of the plunger forces fuel directly into the engine intake manifold.

12-20. REMOVAL AND INSTALLATION.

- a. Disconnect and cap all lines at primer.
- b. Unscrew knurled nut and remove plunger from pump body.
- c. Remove pump body from instrument panel.

NOTE

Visually inspect primer lines for crushed, kinked, or broken condition. Ensure proper clamping to prevent fatigue due to vibration and chafing.

d. Prior to installing a primer, check for proper pumping action and positive fuel shut-off in the locked position.

e. Reverse preceding steps for installation.

SHOP NOTES:

SECTION 13

PROPELLER

TABLE OF CONTENTS	Page
PROPELLER	13-1
Description	13-1
Repair	13-1
Removal (Thru 1970 Models)	13-1

Installation (Thru 1970 Models)	13-1
Removal (Beginning with 1971 Models)	13-1
Installation (Beginning with 1971 Models)	13-3

13-1. PROPELLER.

13-2. DESCRIPTION. An all-metal, fixed-pitch propeller, equipped with a spinner, is used on the aircraft. Several types of spinner installations are used, depending on the type and model-year of the aircraft. Refer to figures 13-1 and 13-2 for the different installations of the propellers and spinners.

13-3. REPAIR. Repair of a metal propeller first involves evaluating the damage and determining whether the repair is to be a major or minor one. Federal Aviation Regulations, Part 43 (FAR 43), and Federal Aviation Agency Advisory Circular No. 43.13 (FAA AC No. 43.13), define major and minor repairs, alterations and who may accomplish them. When making repairs or alterations to a propeller, FAR 43, FAA AC No. 43.13 and the propeller manufacturer's instructions must be observed. The propeller manufacturer's Service Manual may be obtained from the Cessna Service Parts Center.

13-4. REMOVAL. (THRU 1970 MODELS.) (Refer to figure 13-1.)

WARNING

Be sure magneto switch is in OFF position before turning propeller.

- a. Remove spinner.

NOTE

The small spinner mounting bracket (3) is attached with two of the propeller mounting bolts (6). The early large spinner (9) is attached to two spinner bulkheads. These bulkheads are secured by the propeller mounting bolts (6) and will be freed by removal of the bolts as the propeller is removed. The later large spinner (10) is attached to the rear bulkhead with a forward supporting bulkhead. Note the number of shims (11) behind the forward bulkhead upon removal and retain these shims. The rear bulkhead is secured by the propeller mounting bolts (6) and is removed as the propeller is removed. The later large spinner, bulkheads and attaching parts are used as spare parts for the early large spinner.

- b. Remove safety wire from mounting bolt heads (6).
- c. Remove bolts and pull propeller forward to remove. Use care to avoid damage to bulkheads as propeller is removed.

13-5. INSTALLATION. (THRU 1970 MODELS.) (Refer to figure 13-1.)

- a. Clean mating surfaces of propeller, crankshaft flange and spinner bulkheads.

WARNING

Be sure magneto switch is in OFF position before turning crankshaft.

- b. Locate top center of number one piston on its compression stroke. Align the top center mark on the crankshaft flange with parting surface of the crankcase below the crankshaft.
 - c. With propeller blades in vertical position, rotate blades 30 degrees clockwise looking aft.
 - d. Install propeller and spinner bulkheads. The spinner bulkheads must be positioned so propeller blades will emerge from the spinner with ample clearance.
 - e. Tighten the mounting bolts (6) evenly to a torque value of 300-320 lb-in (thru 1969 models) and 300-360 lb-in (beginning with 1970 models).
 - f. Safety wire propeller mounting bolts (6). Do not allow safety wire to cross the top of bolt head as this would interfere with the installation of forward spinner bulkhead and shims.
 - g. Install spinner. When installing the later type spinner and bulkheads, add shims as required (maximum of 4) behind forward bulkhead to provide a snug fit between bulkhead and spinner when the rear bulkhead attachment holes are aligned.
- 13-6. REMOVAL. (Beginning with 1971 Models) (Refer to figure 13-2.)
- a. Remove spinner (1).
 - b. On aircraft serials 15072004 thru 15075781, A1500227 thru A15000523, F15000659 thru F15001143 and FA15000082 and on, proceed as follows:
 1. Remove forward bulkhead (3*). Retain any shims (4*) between bulkhead and propeller.

WARNING

Be sure magneto switch is in OFF position before turning propeller.

- 2. Remove safety wire from mounting bolt heads (10*).

AIRCRAFT SERIALS 15069309 THRU 15072003
AND F15000390 THRU F15000658

TORQUE PROPELLER MOUNTING BOLTS TO
300-320 LB-IN THRU AIRCRAFT SERIALS
15071128 AND F15000529
TORQUE PROPELLER MOUNTING BOLTS TO
300-360 LB-IN BEGINNING WITH AIRCRAFT
SERIALS 15071129, F15000530, A15000001
AND FA15000001

NOTE

This installation obsolete and no longer
available. Replaced by the installation
shown below. Refer to Cessna Service
Letters SE70-1 and SE71-28.

AIRCRAFT SERIALS 15069309 THRU 15071710,
A15000001 THRU A15000149, F15000390 THRU
F15000595 AND FA15000001 THRU FA15000026

INSTALL PROPELLER TO TRAIL TOP DEAD
CENTER 30 DEGREES.

CRANKSHAFT (REF)

AIRCRAFT SERIALS 15071711 THRU 15072003,
A15000150 THRU A15000226, F15000596 THRU
F15000658 AND FA15000027 THRU FA15000081

NOTE

Use spacers (11) as required to obtain a
mismatch of one half hole between spinner
and rear bulkhead before installing screws (1).

- | | |
|-----------------------|-------------------------------|
| 1. Screw | 7. Spinner Bulkhead (Rear) |
| 2. Spinner (Standard) | 8. Spinner Bulkhead (Forward) |
| 3. Bracket | 9. Spinner (Early Type) |
| 4. Propeller | 10. Spinner (Later Type) |
| 5. Washer | 11. Shim |
| 6. Bolt | |

Figure 13-1. Propeller and Spinner Installation (Sheet 1 of 2)

* AIRCRAFT SERIALS 15072004 THRU 15075781, A15000227 THRU A1500523, F15000659 THRU F15001143 AND FA15000082 AND ON.

* AIRCRAFT SERIALS 15074851 & ON, A1500430 & ON, F15001014 & ON, AND FA15000212 & ON

AIRCRAFT SERIALS 15075782 AND ON, A1500524 AND ON AND F15001144 AND ON

* STANDARD FOR AIRCRAFT SERIALS 15074851 & ON, A1500430 & ON, F15001014 & ON, AND FA1500212 & ON

1. Spinner
2. Screw
- *3. Forward Spinner Bulkhead (ABS)
- #3A. Forward Spinner Bulkhead (Aluminum)
- *4. Spacer
5. Propeller
6. Rear Spinner Bulkhead
7. Dowel Pin
8. Spacer
9. Washer
10. Bolt

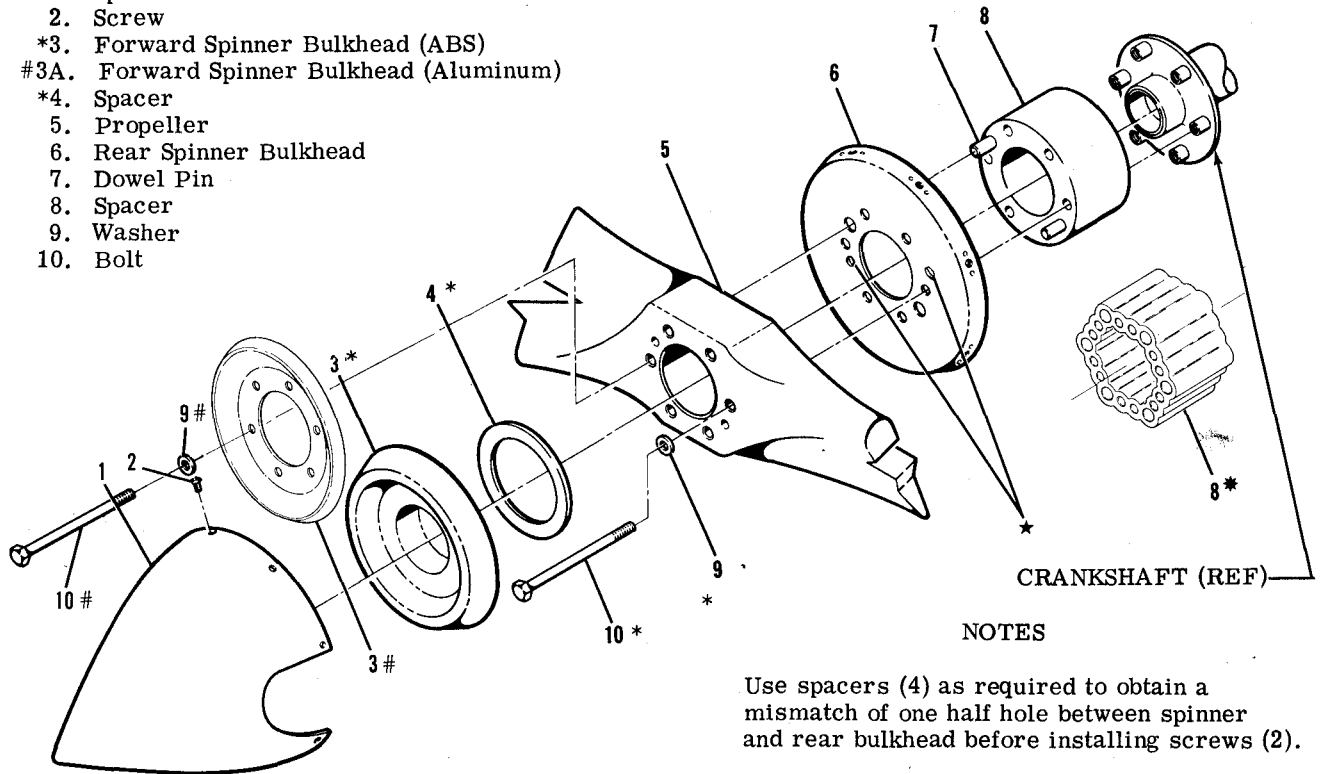

NOTES

Use spacers (4) as required to obtain a mismatch of one half hole between spinner and rear bulkhead before installing screws (2).

INSTALL PROPELLER TO TRAIL TOP DEAD CENTER 30 DEGREES. TORQUE PROPELLER MOUNTING BOLTS TO 300-360 LB-IN.

Figure 13-2. Propeller and Spinner Installation

3. Remove bolts and washers and pull propeller forward to remove.

WARNING

Be sure magneto switch is in OFF position before turning propeller.

NOTE

The aft spinner bulkhead (6) is installed between propeller (5) and spacer (8), and is removed as the propeller is removed.

NOTE

The aft spinner bulkhead (6) is installed between propeller (5) and spacer (8), and is removed as the propeller is removed.

4. Using a punch through holes in forward face of propeller, drive 2 dowel pins (7) aft to separate propeller and spacer, freeing the aft spinner bulkhead.

3. Using a punch through the holes in forward face of propeller, drive two dowel pins (7) aft to separate propeller and spacer, freeing aft spinner bulkhead.

c. Beginning with aircraft serials 15075782, A1500525 and F15001144, proceed as follows:

13-7. INSTALLATION. (Beginning with 1971 Models.) (Refer to figure 13-2.)

1. Remove safety wire from mounting bolt heads (10#).
2. Remove bolts and washers and remove forward bulkhead (10#).

a. Clean mating surfaces of propeller, crankshaft

flange, spacer and spinner bulkhead.

b. Position aft spinner bulkhead between propeller and spacer, and drive dowel pins into position to attach propeller, spacer and spinner bulkhead. Bulkhead must be positioned so that propeller blades emerge with ample clearance.

NOTE

Be sure magneto switch is in OFF position before turning crankshaft.

c. Locate top center of number one piston on its compression stroke. Align the top center mark on the crankshaft flange with parting surface of the crankcase below the crankshaft.

d. With propeller blades in vertical position, rotate blades 30 degrees clockwise (looking aft).

e. On aircraft serials 15072004 thru 15075781, A15000227 thru A15000523, F15000659 thru F15001143 and FA15000082 and on proceed as follows:

1. Install propeller on crankshaft flange and tighten bolts evenly and torque to 300-360 lb-in.

2. Safety wire propeller mounting bolts (10). Do not allow safety wire to cross the top of bolt heads as this would interfere with the installation of forward spinner bulkhead and shims.

3. Install forward bulkhead and spinner. Add shims as required (maximum of 4) behind forward bulkhead to provide a snug fit between bulkhead and spinner when the rear bulkhead attachment holes are aligned.

f. Beginning with aircraft serials 15075782, A1500524 and F15001144, proceed as follows:

1. Install propeller on crankshaft flange.

2. Install forward spinner bulkhead, tighten bolts evenly and torque to 300-360 lb-in.

3. Safety wire propeller mounting bolts. Safety wire must be installed around bolt heads and not over bolt heads.

4. Install spinner.

SHOP NOTES:

SECTION 14

UTILITY SYSTEMS

TABLE OF CONTENTS	Page
UTILITY SYSTEMS	14-1
Heating System	14-1
Description	14-1
Operation	14-1
Trouble Shooting	14-1
Removal, Installation and Repair	14-1
Defroster System	14-3
Description	14-3

Operation	14-3
Trouble Shooting	14-3
Removal, Installation and Repair	14-3
Ventilating System	14-3
Description	14-3
Operation	14-3
Trouble Shooting	14-3
Removal, Installation and Repair	14-3

14-1. UTILITY SYSTEMS.

14-2. HEATING SYSTEM.

14-3. DESCRIPTION. The heating system is comprised of the heat exchange section of the exhaust muffler, a shut-off valve, mounted on the right forward side of the firewall, a push-pull control on the instrument panel, outlets, and flexible ducting connecting the system.

14-4. OPERATION. Ram air is ducted through an engine baffle inlet and heat exchange section of the exhaust muffler, to the shut-off valve at the firewall. The heated air flows from the shut-off valve into a duct across the aft side of the firewall, where it is distributed into the cabin. The shut-off valve operated by a push-pull control marked "CABIN HEAT," located on the instrument panel, regulates the volume of heated air entering the system. Pulling the control full out supplies maximum flow, and pushing control in gradually decreases flow, shutting off flow completely when the control is pushed full in.

14-5. TROUBLE SHOOTING. Most of the operational troubles in the heating, defrosting, and ventilating systems are caused by sticking or binding air valves and their controls, damaged air ducting, or defects in the exhaust muffler. In most cases, valves or controls can be freed by proper lubrication. Dam-

aged or broken parts must be repaired or replaced. When checking controls, ensure valves respond freely to control movement, that they move in the correct direction, and that they move through their full range of travel and seal properly. Check that hose are properly secured, and replace hose that are burned, frayed or crushed. If fumes are detected in the cabin, a thorough inspection of the exhaust system should be accomplished. Refer to applicable paragraph in Section 11 for this inspection. Since any holes or cracks may permit exhaust fumes to enter the cabin, replacement of defective parts is imperative because fumes constitute an extreme danger. Seal any gaps in shut-off valves at the firewall with Pro-Seal #700 (Coast Pro-Seal Co., Los Angeles, California) compound, or equivalent compound.

14-6. REMOVAL, INSTALLATION AND REPAIR. Figure 14-1 illustrates the heating, defrosting, and ventilating systems, and may be used as a guide during removal, installation and repair of heating system components. Burned, frayed, or crushed hose must be replaced with new hose, cut to length and installed in the original routing. Trim hose winding shorter than the hose to allow clamps to be fitted. Defective air valves must be repaired or replaced. Check for proper operation of valves and their controls after repair or replacement.

* THRU 15072825, F15000738, A15000292 AND FA15000161
 * BEGINNING WITH 15072826, F15000739, A15000293 AND FA15000162
 (REFER TO SHEET 2)

NOTE

When the optional winterization kit is installed, heated air is supplied by both the left and right exhaust mufflers.

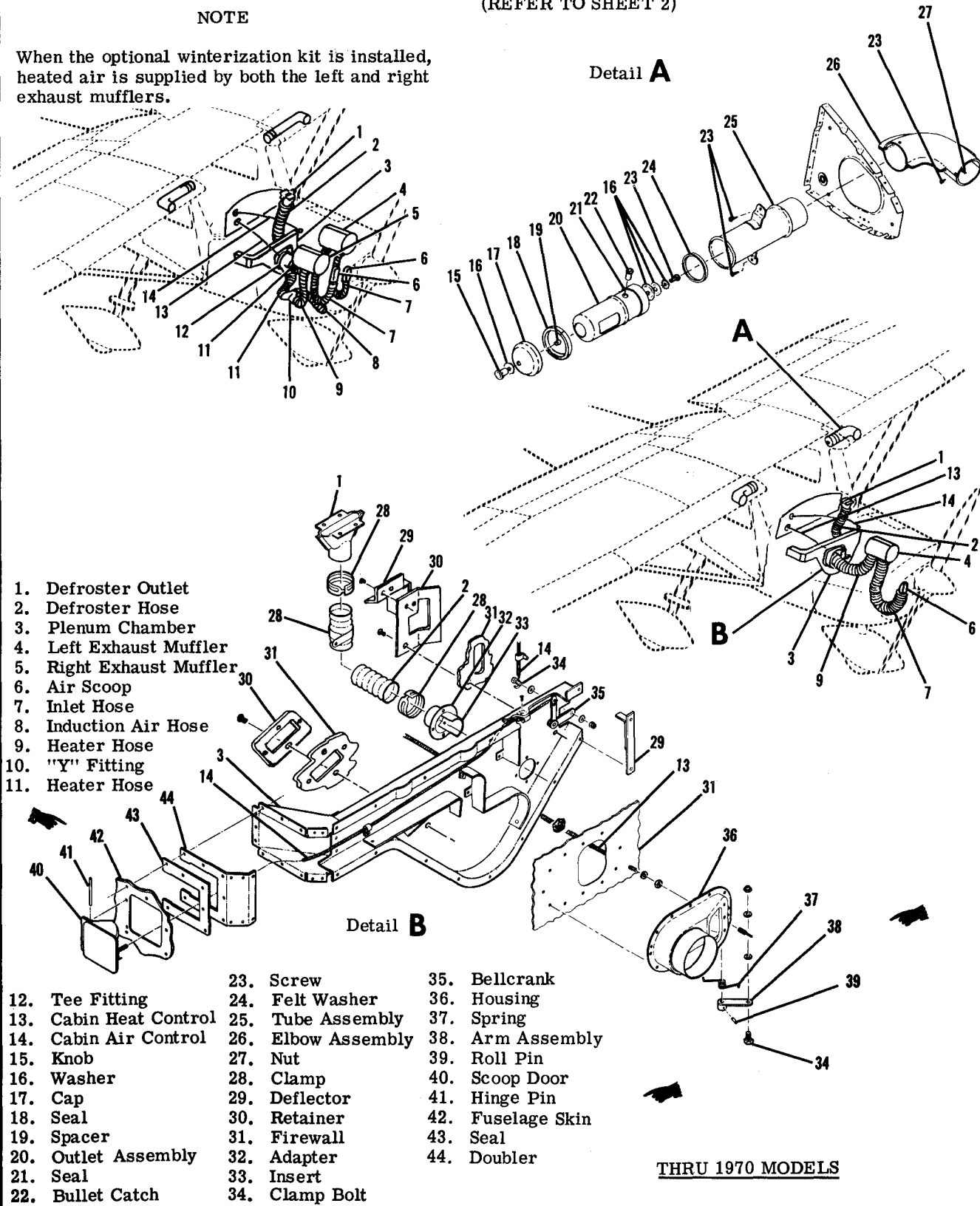

- 1. Defroster Outlet
- 2. Defroster Hose
- 3. Plenum Chamber
- 4. Left Exhaust Muffler
- 5. Right Exhaust Muffler
- 6. Air Scoop
- 7. Inlet Hose
- 8. Induction Air Hose
- 9. Heater Hose
- 10. "Y" Fitting
- 11. Heater Hose

- 12. Tee Fitting
- 13. Cabin Heat Control
- 14. Cabin Air Control
- 15. Knob
- 16. Washer
- 17. Cap
- 18. Seal
- 19. Spacer
- 20. Outlet Assembly
- 21. Seal
- 22. Bullet Catch

- 23. Screw
- 24. Felt Washer
- 25. Tube Assembly
- 26. Elbow Assembly
- 27. Nut
- 28. Clamp
- 29. Deflector
- 30. Retainer
- 31. Firewall
- 32. Adapter
- 33. Insert
- 34. Clamp Bolt

- 35. Bellcrank
- 36. Housing
- 37. Spring
- 38. Arm Assembly
- 39. Roll Pin
- 40. Scoop Door
- 41. Hinge Pin
- 42. Fuselage Skin
- 43. Seal
- 44. Doubler

THRU 1970 MODELS

Figure 14-1. Heating, Defrosting, and Ventilating Systems (Sheet 1 of 2)

- | | |
|--------------------------|--------------------------|
| 1. Knob | 22. Distributor Assembly |
| 2. Washer | 23. Clamp |
| 3. Cap | 24. Adapter |
| 4. Seal | 25. Insert |
| 5. Spacer | 26. Deflector |
| 6. Outlet Assembly | 27. Firewall |
| 7. Seal | 28. Housing |
| 8. Bullet Catch | 29. Spring |
| 9. Screw | 30. Arm Assembly |
| 10. Felt Washer | 31. Roll Pin |
| 11. Tube Assembly | 32. Clamp Bolt |
| 12. Elbow Assembly | 33. Nut |
| 13. Tinnerman Nut | 34. Cotter Pin |
| 14. Cabin Air Control | 35. Valve Body |
| 15. Defroster Outlet | 36. Pin |
| 16. Cabin Heat Control | 37. Scoop Door |
| 17. Defroster Hose | 38. Fuselage Skin |
| 18. Left Exhaust Muffler | 39. Screen |
| 19. Air Scoop | 40. Duct |
| 20. Inlet Hose | |
| 21. Heater Hose | |

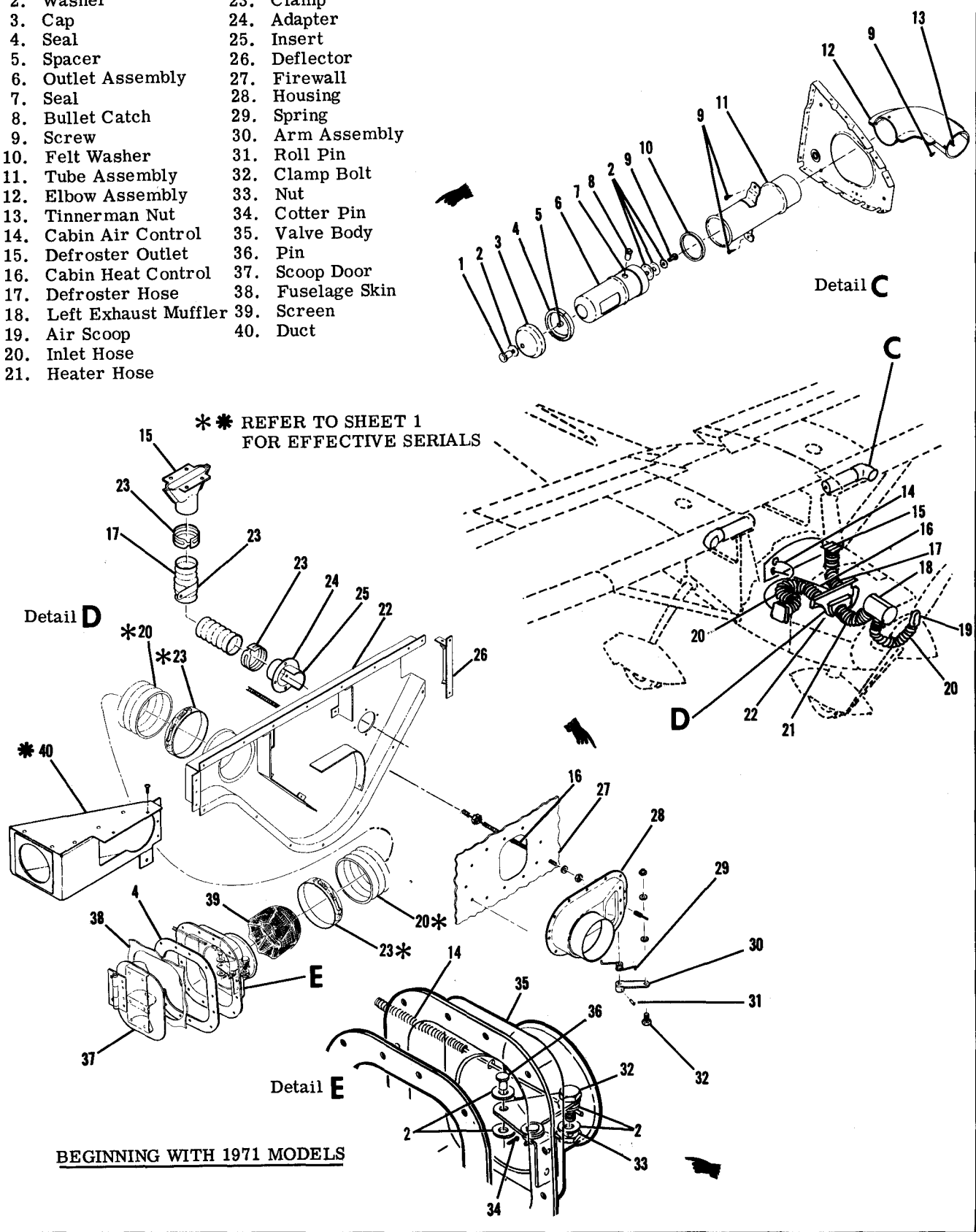

BEGINNING WITH 1971 MODELS

Figure 14-1. Heating, Defrosting, and Ventilating Systems (Sheet 2 of 2)

14-7. DEFROSTER SYSTEM.

14-8. DESCRIPTION. The defrosting system is comprised of a duct across the aft side of the firewall, a defroster outlet, mounted on the left side of the cowl deck immediately aft of the windshield, and flexible ducting connecting the system.

14-9. OPERATION. Air from the duct across the aft side of the firewall flows through a flexible duct to the defroster outlet. The temperature and volume of this air is controlled by the settings of the heater system control.

14-10. TROUBLE SHOOTING. Since the defrosting system depends on proper operation of the heating system, refer to paragraph 14-5 for trouble shooting the heating and defrosting system.

14-11. REMOVAL, INSTALLATION AND REPAIR. Figure 14-1 may be used as a guide for removal, installation and repair of defrosting system components. Cut hose to length and install in the original routing. Trim hose winding shorter than the hose to allow clamps to be fitted. A defective defroster outlet must be repaired or replaced.

14-12. VENTILATING SYSTEM.

14-13. DESCRIPTION. The ventilating system is comprised of an airscoop mounted in the inboard leading edge of each wing, an adjustable ventilator mounted on each side of the cabin near the upper corners of the windshield, a fresh airscoop door mounted on the right side of the fuselage, a control knob on the instrument panel and flexible ducting connecting the system.

14-14. OPERATION. Air received from scoops

mounted in the inboard leading edges of the wings is ducted to adjustable ventilators mounted on each side of the cabin near the upper corners of the windshield. Forward cabin ventilation is provided by a fresh airscoop door mounted on the right side of the fuselage, just forward of the copilot seat. The scoop door is operated by a control in the instrument panel marked "CABIN AIR." Fresh air from the scoop door is routed to the duct across the aft side of the firewall, where it is distributed into the cabin. As long as the "CABIN HEAT" control is pushed in, no heated air can enter the firewall duct; therefore, when the "CABIN AIR" control is pulled out, only fresh air from the scoop will flow through the duct into the cabin. As the "CABIN HEAT" control is gradually pulled out, more and more heated air will blend with the fresh air from the scoop and be distributed into the cabin. Either one, or both of the controls may be set at any position from full open to full closed.

14-15. TROUBLE SHOOTING. Most of the operational troubles in the ventilating system are caused by sticking or binding of the inlet scoop door or its control. Check the airscoop filter elements in the wing leading edges for obstructions. Also, check the filter elements in the inlet scoop door (1971 Models). The elements may be removed and cleaned or replaced. Since air passing through the filters is emitted into the cabin, do not use a cleaning solution which would contaminate cabin air. The filters may be removed to increase air flow. However, their removal will cause a slight increase in noise level.

14-16. REMOVAL, INSTALLATION AND REPAIR. Figure 14-1 may be used as a guide for removal, installation and repair of the ventilating system components. A defective ventilator or scoop door must be repaired or replaced. Check for proper operation of ventilating controls after installation or repair.

SHOP NOTES:

SECTION 15

INSTRUMENTS AND INSTRUMENT SYSTEMS

TABLE OF CONTENTS	Page
INSTRUMENTS AND INSTRUMENT SYSTEMS	15-1
General	15-1
Instrument Panel	15-3
Description	15-3
Removal and Installation	15-3
Shock-Mounts	15-3
Instruments	15-3
Removal	15-3
Installation	15-3
Pitot and Static Systems	15-3
Description	15-3
Maintenance	15-3
Static Pressure System Inspection and Leakage Test	15-3
Pitot System Inspection and Leakage Test	15-5
Blowing Out Lines	15-5
Removal and Installation of Components	15-5
Trouble Shooting-Pitot Static System	15-6
True Airspeed Indicator	15-6
Trouble Shooting	15-6
Trouble Shooting-Altimeter	15-8
Trouble Shooting-Vertical Speed Indicator	15-8
Trouble Shooting-Pitot Tube Heater	15-9
Pitot Tube Alignment	15-9
Vacuum System	15-9
Description	15-9
Trouble Shooting	15-11
Trouble Shooting-Gyros	15-11
Trouble Shooting-Vacuum Pump	15-14
Removal and Installation of Components	15-14
Cleaning	15-14
Vacuum Relief Valve Adjustment	15-14
Engine Indicators	15-14
Tachometer	15-14
Description	15-14
Oil Pressure Gage	15-15
Description	15-15
Trouble Shooting	15-15
Oil Temperature Gage	15-15
Description	15-15
Fuel Quantity Indicating System	15-16
Description	15-16
Removal and Installation	15-16
Trouble Shooting	15-16
Transmitter Calibration	15-17
Hourmeter	15-17
Description	15-17
Magnetic Compass	15-17
Description	15-17
Accelerometer	15-18
Description	15-18
Stall Warning System	15-18
Description	15-18
Turn-and-Slip Indicator	15-19
Description	15-19
Trouble Shooting	15-19
Turn Coordinator	15-20
Description	15-20
Trouble Shooting	15-20
Electric Clock	15-22
Description	15-22
Wing Leveler	15-22
Description	15-22
Rigging	15-22

15-1. INSTRUMENTS AND INSTRUMENT SYSTEMS.

15-2. GENERAL. This section describes typical instrument installations and their respective operating systems. Emphasis is placed on trouble shooting and corrective measures only. It does NOT deal with specific instrument repairs since this usually requires special equipment and data and should be handled by instrument specialists. Federal Aviation Regulations require malfunctioning instruments be sent to an approved instrument overhaul and repair station or returned to manufacturer for servicing. Our concern here is with preventive maintenance on various instrument systems and correction of system faults which result in instrument malfunctions. The descriptive material, maintenance and trouble shooting

information in this section is intended to help the mechanic determine malfunctions and correct them, up to the defective instrument itself, at which point an instrument technician should be called in. Some instruments, such as fuel quantity and oil pressure gages, are so simple and inexpensive, repairs usually will be more costly than a new instrument. On the other hand, aneroid and gyro instruments usually are well worth repairing. The words "replace instrument" in the text, therefore, should be taken only in the sense of physical replacement in aircraft. Whether replacement is to be with a new instrument, an exchange one, or original instrument is to be repaired must be decided on basis of individual circumstances.

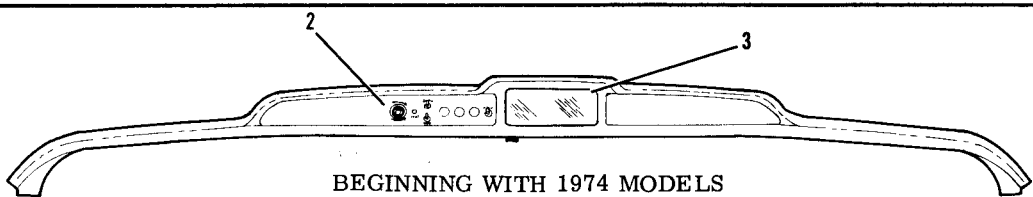

BEGINNING WITH 1974 MODELS

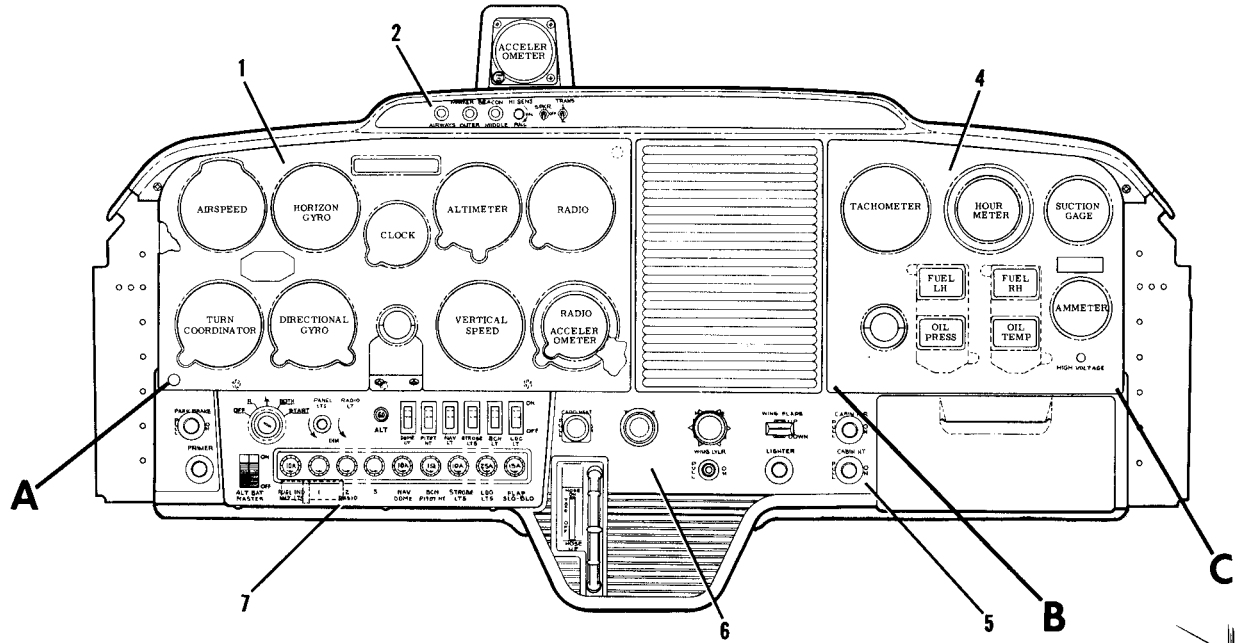

THRU 1973 MODELS

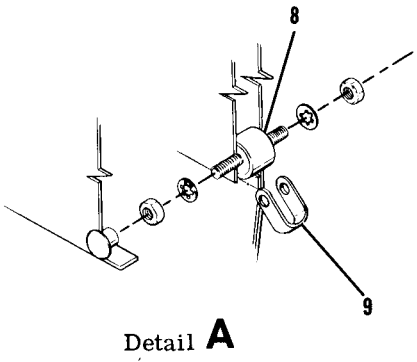

Detail A

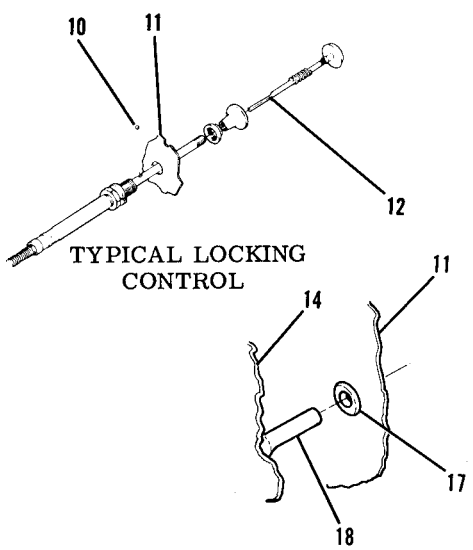

TYPICAL LOCKING CONTROL

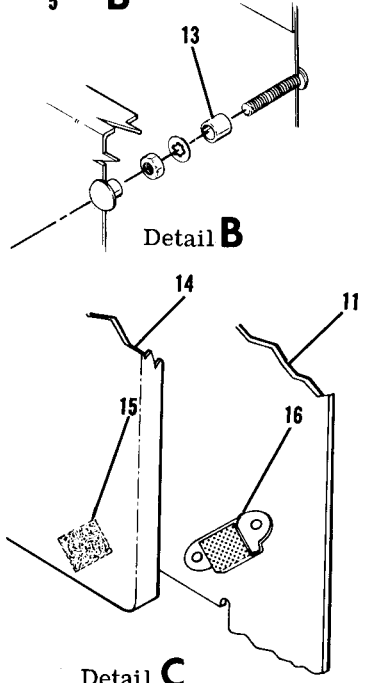

Detail B

Detail C

NOTE POSITION OF GROUND STRAP ON PANEL AND SEQUENCE OF ATTACHING PARTS WHEN REMOVING AND INSTALLING SHOCK PANEL.

- 1. Shock Mounted Panel
- 2. Radio Switch Panel
- 3. Rear View Mirror
- 4. Fuel and Engine Instruments
- 5. Heating and Ventilation Controls
- 6. Engine Controls
- 7. Switch and Circuit Breaker Panel
- 8. Shock Mount
- 9. Ground Strap
- 10. Retainer Ball
- 11. Panel
- 12. Retainer Ball Seat

- 13. Spacer
- 14. Decorative Cover
- 15. Pile
- 16. Hook
- 17. Grommet
- 18. Pin

BEGINNING WITH 1974 MODELS

VELCRO FASTENERS 1972 MODELS THRU 1973 MODELS

Figure 15-1. Typical Instrument Panel (Sheet 1 of 2)

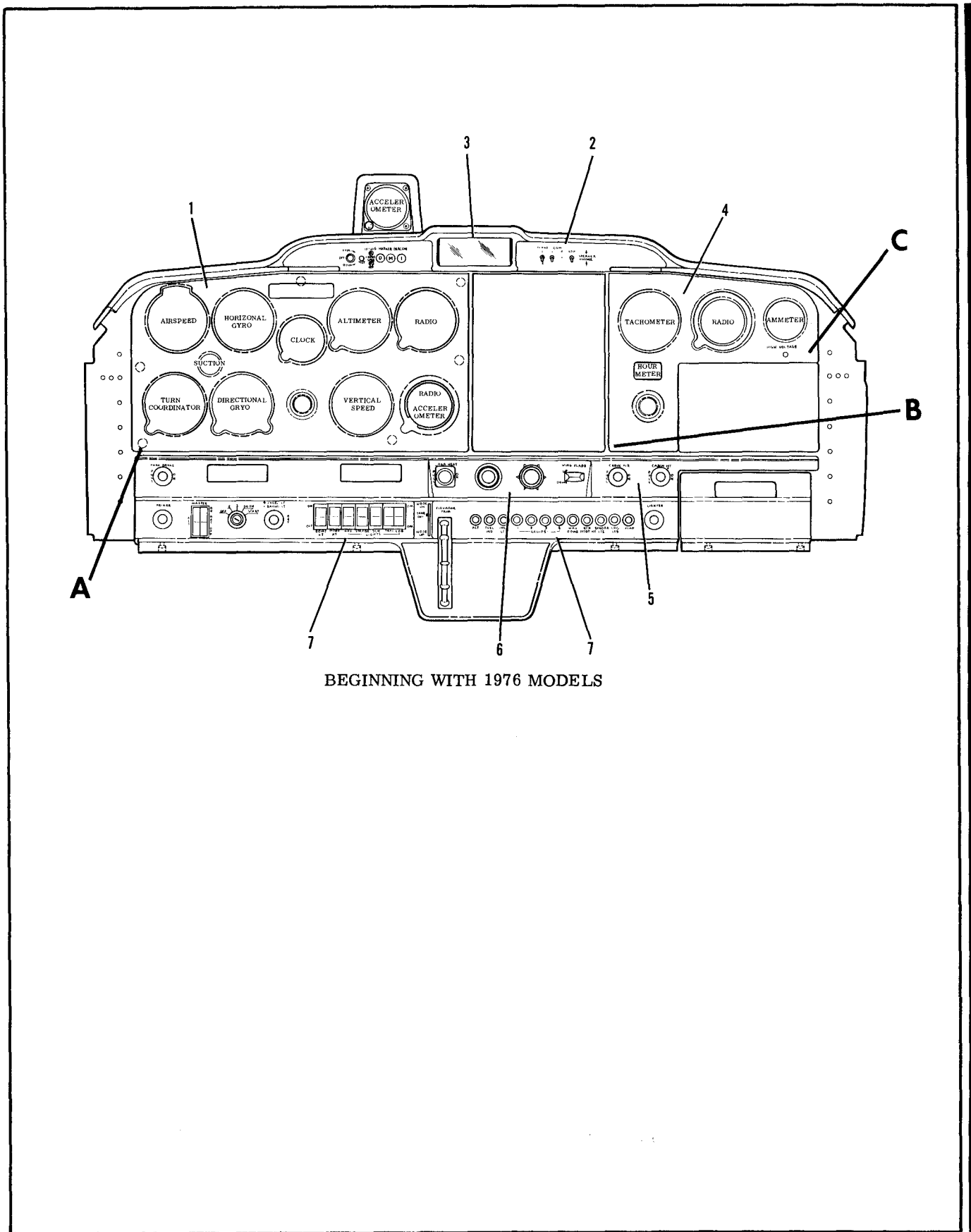

BEGINNING WITH 1976 MODELS

Figure 15-1. Typical Instrument Panel (Sheet 2 of 2)

This page intentionally left blank.

15-3. INSTRUMENT PANEL. (Refer to figure 15-1.)

15-4. DESCRIPTION. The instrument panel assembly consists of a stationary and shock-mounted panel. The stationary panel contains fuel and engine instruments, which are NOT sensitive to vibration. The shock-mounted panel contains major flight instruments such as horizontal and directional gyros which ARE affected by vibration. Most of the instruments are screw-mounted on the panel backs.

15-5. REMOVAL AND INSTALLATION. The stationary panel is secured to engine mount stringers and a forward fuselage bulkhead and ordinarily is not considered removable. The shock-mounted panel is secured to stationary panel with rubber shock-mounted assemblies. To remove shock-mounted panel proceed as follows:

- a. Unscrew threaded buttons securing decorative cover to panel and remove cover.
- b. Remove nuts from shock-mounts, tag and disconnect instrument wiring and plumbing and pull panel straight back.
- c. Reverse preceding steps for installation. Ensure ground strap is properly installed.

15-6. SHOCK MOUNTS. Service life of instruments is directly related to adequate shock-mounting of panel. If removal of panel is necessary, check mounts for deterioration.

15-7. INSTRUMENTS. (Refer to figure 15-1.)

15-8. REMOVAL. Most instruments are secured to panel with screws inserted through panel face. To remove an instrument, remove decorative cover, disconnect wiring or plumbing to instrument, remove mounting screws and take instrument out from behind, or in some cases, from front of panel. Instrument clusters are installed as units and are secured by a screw at each end. A cluster must be removed from panel to replace an individual gage.

NOTE

Thru 1975 models the clusters are located directly above the glove box. Removal of the cluster will be simpler if the glove box is removed first. Beginning with 1976 models, the instrument cluster is located below the pilots control column.

In all cases when an instrument is removed, disconnected lines or wires should be protected. Cap open lines and cover pressure connections on instrument to prevent thread damage and entrance of foreign matter. Wire terminals should be insulated or tied up so accidental grounding or short-circuiting will not occur.

15-9. INSTALLATION. Generally, installation procedure is the reverse of removal procedure. Ensure mounting screw nuts are tightened firmly, but do not over-tighten, particularly on instruments having plastic cases. The same rule applies to connecting plumbing and wiring.

NOTE

All instruments (gages and indicators), requiring a thread seal or lubricant, shall be installed using teflon tape on male fittings only. This tape is available through Cessna Service Parts Center.

When replacing an electrical gage in an instrument cluster assembly, avoid bending pointer or dial plate. Distortion of dial or back plate could change calibration of gages.

15-10. PITOT AND STATIC SYSTEMS. (Refer to figure 15-2.)

15-11. DESCRIPTION. The pitot system conveys ram air pressure to the airspeed indicator. The static system vents vertical speed indicator, altimeter and airspeed indicator to atmospheric pressure through plastic tubing connected to a static port. A static line sump is installed at source button to collect condensation in static system. A pitot tube heater may be installed. The heating element is controlled by a switch at instrument panel and powered by the electrical system.

15-12. MAINTENANCE. Proper maintenance of pitot and static system is essential for proper operation of altimeter, vertical speed and airspeed indicators. Leaks, moisture and obstructions in pitot system will result in false airspeed indications, while static system malfunctions will affect readings of all three instruments. Under instrument flight conditions, these instrument errors could be hazardous. Cleanliness and security are the principal rules for system maintenance. The pitot tube and static ports MUST be kept clean and unobstructed.

15-13. STATIC PRESSURE SYSTEM INSPECTION AND LEAKAGE TEST. The following procedure outlines inspection and testing of static pressure system, assuming altimeter has been tested and inspected in accordance with current Federal Aviation Regulations.

- a. Ensure static system is free from entrapped moisture and restrictions.
- b. Ensure no alterations or deformations of air-frame surface have been made which would affect the relationship between air pressure in static pressure system and true ambient static air pressure for any flight configuration.
- c. Attach a source of suction to static pressure source opening. Figure 15-3 shows one method of obtaining suction.
- d. Slowly apply suction until altimeter indicates a 1000-foot increase in altitude.

CAUTION

When applying or releasing suction, do not exceed range of vertical speed indicator or airspeed indicator.

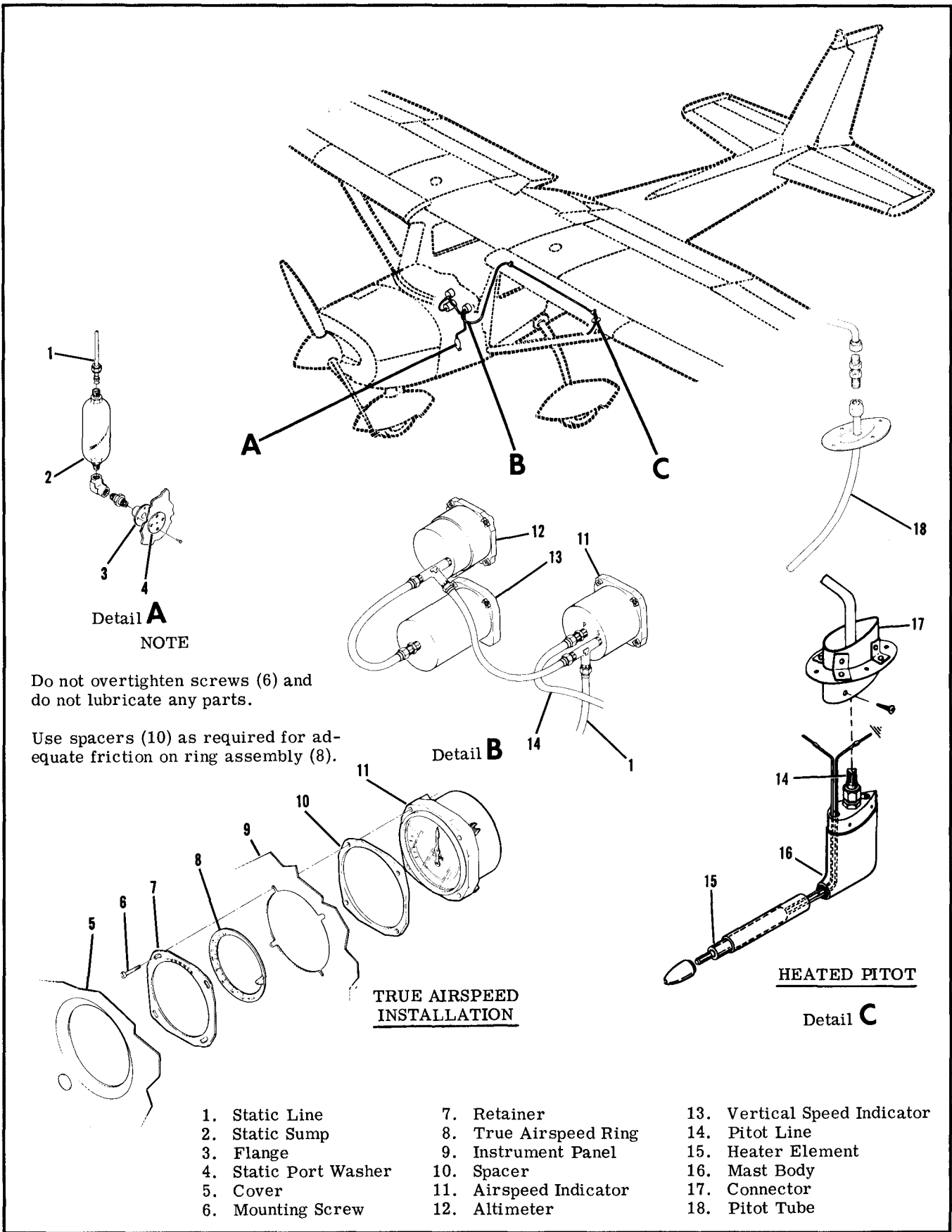

Figure 15-2. Pitot-Static Systems

- e. Cut off suction source to maintain a "closed" system for one minute. Leakage shall not exceed 100 feet of altitude loss as indicated on altimeter.
- f. If leakage rate is within tolerance, slowly release suction source.

NOTE

If leakage rate exceeds maximum allowable, first tighten all connections, then repeat leakage test. If leakage rate still exceeds maximum allowable, use following procedure.

- g. Disconnect static pressure lines from airspeed indicator and vertical speed indicator. Use suitable fittings to connect lines together so altimeter is the only instrument still connected into static pressure system.
- h. Repeat leakage test to check whether static pressure system or the bypassed instruments are cause of leakage. If instruments are at fault, they must be repaired by an "appropriately rated repair station" or replaced. If static pressure system is at fault, use following procedure to locate leakage.
- i. Attach a source of positive pressure to static source opening. Figure 15-3 shows one method of obtaining positive pressure.

CAUTION

Do not apply positive pressure with airspeed indicator or vertical speed indicator connected to static pressure system.

- j. Slowly apply positive pressure until altimeter indicates a 500-foot decrease in altitude and maintain this altimeter indication while checking for leaks. Coat line connections and static source flange with solution of mild soap and water, watching for bubbles to locate leaks.
- k. Tighten leaking connections. Repair or replace parts found defective.
- l. Reconnect airspeed and vertical speed indicators into static pressure system and repeat leakage test per steps "c" thru "f".

15-14. PITOT SYSTEM INSPECTION AND LEAKAGE TEST. To check pitot system for leaks, place a piece of tape over small hole in lower aft end of pitot tube, fasten a piece of rubber or plastic tubing over pitot tube, close opposite end of tubing and slowly roll up tube until airspeed indicator registers in cruise range. Secure tube and after a few minutes recheck airspeed indicator. Any leakage will have reduced the pressure in system, resulting in a lower airspeed indi-

cation. Slowly unroll tubing before removing it, so pressure is reduced gradually. Otherwise instrument may be damaged. If test reveals a leak in system, check all connections for tightness.

15-15. BLOWING OUT LINES. Although pitot system is designed to drain down to pitot tube opening, condensation may collect at other points in system and produce a partial obstruction. To clear line, disconnect at airspeed indicator. Using low pressure air, blow from indicator end of line toward pitot tube.

CAUTION

Never blow through pitot or static lines toward instruments.

Like pitot lines, static pressure lines must be kept clear and connections tight. All models have a static source sump which collects moisture and keeps system clear. However, when necessary, disconnect static line at first instrument to which it is connected, then blow line clear with low-pressure air. Check all static pressure line connections for tightness. If hose or hose connections are used, check for general condition and clamps for security. Replace hose which have cracked, hardened or show other signs of deterioration.

15-16. REMOVAL AND INSTALLATION OF COMPONENTS. (Refer to figure 15-2.) To remove pitot mast remove four mounting screws on side of connector (17) and pull mast out of connector far enough to disconnect pitot line (14). Electrical connections to heater assembly (if installed) may be disconnected through wing access opening just inboard of mast. Pitot and static lines are removed in the usual manner, after removing wing access plates, lower wing fairing strip and upholstery as required. Installation of tubing will be simpler if a guide wire is drawn in as tubing is removed from wing. The tubing may be removed intact by drawing it out through cabin and right door. When replacing fittings of pitot and static pressure lines, use anti-seize compound sparingly on male threads of both metal and plastic connections. Avoid excess compound which might enter lines. Tighten connections firmly, but avoid overtightening and distorting fittings. If twisting of plastic tubing is encountered when tightening fittings, VV-P-236 (USP Petrolatum), may be applied sparingly between tubing and fittings.

15-17. TROUBLE SHOOTING--PITOT STATIC SYSTEM.

TROUBLE	PROBABLE CAUSE	REMEDY
LOW OR SLUGGISH AIRSPEED INDICATION. (Normal altimeter and vertical speed.)	Pitot tube obstructed, leak or obstruction in pitot line.	Test pitot tube and line for leaks or obstructions. Blow out tube and line, repair or replace damaged line.
INCORRECT OR SLUGGISH RESPONSE. (all three instruments.)	Leaks or obstruction in static line.	Test line for leaks and obstructions. Repair or replace line, blow out obstructed line.

15-18. TRUE AIRSPEED INDICATOR. A true airspeed indicator may be installed. This indicator, equipped with a conversion ring, may be rotated until pressure altitude is aligned with outside air temperature, then airspeed indicated on the instrument is read as true airspeed on the adjustable ring. Refer to figure 15-2 for removal and installation. Upon installation, before tightening mounting screws (6), calibrate instrument as follows: Rotate ring (8) until 120 mph on the adjustable ring aligns with 120 mph on the indicator. Holding this setting, move retainer (7) until

60°F aligns with zero pressure altitude, then tighten mounting screws (6) and replace decorative cover (5).

NOTE

Beginning with 1976 models, true airspeed indicators are graduated in knots. Therefore, on these aircraft, use 105K instead of 120MPH in the above calibration procedure.

15-19. TROUBLE SHOOTING--AIRSPEED INDICATOR.

TROUBLE	PROBABLE CAUSE	REMEDY
HAND FAILS TO RESPOND.	Pitot pressure connection not properly connected to pressure line from pitot tube.	Test line and connection for leaks. Repair or replace damaged line, tighten connections.
	Pitot or static lines clogged.	Check line for obstructions. Blow out lines.
INCORRECT INDICATION OR HAND OSCILLATES.	Leak in pitot or static lines.	Test lines and connections for leaks. Repair or replace damaged lines, tighten connections.
	Defective mechanism or leaking diaphragm.	Substitute known-good indicator and check reading. Replace instrument.
HAND VIBRATES.	Excessive vibration.	Check panel shock mounts. Replace defective shock mounts.
	Excessive tubing vibration.	Check clamps and line connections for security. Tighten clamps and connections, replace tubing with flexible hose.

NOTE

Air bulb with check valves may be obtained locally from a surgical supply company. This is the type used in measuring blood pressure.

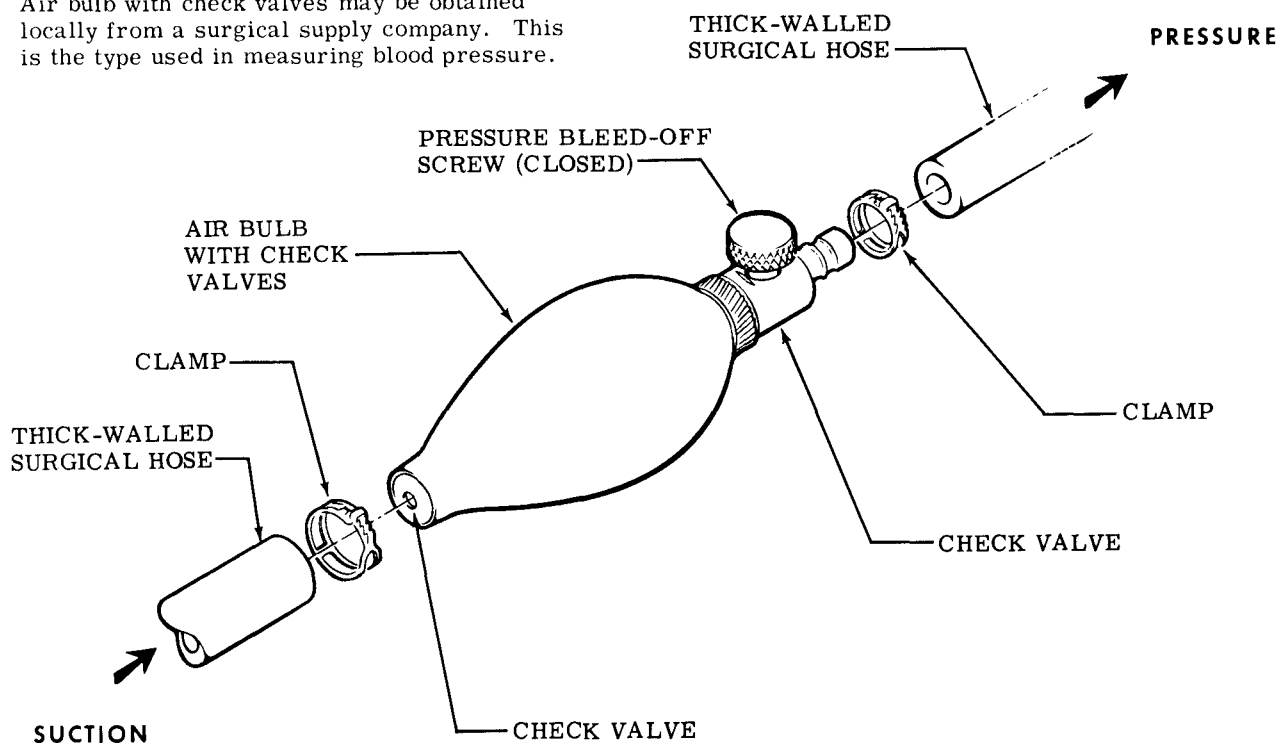

TO APPLY SUCTION:

1. Squeeze air bulb to expel as much air as possible.
2. Hold suction hose firmly against static pressure source opening.
3. Slowly release air bulb to obtain desired suction, then pinch hose shut tightly to trap suction in system.
4. After leak test, release suction slowly by intermittently allowing a small amount of air to enter static system. To do this, tilt end of suction hose away from opening, then immediately tilt it back against opening. Wait until vertical speed indicator approaches zero, then repeat. Continue to admit this small amount of air intermittently until all suction is released, then remove test equipment.

TO APPLY PRESSURE:

CAUTION

Do not apply positive pressure with airspeed indicator or vertical speed indicator connected into static system.

1. Hold pressure hose firmly against static pressure source opening.
2. Slowly squeeze air bulb to apply desired pressure to static system. Desired pressure may be maintained by repeatedly squeezing bulb to replace any air escaping through leaks.
3. Release pressure by slowly opening pressure bleed-off screw, then remove test equipment.

Figure 15-3. Static Test Equipment

15-20. TROUBLE SHOOTING--ALTIMETER

TROUBLE	PROBABLE CAUSE	REMEDY
INSTRUMENT FAILS TO OPERATE.	Static line plugged.	Check line for obstructions. Blow out lines.
	Defective mechanism.	Substitute known-good altimeter and check reading. Replace instrument.
INCORRECT INDICATION.	Hands not carefully set.	Reset hands with knob.
	Leaking diaphragm.	Substitute known-good altimeter and check reading. Replace instrument.
	Pointers out of calibration.	Compare reading with known-good altimeter. Replace instrument.
HAND OSCILLATES.	Static pressure irregular.	Check lines for obstruction or leaks. Blow out lines, tighten connections.
	Leak in airspeed or vertical speed indicator installations.	Check other instruments and system plumbing for leaks. Blow out lines, tighten connections.

15-21. TROUBLE SHOOTING--VERTICAL SPEED INDICATOR.

TROUBLE	PROBABLE CAUSE	REMEDY
INSTRUMENT FAILS TO OPERATE.	Static line plugged.	Check line for obstructions. Blow out lines.
	Static line broken.	Check line for damage, connections for security. Repair or replace damaged line, tighten connections.
INCORRECT INDICATION.	Partially plugged static line.	Check line for obstructions. Blow out lines.
	Ruptured diaphragm.	Substitute known-good indicator and check reading. Replace instrument.
	Pointer off zero.	Reset pointer to zero. Reset pointer to zero.
POINTER OSCILLATES.	Partially plugged static line.	Check line for obstructions. Blow out lines.

15-21. TROUBLE SHOOTING--VERTICAL SPEED INDICATOR. (Cont)

TROUBLE	PROBABLE CAUSE	REMEDY
POINTER OSCILLATES. (cont).	Leak in static line.	Test lines and connections for leaks. Repair or replace damaged lines, tighten connections.
	Leak in instrument case.	Substitute known-good indicator and check reading. Replace instrument.
HAND VIBRATES.	Excessive vibration.	Check shock mounts. Replace defective shock mounts.
	Defective diaphragm.	Substitute known-good indicator and check for vibration. Replace instrument.

15-22. TROUBLE SHOOTING--PITOT TUBE HEATER.

TROUBLE	PROBABLE CAUSE	REMEDY
TUBE DOES NOT HEAT OR CLEAR ICE.	Switch turned "OFF."	Turn switch "ON."
	Blown fuse.	Check fuse. Replace fuse.
	Break in wiring.	Test for open circuit. Repair wiring.
	Heating element burned out.	Check resistance of heating element. Replace element.

15-23. PITOT TUBE ALIGNMENT. (Refer to figure 15-2.) For correct airspeed indication pitot tube (18) must be properly aligned. Open end of tube must be perpendicular to longitudinal axis of aircraft. A template like the one shown in figure 15-4 will prove the most convenient means of checking alignment. Prior to using template, check that pitot tube parallels row of rivets just outboard of tube. A straightedge may be placed along row of rivets to check the alignment. The template fits over the wing leading edge and should conform to the illustration. The illustration has been drawn carefully to actual size and may be traced directly on a piece of carbon paper between the printed page and the template material, then trace contours.

15-24. VACUUM SYSTEM. (Refer to figure 15-5.)

15-25. DESCRIPTION. Suction to operate the gyros is provided by a dry-type engine-driven vacuum pump, gear-driven through a spline-type coupling. A suction relief valve, to control system pressure, is connected between the pump inlet and the instruments. In the cabin, the vacuum line is routed from gyro instruments to the relief valve at the firewall. A central air filtering system is utilized. Beginning with aircraft serial 15075525 and A1500480 a throw away type air filtering unit is installed. The unit is installed with sta-straps for quick change capability. The reading of the suction gage indicates net difference in suction before and after air passes through a gyro. This differential pressure will gradually decrease as the central air filter becomes dirty, causing a lower reading on the suction gage.

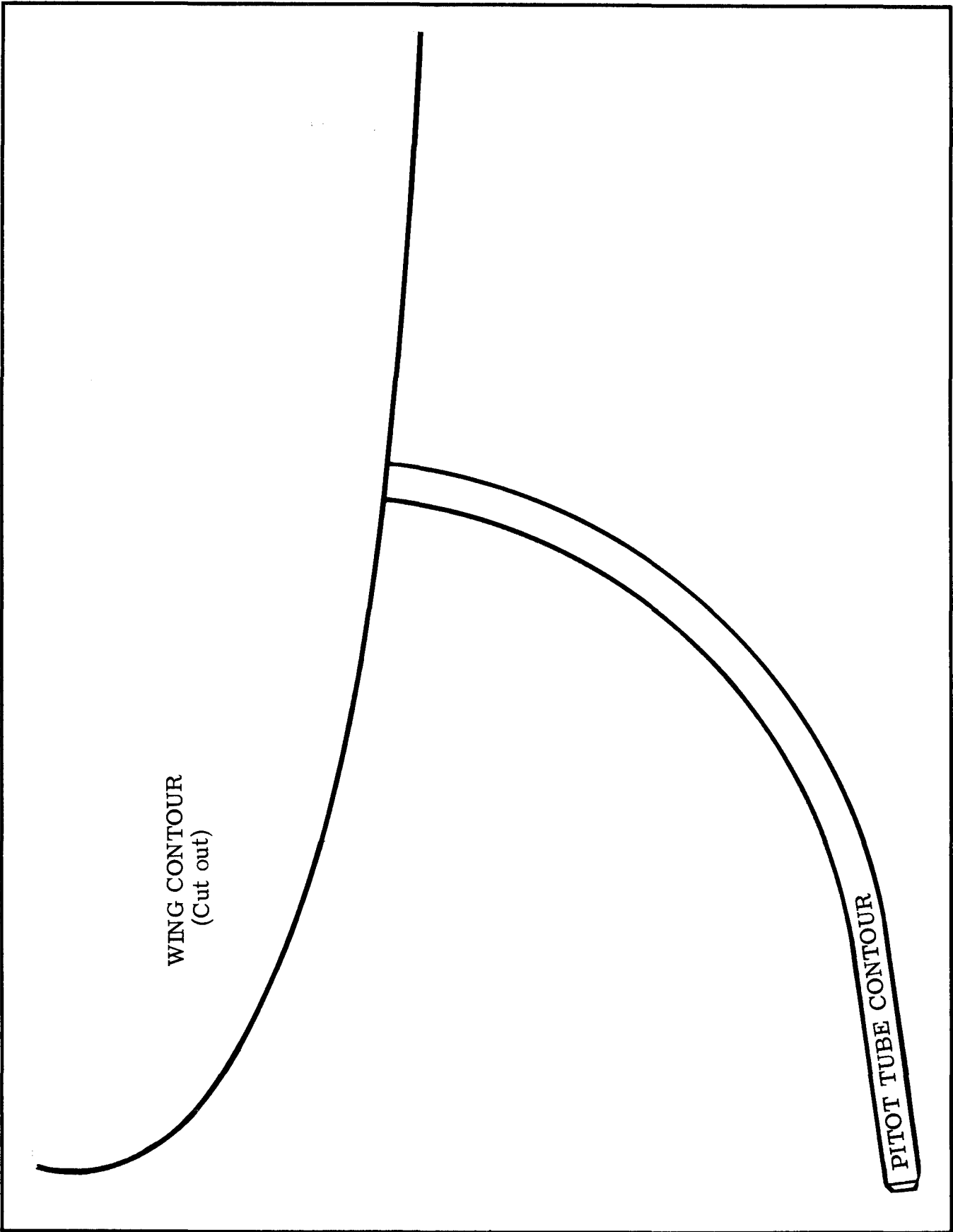

Figure 15-4. Pitot Tube Alignment Template

15-26. TROUBLE SHOOTING--VACUUM SYSTEM

TROUBLE	PROBABLE CAUSE	REMEDY
HIGH SUCTION GAGE READINGS.	Gyros function normally-relief valve screen clogged, relief valve malfunction.	Check screen, than valve. Compare gage readings with new gage. Clean screen, reset valve. Replace gage.
NORMAL SUCTION GAGE READING, SLUGGISH OR ERRATIC GYRO RESPONSE.	Instrument air filters clogged.	Check operation with filters removed. Replace filters.
LOW SUCTION GAGE READINGS.	Leaks or restriction between instruments and relief valve, relief valve out of adjustment, defective pump.	Check lines for leaks, disconnect and test pump. Repair or replace lines, adjust or replace relief valve, repair or replace pump.
	Central air filter dirty.	Check operation with filter removed. Clean or replace filter.
SUCTION GAGE FLUCTUATES.	Defective gage or sticking relief valve.	Check suction with test gage. Replace gage. Clean sticking valve with Stoddard solvent. Blow dry and test. If valve sticks after cleaning, replace valve.

15-27. TROUBLE SHOOTING--GYROS.

TROUBLE	PROBABLE CAUSE	REMEDY
HORIZON BAR FAILS TO RESPOND.	Central filter dirty.	Check filter. Clean or replace filter.
	Suction relief valve improperly adjusted.	Adjust or replace relief valve.
	Faulty suction gage.	Substitute known-good suction gage and check gyro response. Replace suction gage.
	Vacuum pump failure.	Check pump. Replace pump.
	Vacuum line kinked or leaking.	Check lines for damage and leaks. Repair or replace damaged lines, tighten connections.
HORIZON BAR DOES NOT SETTLE.	Defective mechanism.	Substitute known-good gyro and check indication. Replace instrument.
	Insufficient vacuum.	Adjust or replace relief valve.
	Excessive vibration.	Check panel shock-mounts. Replace defective shock-mounts.

15-27. TROUBLE SHOOTING--GYROS. (Cont).

TROUBLE	PROBABLE CAUSE	REMEDY
HORIZON BAR OSCILLATES OR VIBRATES EXCESSIVELY.	Central filter dirty.	Check filter. Clean or replace filter.
	Suction relief valve improperly adjusted.	Adjust or replace relief valve.
	Faulty suction gage.	Substitute known-good suction gage and check gyro indication. Replace suction gage.
	Defective mechanism.	Substitute known-good gyro and check indication. Replace instrument.
	Excessive vibration.	Check panel shock-mounts. Replace defective shock-mounts.
EXCESSIVE DRIFT IN EITHER DIRECTION.	Central air filter dirty.	Check filter. Clean or replace filter.
	Low vacuum, relief valve improperly adjusted.	Adjust or replace relief valve.
	Faulty suction gage.	Substitute known-good suction gage and check gyro indication. Replace suction gage.
	Vacuum pump failure.	Check pump. Replace pump.
	Vacuum line kinked or leaking.	Check lines for damage and leaks. Repair or replace damaged lines, tighten connections.
DIAL SPINS IN ONE DIRECTION CONTINUOUSLY.	Operating limits have been exceeded.	Replace instrument.
	Defective mechanism.	Substitute known-good gyro and check indication. Replace instrument.

SHOP NOTES:

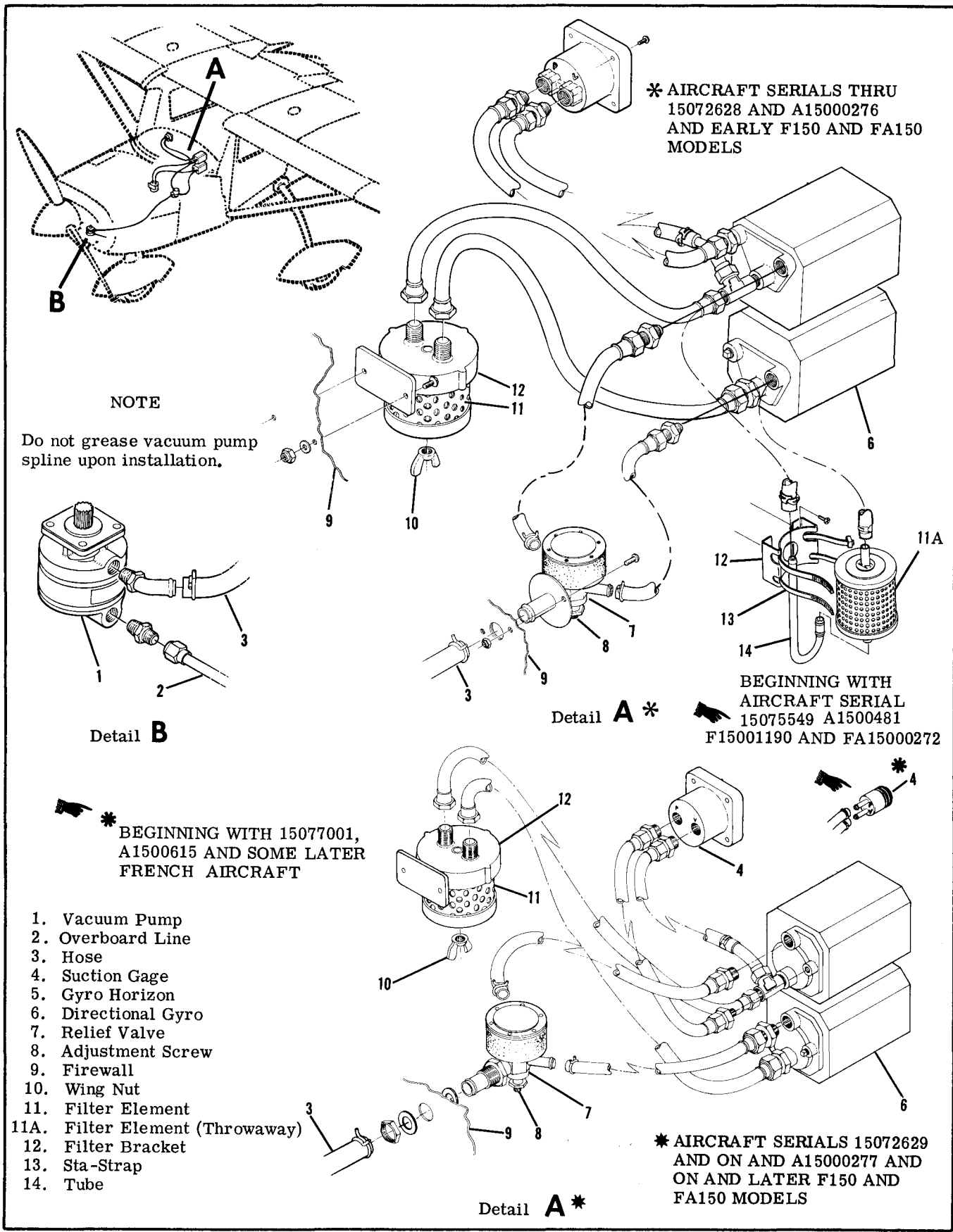

1. Vacuum Pump
2. Overboard Line
3. Hose
4. Suction Gage
5. Gyro Horizon
6. Directional Gyro
7. Relief Valve
8. Adjustment Screw
9. Firewall
10. Wing Nut
11. Filter Element
- 11A. Filter Element (Throwaway)
12. Filter Bracket
13. Sta-Strap
14. Tube

Figure 15-5. Vacuum System

15-28. TROUBLE SHOOTING--VACUUM PUMP.

TROUBLE	PROBABLE CAUSE	REMEDY
OIL IN DISCHARGE.	Damaged engine drive seal.	Replace gasket.
HIGH SUCTION.	Suction relief valve filter clogged.	Check filter for obstructions. Clean or replace filter.
LOW SUCTION.	Relief valve leaking.	Replace relief valve.
	Vacuum pump failure.	Substitute known-good pump and check pump suction. Replace vacuum pump.
LOW PRESSURE.	Safety valve leaking.	Replace safety valve.
	Vacuum pump failure.	Substitute known-good pump and check pump pressure. Replace vacuum pump.

15-29. REMOVAL AND INSTALLATION OF COMPONENTS. The various components of vacuum system are secured by conventional clamps, mounting screws and nuts. To remove a component, remove mounting screws and disconnect inlet and discharge lines. When replacing a vacuum system component, ensure connections are made correctly. Use no thread-lube on any connections. Teflon tape may be used on male threads. Avoid over-tightening connections. Before re-installing a vacuum pump, place mounting pad gasket over studs. After installing pump, before connecting plumbing, start engine and check for evidence of oil in the discharge which would indicate a leaking engine drive seal.

15-30. CLEANING. In general, low-pressure, dry compressed air should be used in cleaning vacuum system components. Suction relief valve, exposed to engine oil and dirt, should be washed with Stoddard solvent, then dried with a low-pressure air blast. Check hose for collapsed inner liners as well as external damage.

CAUTION

Never apply compressed air to lines or components installed in aircraft. The excessive pressures will damage gyros. If an obstructed line is to be blown out, disconnect at both ends and blow from instrument panel out.

15-31. VACUUM RELIEF VALVE ADJUSTMENT. A suction gage reading of 5.3 inches of mercury is desirable for gyro instruments. However, a range of 4.6 to 5.4 inches of mercury is acceptable. To adjust the relief valve, remove control air filter, run engine to 1900 rpm on the ground and adjust relief valve to 5.3 ± .1 inches of mercury.

CAUTION

Do not exceed maximum engine temperature.

Be sure filter element is clean before installing. If reading drops noticeably, install new filter element.

15-32. ENGINE INDICATORS.

15-33. TACHOMETER.

15-34. DESCRIPTION. The tachometer used on Cessna single-engine aircraft is a mechanical indicator driven at half crankshaft speed by a flexible shaft. Most tachometer difficulties will be found in the drive-shaft. To function properly, shaft housing must be free of kinks, dents and sharp bends. There should be no bend on a radius shorter than six inches and no bend within three inches of either terminal. If a tachometer is noisy or pointer oscillates, check cable housing for kinks, sharp bends and damage. Disconnect cable at tachometer and pull it out of housing. Check cable for worn spots, breaks and kinks.

NOTE

Before replacing a tachometer cable in housing, coat lower two thirds with AC Type ST-640 speedometer cable grease or Lubriplate No. 110. Insert cable in housing as far as possible, then slowly rotate to make sure it is seated in engine fitting. Insert cable in tachometer, making sure it is seated in drive shaft, then reconnect housing and torque to 50 pound-inches (at instrument).

15-35. OIL PRESSURE GAGE.

15-36. DESCRIPTION. The Bourdon tube-type oil pressure gage is a direct-reading instrument, operated by a pressure pickup line connected to the engine main oil gallery. The oil pressure line from the instrument to the engine should be filled with kerosene, especially during cold weather operation, to attain an immediate oil indication.

15-37. TROUBLE SHOOTING.

TROUBLE	PROBABLE CAUSE	REMEDY
GAGE DOES NOT REGISTER.	Pressure line clogged.	Check line for obstructions. Clean line.
	Pressure line broken.	Check line for leaks and damage. Repair or replace damaged line.
	Fractured Bourdon tube.	Replace instrument.
	Gage pointer loose on staff.	Replace instrument.
	Damaged gage movement.	Replace instrument.
GAGE POINTER FAILS TO RETURN TO ZERO.	Foreign matter in line.	Check line for obstructions. Clean line.
	Foreign matter in Bourdon tube.	Replace instrument.
	Bourdon tube stretched.	Replace instrument.
GAGE DOES NOT REGISTER PROPERLY.	Faulty mechanism.	Replace instrument.
GAGE HAS ERRATIC OPERATION.	Worn or bent movement.	Replace instrument.
	Foreign matter in Bourdon tube.	Replace instrument.
	Dirty or corroded movement.	Replace instrument.
	Pointer bent and rubbing on dial, dial screw or glass.	Replace instrument.
	Leak in pressure line.	Check line for leaks and damage. Repair or replace damaged line.

15-38. OIL TEMPERATURE GAGE.

15-39. DESCRIPTION. The oil temperature gage is a Bourdon-type pressure instrument connected by armored capillary tubing to a temperature bulb in the engine. The temperature bulb, capillary tube and gage are filled with fluid and sealed. Expansion and contraction of fluid in the bulb with temperature

changes operates gage. Checking capillary tube for damage and fittings for security is the only maintenance required. Since the tube's inside diameter is quite small, small dents and kinks which would be quite acceptable in larger tubing may partially or completely close off capillary, making gage inoperative.

15-40. FUEL QUANTITY INDICATING SYSTEM.

15-41. DESCRIPTION. The magnetic type fuel quantity indicators are used in conjunction with a float-operated variable-resistance transmitter in each fuel tank. The full position of float produces a minimum resistance through transmitter, permitting maximum current flow through the fuel quantity indicator and maximum pointer deflection. As fuel level is lowered, resistance in transmitter is increased, producing a decreased current flow through fuel quantity indicator and a smaller pointer deflection.

- b. Remove access plate above fuel tank for access to transmitter.
- c. Disconnect electrical lead and ground strap from transmitter.
- d. Remove screws attaching transmitter and carefully work transmitter from tank. DO NOT BEND FLOAT ARM.
- e. Install transmitter by reversing preceding steps, using new gaskets around opening in fuel tank and under screw heads.
- f. Service fuel tanks. Check for leaks and correct quantity indication.

15-41A. REMOVAL AND INSTALLATION OF FUEL QUANTITY TRANSMITTERS.

- a. Drain fuel from tank. (Observe precautions in Section 12.

NOTE

Ensure transmitter is properly grounded in accordance with Section 12.

15-42. TROUBLE SHOOTING.

TROUBLE	PROBABLE CAUSE	REMEDY
FAILURE TO INDICATE.	No power to indicator or transmitter. (Pointer stays below E.)	Check fuse and inspect for open circuit. Replace fuse, repair or replace defective wire.
	Grounded wire. (Pointer stays above F.)	Check for partial ground between transmitter and gage. Repair or replace defective wire.
	Low voltage.	Check voltage at indicator. Correct voltage.
	Defective indicator.	Substitute known-good indicator. Replace indicator.
OFF CALIBRATION.	Defective indicator.	Substitute known-good indicator. Replace indicator.
	Defective transmitter.	Substitute known-good transmitter. Recalibrate or replace.
	Low or high voltage.	Check voltage at indicator. Correct voltage.
STICKY OR SLUGGISH INDICATOR OPERATION.	Defective indicator.	Substitute known-good indicator. Replace indicator.
	Low voltage.	Check voltage at indicator. Correct voltage.
ERRATIC READINGS.	Loose or broken wiring on indicator or transmitter.	Inspect circuit wiring. Repair or replace defective wire.
	Defective indicator or transmitter.	Substitute known-good component. Replace indicator or transmitter.
	Defective master switch.	Replace switch.

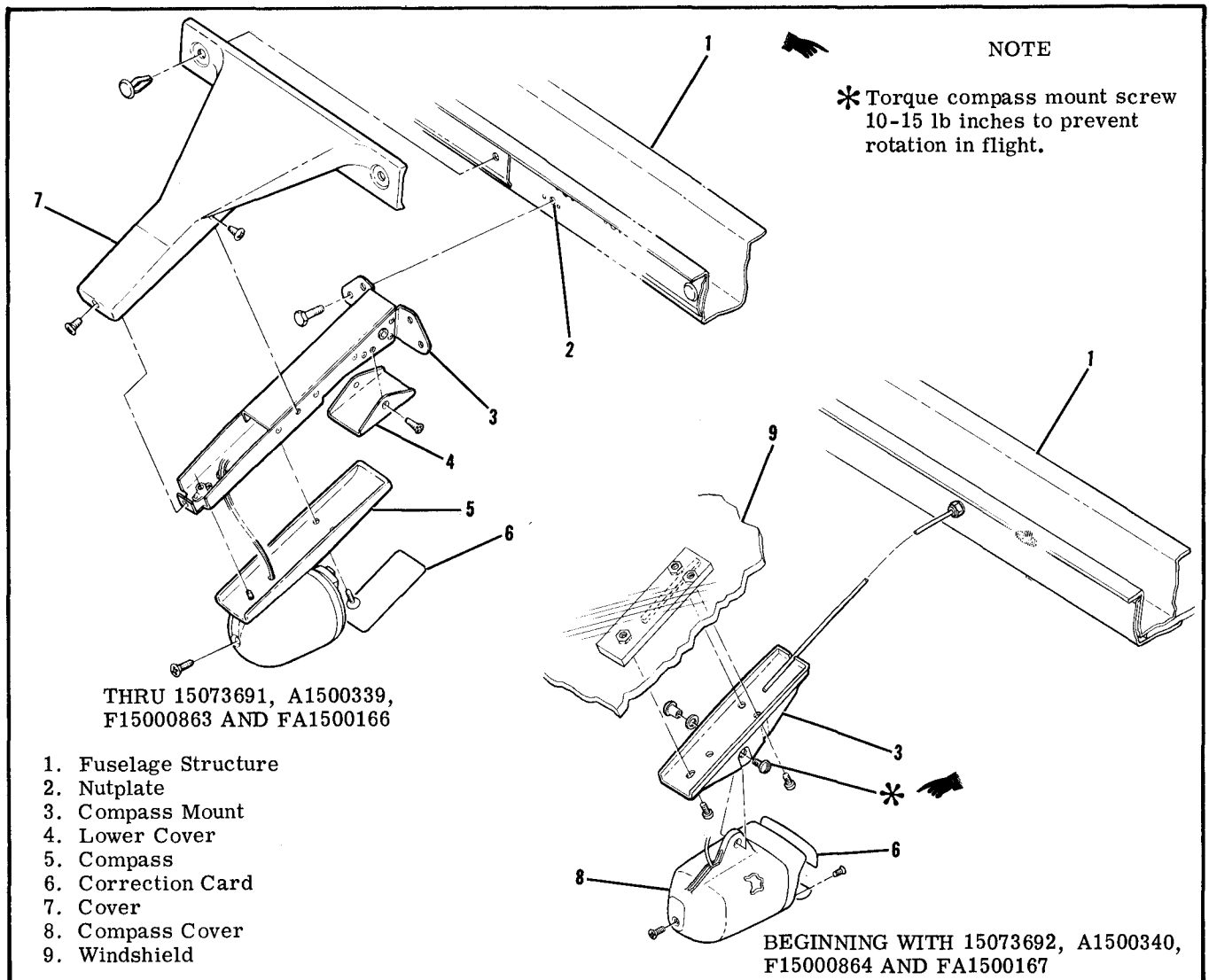

Figure 15-6. Magnetic Compass

15-43. TRANSMITTER CALIBRATION. Chances of transmitter calibration changing in normal service is remote, however, it is possible that float arm or float arm stops may become bent if transmitter is removed from tank. Transmitter calibration is obtained by adjusting float travel. Float travel is limited by float arm stops.

WARNING

Use extreme caution while working with electrical components of fuel system. The possibility of electrical sparks around an "empty" fuel tank creates a hazardous situation.

Before installing transmitter, attach electrical wires and place master switch in "ON" position. Allow float arm to rest against lower float arm stop and read indicator. The pointer should be on E (empty) position. Adjust lower stop with float arm against stop so that pointer indicator is on E (empty). Raise float until arm is against upper stop and adjust stop to permit indicator pointer to be on F (full). Install

transmitter in accordance with Section 12.

15-44. HOURMETER.

15-45. DESCRIPTION. The hourmeter is electrically operated and is actuated by a pressure switch in the oil pressure gage line. Electrical power is supplied through a one-amp fuse from the electrical clock circuit and therefore, will operate independent of the master switch.

15-46. MAGNETIC COMPASS. (Refer to figure 15-6.)

15-47. DESCRIPTION. The magnetic compass is liquid-filled, with expansion provisions to compensate for temperature changes. It is equipped with compensating magnets adjustable from front of case. The compass is internally lighted, controlled by the panel lights rheostat. No maintenance is required on compass except on occasional check on a compass rose for adjustment of compensation and replacement of lamp.

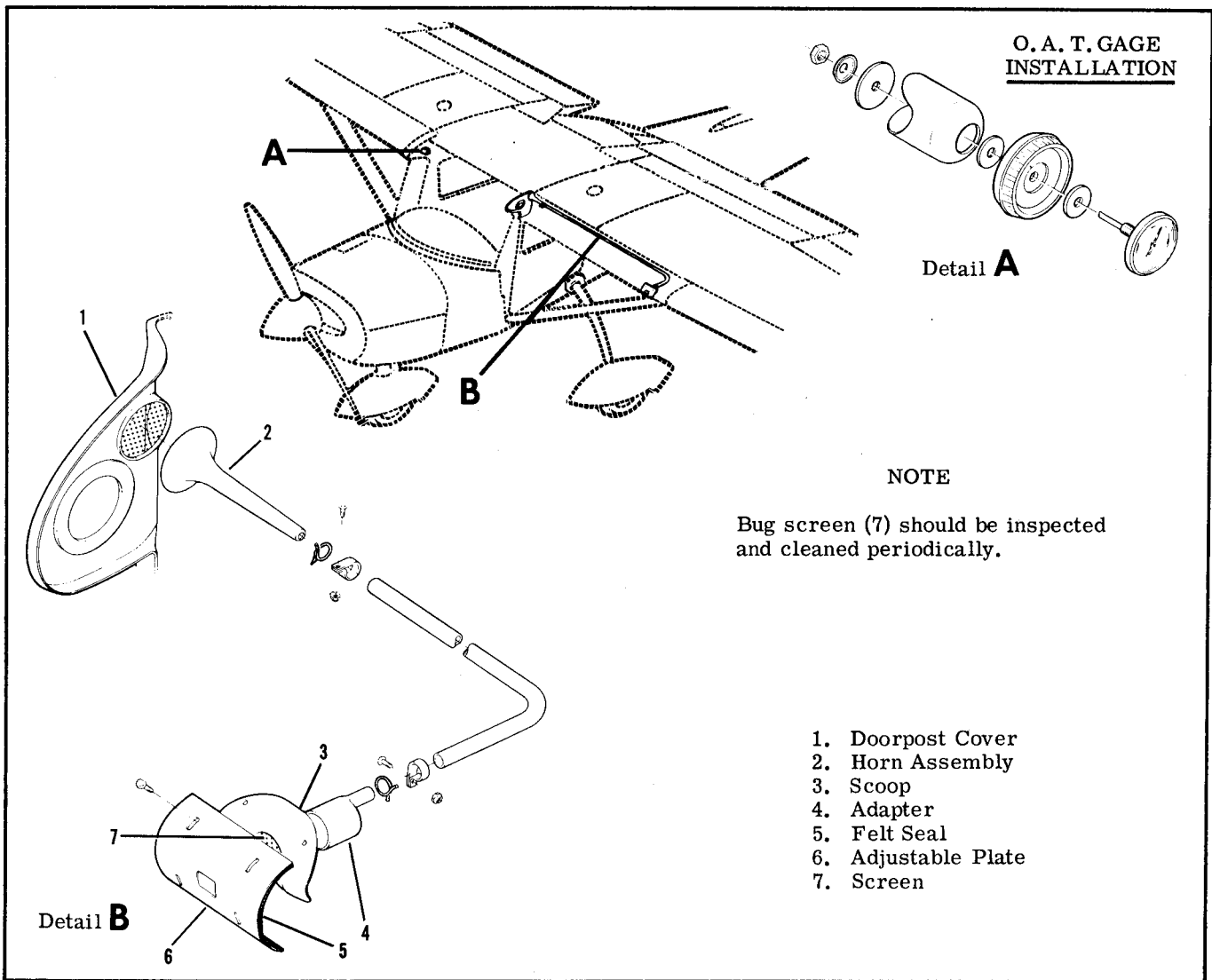

Figure 15-7. Stall Warning System

15-48. ACCELEROMETER.

15-49. DESCRIPTION. The Aerobat offers an accelerometer to assist pilot in performing precision aerobatics. The accelerometer continuously indicates g forces being imposed on aircraft. The dial display utilizes three pointers; one pointer indicates instantaneous acceleration, another records maximum positive acceleration and the third records maximum negative acceleration. Maximum instrument markings range from 10G to 5G. A "PUSH TO SET" knob, located on lower left corner of instrument, is used to reset "Maximum Positive" and "Maximum Negative" pointers. If dual Nav/Coms are installed, the accelerometer is installed in a housing above instrument panel on pilot's side. When aircraft is equipped with single Nav/Com, accelerometer is installed in the vacant Omni indicator instrument space.

15-50. STALL WARNING SYSTEM. (Refer to figure 15-7.)

15-51. DESCRIPTION. The system is composed of an adjustable plate on left wing leading edge, connected to a reed type horn by means of plastic tubing. The horn is actuated approximately 5 to 10 miles per hour above stalling speed as a negative air pressure area at wing leading edge causes a reverse flow of air through horn. By moving adjustable plate (6) up, actuation of horn will occur at a higher speed and moving plate down causes actuation to occur at a slower speed. Center adjustable plate opening in wing leading edge upon installation, then flight test aircraft, observing horn actuation during stall. Re-adjust plate to obtain desired results if necessary. Approximately 3/32 inch adjustment of plate will change speed at which horn actuation occurs by 5 miles per hour. To test horn operation, cover opening in plate (6) with a clean cloth, such as a handkerchief and apply a slight suction by mouth to draw air through horn.

15-52. TURN-AND-SLIP INDICATOR.

is an electrically operated instrument powered by the aircraft electrical system, therefore, operating only when the master switch is ON.

15-53. DESCRIPTION. The turn-and-slip indicator

15-54. TROUBLE SHOOTING.

TROUBLE	PROBABLE CAUSE	REMEDY
INDICATOR POINTER FAILS TO RESPOND.	Internal fuse blown.	Check wiring for continuity, check voltage at indicator. Replace fuse, if fuse still blows, replace instrument.
	Master switch "OFF" or switch defective.	Check switch "ON." Replace defective switch.
	Broken or grounded lead to indicator.	Check circuit wiring. Repair or replace defective wiring.
	Indicator not grounded.	Check ground wire. Repair or replace defective wire.
	Defective mechanism.	Replace instrument.
HAND SLUGGISH IN RETURNING TO ZERO.	Defective mechanism.	Replace instrument.
	Low voltage.	Check voltage at indicator. Correct voltage.
POINTER DOES NOT INDICATE PROPER TURN.	Defective mechanism.	Replace instrument.
HAND DOES NOT SIT ON ZERO.	Gimbal and rotor out of balance.	Replace instrument.
	Hand incorrectly sits on rod.	Replace instrument.
	Sensitivity spring adjustment pulls hand off zero.	Replace instrument.
IN COLD TEMPERATURES, HAND FAILS TO RESPOND OR IS SLUGGISH.	Oil in indicator becomes too thick.	Replace instrument.
	Insufficient bearing end play.	Replace instrument.
	Low voltage.	Check voltage at indicator. Correct voltage.
NOISY GYRO.	High voltage.	Check voltage at indicator. Correct voltage.
	Loose or defective rotor bearings.	Replace instrument.

15-55. TURN COORDINATOR.

15-56. DESCRIPTION. The turn coordinator is an electrically operated, gyroscopic, roll-rate turn indicator. Its gyro simultaneously senses rate of

motion roll and yaw axes which is projected on a single indicator. The gyro is a non-tumbling type requiring no caging mechanism and incorporates an a. c. brushless spin motor with a solid state inverter.

15-57. TROUBLE SHOOTING.

TROUBLE	PROBABLE CAUSE	REMEDY
INDICATOR DOES NOT RETURN TO CENTER.	Friction caused by contamination in the indicator damping.	Replace instrument.
	Friction in gimbal assembly.	Replace instrument.
DOES NOT INDICATE A STANDARD RATE TURN (TOO SLOW).	Low voltage.	Measure voltage at instrument. Correct voltage.
	Inverter frequency changed.	Replace instrument.
NOISY MOTOR.	Faulty bearings.	Replace instrument.
ROTOR DOES NOT START.	Faulty electrical connection.	Check continuity and voltage. Correct voltage or replace faulty wire.
	Inverter malfunctioning.	Replace instrument.
	Motor shorted.	Replace instrument.
	Bearings frozen.	Replace instrument.
IN COLD TEMPERATURES, HAND FAILS TO RESPOND OR IS SLUGGISH.	Oil in indicator becomes too thick.	Replace instrument.
	Insufficient bearing end play.	Replace instrument.
	Low voltage.	Check voltage at instrument. Correct voltage.
NOISY GYRO.	High voltage.	Check voltage to instrument. Correct voltage.
	Loose or defective rotor bearings.	Replace instrument.

1. Right Aileron Vacuum Hose
2. Servo
3. Rudder Cable
4. Left Aileron Vacuum Hose
5. Rudder Vacuum Hose
6. Pulley
7. Aileron Cable
8. Connector
9. Spring
10. Clamp

11. Bellcrank
12. Suction Gage
13. Restrictor Valve
14. ON-OFF Control
15. Turn Coordinator
16. Roll Trim Knob
17. Inverter
18. Vacuum Relief Valve
19. Filter
20. Gyro Hose

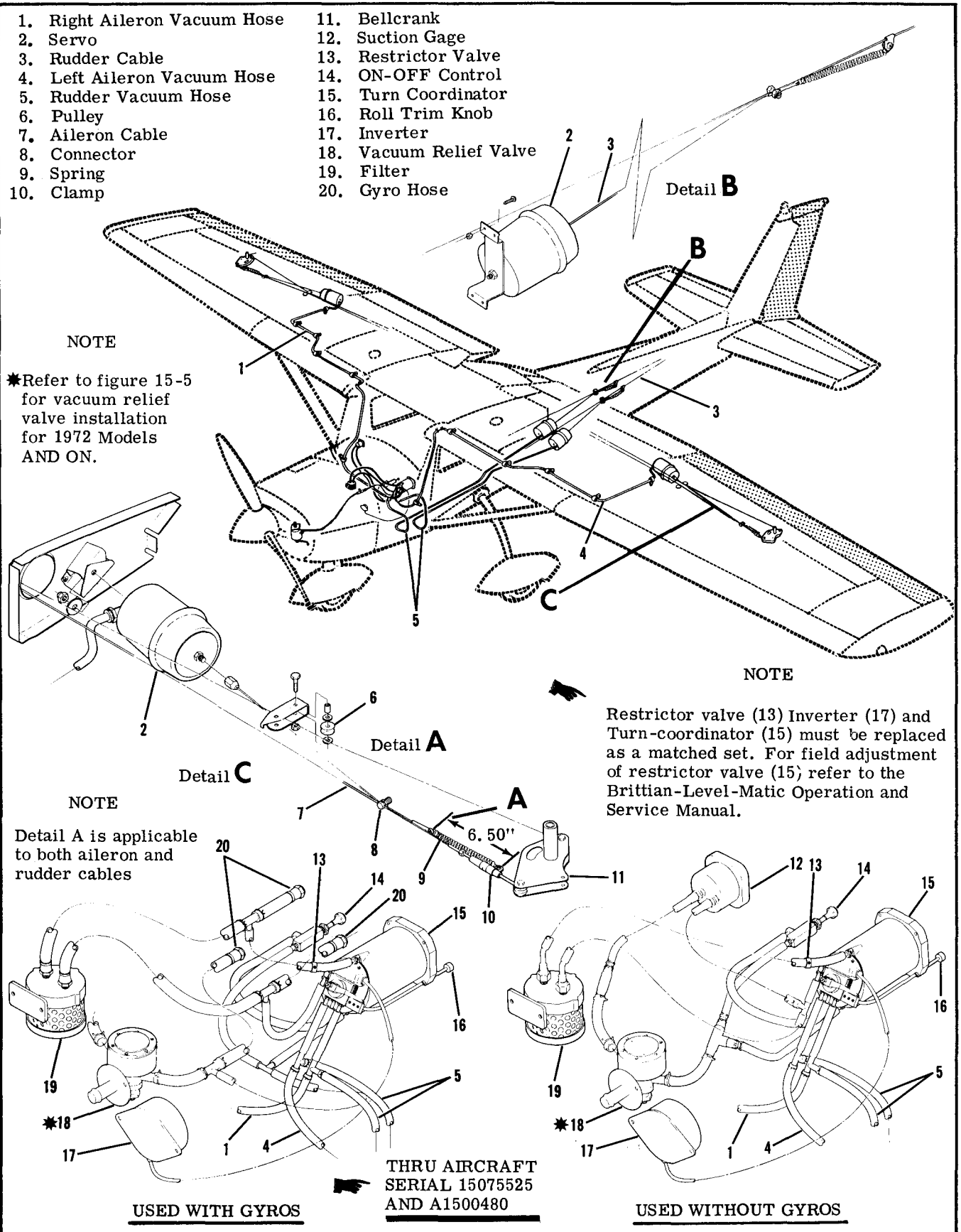

NOTE

*Refer to figure 15-5 for vacuum relief valve installation for 1972 Models AND ON.

NOTE

Restrictor valve (13) Inverter (17) and Turn-coordinator (15) must be replaced as a matched set. For field adjustment of restrictor valve (15) refer to the Brittan-Level-Matic Operation and Service Manual.

NOTE

Detail A is applicable to both aileron and rudder cables

USED WITH GYROS

THRU AIRCRAFT
SERIAL 15075525
AND A1500480

USED WITHOUT GYROS

Figure 15-8. Wing Leveler Control System

15-58. ELECTRIC CLOCK.

15-59. DESCRIPTION. The electric clock is connected to the battery through a one-ampere fuse mounted adjacent to the battery box. The clock electrical circuit is separate from the aircraft electrical system and will operate when master switch is OFF.

15-60. WING LEVELER. (Refer to figure 15-8.)
■ THRU AIRCRAFT SERIAL 15075525 AND A1500480.

15-61. DESCRIPTION. The wing leveler control system, consisting of a turn coordinator (15), pneumatic servos (2), connecting cables (3 and 7) and hose (1, 4 and 5) may be installed. The turn coordinator gyro senses changes in roll attitude, then electrically meters vacuum power from the engine-driven vacuum pump to the cylinder-piston servos, operating ailerons for longitudinal stability. In addition to aileron servos, two servos are connected to the rudder cables and provide lateral (yaw) stability that prevents excessive changes in heading in turbulent air. Manual control of system is afforded by the roll trim knob (16). Roll trim should not be used to correct faulty rigging or "wing heaviness." Manual override of sytem may be accomplished without damage to aircraft or system. The ON-OFF

valve (14) controls vacuum supply to distributor valve, but does not affect electrically operated turn coordinator gyro. Installation of wing leveler does not change vacuum relief valve (18) settings. Refer to appropriate publication issued by the manufacturer for trouble shooting procedures.

15-62. RIGGING.

- a. Loosen connector (8) and clamp (10).
- b. Move aileron to full up position.
- c. Move clamp (10) outboard until spring (9) is extended to 6.50 inches from hole in servo cable end to hole in clamp and tighten screw and nut.

NOTE

After completion of step "c", servo seal should be taut but not stretched.

- d. Move connector (8) outboard until sleeve contacts servo cable end, then back off approximately .06 inch and torque connector to 70-90 pound-inches.
- e. The rudder servos are rigged in same manner as aileron servos except hold full rudder and pull servo cable to extend the inactive servo until taut but not stretched, then secure cable. Hold opposite full rudder and rig remaining servo in similar manner.

SHOP NOTES:

SECTION 16
ELECTRICAL SYSTEMS

TABLE OF CONTENTS	Page	Description	Page
ELECTRICAL SYSTEMS	16-1	Trouble Shooting	16-13
General	16-1	Landing and Taxi Lights (Thru 1970 Models)	16-20
Electrical Power Supply System	16-1	Description	16-20
Description	16-1	Removal and Installation	16-20
Bus Bar	16-2	Landing and Taxi Light (1971 Models And On)	16-20
Description	16-2	Description	16-20
Master Switch	16-2	Removal and Installation	16-20
Ammeter	16-2	Dual Landing and Taxi Lights	16-20
Description	16-2	Description	16-20
Battery Power System	16-2	Removal and Installation	16-20
Battery	16-2	Navigation Lights	16-20
Description	16-2	Description	16-20
Trouble Shooting the Battery Power System	16-2	Removal and Installation	16-20
Removal and Installation	16-3	Anti-Collision Strobe Lights	16-20
Cleaning the Battery	16-3	Description	16-20
Adding Electrolyte or Water to Battery	16-3	Removal and Installation	16-24
Testing the Battery	16-4	Flashing Beacon Light	16-24
Charging the Battery	16-4	Description	16-24
Battery Box	16-4	Removal and Installation	16-24
Description	16-4	Instrument and Dome Lights	16-24
Removal and Installation	16-4	Description	16-24
Maintenance	16-4	Removal and Installation	16-24
Battery Contactor	16-4	Transistorized Light Dimming	16-24
Description	16-4	Description	16-24
Removal and Installation	16-6	Compass and Radio Dial Lighting	16-27
Battery Contactor Closing Circuit	16-6	Description	16-27
Ground Service Receptacle	16-6	Control Wheel Map Light	16-27
Description	16-6	Description	16-27
Removal and Installation	16-6	Removal and Installation (Thru 1970 Models)	16-27
Alternator Power System	16-6	Removal and Installation (1971 Models And On)	16-27
Description	16-6	Pitot Heater	16-27
Alternator	16-6	Description	16-27
Description	16-6	Cigar Lighter	16-27
Removal and Installation	16-6	Description	16-27
Alternator Field Circuit Protection	16-6	Emergency Locator Transmitter	16-31
Alternator Reverse Voltage Damage	16-6	Description	16-31
Over-Voltage Warning System	16-9	Operation	16-31
Description	16-9	Checkout Interval	16-31
Trouble Shooting the Alternator System	16-9	Removal and Installation of Transmitter	16-33
Voltage Regulator	16-11	Removal and Installation of Antenna	16-33
Description	16-11	Removal and Installation of Magnesium Six Cell Battery-Pack	16-33
Removal and Installation	16-13	Removal and Installation of Lithium Four Cell Battery-Pack	16-33
Aircraft Lighting System	16-13	Trouble Shooting	16-34
Description	16-13	Electrical Load Analysis Chart	16-36
Electrical Switch and Fuse Panel	16-13		

16-1. ELECTRICAL SYSTEMS.

16-2. GENERAL. This section contains service information necessary to maintain the Aircraft Electrical Power Supply System, Battery and External Power Supply System, Alternator Power System, Aircraft Lighting System, Pitot Heater, Stall Warning, Cigar Lighter and Electrical Load Analysis.

16-3. ELECTRICAL POWER SUPPLY SYSTEM.

16-4. DESCRIPTION. Electrical energy for the aircraft is supplied by a 14-volt, direct-current, single-wire, negative ground electrical system. A 12-volt battery supplies power for starting and furnishes a reserve source of power in the event of alternator failure. An engine-driven alternator is the normal source of power during flight and maintains a battery charge controlled by a voltage regulator. An external power source receptacle is offered as optional equipment to supplement the battery alternator system for starting and ground operation.

16-4A. BUS BAR.

16-4B. DESCRIPTION. Electrical power for electrical equipment and electrical installations is supplied through a bus bar. The bus bar is mounted on the lower side of the fuse holders through 15073961, A1500361, F15000903 and FA1500191. On these aircraft, Single-Engine Service Letter, SE72-34, Dated November 17, 1972 should be complied with to provide additional protection against accidental shorting. Beginning with 15073962, A1500362, F15000904 and FA1500192, the bus bar is relocated to the top of the fuse holders.

16-5. MASTER SWITCH.

16-6. DESCRIPTION. On 1969 models the operation of the battery and alternator systems is controlled by a master switch. The switch is a rocker type with double-pole, single-throw contacts. The switch, when operated, connects the battery contactor coil to ground and the alternator field circuit to the battery, activating the power systems. On 1970 models and on a new master switch is utilized. This switch is a interlocking split rocker with the battery mode on the right hand side and the alternator mode on the left

16-12. TROUBLE SHOOTING THE BATTERY POWER SYSTEM.

hand side. This arrangement allows the battery to be on the line without the alternator, however, operation of the alternator without the battery on the line is not possible. The switch is labeled "BAT" and "ALT" below the switch and is located on the left hand side of the switch panel.

16-7. AMMETER.

16-8. DESCRIPTION. The ammeter is connected between the battery and the aircraft bus. The meter indicates the amount of current flowing either to or from the battery. With a low battery and the engine operating at cruise speed the ammeter will show the full alternator output when all electrical equipment is off. When the battery is fully charged and cruise RPM is maintained with all electrical equipment off, the ammeter will show a minimum charging rate.

16-9. BATTERY POWER SYSTEM.

16-10. BATTERY.

16-11. DESCRIPTION. The battery is 12 volts and is approximately 25 ampere-hour capacity. The battery is mounted on the forward side of the firewall and is equipped with non-spill filler caps.

TROUBLE	PROBABLE CAUSE	REMEDY
BATTERY WILL NOT SUPPLY POWER TO BUS OR IS INCAPABLE OF CRANKING ENGINE.	Battery discharged.	1. Measure voltage at "BAT" terminal of battery contactor with master switch and a suitable load such as a taxi light turned on. Normal battery will indicate 11.5 volts or more. If voltage is low, proceed to step 2. If voltage is normal, proceed to step 3.
	Battery faulty.	2. Check fluid level in cells and charge battery at 20 amps for approximately 30 minutes or until the battery voltage rises to 15 volts. Check battery with a load type tester. If tester indicates a good battery, the malfunction may be assumed to be a discharged battery. If the tester indicates a faulty battery, replace the battery.
	Faulty contactor or wiring between contactor or master switch.	3. Measure voltage at master switch terminal (smallest) on contactor with master switch closed. Normal indication is zero volts. If voltage reads zero, proceed to step 4. If a voltage reading is obtained check wiring between contactor and master switch. Also check master switch.

fittings. Be sure eccentric bushings are positioned as marked.

b. Install bolts, spacers, and nuts to secure upper and lower ends of wing strut to wing and fuselage fittings.

c. Route flap and aileron cables, using guide wires. (See note in paragraph 4-4.)

d. Connect:

1. Electrical wires at wing root disconnects.

2. Fuel lines at wing root. (Refer to precautions outlined in paragraph 12-3.)

3. Pitot line (if left wing is being installed).

4. Wing leveler vacuum tube, if installed, at wing root.

e. Rig aileron system. (Section 6.)

f. Rig flap system. (Section 7.)

g. Refuel wing tank and check for leaks. (Refer to precautions outlined in paragraph 12-3.)

h. Check operation of wing tip and landing and taxi lights. (thru 1970 Models).

i. Check operation of fuel gage.

j. Install wing root fairings.

NOTE

Beginning with 1972 Models, a extruded fillet sealant (576.1 Permagum: Presstite Engineering Company) or equivalent is applied between cabin top skin and wing skin, also across top of lower strut fitting at skin cutout. Gap between windshield and wing leading edge is sealed with (Polyken 230 or Polyken 231; Kendall-Polyken Division, Tuck 92T; Technical Tape Corporation) or equivalent.

NOTE

Be sure to insert soundproofing panel in wing gap, if such a panel was installed originally, before replacing wing root fairings.

k. Install all wing inspection plates, interior panels and upholstery.

4-7. ADJUSTMENT (CORRECTING "WING-HEAVY" CONDITION. (See figure 4-1.) If considerable control wheel pressure is required to keep the wings level in normal flight, a wing-heavy condition exists.

a. Remove wing fairing strip on the wing-heavy side of the airplane.

b. Loosen nut (10) and rotate bushings (8) simultaneously until the bushings are positioned with the thick side of the eccentrics up. This will lower the trailing edge of the wing, and decrease wing-heaviness by increasing angle-of incidence of the wing.

CAUTION

Be sure to rotate the eccentric bushings simultaneously. Rotating them separately will destroy the alignment between the off-center bolt holes in the bushings, thus exerting a shearing force on the bolt, with possible damage to the hole in the wing spar.

c. Tighten nut and reinstall fairing strip.

d. Test-fly the aircraft. If the wing-heavy condition

still exists, remove fairing strip on the "lighter" wing, loosen nut and rotate bushings simultaneously until the bushings are positioned with the thick side of the eccentric down. This will raise the trailing edge of the wing, thus increasing wing-heaviness to balance heaviness in the opposite wing.

e. Tighten nut, install fairing strip, and repeat test flight.

4-8. WING STRUTS. (See figure 4-2.)

4-9. DESCRIPTION. Each wing has a single lift strut which transmits a part of the wing load to the lower portion of the fuselage. The strut consists of a streamlined tube riveted to two end fittings for attachment at the fuselage and wing.

4-10. REMOVAL AND INSTALLATION.

a. Remove screws from strut fairings and slide fairings along strut.

b. Remove fuselage and wing inspection plates at strut junction points.

c. Support wing securely, then remove nut and bolt securing strut to fuselage.

d. Remove nut, bolt, and spacer used to attach strut to wing, then remove strut from aircraft.

e. Reverse preceding steps to install strut.

4-11. REPAIR. Wing strut repair is limited to replacement of tie-downs and attaching parts. A badly dented, cracked, or deformed wing strut should be replaced.

4-12. FIN. (See figure 4-3.)

4-13. DESCRIPTION. The fin is primarily of metal construction, consisting of ribs and spars covered with skin. Fin tips are constructed of ABS or glass fiber construction. Hinge brackets at the fin rear spar attach the rudder.

4-14. REMOVAL AND INSTALLATION. A fin may be removed without first removing the rudder. However, for access and ease of handling, the rudder may be removed by following procedures outlined in Section 10.

a. Remove fairings on either side of fin.

b. Disconnect flashing beacon lead, tail navigation light lead, antennas and antenna leads, and rudder cables, if rudder has not been removed.

c. Remove bolts attaching rear fin brackets to horizontal stabilizer.

d. Remove bolts attaching front fin brackets to fuselage; remove fin.

e. Install fin by reversing preceding steps. Be sure to check and reset rudder and elevator travel if any stop bolts were removed or settings disturbed.

4-15. REPAIR. Fin repair should be accomplished in accordance with applicable instructions outlined in Section 18.

4-16. HORIZONTAL STABILIZER. (See figure 4-4.)

4-17. DESCRIPTION. The horizontal stabilizer is primarily of all-metal construction, consisting of ribs and spars covered with skin. Stabilizer tips

CAUTION

Do not add any type of "battery rejuvenator" to the electrolyte. When acid has been spilled from a battery, the acid balance may be adjusted by following instructions published by the Association of American Battery Manufacturers.

16-16. TESTING THE BATTERY. The specific gravity of the battery may be measured with a hydrometer to determine the state of battery charge. If the hydrometer reading is low, slow-charge the battery and retest. Hydrometer readings of the electrolyte must be compensated for the temperature of the electrolyte. Some hydrometers have a built-in thermometer and conversion chart. The following chart shows the battery condition for various hydrometer readings with an electrolyte temperature of 80° Fahrenheit.

BATTERY HYDROMETER READINGS	
READINGS	BATTERY CONDITION
1.280 Specific Gravity	100% Charged
1.250 Specific Gravity	75% Charged
1.220 Specific Gravity	50% Charged
1.190 Specific Gravity	25% Charged
1.160 Specific Gravity	Practically Dead

NOTE

All readings shown are for an electrolyte temperature of 80° Fahrenheit. For higher temperatures the readings will be slightly lower. For cooler temperatures the readings will be slightly higher. Some hydrometers will have a built-in temperature compensation chart and a thermometer. If this type tester is used, disregard this chart.

If a specific gravity reading indicates that the battery is not fully charged, the battery should be charged at approximately 20 amperes for 30 minutes, or until the battery voltage rises to 15 volts. After charging, a load type tester will give more meaningful results. A specific gravity check can be used after charging but the check cannot spot cells which short under load, broken connectors between plates of a cell, etc.

16-17. CHARGING THE BATTERY. When the battery is to be charged, the level of the electrolyte should be checked and adjusted by adding distilled water to cover the tops of the internal battery plates. Remove the battery from the aircraft and place in a well ventilated area for charging.

WARNING

When a battery is being charged, hydrogen and oxygen gases are generated. Accumulation of these gases can create a hazardous explosive condition. Always keep sparks and open flame away from the battery. Allow unrestricted ventilation of the battery area during charging.

The main points of consideration during a battery charge are excessive battery temperature and violent gassing. Under a reasonable rate of charge (20 amperes or less) the battery temperature should not rise over 125°F, nor should gassing be so violent that acid is blown from the vents.

16-18. BATTERY BOX.

16-19. DESCRIPTION. The battery is completely enclosed in a box which is painted with acid proof paint. The box has a vent tube which protrudes through the bottom of the aircraft allowing battery gases and spilled electrolyte to escape. The battery box is riveted to the forward side of the firewall.

16-20. REMOVAL AND INSTALLATION. (Refer to figure 16-1). The battery box is riveted to mounting brackets on the firewall. When a battery box is installed and riveted into place, all rivets and scratches inside the box should be painted with acid-proof lacquer, Part No. CES1054-381, available from the Cessna Service Parts Center.

16-21. MAINTENANCE. The battery box should be inspected and cleaned periodically. The box and cover should be cleaned with a strong solution of bicarbonate of soda (baking soda) and water. Hard deposits may be removed with a wire bursh. When all corrosive deposits have been removed from the box, flush it thoroughly with clean water.

WARNING

Do not allow acid deposits to come in contact with skin or clothing. Serious acid burns may result unless the affected area is washed immediately with soap and water. Clothing will be ruined upon contact with battery acid.

Inspect the cleaned box and cover for physical damage and for areas lacking proper acid proofing. A badly damaged or corroded box should be replaced. If the box or lid require acid proofing, paint the area with acid proof lacquer, Part No. CES1054-381, available from the Cessna Service Parts Center.

16-22. BATTERY CONTACTOR.

16-23. DESCRIPTION. The battery contactor is bolted to the side of the battery box. The contactor is a plunger type contactor which is actuated by turning the master switch on. When the master switch is off, the battery is disconnected from the electrical system. A silicon diode is used to eliminate spiking of transistorized radio equipment. The large terminal of the diode connects to the battery terminal of the battery contactor. The small terminal of the

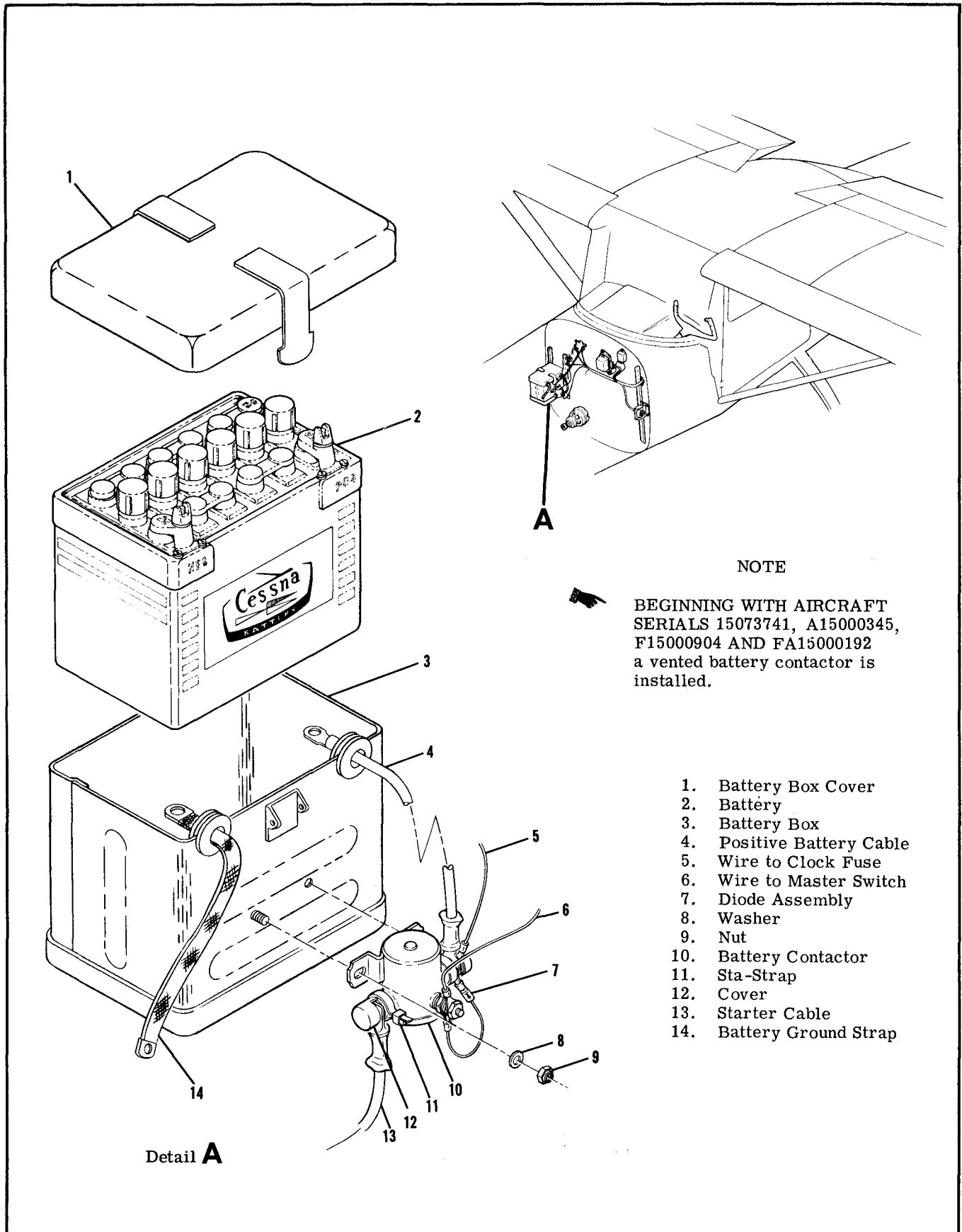

Figure 16-1. Battery, Battery Box and Battery Contactor Installations

diode and the master switch wire connect to the minus terminal of the contactor coil. A nylon cover is installed on the terminals to prevent accidental short circuits. Refer to figure 16-1.

16-24. REMOVAL AND INSTALLATION (Refer to figure 16-1).

a. Open battery box and disconnect ground cable from negative battery terminal. Pull cable clear of battery box.

b. Remove the nut, lockwasher and the two plain washers securing the battery cables to the battery contactor.

c. Remove the nut, lockwasher and the two plain washers securing the wire which is routed to the master switch.

d. Remove the bolt, washer and nut securing each side of the battery contactor to the battery box. The contactor will then be free for removal.

e. To replace the contactor, reverse this procedure.

16-25. BATTERY CONTACTOR CLOSING CIRCUIT.

This circuit consists of a 5 amp fuse, a resistor and a diode installed across the battery contactor. This serves to shunt a small charge around the battery contactor when the battery is too dead to energize the contactor by itself.

16-26. GROUND SERVICE RECEPTACLE.

16-27. DESCRIPTION. A ground service receptacle is offered as optional equipment to permit the use of external power for cold weather starting or when performing lengthy electrical maintenance.

NOTE

Before connecting an external power source, it is important that the master switch be turned "ON." This will close the battery contactor and enable the battery to absorb transient voltages which otherwise might damage the electronic equipment. It will also provide excitation of the alternator field in the event that the battery is completely dead.

16-28. REMOVAL AND INSTALLATION (Refer to figure 16-2).

a. Open battery box and disconnect the ground cable from the negative terminal of the battery and pull the cable from the battery box.

b. Remove the nuts, washers and ground strap from the studs of the receptacle and remove the battery cable.

c. Remove the screws and nuts holding the receptacle. The receptacle will then be free from the bracket.

d. To install a ground service receptacle, reverse this procedure. Be sure to place the ground strap on the negative stud of the receptacle.

16-29. ALTERNATOR POWER SYSTEM.

16-30. DESCRIPTION. The alternator system consists of an engine driven alternator, a voltage regulator mounted on the left hand side of the firewall and a circuit breaker located on the instrument panel. The system is controlled by the left hand portion of the split rocker, master switch labeled "ALT." Beginning with 1972 models an over-voltage sensor switch and red warning light labeled "HIGH VOLTAGE" are incorporated to protect the system, (refer to paragraph 16-36). The aircraft battery supplies the source of power for excitation of the alternator.

16-31. ALTERNATOR.

16-32. DESCRIPTION. The alternator is three phase, delta connected with integral silicon diode rectifiers. The alternator is rated at 14 volts at 60 amperes continuous output. The moving center part of the alternator (rotor) consists of an axial winding with radial interlocking poles which surround the winding. With excitation applied to the winding through slip rings the pole pieces assume magnetic polarity. The rotor is mounted in bearings and rotates inside the stator which contains the windings in which ac is generated. The stator windings are three-phase, delta connected and are attached to two diode plates, each of which contains three silicon diodes. The diode plates are connected to accomplish full-wave, rectification of ac. The resulting dc output is applied to the aircraft bus and sensed by the voltage regulator. The regulator controls the excitation applied to the alternator field thus controlling the output of the alternator.

16-33. REMOVAL AND INSTALLATION.

a. Ensure that master switch is off and the negative lead is disconnected from the battery.

b. Remove wiring from the alternator and label.

c. Remove screw and nut holding blast tube to support strap clamp, blast tube will then be free for removal.

d. Remove nuts and washers from alternator mounting bolts.

e. Remove alternator.

f. To replace alternator, reverse this procedure.

16-34. ALTERNATOR FIELD CIRCUIT PROTECTION. The 2-amp automatic resetting circuit breaker located in the removable electrical switch and fuse panel below the shock panel is provided to protect the alternator field circuit.

16-35. ALTERNATOR REVERSE VOLTAGE DAMAGE. The alternator is very susceptible to reverse polarity current because of the silicon diodes. The diodes, having a very high resistance to reverse current flow, are used without any cutout relay such as used on a generator system. The alternator diodes are arranged with their cathodes connected to the aircraft bus bar which is positive and no back current will flow. If the polarity of the battery is reversed, the diodes will offer no resistance to the current flow. The current rating of the diodes is exceeded and diode failure may result.

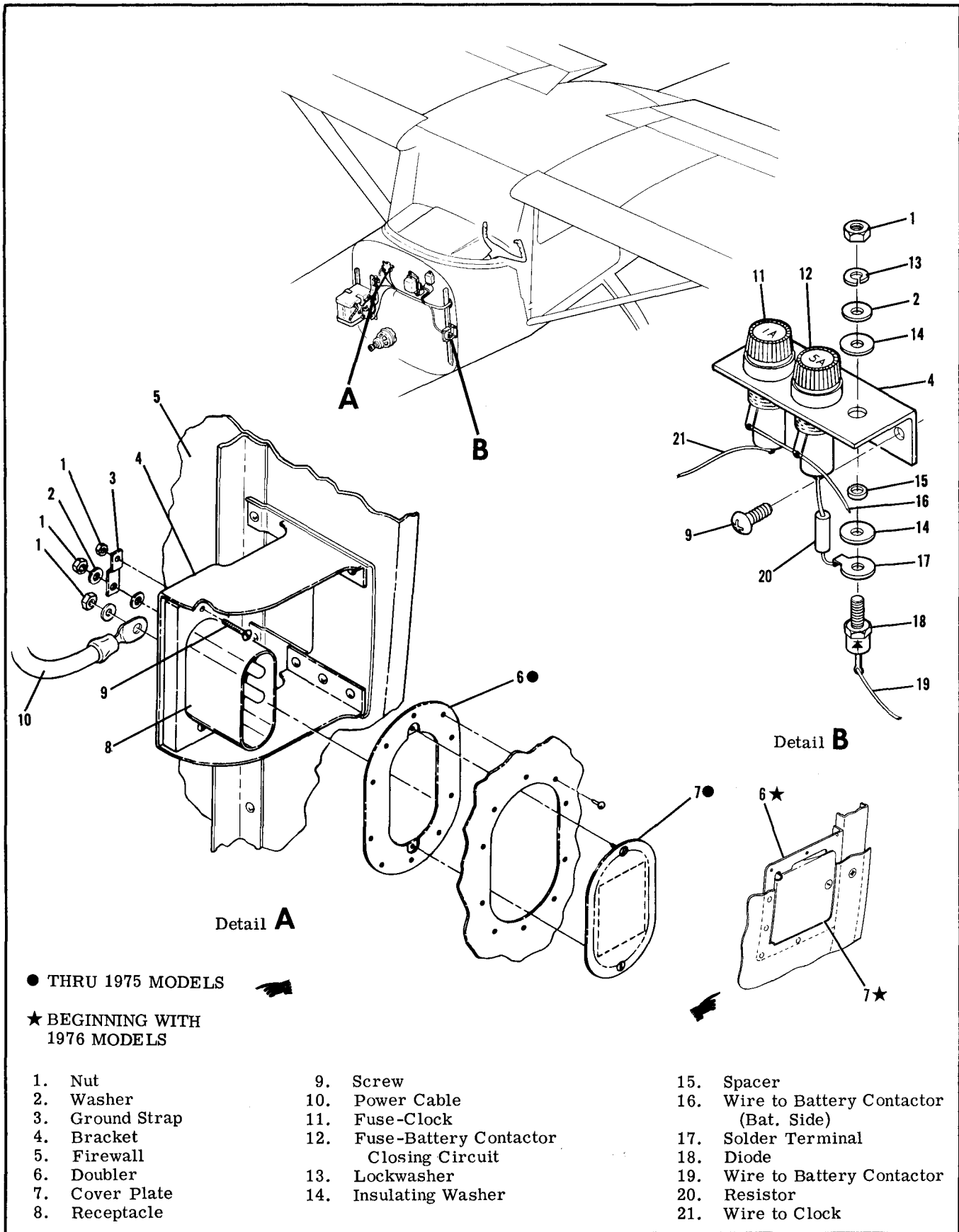
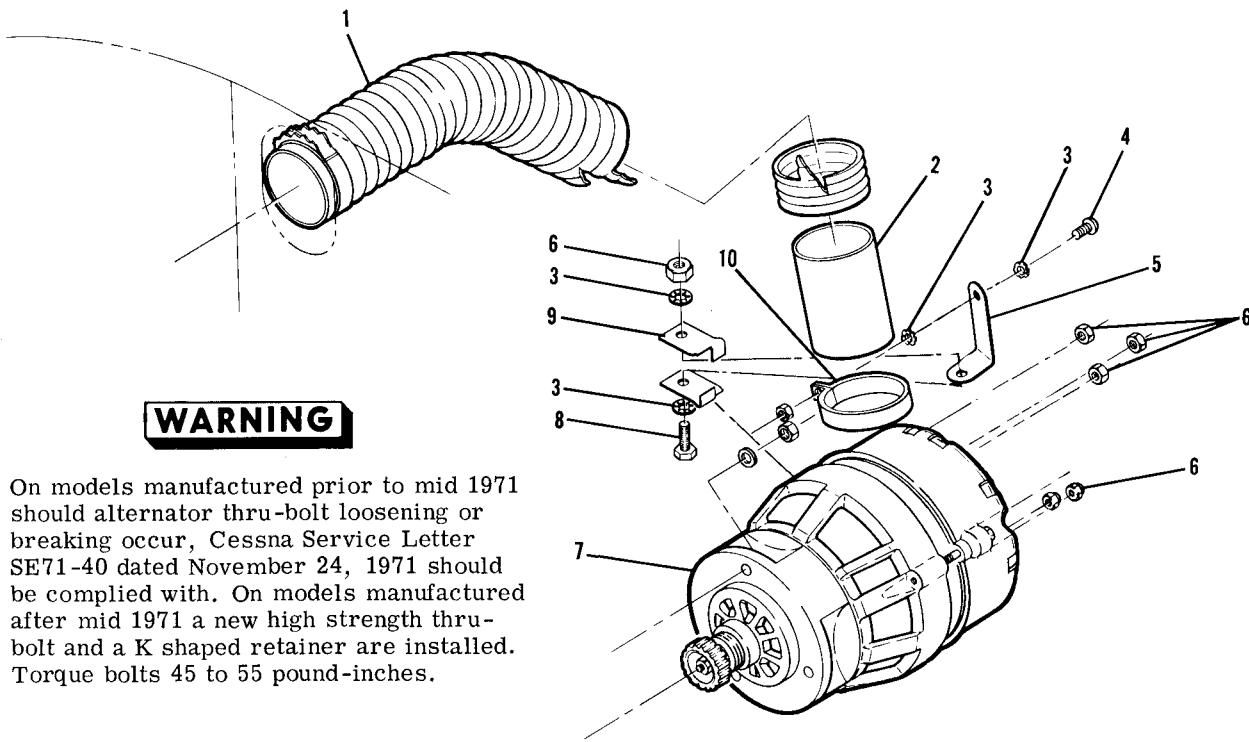
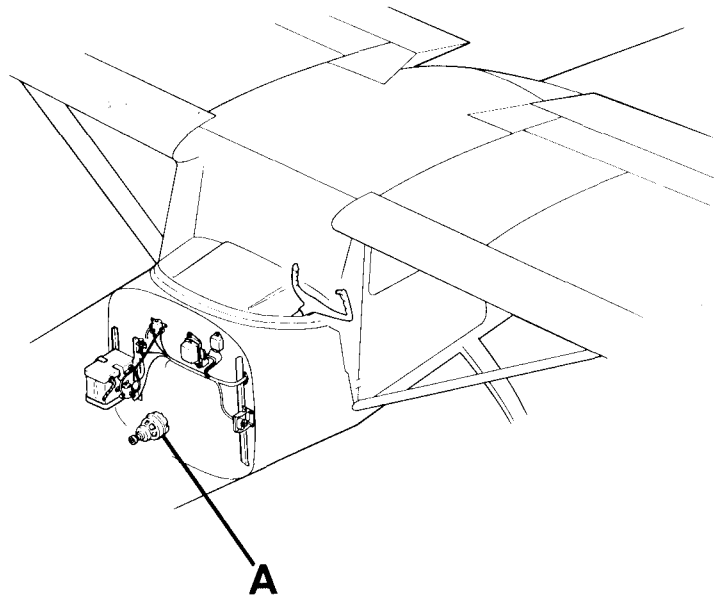

Figure 16-2. Ground Service Receptacle and Battery Contactor Closing Circuit Installations



WARNING

On models manufactured prior to mid 1971 should alternator thru-bolt loosening or breaking occur, Cessna Service Letter SE71-40 dated November 24, 1971 should be complied with. On models manufactured after mid 1971 a new high strength thru-bolt and a K shaped retainer are installed. Torque bolts 45 to 55 pound-inches.

Detail **A**

- | | | |
|-----------------------|--------------------|---------------|
| 1. Blast Tube | 4. Screw | 8. Bolt |
| 2. Blast Tube Support | 5. Support Strap | 9. Clamp Half |
| 3. Lockwasher | 6. Nut | 10. Clamp |
| | 7. Alternator Assy | |

Figure 16-3. Alternator Installation

16-36. OVER-VOLTAGE WARNING SYSTEM.

16-37. DESCRIPTION. The over-voltage system consists of an over-voltage sensor switch and a red warning light labeled "HIGH VOLTAGE". The over-voltage sensor is attached to the wire bundle behind the instrument panel and the light is located on the right hand side of the instrument panel. When an over-voltage tripoff occurs the over-voltage sensor turns off the alternator system and the red warning light comes on. The ammeter will show a discharge. Turn off both sections of the master switch to recycle the over-voltage sensor. If the over-voltage condition was transient, the normal alternator charging will resume and no further action is necessary. If the over-voltage tripoff recurs, then a generating system malfunction has occurred such that the electrical accessories must be operated from the aircraft battery only. Conservation of electrical energy must be practiced until the flight can be terminated. The over-

voltage light filament may be tested at any time by turning off the "Alternator" portion of the master switch and leaving the battery portion on. This test does not induce an over-voltage condition on the electrical system. On models prior to aircraft serial 15073084, A1500313 and F15000769, should nuisance trip-outs occur caused by voltage spiks or transient voltage, Cessna Single-engine Service Letter SE72-15 dated April 21, 1972 should be complied with.

NOTE

The over-voltage sensor switch contains solid state devices. Observe proper polarity before supplying power. Grounding the orange lead or interconnecting orange and black leads will destroy the device. When removal is required for replacement, identify (tag) wiring and follow the wiring diagram in Section 20 for rewiring.

16-38. TROUBLE SHOOTING THE ALTERNATOR SYSTEM.

TROUBLE	PROBABLE CAUSE	REMEDY
<p>AMMETER INDICATES HEAVY DISCHARGE WITH ENGINE NOT RUNNING OR ALTERNATOR CIRCUIT BREAKER OPENS WHEN MASTER SWITCH IS TURNED ON.</p>	<p>Shorted radio noise filter or shorted wire.</p>	<p>1. Remove cable from output terminal of alternator. Check resistance from end of cable to ground (MASTER SWITCH MUST BE OFF). If resistance does not indicate a direct short, proceed to step 4. If resistance indicates a direct short, proceed to step 2.</p>
		<p>2. Remove cable connections from radio noise filter. Check resistance from the filter input terminal to ground. Normal indication is infinite resistance. If reading indicates a direct short, replace filter. If no short is evident, proceed to step 3.</p>
		<p>3. Check resistance from ground to the free ends of the wires which were connected to the radio noise filter (or alternator if no noise filter is installed). Normal indication does not show a direct short. If a short exists in wires, repair or replace wiring.</p>
	<p>Shorted diodes in alternator.</p>	<p>4. Check resistance from output terminal of alternator to alternator case. Reverse leads and check again. Resistance reading may show continuity in one direction but should show an infinite reading in the other direction. If an infinite reading is not obtained in at least one direction, repair or replace alternator.</p>

16-38. TROUBLE SHOOTING THE ALTERNATOR SYSTEM (Cont).

TROUBLE	PROBABLE CAUSE	REMEDY
<p>ALTERNATOR SYSTEM WILL NOT KEEP BATTERY CHARGED.</p>	<p>Regulator faulty or improperly adjusted.</p>	<p>1. Start engine and adjust for 1500 RPM. Ammeter should indicate a heavy charge rate with all electrical equipment turned off. Rate should taper off in 1-3 minutes. A voltage check at the bus should indicate a reading consistent with the voltage vs temperature chart on page 16-10. If charge rate tapers off very quickly and voltage is normal, check battery for malfunction. If ammeter shows a low charge rate or any discharge rate, and voltage is low, proceed to step 2.</p>
		<p>2. Stop engine, remove cowl, and remove cover from voltage regulator. Turn master switch ON/OFF several times and observe field relay in regulator. Relay should open and close with master switch and small arc should be seen as contacts open. If relay is inoperative, proceed to step 3. If relay operates, proceed to step 4.</p>
		<p>3. Check voltage at "S" terminal of regulator with master switch closed. Meter should indicate bus voltage. If voltage is present, replace regulator. If voltage is not present, check wiring between regulator and bus.</p>
		<p>4. Remove plug from regulator and start engine. Momentarily jumper the "A+" and "F" terminals together on the plug. Ship's ammeter should show heavy rate of charge. If heavy charge rate is observed, replace regulator. If heavy charge rate is not observed, proceed to step 5.</p>
	<p>Faulty wiring between alternator and regulator, or faulty alternator.</p>	<p>5. Check resistance from "F" terminal of regulator to "F" terminal of alternator. Normal indication is a very low resistance. If reading indicates no, or poor continuity, repair or replace wiring from regulator to alternator.</p>

16-38. TROUBLE SHOOTING THE ALTERNATOR SYSTEM (Cont.)

TROUBLE	PROBABLE CAUSE	REMEDY
ALTERNATOR SYSTEM WILL NOT KEEP BATTERY CHARGED (Cont).	Faulty wiring between alternator and regulator, or faulty alternator (Cont).	6. Check resistance from "F" terminal of alternator to alternator case. Normal indication is 6-7 ohms. If resistance is high or low, repair or replace alternator.
		7. Check resistance from case of alternator to airframe ground. Normal indication is very low resistance. If reading indicates no, or poor continuity, repair or replace alternator ground wiring.
ALTERNATOR OVERCHARGES BATTERY - BATTERY USES EXCESSIVE WATER.	Regulator faulty or improperly adjusted.	Check bus voltage with engine running. Normal indication agrees with voltage vs temperature chart on page 16-13. Observe ship's ammeter, ammeter should indicate near zero after a few minutes of engine operation. Replace regulator.
OVER-VOLTAGE WARNING LIGHT ON.	Regulator faulty or improperly adjusted. Faulty sensor switch.	1. With engine running turn off and on battery portion of the master switch. If the light stays on shut down engine then turn on the "BAT and "ALT" portions of the master switch. Check for voltage at the "S" terminal of the voltage regulator. If voltage is present adjust or replace regulator. If voltage is not present check master switch and wiring for short or open condition. If wiring and switch are normal replace sensor.

16-39. VOLTAGE REGULATOR.

16-40. DESCRIPTION. The alternator voltage regulator contains two relays. One relay is actuated by the aircraft master switch and connects the regulator to the battery. The second relay is a two-stage, voltage sensitive device which is used to control the current applied to the field winding of the alternator. When the upper set of contacts on the voltage regulator relay are closed, full bus voltage is applied to the field. This condition will exist when the battery is being charged or when a very heavy load is applied to the system. When the upper contacts open, as the voltage begins to rise toward normal bus voltage, the voltage to the alternator field is reduced through a resistor network in the base of the regulator thus reducing the output from the alternator. As the voltage

continues to rise, assuming a very light load on the system, the lower contacts will close and ground the alternator field and shut the alternator completely off. Under lightly loaded conditions the voltage relay will vibrate between the intermediate charge rate and the lower (completely off) contacts. Under a moderate load, the relay will vibrate between the intermediate charge rate and the upper (full output) contacts. The voltage relay is temperature compensated so that the battery is supplied with the proper charging voltage for all operating temperatures. With the battery fully charged (ship's ammeter indicating at or near zero) and a moderate load applied to the system (a taxi light turned on) the voltage at the bus bar should be within the range shown according to the air temperature on the following chart:

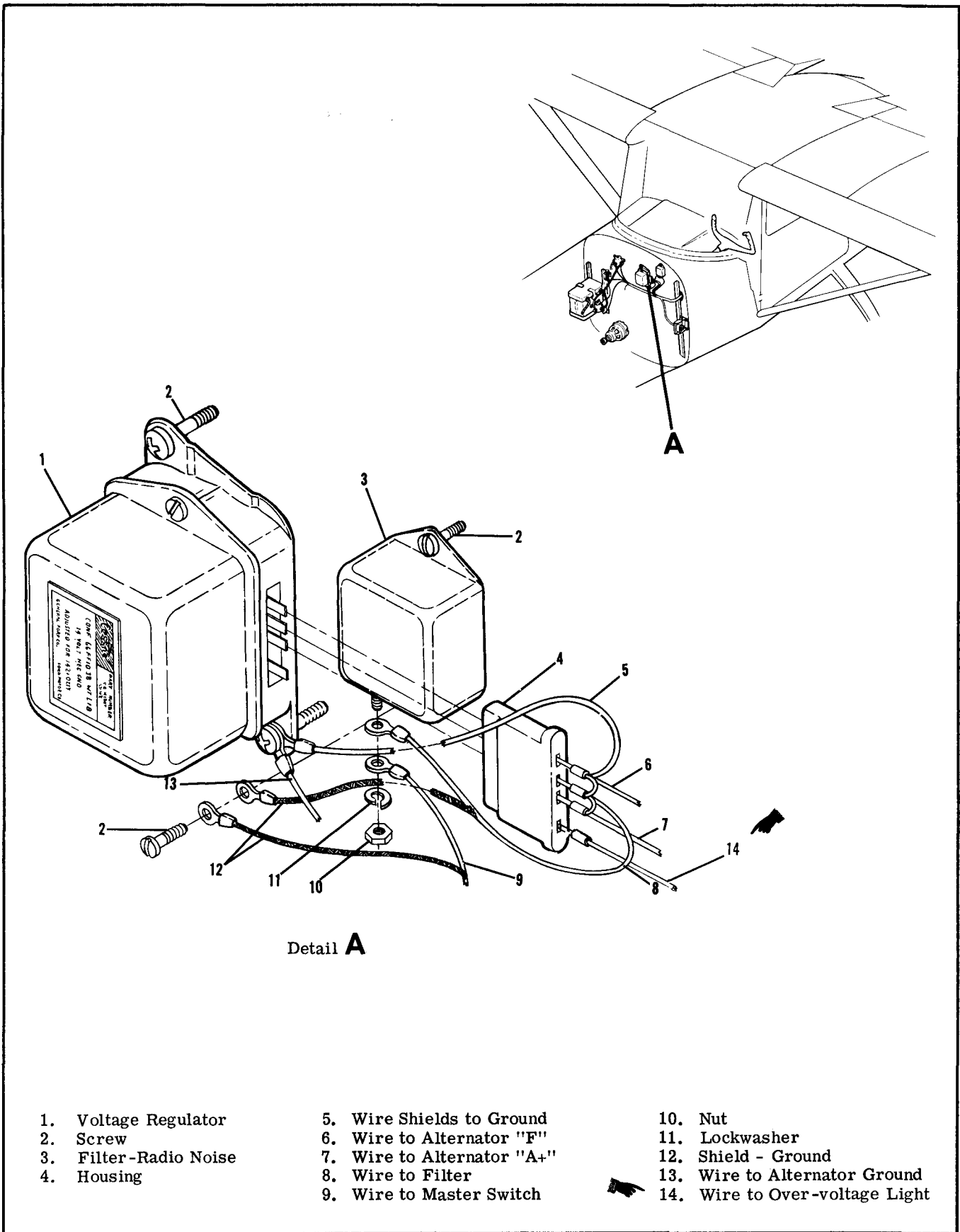

Figure 16-4. Voltage Regulator Installation

TEMPERATURE	BUS VOLTAGE
60 - 74°F	13.8 - 14.1
75 - 90°F	13.7 - 14.0
91 - 100°F	13.6 - 13.9

The voltage regulator is adjustable but adjustment on the airplane is not recommended. A bench adjustment procedure is outlined in the Cessna Alternator Charging Systems Service/Parts Manual.

16-41. REMOVAL AND INSTALLATION (Refer to figure 16-4).

- a. Make sure that the master switch is off and disconnect the negative lead from the battery.
 - b. Remove the connector plug from the regulator.
 - c. Remove two screws holding the regulator on the firewall.
 - d. To replace the regulator, reverse this procedure.
- Be sure that the connections for grounding the alternator, wiring shields and the base of the regulator are clean and bright before assembly. Otherwise,

poor voltage regulation and/or excessive radio noise may result.

16-42. AIRCRAFT LIGHTING SYSTEM.

16-43. DESCRIPTION. The aircraft lighting system consists of landing and taxi lights, navigation lights, anti-collision strobe lights, flashing beacon light, dome and instrument flood lights, control wheel map light, compass and radio dial lights.

16-44. ELECTRICAL SWITCH AND FUSE PANEL.

16-45. DESCRIPTION. Thru 1975 models a removable electrical switch and fuse panel is located below the shock panel. All electrical switches (except flap switch), fuses, radio light rheostat, circuit breaker and ignition switch are located in this panel. The complete panel unit is removable from the instrument panel by the removal of four screws. The panel unit wiring is connected to the instrument panel wire harness with quick disconnect mating connectors. New type rocker switches with spade type slip-on terminals and "push-in" plug button type mounting are introduced in this panel. Beginning with 1976 models the fuses are replaced with circuit breakers located on the lower right hand side of the instrument panel. The switch portion of the panel is no longer removable.

16-46. TROUBLE SHOOTING.

TROUBLE	PROBABLE CAUSE	REMEDY
LANDING AND TAXI LIGHT(S) OUT.	Short circuit in wiring.	1. Inspect fuse/circuit breaker. If open, proceed to step 2. If OK, proceed to step 3.
	Defective wiring.	2. Test each circuit separately until short is located. Repair or replace wiring.
	Defective switch.	3. Check voltage at lights with master and landing and taxi light switches ON. Should read battery voltage. Replace switch.
LANDING AND/OR TAXI LIGHT OUT.	Lamp burned out.	1. Test lamp with ohmmeter or new lamp. Replace lamp.
	Open circuit in wiring.	2. Test wiring for continuity. Repair or replace wiring.
FLASHING BEACON DOES NOT LIGHT.	Short circuit in wiring.	1. Inspect fuse/circuit breaker. If open, proceed to step 2. If OK, proceed to step 3.
	Defective wiring.	2. Test circuit until short is located. Repair or replace wiring.
	Lamp burned out.	3. Test lamp with ohmmeter or a new lamp. Replace lamp. If lamp is good, proceed to step 4.

16-46. TROUBLE SHOOTING (Cont).

TROUBLE	PROBABLE CAUSE	REMEDY
FLASHING BEACON DOES NOT LIGHT (Cont).	Open circuit in wiring.	4. Test circuit from lamp to flasher for continuity. If no continuity is present, repair or replace wiring. If continuity is present, proceed to step 5.
	Defective switch.	5. Check voltage at flasher with master and beacon switch on. Should read battery voltage. Replace switch. If voltage is present, proceed to step 6.
	Defective flasher.	6. Install new flasher.
FLASHING BEACON CONSTANTLY LIT.	Defective flasher.	1. Install new flasher.
ALL NAV LIGHTS OUT.	Short circuit in wiring.	1. Inspect fuse/circuit breaker. If open, proceed to step 2. If OK, proceed to step 3.
	Defective wiring.	2. Isolate and test each nav light circuit until short is located. Repair or replace wiring.
	Defective switch.	3. Check voltage at nav light with master and nav light switches on. Should read battery voltage. Replace switch.
ONE NAV LIGHT OUT.	Lamp burned out.	1. Inspect lamp. Replace lamp.
	Open circuit in wiring.	2. Test wiring for continuity. Repair or replace wiring.
ONE ANTI-COLLISION STROBE LIGHT DOES NOT LIGHT. THRU 1972 MODELS.	Flash tube burned out.	Test with new flash tube. Replace flash tube.
	Faulty wiring.	Test for continuity. Repair or replace.
	Faulty trigger head.	Test with new trigger head. Replace trigger head.
BOTH ANTI-COLLISION STROBE LIGHTS WILL NOT LIGHT. THRU 1972 MODELS.	Circuit breaker open.	Inspect. Reset.
	Faulty power supply.	Listen for whine in power supply to determine if power is operating.
	Faulty switch.	Test for continuity. Repair or replace.

16-46. TROUBLE SHOOTING (Cont).

TROUBLE	PROBABLE CAUSE	REMEDY
BOTH ANTI-COLLISION STROBE LIGHTS WILL NOT LIGHT. THRU 1972 MODELS. (Cont).	Faulty wiring.	Test for continuity. Repair or replace.
ONE ANTI-COLLISION STROBE LIGHT WILL NOT LIGHT. BEGINNING WITH 1973 MODELS.	Flash tube burned out.	Test with new tube. Replace flash tube.
	Faulty power supply.	Listen for whine in power supply to determine if power is operating.
	Faulty wiring.	Test for continuity. Repair or replace.
	Faulty trigger head.	Test with new trigger head. Replace trigger head.
BOTH ANTI-COLLISION STROBE LIGHTS WILL NOT LIGHT. BEGINNING WITH 1973 MODELS.	Circuit breaker open.	Inspect. Reset.
	Faulty switch.	Test for continuity. Repair or replace.
	Faulty wiring.	Test for continuity. Repair or replace.
DOME LIGHT TROUBLE.	Short circuit in wiring.	1. Inspect circuit breaker. If circuit breaker is open, proceed to step 2. If circuit breaker is OK, proceed to step 3.
	Defective wiring.	2. Test circuit until short is located. Repair or replace wiring.
		3. Test for open circuit. Repair or replace wiring. If no short or open circuit is found, proceed to step 4.
	Lamp burned out.	4. Test lamp with ohmmeter or new lamp. Replace lamp.
	Defective switch.	5. Check for voltage at dome light with master and dome light switch on. Should read battery voltage. Replace switch.

TROUBLE	PROBABLE CAUSE	REMEDY
<p>INSTRUMENT LIGHTS WILL NOT LIGHT.</p>	<p>Short circuit in wiring.</p>	<p>1. Inspect fuse/circuit breaker. If open, proceed to step 2. If OK, proceed to step 3.</p>
	<p>Defective wiring.</p>	<p>2. Test circuit until short is located. Repair or replace wiring.</p> <p>3. Test for open circuit. Repair or replace wiring. If no short or open circuit is found, proceed to step 4.</p>
	<p>Defective rheostat.</p>	<p>4. Check voltage at instrument light with master switch on. Should read battery voltage with rheostat turned full clockwise and voltage should decrease as rheostat is turned counterclockwise. If no voltage is present or voltage has a sudden drop before rheostat has been turned full counterclockwise, replace rheostat.</p>
	<p>Lamp burned out.</p>	<p>5. Test lamp with ohmmeter or new lamp. Replace lamp.</p>
<p>CONTROL WHEEL MAP LIGHT WILL NOT LIGHT THRU 1970 AIRCRAFT ONLY.</p>	<p>Nav light switch turned off.</p>	<p>1. Nav light switch has to be ON before map light will light.</p>
	<p>Short circuit in wiring.</p>	<p>2. Check lamp fuse on terminal board located on back of stationary panel with ohmmeter. If fuse is open, proceed to step 3. If fuse is OK, proceed to step 4.</p>
	<p>Defective wiring.</p>	<p>3. Test circuit until short is located. Repair or replace wiring.</p> <p>4. Test for open circuit. Repair or replace wiring. If a short or open circuit is not found, proceed to step 5.</p>
	<p>Defective map light assembly.</p>	<p>5. Check voltage at map light assembly with master and nav switches on. If battery voltage is present, replace map light assembly.</p>
<p>CAUTION</p> <p>Failure to observe polarity shown on wiring diagrams 11.7.0, will result in immediate failure of the transistor on the map light circuit board assembly.</p>		

16-46. TROUBLE SHOOTING (Cont).

TROUBLE	PROBABLE CAUSE	REMEDY
CONTROL WHEEL MAP LIGHT WILL NOT LIGHT 1971 AIRCRAFT & ON.	Nav light switch turned off.	1. Nav light switch has to be ON before map light will light.
	Short circuit in wiring.	2. Check lamp fuse on terminal board located on back of stationary panel with ohmmeter. If fuse is open, proceed to step 3. If fuse is OK, proceed to step 4.
	Defective wiring.	3. Test circuit until short is located. Repair or replace wiring. 4. Test for open circuit. Repair or replace wiring. If a short or open circuit is not found, proceed to step 5.
	Defective map light assembly.	5. Check voltage at map light assembly with master and nav switches on. If battery voltage is present, replace map light assembly.

SHOP NOTES:

This page intentionally left blank.

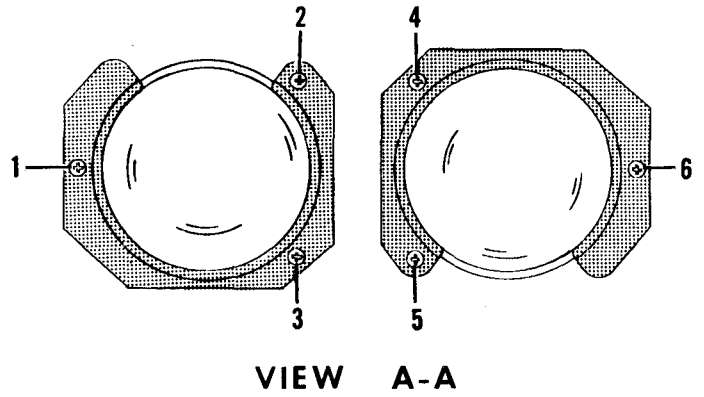
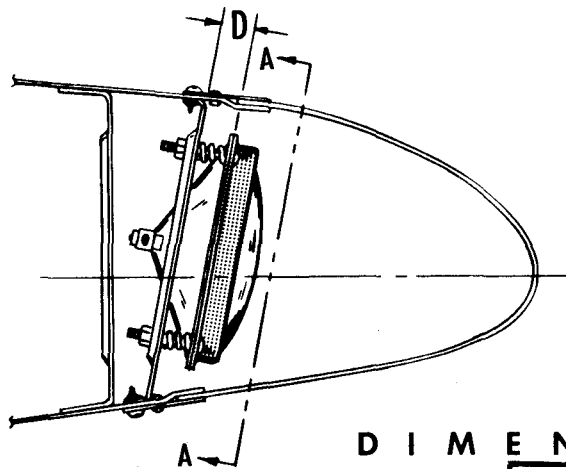

D I M E N S I O N D

NO.	150
1	0.68
2	0.50
3	0.75
4	0.50
5	0.95
6	1.18

THRU 1970 AIRCRAFT ONLY

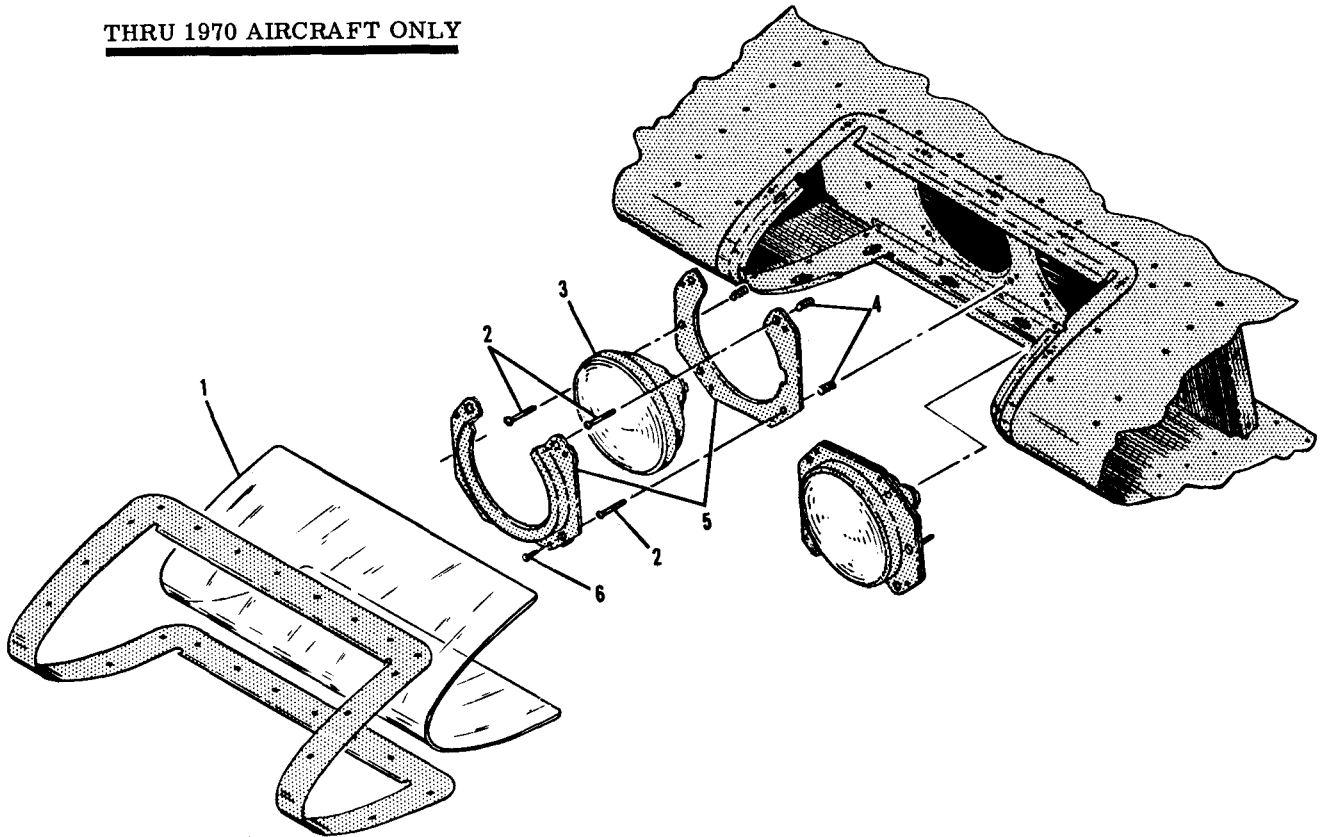

- 1. Window
- 2. Adjusting Screw

- 3. Lamp
- 4. Spring

- 5. Bracket
- 6. Screw

Figure 16-5. Landing and Taxi Light Installation and Adjustment (Sheet 1 of 5)

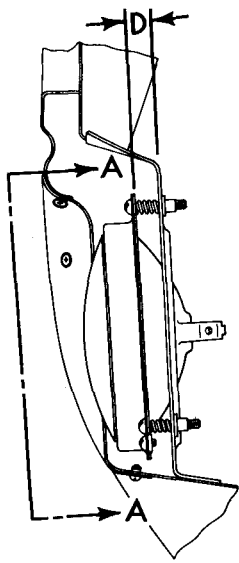

DIMENSION D

No.	150
1	.64
2	.72
3	.64

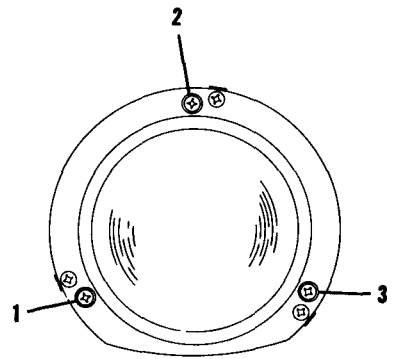

VIEW A-A

1971 AIRCRAFT ONLY

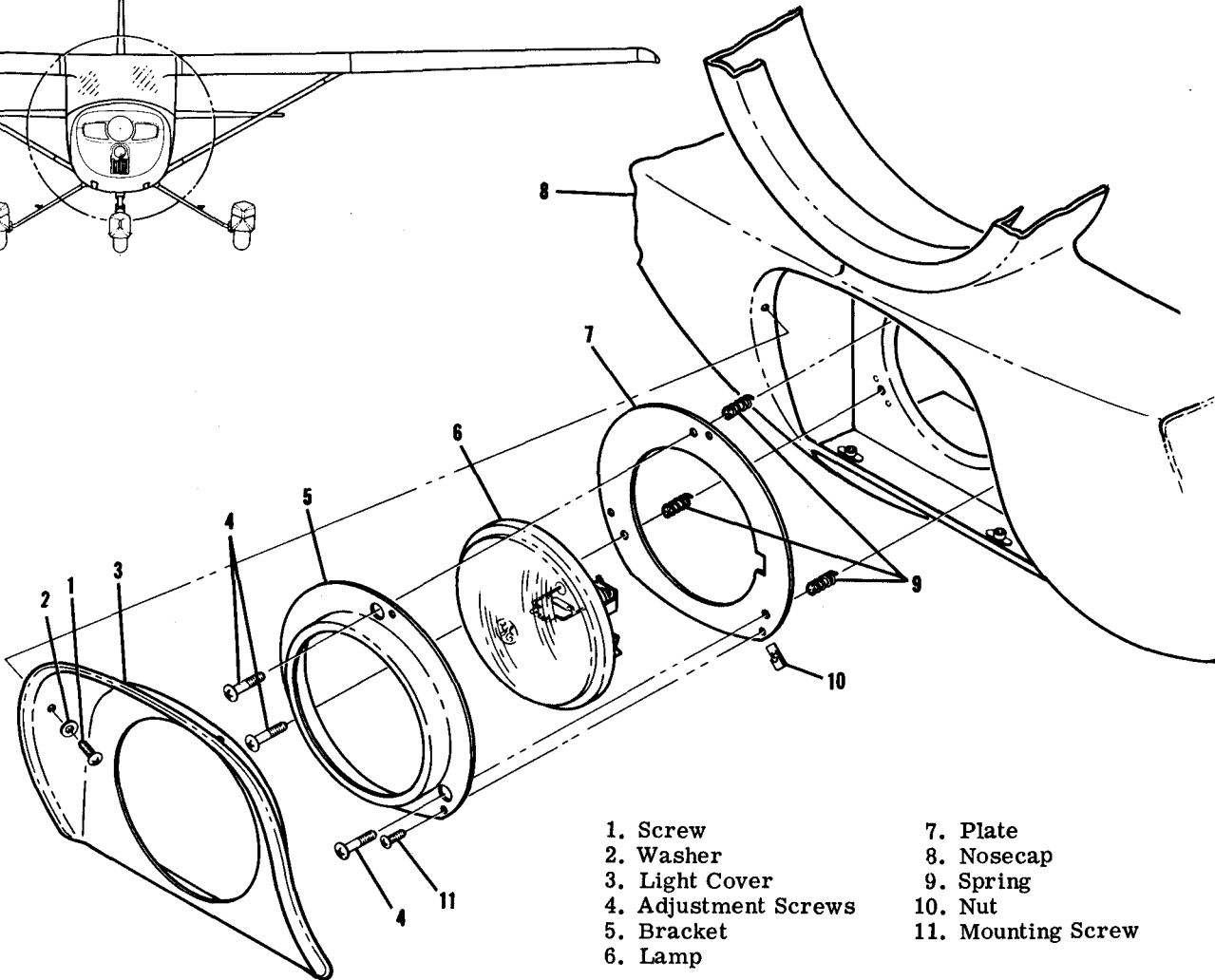
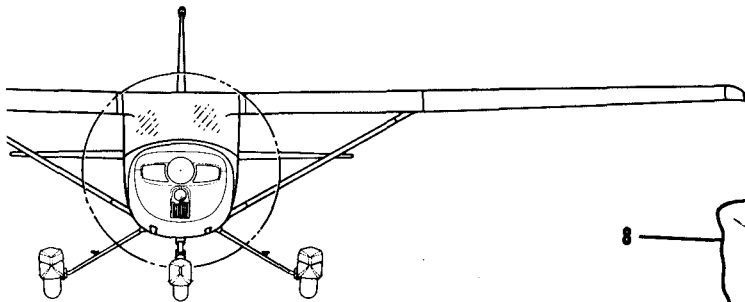

- | | |
|----------------------|--------------------|
| 1. Screw | 7. Plate |
| 2. Washer | 8. Nosecap |
| 3. Light Cover | 9. Spring |
| 4. Adjustment Screws | 10. Nut |
| 5. Bracket | 11. Mounting Screw |
| 6. Lamp | |

Figure 16-5. Landing and Taxi Light Installation and Adjustment (Sheet 2 of 5)

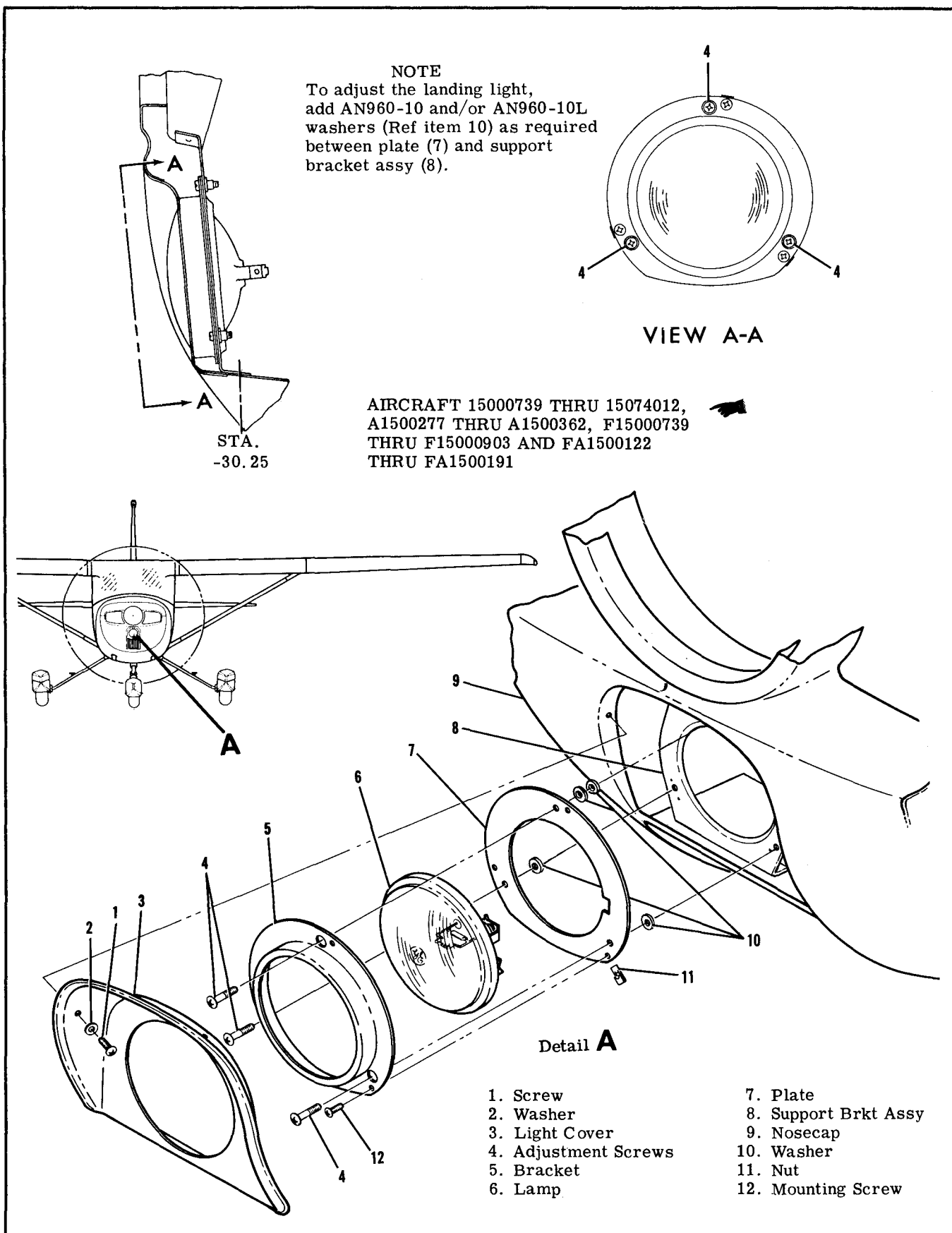
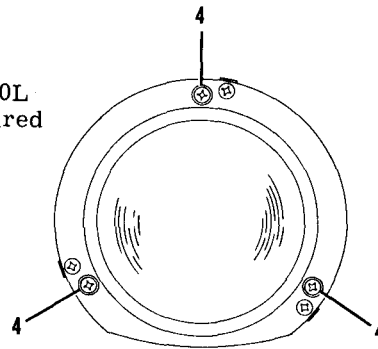
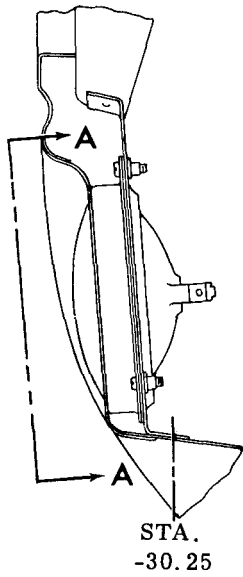
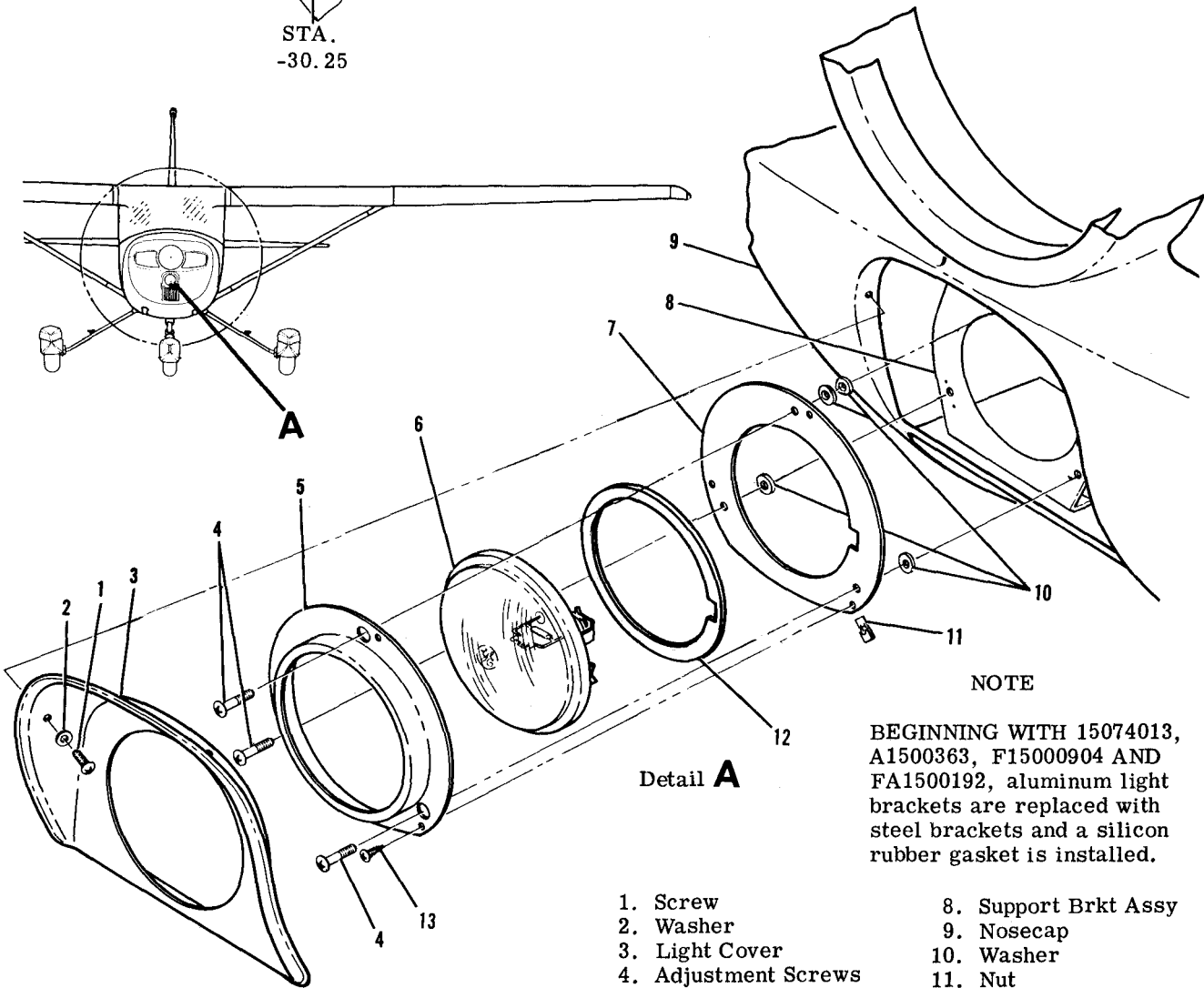

Figure 16-5. Landing and Taxi Light Installation and Adjustment (Sheet 3 of 5)

NOTE
 To adjust the landing light, add AN960-10 and/or AN960-10L washers (Ref item 10) as required between plate (7) and support bracket assy (8).



VIEW A-A



Detail A

NOTE

BEGINNING WITH 15074013, A1500363, F15000904 AND FA1500192, aluminum light brackets are replaced with steel brackets and a silicon rubber gasket is installed.

- | | |
|----------------------|----------------------|
| 1. Screw | 8. Support Brkt Assy |
| 2. Washer | 9. Nosecap |
| 3. Light Cover | 10. Washer |
| 4. Adjustment Screws | 11. Nut |
| 5. Bracket | 12. Gasket |
| 6. Lamp | 13. Mounting Screw |
| 7. Plate | |

Figure 16-5. Landing and Taxi Light Installation and Adjustment (Sheet 4 of 5)

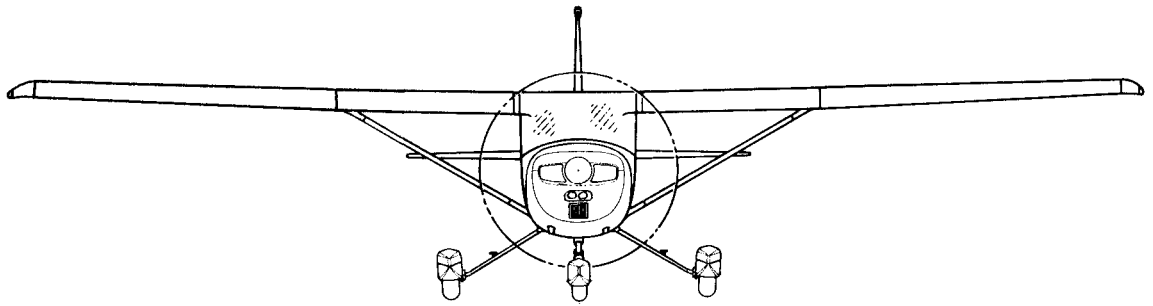

OPTIONAL BEGINNING WITH
 15074851, A1500431, F15001014
 AND FA1500212

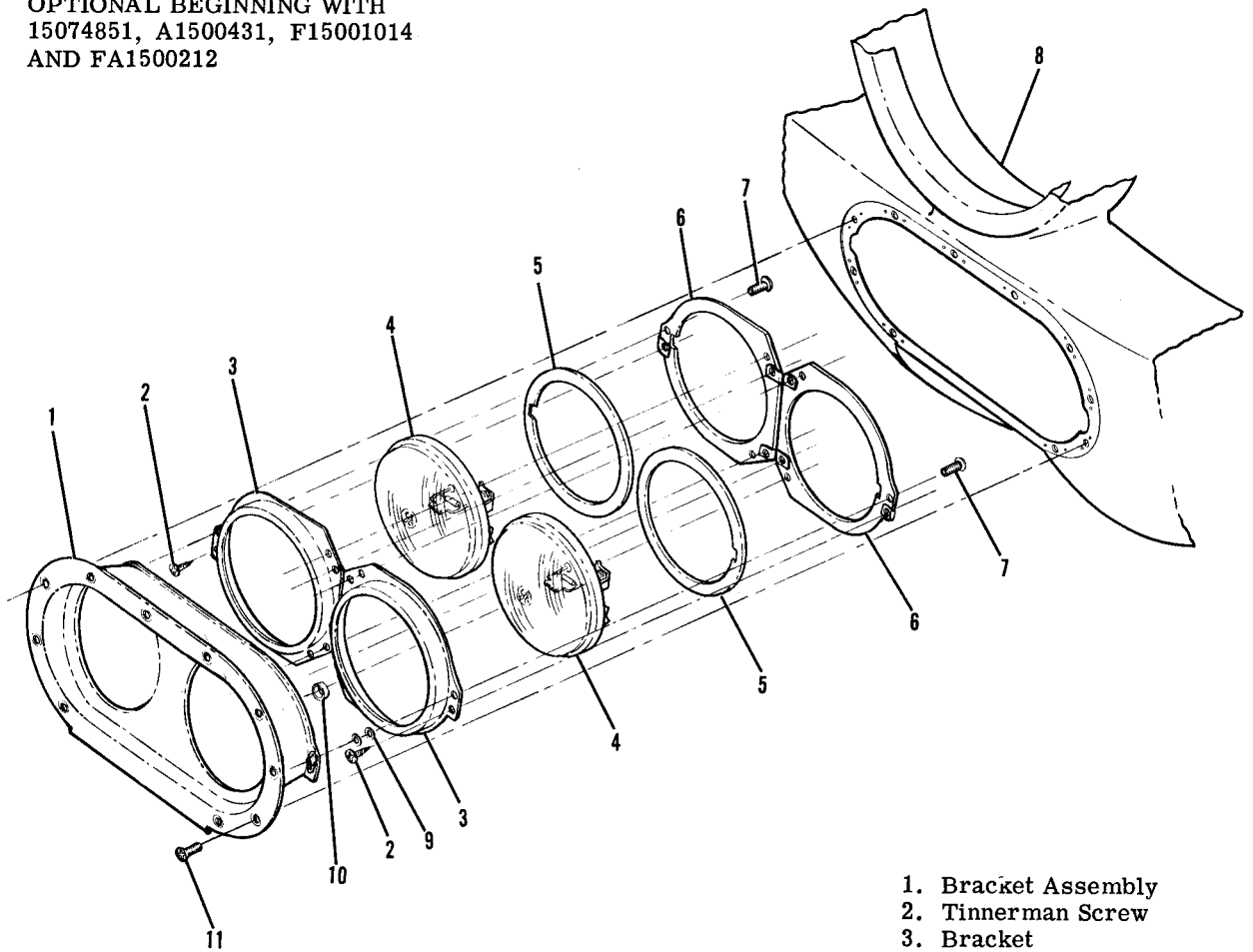

- 1. Bracket Assembly
- 2. Tinnerman Screw
- 3. Bracket
- 4. Lamp
- 5. Gasket
- 6. Plate
- 7. Adjustment Screw
- 8. Nosecap
- 9. Washer
- 10. Spacer
- 11. Mounting Screw

Figure 16-5. Landing and Taxi Light Installation and Adjustment (Sheet 5 of 5)

16-47. LANDING AND TAXI LIGHTS. (THRU 1970 MODELS)

16-48. DESCRIPTION. The landing and taxi lights are mounted in the leading edge of the left wing. A clear plastic cover provides weather protection for the lamps and is shaped to maintain the leading edge curvature of the wing. The landing light lamp is mounted on the inboard side and adjusted to throw its beam further forward than the taxi light. The landing and taxi lights are each controlled by a separate rocker type switch located on the instrument panel.

16-49. REMOVAL AND INSTALLATION. (Refer to figure 16-5).

- a. Remove the 18 screws securing the landing light window assembly (1) and the assembly will then be free for removal.
- b. Remove the four attaching screws (6) from the bracket assembly and remove the bracket.

NOTE

Do not reposition the landing and taxi light adjustment screws (2). If readjustment is required refer to figure 16-5.

- c. Remove the two screws securing the wiring to the lamp contacts and remove the lamp.
- d. Install new lamp and reassembly.

16-50. LANDING AND TAXI LIGHT (1971 MODELS AND ON.

16-51. DESCRIPTION. The landing and taxi light is mounted in the forward end of the engine cowling. This position facilitates the use of one lamp as both a landing and taxi light. A light cover provides weather protection for the lamp installation and is shaped to fit the nose cap on the engine cowling. The landing and taxi light is controlled by a rocker type switch located on the instrument panel.

16-52. REMOVAL AND INSTALLATION. Use figure 16-5 as a guide when removing or installation of this lamp.

- a. Remove the 6 screws (1) and washers (2) securing the light cover (3) to the nose cap (8). The assembly will then be free for removal.
- b. Remove the 3 attaching screws (11) from the bracket assembly and remove the bracket.

NOTE

Do not reposition the landing and taxi light adjustment screws (4) if readjustment is required refer to figure 16-5.

- c. Remove the two screws securing the wiring to the lamp contacts and remove the lamp.
- d. Install new lamp and reassemble. For reassembly reverse the above procedure.

16-52A. DUAL LANDING AND TAXI LIGHTS. (OPTIONAL BEGINNING WITH 1974 MODELS).

16-52B. DESCRIPTION. The landing and taxi lights are mounted in the lower nose cowl. The left lamp is used for taxi and the right for landing. The lamps are controlled by individual rocker type switches located on the instrument panel.

16-52C. REMOVAL AND INSTALLATION (Refer to figure 16-5).

- a. Remove screws (9) and pull landing and taxi light assembly forward from cowl.
- b. Disconnect lamp leads from lamp.
- c. Remove screws (7) from plate (6), for lamp to be replaced, and remove lamp assembly from bracket assembly (1).
- d. Remove screws (2) and disassemble lamp assembly. Remove lamp.
- e. Install new lamp and reassemble. For reassembly reverse the preceding steps.

NOTE

When removing left hand (taxi light) note position of spacer and washers for reinstallation.

16-53. NAVIGATION LIGHTS.

16-54. DESCRIPTION. The navigation lights are located on each wing tip and the top edge of the vertical fin. The lights are controlled by a rocker type switch located on the instrument panel.

16-55. REMOVAL AND INSTALLATION. For removal and installation of navigation lights refer to figure 16-6.

16-56. ANTI-COLLISION STROBE LIGHTS.

16-57. DESCRIPTION. A white strobe light is installed on each wing tip and lights are vibration resistant and operate on the principle of a capacitor

SHOP NOTES:

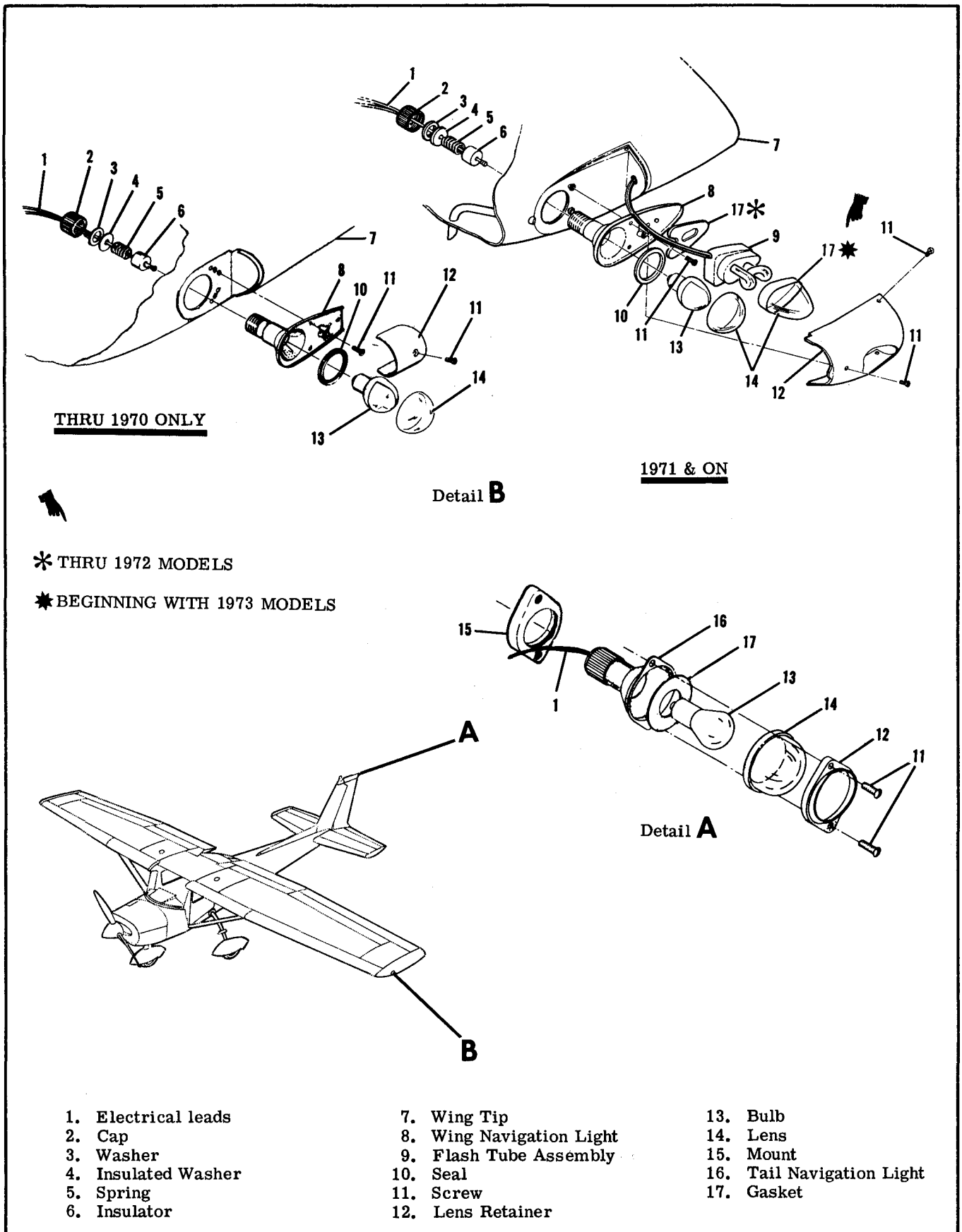
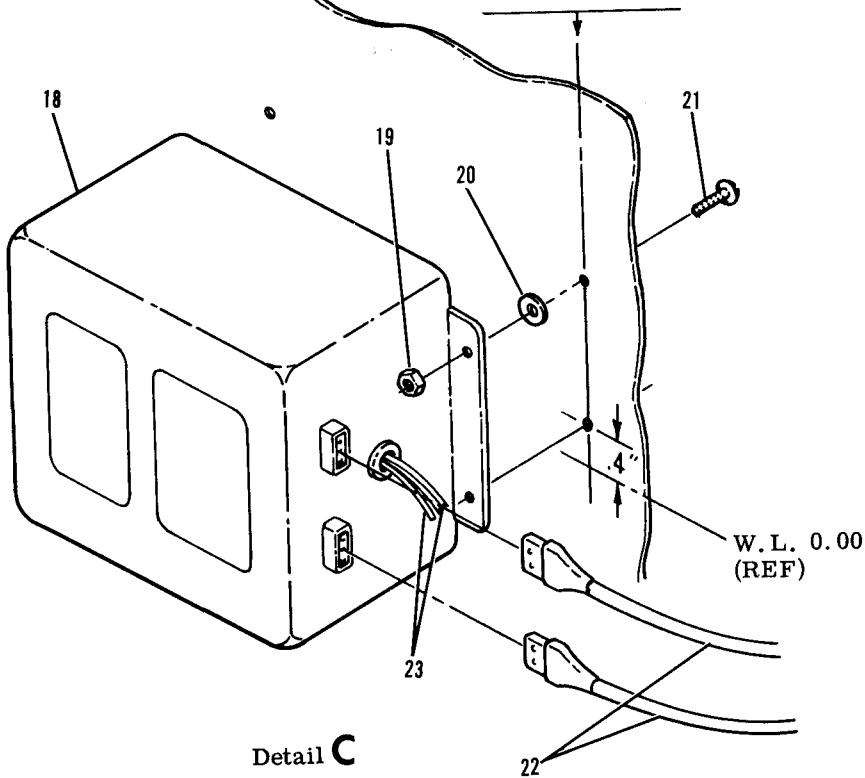
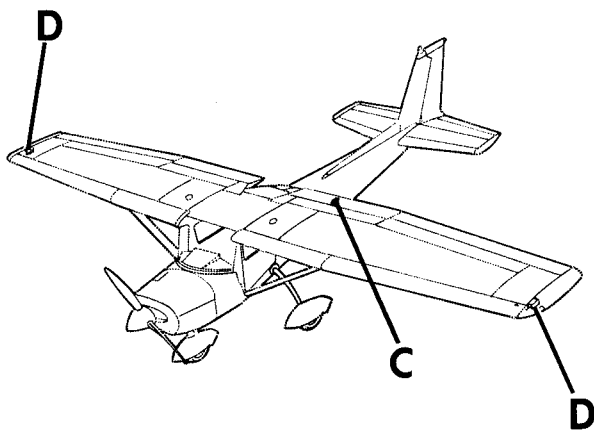

Figure 16-6. Navigation and Anti-Collision Strobe Lights Installation (Sheet 1 of 2)

STA. 98.00 THRU 1970 MODELS ONLY
 STA. 104.00 1971 MODELS AND ON



Detail C
 THRU 1972 MODELS



Detail D
 BEGINNING WITH 1973 MODELS

- 18. Power Supply
- 19. Nut
- 20. Washer
- 21. Screw
- 22. Wing Light Wires
- 23. Light Switch and Grd Wires
- 24. Wing Tip Rib

Figure 16-6. Navigation and Anti-Collision Strobe Lights Installation (Sheet 2 of 2)

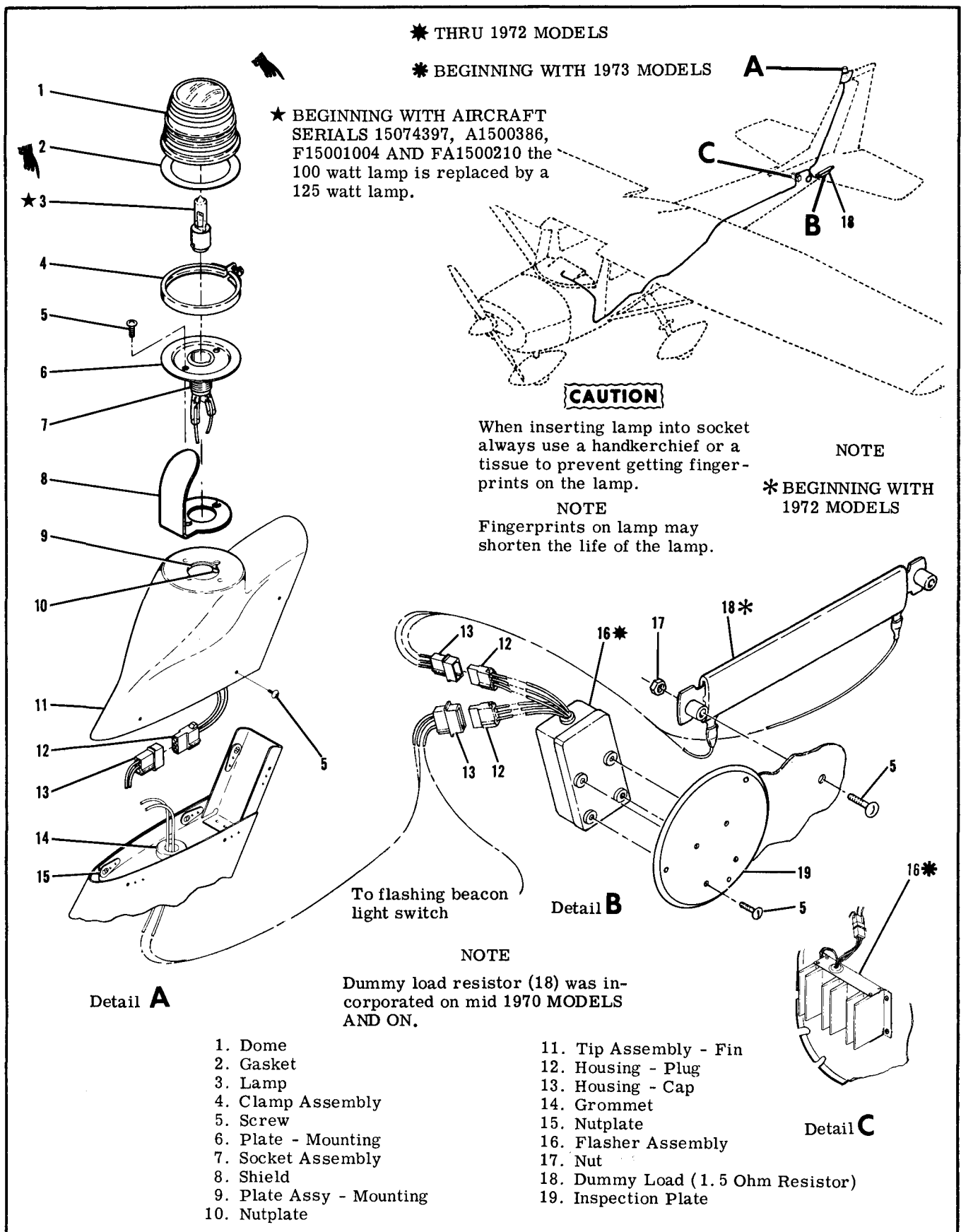

Figure 16-7. Flashing Beacon Light Installation

discharge into a xenon tube, producing an extremely high intensity flash. Thru 1972 models energy is supplied to the strobe lights from a power supply mounted just aft of the baggage curtain, on the left side of the aircraft. Beginning with 1973 models an individual power supply is mounted on each wing tip rib.

16-58. REMOVAL AND INSTALLATION. Use figure 16-6 as a guide for removal and installation of the anti-collision strobe light components.

WARNING

This anti-collision system is a high voltage device. Do not remove or touch tube assembly while in operation. Wait at least 5 minutes after turning off power before starting work.

16-59. FLASHING BEACON.

16-60. DESCRIPTION. The flashing beacon light is attached to a thermoformed plastic mounting on the vertical fin. The flashing beacon is an iodine-vapor lamp electrically switched by a solid-state flasher assembly. The flasher assembly is located in the aft section of the tailcone. The switching frequency of the flasher assembly operates the beacon at approximately 45 flashes per minute. On late 1970 models and on, a 1.5 ohm, 75 watt resistor is installed to eliminate a pulsing effect on the cabin lighting and ammeter.

16-61. REMOVAL AND INSTALLATION. For re-

moval and installation of the flashing beacon refer to figure 16-7.

16-62. INSTRUMENT AND DOME LIGHTS.

16-63. DESCRIPTION. On 1969 models the instrument and dome lights are mounted in the overhead console and provide non-glare instrument flood lighting and cabin lighting. The instrument flood light consists of a red lens and a single bulb that is controlled by a dimming rheostat mounted on the right side of the overhead console. On 1970 models and on, the instrument and dome light console has been redesigned to provide greater head clearance and is incorporated as an integral part of the Ensolite headliner. The dimming rheostat is located on the switch panel. The dome light consists of a frosted lens and a single bulb controlled by a rocker switch located on the switch panel. On 1971 models the speaker installation has been incorporated into the overhead console.

16-63A. TRANSISTORIZED LIGHT DIMMING (Refer to figure 16-8A).

16-63B. DESCRIPTION. Beginning with 1976 models a remotely located, two-circuit transistorized dimming assembly is installed to control instrument lighting. One circuit controls the compass light, map light and instrument flood light. The other circuit controls the radio lighting. A concentric knob arrangement on the instrument panel controls the system. The center portion of the knob controls the remainder of the system. Refer to figure 16-8A for removal and installation of the dimming assembly.

SHOP NOTES:

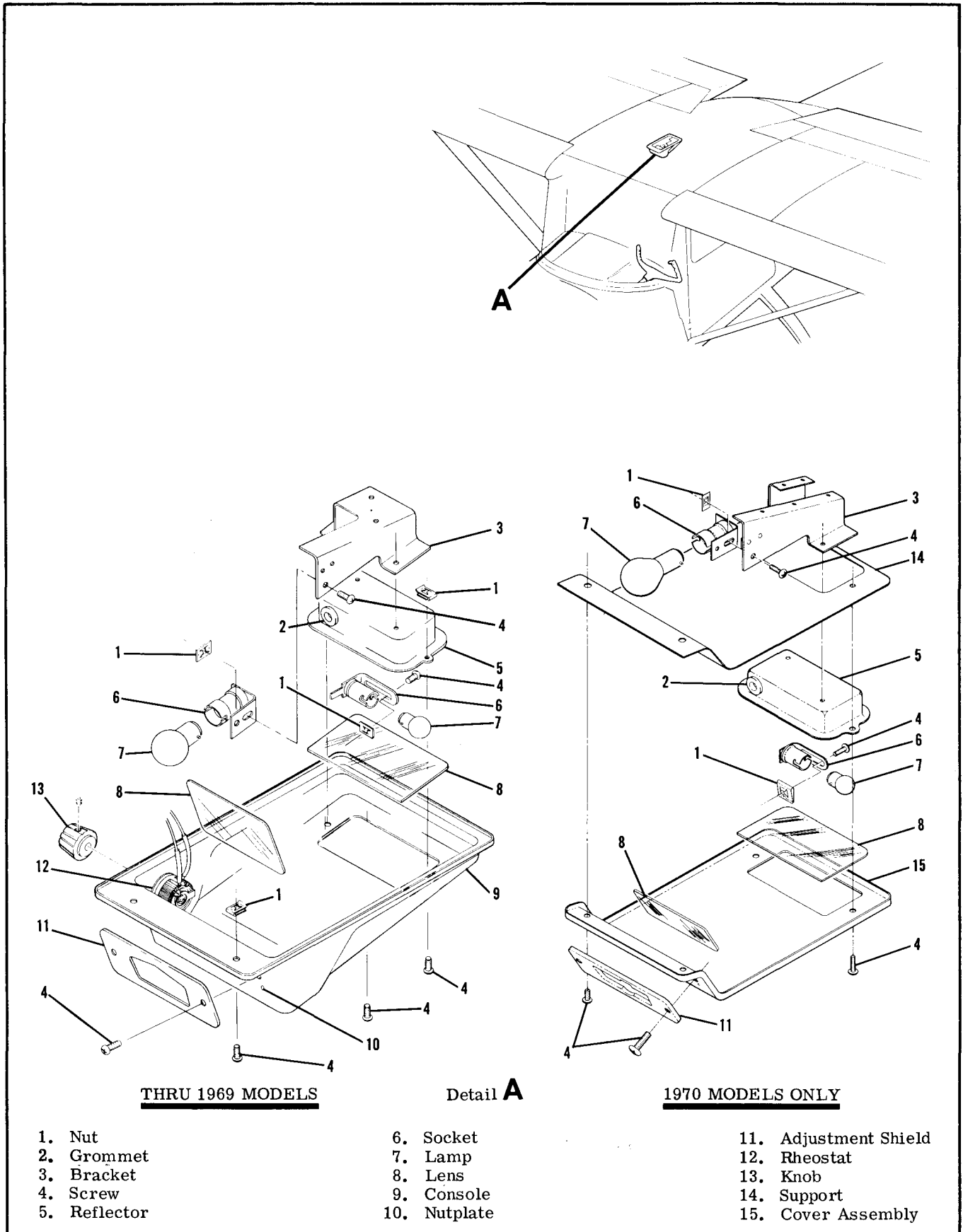
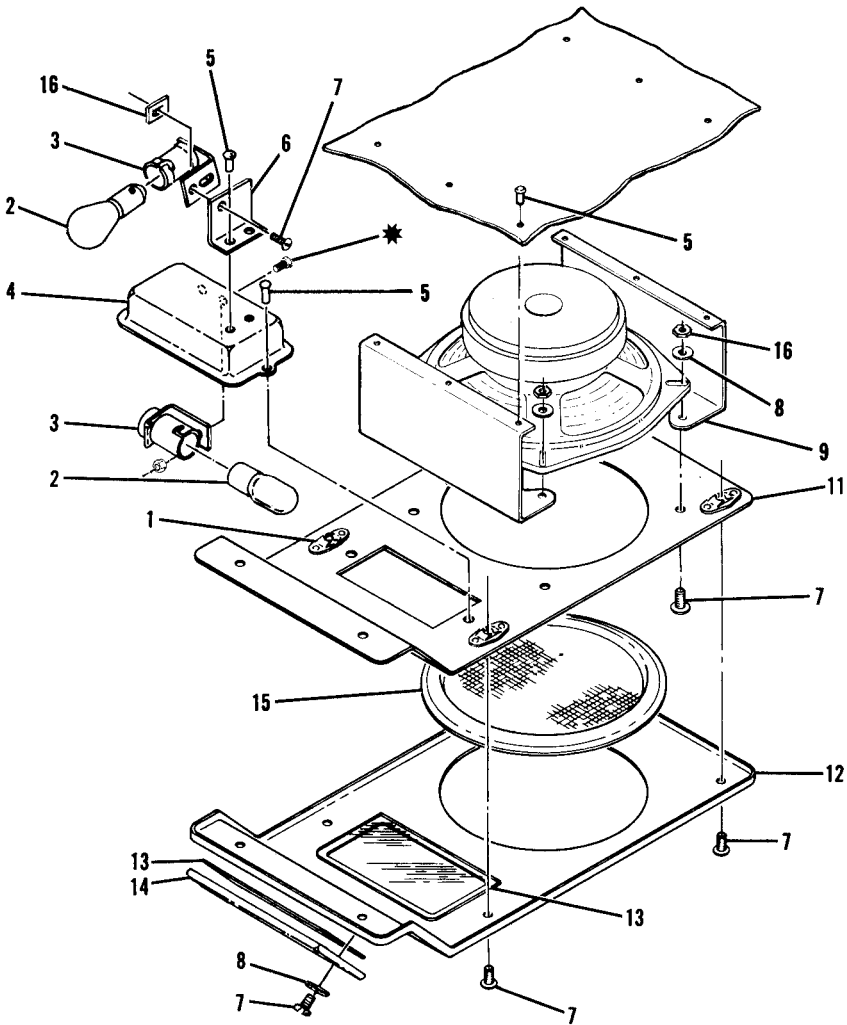
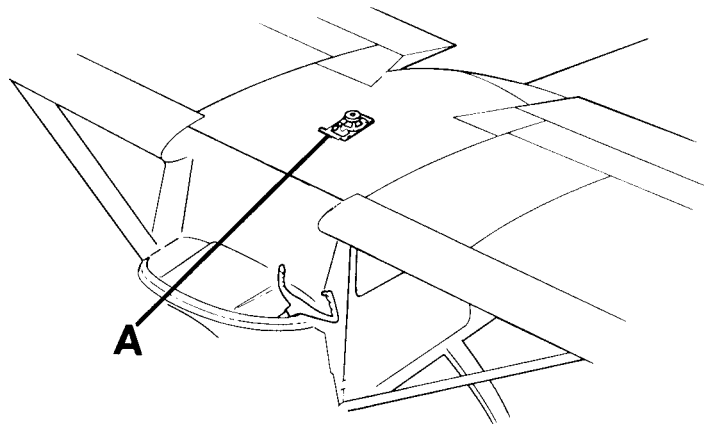

Figure 16-8. Instrument and Dome Light Console Installation (Sheet 1 of 2)

NOTE

* Screw or nut
may be installed.



1971 MODELS & ON

- 1. Nutplate
- 2. Lamp
- 3. Socket
- 4. Reflector
- 5. Rivet
- 6. Bracket
- 7. Screw
- 8. Washer
- 9. Bracket
- 10. Speaker
- 11. Plate
- 12. Cover
- 13. Lens
- 14. Adjustment Shield
- 15. Grille
- 16. Nut

Detail A

Figure 16-8. Instrument and Dome Light Console Installation (Sheet 2 of 2)

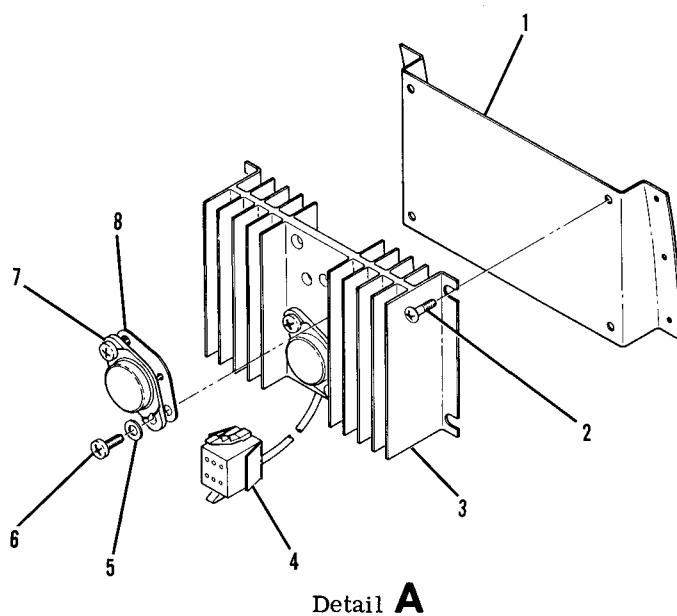
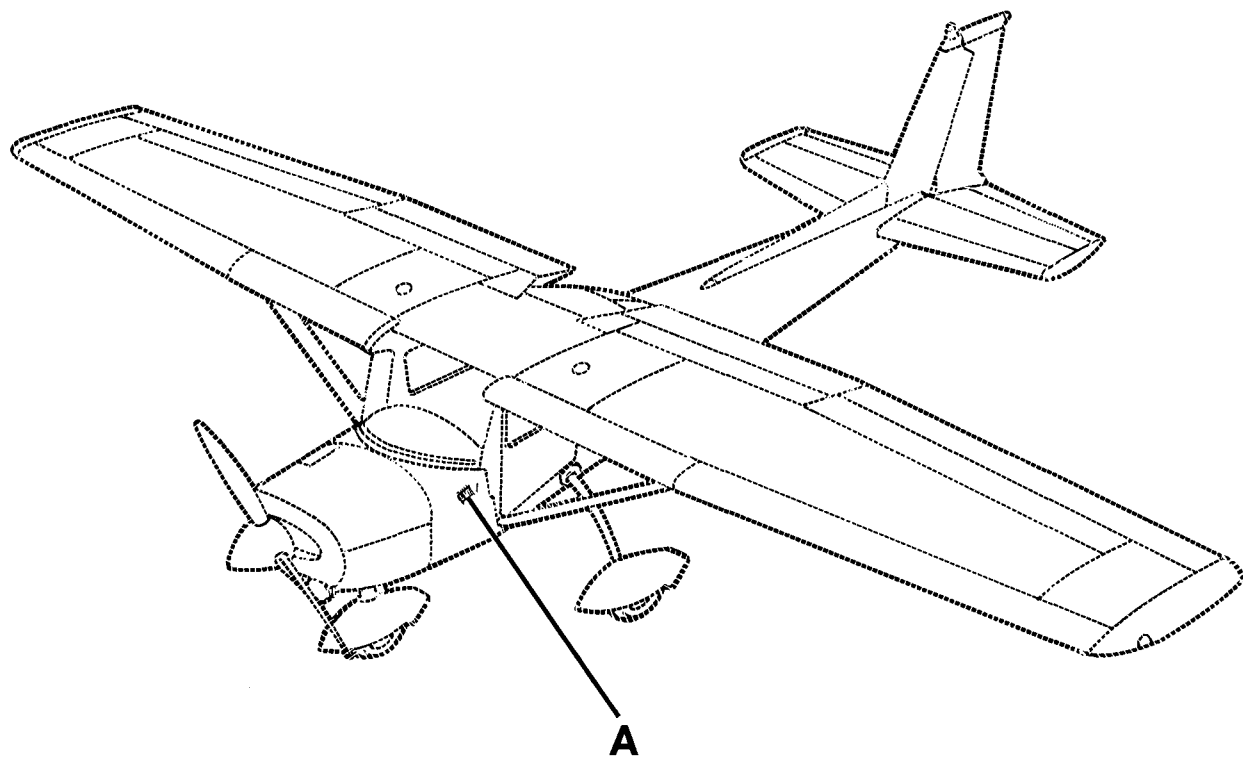

- | | |
|---------------------|---------------|
| 1. Mounting Bracket | 5. Washer |
| 2. Mounting Screw | 6. Screw |
| 3. Heat Sink | 7. Transistor |
| 4. Connector | 8. Insulator |

Figure 16-8A. Transistorized Light Dimming Installation

This page intentionally left blank.

16-64. REMOVAL AND INSTALLATION. For removal and installation of instrument and dome lights refer to figure 16-8.

16-65. COMPASS AND RADIO DIAL LIGHTING.

16-66. DESCRIPTION. The compass and radio dial lights are contained within the individual units. The compass light is controlled by the instrument light dimming rheostat located in the overhead console on the 1969 models. Beginning with 1970 models the instrument light dimming rheostat is located on the instrument panel. The radio dial lights are controlled by the radio dial light rheostat located on the instrument panel.

16-67. CONTROL WHEEL MAP LIGHT.

16-68. DESCRIPTION. An optional control wheel map light may be installed in the aircraft. The map light is mounted on the underside of the control wheel and light intensity is controlled by a thumb operated rheostat. For dimming, the rheostat should be turned clockwise.

CAUTION

Thru 1970 aircraft only, failure to observe polarity shown on wiring diagram in Section 20, will result in immediate failure of the transistor on the map light circuit board assembly.

16-69. REMOVAL AND INSTALLATION (THRU 1970 MODELS). (Refer to figure 16-9).

- a. For easy access to the map light assembly, rotate the control wheel 90°.
- b. Remove the four screws from the map light circuit board. The map light assembly will then be free for removal from the control wheel.
- c. Label the wires connecting to the map light circuit board assembly and remove the screws securing the wires to the circuit board assembly.
- d. To install the map light assembly, reverse this procedure.

16-70. REMOVAL AND INSTALLATION (1971 MODELS AND ON). (Refer to figure 16-9).

- a. For easy access to the map light assembly, rotate the control wheel 90°.
- b. Remove the screws (9), spacers (8) and shield (10) on 1972 Models and on.
- c. Remove screws (7), inserts (11) and on 1972 Models and on, shield (10).
- d. Label the map light assembly wires at the terminal block, then remove the screws securing the wires to the terminal block.
- e. For reassembly, reverse this procedure.

16-71. PITOT HEATER.

16-72. DESCRIPTION. An electrical heater unit may be installed in the pitot tube. The heater offsets the possibility of ice formation on the pitot tube. The heater is integrally mounted in the pitot tube and is operated by a rocker switch on the instrument panel. (Refer to figure 16-10).

16-73. CIGAR LIGHTER.

16-74. DESCRIPTION. Thru Aircraft Serials 15075564, F15001143, A1500480 and FA1500261 the cigar lighter (located on the instrument panel) is equipped with a thermal-actuated circuit breaker which is attached to the rear of the cigar lighter. The circuit breaker will open if the lighter becomes jammed in the socket or held in position too long. The circuit breaker may be reset by inserting a small probe into the .078 diameter hole in the back of the circuit breaker and pushing lightly until a click is heard.

CAUTION

Make sure master switch is "OFF" before inserting probe into circuit breaker on cigar lighter to reset.

Beginning with Aircraft Serials 15075565, F15001144, A1500481 and FA1500262 a 9 amp inline fuse is installed and replaces the circuit breaker to protect the wire from the cigar lighter to the ammeter.

SHOP NOTES:

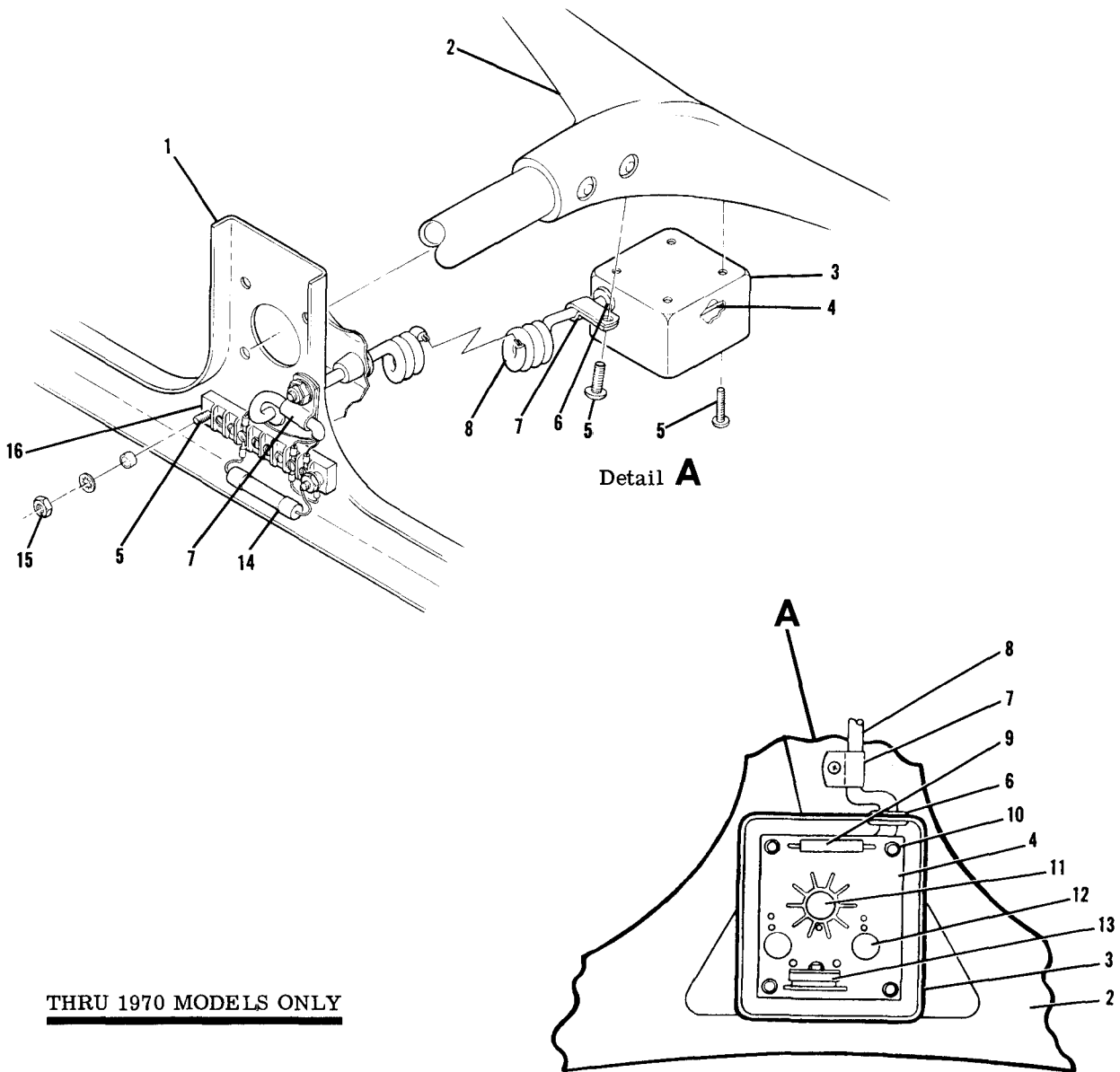

THRU 1970 MODELS ONLY

- | | | |
|------------------------------|-------------------|-----------------------------|
| 1. Stationary Panel Assembly | 6. Grommet | 12. Light |
| 2. Control Wheel Assembly | 7. Clamp | 13. Rheostat |
| 3. Shield | 8. Cable Assembly | 14. 1/2 Amp - Fuse Assembly |
| 4. Circuit Board | 9. Resistor | 15. Nut |
| 5. Screw | 10. Stand-Off | 16. Terminal Block |
| | 11. Diode | |

Figure 16-9. Control Wheel Map Light Installation (Sheet 1 of 2)

NOTE

ITEMS 5, 6, and 7 ARE USED ONLY WHEN MAP LIGHT IS NOT INSTALLED.

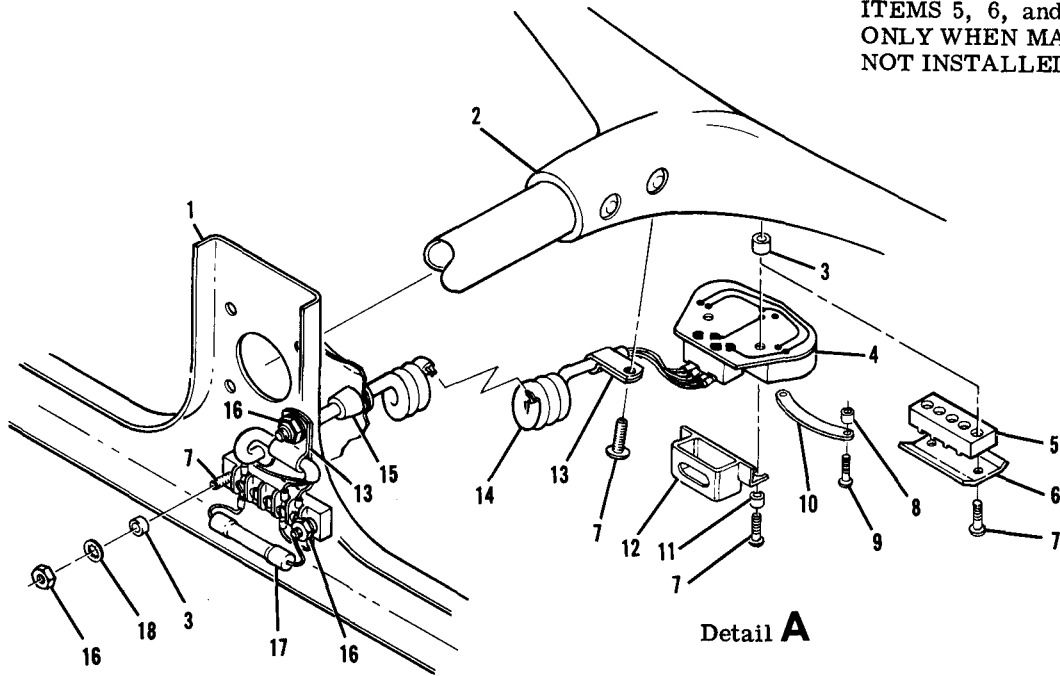

1971 MODELS & ON

1. Stationary Panel Assembly
2. Control Wheel Assembly
3. Spacer
4. Map Light Assembly
5. Terminal Block
6. Cover (1972 & ON)
7. Screw
8. Spacer (1972 & ON)
9. Screw (1972 & ON)
10. Shield (1972 & ON)
11. Insert (1972 & ON)
12. Cover (1972 & ON)
13. Clamp
14. Cable Assembly
15. Grommet
16. Nut
17. Fuse
18. Lock Washer
19. Lamp
20. Rheostat

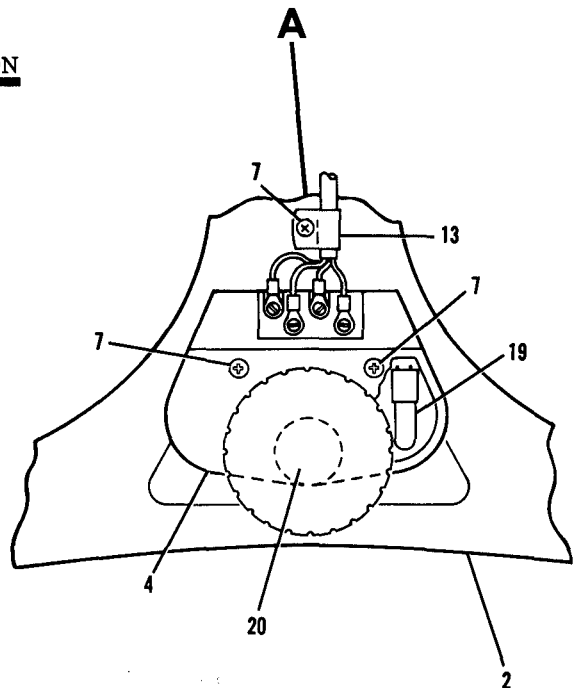
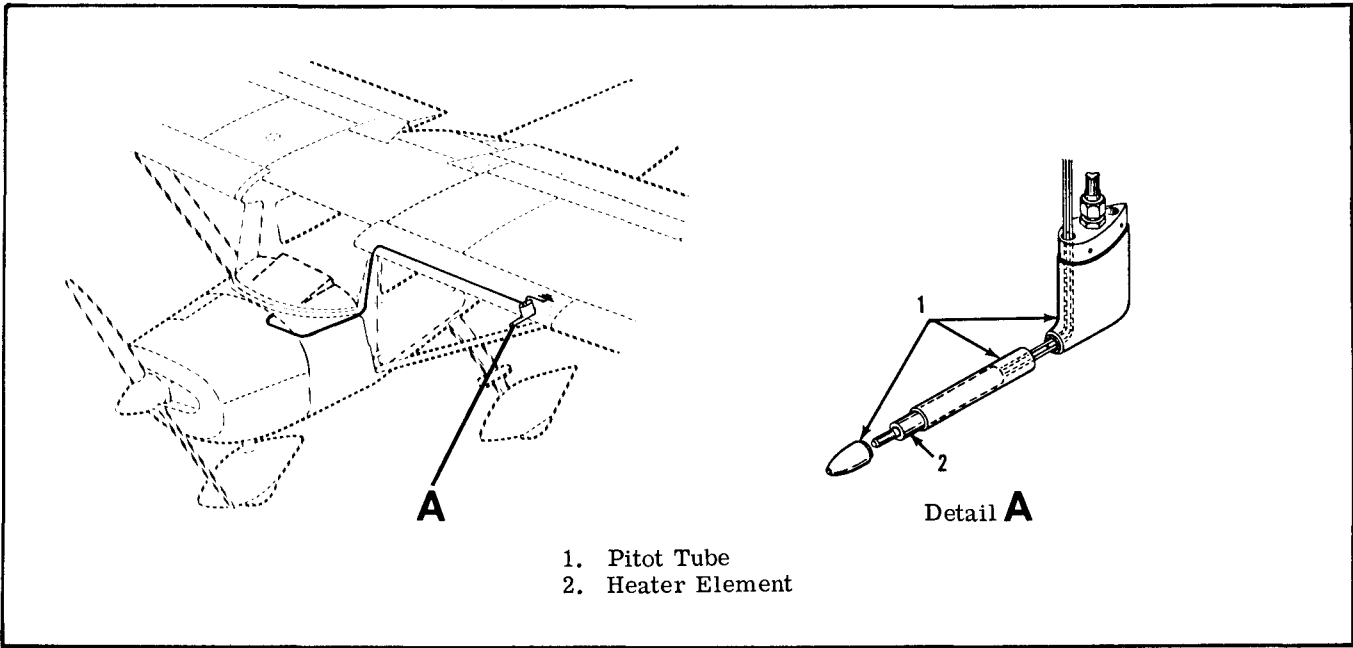

Figure 16-9. Control Wheel Map Light Installation (Sheet 2 of 2)



16-10. Pitot Heater System

SHOP NOTES:

16-75. EMERGENCY LOCATOR TRANSMITTER.

CAUTION

16-76. DESCRIPTION. The ELT is a self-contained, solid state unit, having its own power supply, with an externally mounted antenna. The C589510-0209 transmitter is designed to transmit simultaneously on dual emergency frequencies of 121.5 and 243.0 Megahertz. The C589510-0211 transmitter used for Canadian registry, operates on 121.5 only. The unit is mounted in the tailcone, aft of the baggage curtain on the right hand side. The transmitters are designed to provide a broadcast tone that is audio modulated in a swept manner over the range of 1600 to 300 Hz in a distinct, easily recognizable distress signal for reception by search and rescue personnel and others monitoring the emergency frequencies. Power is supplied to the transmitter by a battery-pack which has the service life of the batteries placarded on the batteries and also on the outside end of the transmitter. ELT's thru early 1974 models, were equipped with a battery-pack containing six magnesium "D" size dry cell batteries wired in series. (See figure 16-15) Mid 1974 thru early 1975, ELT's are equipped with a battery-pack containing four "in-line" lithium "D" size batteries wired in series. Early 1975 and on ELT's are equipped with a battery-pack containing four lithium "D" size batteries which are stacked in two's (See figure 16-16). The ELT exhibits line of sight transmission characteristics which correspond approximately to 100 miles at a search altitude of 10,000 feet. When battery inspection and replacement schedules are adhered to, the transmitter will broadcast an emergency signal at rated power (75 MW-minimum), for a continuous period of time as listed in the following table.

Do not leave the emergency locator transmitter in the ON position longer than 5 seconds or you may activate downed aircraft procedures by C. A. P., D. O. T. or F. A. A. personnel.

WARNING

Magnesium (6-cell) battery-packs (excluding 4 cell lithium battery-packs) after prolonged continuous use (1 hour) in a sealed environment give off explosive gas. If your ELT has operated for this time period or longer, as a precautionary measure, loosen the ELT cover screws, lift the cover to break air tight seal and let stand for 15 minutes before tightening screws. Keep sparks, flames and lighted cigarettes away from battery-pack.

NOTE

After relatively short periods of inactivation, the magnesium (6-cell) battery-pack develops a coating over its anode which drastically reduces self discharge and thereby gives the cell an extremely long storage life. This coating will exhibit a high resistance to the flow of electric current when the battery is first switched on. After a short while (less than 15 seconds), the battery current will completely dissolve this coating and enable the battery to operate normally. If this coating is present when your ELT is activated, there may be a few seconds delay before the transmitter reaches full power.

TRANSMITTER LIFE
TO 75 MILLIWATTS OUTPUT

Temperature	6 Cell Magnesium Battery Pack	4 Cell Lithium Battery Pack
+130°F	89 hrs	115 hrs
+ 70°F	95 hrs	115 hrs
- 4°F	49 hrs	95 hrs
- 40°F	23 hrs	70 hrs

Battery-packs have a normal shelf life of five to ten (5-10) years and must be replaced at 1/2 of normal shelf life in accordance with TSO-C91. Cessna specifies 3 years replacement of magnesium (6-cell) battery-packs and 5 years replacement of lithium (4-cell) battery packs.

16-77. OPERATION. A three position switch on the forward end of the unit controls operation. Placing the switch in the ON position will energize the unit to start transmitting emergency signals. In the OFF position, the unit is inoperative. Placing the switch in the ARM position will set the unit to start transmitting emergency signals only after the unit has received a 5g (tolerances are +2g and -0g) impact force, for a duration of 11-16 milliseconds.

16-78. CHECKOUT INTERVAL:

100 HOURS.

- Turn aircraft master switch ON.
- Turn aircraft transceiver ON and set frequency on receiver to 121.5 MHz.
- Remove the ELT's antenna cable from the ELT unit.
- Place the ELT's function selector switch in the ON position for 5 seconds or less. Immediately replace the ELT function selector switch in the ARM position after testing ELT.
- Test should be conducted only within the time period made up of the first five minutes after any hour.

CAUTION

Tests with the antenna connected should be approved and confirmed by the nearest control tower.

NOTE

Without its antenna connected, the ELT will produce sufficient signal to reach your receiver, yet it will not disturb other communications or damage output circuitry.

EMERGENCY LOCATOR TRANSMITTER
 INSTALLED AFT OF THIS PARTITION.
 MUST BE SERVICED IN ACCORDANCE
 WITH FAR PART 91.52
1205081-1

PLACARD LOCATED ON UPPER R. H.
 CORNER OF BAGGAGE CURTAIN

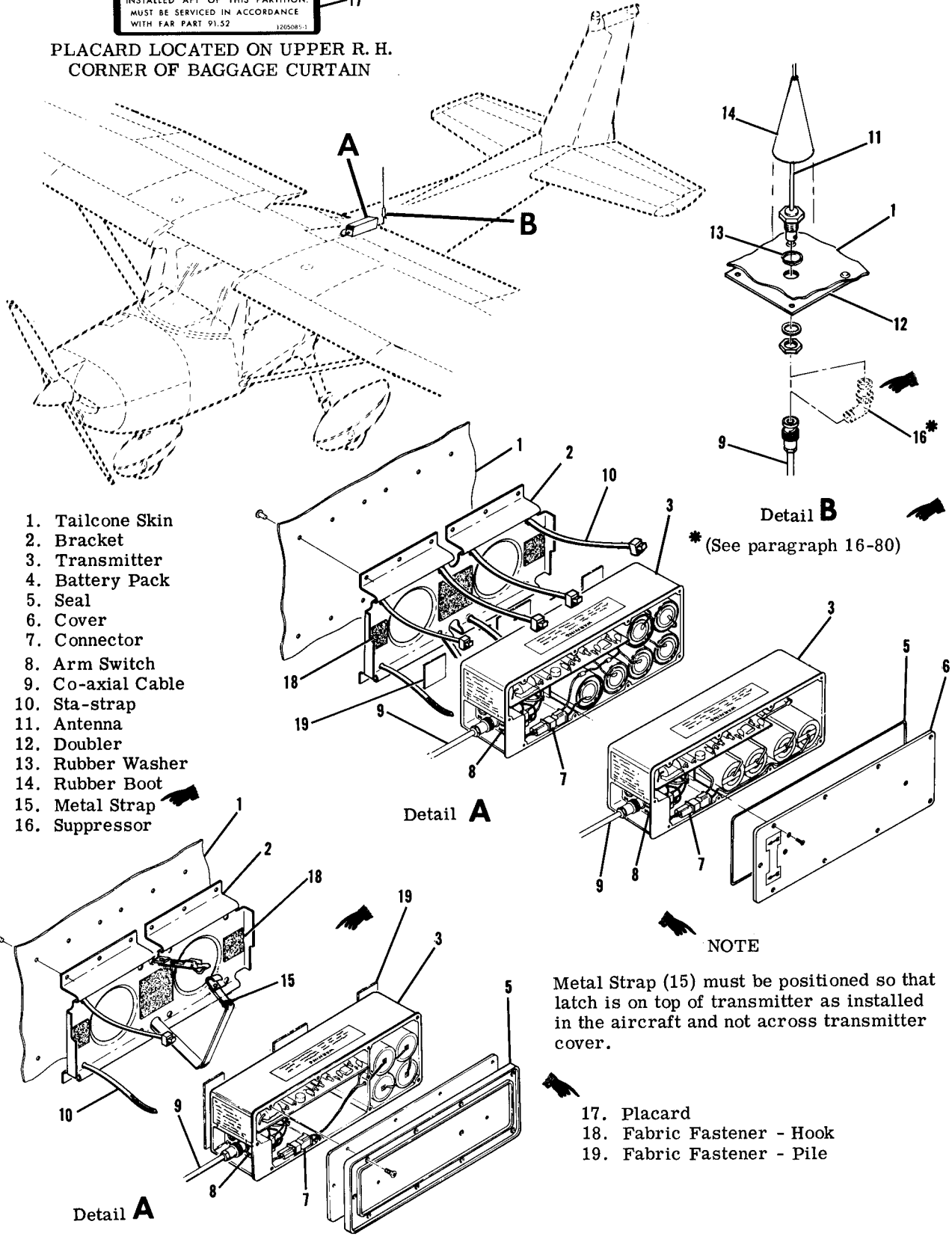

- 1. Tailcone Skin
- 2. Bracket
- 3. Transmitter
- 4. Battery Pack
- 5. Seal
- 6. Cover
- 7. Connector
- 8. Arm Switch
- 9. Co-axial Cable
- 10. Sta-strap
- 11. Antenna
- 12. Doubler
- 13. Rubber Washer
- 14. Rubber Boot
- 15. Metal Strap
- 16. Suppressor

Detail B
 *(See paragraph 16-80)

Detail A

NOTE

Metal Strap (15) must be positioned so that latch is on top of transmitter as installed in the aircraft and not across transmitter cover.

- 17. Placard
- 18. Fabric Fastener - Hook
- 19. Fabric Fastener - Pile

Figure 16-11. Emergency Locator Transmitter Installation

NOTE

After accumulated test or operation time equals 1 hour, battery-pack replacement is required.

f. Check calendar date for replacement of battery-pack. This date is supplied on a sticker attached to the outside of the ELT case and to each battery.

16-79. REMOVAL AND INSTALLATION OF TRANSMITTER. (Refer to figure 16-11.)

a. Remove baggage curtain to gain access to the transmitter and antenna.

b. Disconnect co-axial cable from end of transmitter.

c. Depending upon the particular installation, either cut four sta-straps and remove transmitter or cut sta-strap securing antenna cable and unlatch metal strap to remove transmitter.

NOTE

Transmitter is also attached to the mounting bracket by velcro strips; pull transmitter to free from mounting bracket and velcro.

NOTE

To replace velcro strips, clean surface thoroughly with clean cloth saturated in one of the following solvents: Trichloric thylene, Aliphatic Napthas, Methyl Ethyl Ketone or Enmar 6094 Lacquer Thinner. Cloth should be folded each time the surface is wiped to present a clean area and avoid redepositing of grease. Wipe surface immediately with clean dry cloth, do not allow solvent to dry on surface. Apply Velcro #40 adhesive to each surface in a thin even coat and allow to dry until quite tacky, but no longer transfers to the finger when touched (usually between 5 and 30 minutes). Porous surfaces may require two coats. Place the two surfaces in contact and press firmly together to insure intimate contact. Allow 24 hours for complete cure.

d. To reinstall transmitter, reverse preceding steps.

NOTE

An installation tool is required to properly secure sta-straps on units installed with sta-straps. This tool may be purchased locally or ordered from the Pandiut Corporation, Tinley Park, Ill., part number GS-2B (Conforms to MS90387-1).

CAUTION

Ensure that the direction of flight arrows (placarded on the transmitter) are pointing towards the nose of the aircraft.

16-80. REMOVAL AND INSTALLATION OF ANTENNA. (Refer to figure 16-11.)

- a. Disconnect co-axial cable from base of antenna.
- b. Remove the nut and lockwasher attaching the antenna base of the fuselage and the antenna will be free for removal.
- c. To reinstall the antenna, reverse the preceding steps.

NOTE

Upon reinstallation of antenna, cement rubber boot (14) using RTV102, General Electric Co. or equivalent, to antenna whip only; do not apply adhesive to fuselage skin or damage to paint may result.

CAUTION

In-service 6 cell magnesium battery-pack powered ELT's require the installation of a static electricity suppressor in the antenna cable to prevent the possibility of damage to the case of the ELT. Refer to Cessna Avionics Service Letter AV74-16 and figure 16-11.

16-81. REMOVAL AND INSTALLATION OF MAGNESIUM SIX (6) CELL BATTERY-PACK. (Refer to figure 16-12.)

NOTE

Since replacement 6 cell magnesium battery-packs are no longer available, when in-service units require replacement, use the 4 cell lithium battery-pack. Refer to paragraph 16-82.

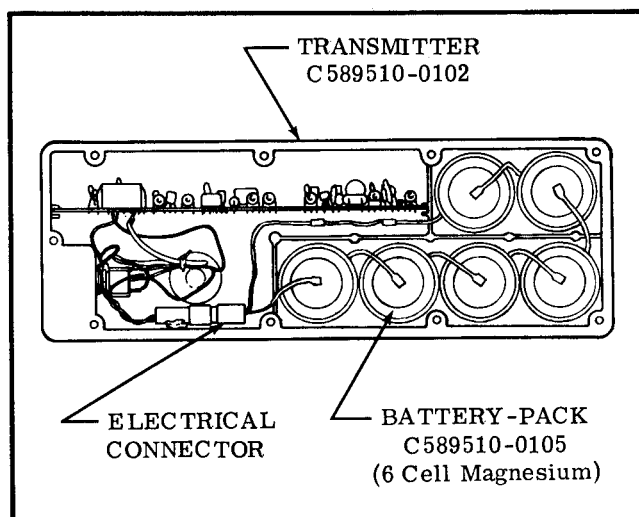

Figure 16-12. Magnesium 6 Cell Battery-Pack Installation

16-82. REMOVAL AND INSTALLATION OF LITHIUM FOUR (4) CELL BATTERY-PACK. (Refer to figure 16-13.)

NOTE

Transmitters equipped with the 4 cell battery-pack can only be replaced with another 4 cell battery-pack.

- a. After the transmitter has been removed from aircraft in accordance with para. 16-79, place the transmitter switch in the OFF position.
- b. Remove the nine screws attaching the cover to the case and then remove the cover to gain access to the battery-pack.

NOTE

Retain the rubber "O" ring gasket, rubber washers and screws for reinstallation.

- c. Disconnect the battery-pack electrical connector and remove battery-pack.
- d. Place new battery-pack in the transmitter with four batteries as shown in the case in figure 16-13.
- e. Connect the electrical connector as shown in figure 16-13.

NOTE

Before installing the new 4 cell battery-pack, check to ensure that its voltage is 11.2 volts or greater.

CAUTION

If it is desirable to replace adhesive material on the 4 cell battery-pack, use only 3M Jet Melt Adhesive #3738. Do not use other adhesive materials since other materials may corrode the printed circuit board assembly.

- f. Replace the transmitter cover by positioning the rubber "O" ring gasket, if installed, on the cover and pressing the cover and case together. Attach cover with nine screws and rubber washers.
- g. Remove the old battery-pack placard from the end of transmitter and replace with new battery-pack placard supplied with the new battery-pack.

CAUTION

Be sure to enter the new battery-pack expiration date in the aircraft records. It is also recommended this date be placed in your ELT Owner's Manual for quick reference.

SHOP NOTES:

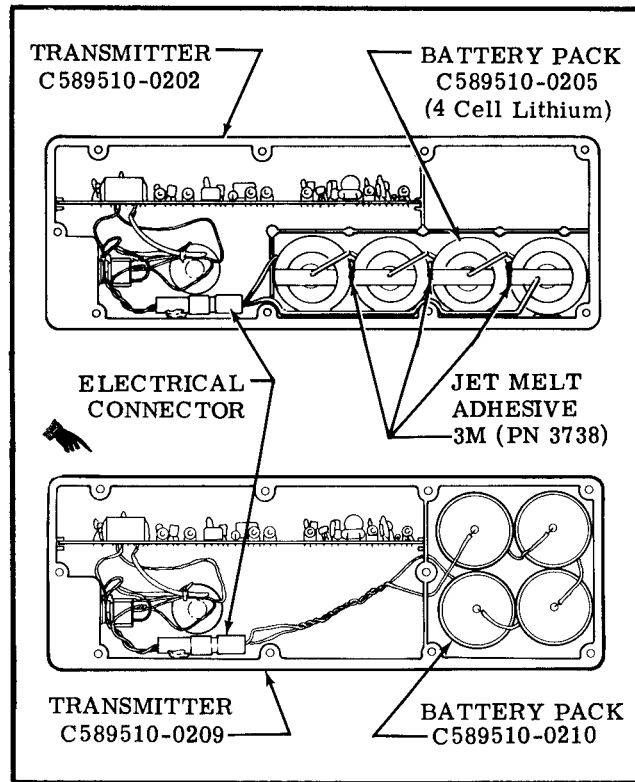

Figure 16-13. Lithium 4 Cell Battery Pack Installations

16-83. TROUBLE SHOOTING. Should your Emergency Locating Transmitter fail the 100 Hours performance checks, it is possible to a limited degree to isolate the fault to a particular area of the equipment. In performing the following trouble shooting procedures to test peak effective radiated power, you will be able to determine if battery replacement is necessary or if your unit should be returned to your dealer for repair.

TROUBLE	PROBABLE CAUSE	REMEDY
*POWER LOW	Low battery voltage.	1. Set toggle switch to off. 2. Remove plastic plug from the remote jack and by means of a Switchcraft #750 jackplug, connect a Simpson 260 model voltmeter and measure voltage. If the battery-pack voltage on the 6-cell magnesium battery pack transmitter is 10.8 volts or less, and on the 4-cell lithium battery pack transmitters is 11.2 volts or less, the battery pack is below specification.
	Faulty transmitter.	3. If the battery-pack voltage meets the specifications in step 2, the battery-pack is O. K. If the battery is O. K. , check the transmitter as follows: <ol style="list-style-type: none"> a. Remove the voltmeter. b. By means of a switchcraft 750 jackplug and 3 inch maximum long leads, connect a Simpson Model 1223 ammeter to the jack. c. Set the toggle switch to ON and observe the ammeter current drain. If the current-drain is in the 85-100 ma range, the transmitter or the co-axial cable is faulty.
	Faulty co-axial antenna cable.	4. Check co-axial antenna cable for high resistance joints. If this is found to be the case, the cable should be replaced.

*This test should be carried out with the co-axial cable provided with your unit.

SHOP NOTES:

ELECTRICAL LOAD ANALYSIS CHART

ALL MODELS

STANDARD EQUIPMENT (RUNNING LOAD)	AMPS REQD							
	1969	1970	1971	1972	1973	1974	1975	1976
Battery Contactor	0.6	0.6	0.6	0.6	0.6	0.6	0.6	0.6
Fuel Indicators	0.4	0.4	0.4	0.4	0.4	0.4	0.4	0.4
Flashing Beacon Light **	7.0	7.0	7.0	7.0	7.0	7.0	7.0	7.0
Instrument Lights	1.1	1.1	1.1	1.1	1.1	1.1	1.1	1.1
Position Lights	5.6	5.6	5.6	5.6	5.6	5.6	5.6	5.6
Turn Coordinator *	0.8	0.8	0.8	0.8	0.8	0.8	0.8	0.8
OPTIONAL EQUIPMENT (RUNNING LOAD)								
Strobe Lights	—	—	3.0	3.0	3.0	3.0	3.0	3.0
Cessna 300 ADF (Type R-521B)	1.6	1.6	1.6	1.6	—	—	—	—
Cessna 300 ADF (Type R-546A)	—	—	—	1.0	1.0	1.0	1.0	1.0
Cessna 300 ADF (Type R-546E)	—	—	—	1.0	1.0	1.0	1.0	1.0
Cessna 300 Marker Beacon (Type R-502B)02	.02	.02	.02	.02	.02	.02	—
Cessna 300 Nav/Com (90 Channel-Type RT-517R)	4.5	4.5	4.5	—	—	—	—	—
Cessna 300 Nav/Com (360 Channel-Type RT-540A)	4.5	4.5	4.5	—	—	—	—	—
Cessna 300 Nav/Com (100 Channel-Type RT-508A)	—	—	—	1.9	1.9	—	—	—
Cessna 300 Nav/Com (RT-308C)	—	—	—	—	—	1.5	1.5	1.5
Cessna 300 Nav/Com (360 Channel-Type RT-528A)	—	—	—	1.9	1.9	—	—	—
Cessna 300 Nav/Com (360 Channel-Type RT-528E)	—	—	—	—	1.9	1.9	1.9	—
Cessna 300 Nav/Com (360 Channel-Type RT-528E-1)	—	—	—	—	—	—	—	1.5
Cessna 300 Nav/Com (360 Channel-Type RT-328A)	—	—	—	—	1.9	—	—	—
Cessna 300 Nav/Com (360 Channel-Type RT-328C)	—	—	—	—	—	1.5	—	—
Cessna 300 Nav/Com (720 Channel-Type RT-328D)	—	—	—	—	—	—	1.5	1.5
Cessna 300 Transceiver (Type RT-524A)	3.2	3.2	3.2	3.2	3.2	3.2	3.2	3.2
Cessna 300 Transponder (Type KT-75R)	1.5	1.5	1.5	1.5	—	—	—	—
Cessna 300 Transponder (Types KT-76 or KT-78)	—	—	—	1.3	1.3	—	—	—
Cessna 300 Transponder (RT-359A)	—	—	—	—	—	1.0	1.0	1.0
Cessna 300 Glideslope (Type R-543B)	0.5	0.5	0.5	0.5	0.5	—	—	—
Cessna 300 Glideslope (R-443B) (40 Channel)	—	—	—	—	—	0.5	0.5	0.5
Cessna 400 Marker Beacon (Type R-402A)	—	—	—	—	—	—	—	0.1
Cessna 400 Encoding Altimeter (Type EA-401A)	—	—	—	—	—	—	0.2	0.2
King KY-95 or KY-95E	4.0	4.0	4.0	—	—	—	—	—
King KT-76 Transponder	—	—	—	—	—	1.3	1.3	1.3
King KX-160E, AE or FE	2.5	2.5	2.5	—	—	—	—	—
King KX-160-1	—	2.5	2.5	—	—	—	—	—
Narco Mark 12A Nav/Com	4.6	—	—	—	—	—	—	—
Narco Mark 12B with VOA-40 or VOA-50	—	4.6	4.6	—	—	—	—	—
ITEMS NOT CONSIDERED AS PART OF RUNNING LOAD								
Cigar Lighter	10.0	10.0	10.0	10.0	10.0	10.0	10.0	10.0
Clock	†	†	†	†	†	†	†	†
Dome Light	0.3	0.3	0.3	0.3	0.3	0.3	0.3	0.3
Flap Motor	15.0	15.0	15.0	15.0	15.0	15.0	15.0	15.0
Landing Lights (Wing Mounted)	15.6	15.6	—	—	—	—	—	—
Landing Light (Cowl Mounted)	—	—	20.0	20.0	20.0	20.0	20.0	20.0
Landing and Taxi Lights (Dual Cowl Mounted)	—	—	—	—	—	15.6	15.6	15.6
† Negligible * Optional on the Standard Model 150 ** Optional on the Standard, Trainer and F150								

SECTION 18

STRUCTURAL REPAIR

TABLE OF CONTENTS	Page		
STRUCTURAL REPAIR	18-2	Wing Leading Edge	18-4
Repair Criteria	18-2	Negligible Damage	18-4
Equipment and Tools	18-2	Repairable Damage	18-4
Support Stands	18-2	Damage Necessitating Replace-	
Fuselage Repair Jigs	18-2	ment of Parts	18-4
Wing Jigs	18-2	Elevators and Rudder	18-4
Wing, Stabilizer Angle-of-Incidence		Negligible Damage	18-4
and Wing Twist	18-2	Repairable Damage	18-4
Repair Materials	18-2	Damage Necessitating Replace-	
Wing	18-2	ment of Parts	18-4
Description	18-2	Elevator and Rudder Balancing	18-4
Wing Skin	18-2	Fin and Stabilizer	18-4
Negligible Damage	18-2	Negligible Damage	18-4
Repairable Damage	18-2	Repairable Damage	18-4
Damage Necessitating Replace-		Damage Necessitating Replace-	
ment of Parts	18-3	ment of Parts	18-4
Wing Stringers	18-3	Fuselage	18-4
Negligible Damage	18-3	Description	18-4
Repairable Damage	18-3	Negligible Damage	18-4
Damage Necessitating Replace-		Repairable Damage	18-5
ment of Parts	18-3	Damage Necessitating Replace-	
Wing Auxiliary Spars	18-3	ment of Parts	18-5
Negligible Damage	18-3	Bulkheads	18-5
Repairable Damage	18-3	Landing Gear Bulkheads	18-5
Damage Necessitating Replace-		Repair After Hard Landing	18-5
ment of Parts	18-3	Replacement of Hi-Shear Rivets	18-5
Wing Ribs	18-3	Firewall Damage	18-5
Negligible Damage	18-3	Engine Mount	18-5
Repairable Damage	18-3	Description	18-5
Damage Necessitating Replace-		General Considerations	18-5
ment of Parts	18-3	Engine Mount Support Cradle	
Wing Spars	18-3	Damage	18-5
Negligible Damage	18-3	Damage Involving Engine Mount-	
Repairable Damage	18-3	ing Lugs and Engine Mount to	
Damage Necessitating Replace-		Fuselage Attach Fittings	18-5
ment of Parts	18-3	Baffles	18-5
Ailerons	18-3	Engine Cowling	18-5
Negligible Damage	18-3	Repair of Cowling Skins	18-5
Repairable Damage	18-3	Repair of Reinforcement	
Damage Necessitating Replace-		Angles	18-5
ment of Parts	18-3	Repair of Thermo-Formed Plastic	
Aileron Balancing	18-3	Components	18-5
Wing Flaps	18-3	Repair of Glass-Fiber	
Negligible Damage	18-3	Constructed Components	18-6
Repairable Damage	18-3		
Damage Necessitating Replace-			
ment of Parts	18-3		

18-1. STRUCTURAL REPAIR.

18-2. REPAIR CRITERIA. Although this section outlines repair permissible on structure of the aircraft, the decision of whether to repair or replace a major unit of structure will be influenced by such factors as time and labor available, and by a comparison of labor costs with the price of replacement assemblies. Past experience indicates that replacement, in many cases, is less costly than major repair. Certainly, when the aircraft must be restored to its airworthy condition in a limited length of time, replacement is preferable. Restoration of a damaged aircraft to its original design strength, shape, and alignment involves careful evaluation of the damage, followed by exacting workmanship in performing the repairs. This section suggests the extent of structural repair practicable on the aircraft, and supplements Federal Aviation Regulation, Part 43. Consult the factory when in doubt about a repair not specifically mentioned here.

18-3. EQUIPMENT AND TOOLS.

18-4. SUPPORT STANDS. Padded, reinforced sawhorse or tripod type support stands, sturdy enough to support any assembly placed upon them, must be used to store a removed wing or tailcone. Plans for local fabrication of support stands are contained in figure 18-1. The fuselage assembly, from the tailcone to the firewall must NOT be supported from the underside, since the skin bulkheads are not designed for this purpose. Adapt support stands to fasten to the wing-attach points or landing gear attach-points when supporting a fuselage.

18-5. FUSELAGE REPAIR JIGS. Whenever a repair is to be made which could affect structural alignment, suitable jigs must be used to assure correct alignment of major attach points, such as fuselage, firewall, wing and landing gear. These fuselage repair jigs are obtainable from the factory.

18-6. WING JIGS. These jigs serve as a holding fixture during extensive repair of a damaged wing, and locates the root rib, leading edge and tip rib of the wing. These jigs are also obtainable from the factory.

18-7. WING, HORIZONTAL STABILIZER ANGLE-OF-INCIDENCE AND WING TWIST.

18-8. The following chart lists wing angle-of-incidence and wing twist and horizontal stabilizer angle-of-incidence. Stabilizers do not have twist. Wings have a constant angle from the wing root to the strut fitting station. All twist in the wing panel is between the strut fitting and the tip rib. The amount of twist between these points is the difference between the angle-of-incidence at the root and the angle-of-incidence at the tip. Refer to figure 18-2 for instructions for checking wing twist.

WING

Angle-of-incidence, Root	+1°
Angle-of-incidence, Tip	0°
Twist (Washout)	1°

STABILIZER

Angle-of-incidence	-3°
------------------------------	-----

18-9. REPAIR MATERIALS. Thickness of a material on which a repair is to be made can easily be determined by measuring with a micrometer. In general, material used in Cessna aircraft covered in this manual is made from 2024 aluminum alloy, heat treated to a -T3, -T4, or -T42 condition. If the type of material cannot readily be determined, 2024-T3 may be used in making repairs, since the strength of -T3 is greater than -T4 or -T42 (-T4 and -T42 may be used interchangeably, but they may not be substituted for -T3). When necessary to form a part with a smaller bend radius than the standard cold bending radius for 2024-T4, use 2024-0 and heat treat to 2024-T42 after forming. The repair material used in making a repair must equal the gauge of the material being repaired unless otherwise noted. It is often practical to cut repair pieces from service parts listed in the Parts Catalog. A few components (empennage tips, for example) are fabricated from thermo-formed plastic or glass-fiber constructed material.

18-10. WING.

18-11. DESCRIPTION. The wing assemblies are a semicantilever type employing semimonocoque type of structure. Basically, the internal structure consists of built-up front and rear spar assemblies, a formed auxiliary spar assembly and formed sheet metal nose, intermediate, and trailing edge ribs. Stressed skin, riveted to the rib and spar structures, completes the rigid structure. Access openings (hand holes with removable cover plates) are located in the underside of the wing between the wing root and tip section. These openings afford access to aileron bellcranks, flap bellcranks, electrical wiring, strut attach fittings, control cables and pulleys, and control disconnect points.

18-12. WING SKIN.

18-13. NEGLIGIBLE DAMAGE. Any smooth dents in the wing skin that are free from cracks, abrasions and sharp corners, which are not stress wrinkles and do not interfere with any internal structure or mechanism, may be considered as negligible damage. In areas of low stress intensity, cracks, deep scratches, or deep, sharp dents, which after trimming or stop-drilling can be enclosed by a two-inch circle, can be considered negligible if the damaged area is at least one diameter of the enclosing circle away from all existing rivet lines and material edges. Stop drilling is considered a temporary repair and a permanent repair must be made as soon as practicable.

18-14. REPAIRABLE DAMAGE. Figure 18-4 outlines typical repair to be employed in patching skin. Before installing a patch, trim the damaged area to form a rectangular pattern, leaving at least a one-half inch radius at each corner, and de-burr. The sides of the hole should lie span-wise or chord-wise. A circular patch may also be used. If the patch is in an area where flush rivets are used, make a flush patch type of repair; if in an area where flush rivets

are not used, make an overlapping type of repair. Where optimum appearance and airflow are desired, the flush patch may be used. Careful workmanship will eliminate gaps at butt-joints; however, an epoxy type filler may be used at such joints.

18-15. DAMAGE NECESSITATING REPLACEMENT OF PARTS. If a skin is badly damaged, repair must be made by replacing an entire skin panel, from one structural member to the next. Repair seams must be made to lie along existing structural members and each seam must be made exactly the same in regard to rivet size, spacing, and pattern as the manufactured seams at the edges of the original sheet. If the manufactured seams are different, the stronger must be copied. If the repair ends at a structural member where no seam is used, enough repair panel must be used to allow an extra row of staggered rivets, with sufficient edge margin, to be installed.

18-16. WING STRINGERS.

18-17. NEGLIGIBLE DAMAGE. Refer to paragraph 18-13.

18-18. REPAIRABLE DAMAGE. Figure 18-5 outlines a typical wing stringer repair. Two such repairs may be used to splice a new section of stringer material in position, without the filler material.

18-19. DAMAGE NECESSITATING REPLACEMENT OF PARTS. If a stringer is so badly damaged that more than one section must be spliced, replacement is recommended.

18-20. WING AUXILIARY SPARS.

18-21. NEGLIGIBLE DAMAGE. Refer to paragraph 18-13.

18-22. REPAIRABLE DAMAGE. Figure 18-8 illustrates a typical auxiliary spar repair.

18-23. DAMAGE NECESSITATING REPLACEMENT OF PARTS. If damage to an auxiliary spar would require a repair which could not be made between adjacent ribs, the auxiliary spar must be replaced.

18-24. WING RIBS.

18-25. NEGLIGIBLE DAMAGE. Refer to paragraph 18-13.

18-26. REPAIRABLE DAMAGE. Figure 18-6 illustrates a typical wing rib repair.

18-27. DAMAGE NECESSITATING REPLACEMENT OF PARTS. Leading and trailing edge ribs that are extensively damaged can be replaced. However, due to the necessity of unfastening an excessive amount of skin in order to replace the rib, they should be repaired if practicable. Center ribs, between the front and rear spar should always be repaired if practicable.

18-28. WING SPARS.

18-29. NEGLIGIBLE DAMAGE. Due to the stress

which wing spars encounter, very little damage can be considered negligible. All cracks, stress wrinkles, deep scratches, and sharp dents must be repaired. Smooth dents, light scratches and abrasions may be considered negligible.

18-30. REPAIRABLE DAMAGE. Figure 18-7 illustrates typical spar repairs. It is often practical to cut repair pieces from service parts listed in the Parts Catalog. Service Kits are available for certain types of spar repairs.

18-31. DAMAGE NECESSITATING REPLACEMENT OF PARTS. Damage so extensive that repair is not practicable requires replacement of a complete wing spar. Also refer to paragraph 18-2.

18-32. AILERONS.

18-33. NEGLIGIBLE DAMAGE. Refer to paragraph 18-13.

18-34. REPAIRABLE DAMAGE. Figure 18-3A may be used as a guide to repair damage to aileron skins. It is recommended that all material used for the repair be cut from spare parts of the same gauge and corrugation spacing. Repair should extend from the leading edge to the trailing edge. Following the repair, the aileron must be balanced. Refer to paragraph 18-36 and figure 18-3A for balancing. If damage would require a repair which could not be made between adjacent ribs, refer to paragraph 18-35.

18-35. DAMAGE NECESSITATING REPLACEMENT OF PARTS. If the damage would require a repair which could not be made between adjacent ribs, complete skin panels must be replaced. Ribs and spars may be repaired, but replacement is generally preferable. Where extensive damage has occurred, replacement of the aileron assembly is recommended. After repair and/or replacement, balance aileron in accordance with paragraph 18-36 and figure 18-3.

18-36. AILERON BALANCING. Following repair, replacement or painting, the aileron must be balanced. Complete instructions for fabricating balancing fixtures and mandrels and their use are given in figure 18-3.

18-37. WING FLAPS.

18-38. NEGLIGIBLE DAMAGE. Refer to paragraph 18-13.

18-39. REPAIRABLE DAMAGE. Flap repairs should be similar to aileron repairs discussed in paragraph 18-34. A flap leading edge repair is shown in figure 18-10.

18-40. DAMAGE NECESSITATING REPLACEMENT OF PARTS. Flap repairs which require replacement of parts should be similar to aileron repairs discussed in paragraph 18-35. Since the flap is not considered a moveable control surface, no balancing is required.

18-41. WING LEADING EDGE.

18-42. NEGLIGIBLE DAMAGE. Refer to paragraph 18-13.

18-43. REPAIRABLE DAMAGE. A typical leading edge skin repair is shown in figure 18-9. An epoxy-type filler may be used to fill gaps at butt-joints. To facilitate repair, extra access holes may be installed in the locations noted in figure 18-11. If the damage would require a repair which could not be made between adjacent ribs, refer to the following paragraph.

18-44. DAMAGE NECESSITATING REPLACEMENT OF PARTS. For extensive damage, complete leading edge skin panels must be replaced. To facilitate replacement, extra access holes may be installed in the locations noted in figure 18-11.

18-45. ELEVATORS AND RUDDER.

18-46. NEGLIGIBLE DAMAGE. Refer to paragraph 18-13. The exception to negligible damage on the elevator surfaces is the front spar, where a crack appearing in the web at the hinge fittings or in the structure which supports the overhanging balance weight is not considered negligible. Cracks in the overhanging tip rib, in the area at the front spar intersection with the web of the rib, also cannot be considered negligible.

18-47. REPAIRABLE DAMAGE. Skin patches illustrated in figure 18-4 may be used to repair skin damage. Following repair, the elevators and rudder must be balanced. Refer to paragraph 18-49 and figure 18-3 for balancing the elevators and rudder. If damage would require a repair which could not be made between adjacent ribs, see the following paragraph.

18-48. DAMAGE NECESSITATING REPLACEMENT OF PARTS. If the damaged area would require a repair which could not be made between adjacent ribs, complete skin panels must be replaced. Ribs and spars may be repaired, but replacement is generally preferable. Where extensive damage has occurred, replacement of the entire assembly is recommended. After repair and/or replacement, balance elevators and rudder in accordance with paragraph 18-49 and figure 18-3.

18-49. ELEVATOR AND RUDDER BALANCING. Following repair, replacement or painting, the elevators and rudder must be balanced. Complete instructions for fabricating balancing fixtures and mandrels and their use are given in figure 18-3.

18-50. FIN AND STABILIZER.

18-51. NEGLIGIBLE DAMAGE. Refer to paragraph 18-13.

18-52. REPAIRABLE DAMAGE. Skin patches illustrated in figure 18-4 may be used to repair skin damage. Access to the dorsal area of the fin may be gained by removing the horizontal closing rib at the

bottom of the fin. Access to the internal fin structure is best gained by removing skin attaching rivets on one side of the rear spar and ribs, and springing back the skin. Access to the stabilizer structure may be gained by removing skin attaching rivets on one side of the rear spar and ribs, and springing back the skin. If the damaged area would require a repair which could not be made between adjacent ribs, or a repair would be located in an area with compound curves, see the following paragraph.

18-53. DAMAGE NECESSITATING REPLACEMENT OF PARTS. If the damaged area would require a repair which could not be made between adjacent ribs, or the repair would be located in an area with compound curves, complete skin panels must be replaced. Ribs and spars may be repaired, but replacement is generally preferable. Where damage is extensive, replacement of the entire assembly is recommended.

18-54. FUSELAGE.

18-55. DESCRIPTION. The fuselage is of semi-monocoque construction, consisting of formed bulkheads, longitudinal stringers, reinforcing channels, and skin panels.

18-56. NEGLIGIBLE DAMAGE. Refer to paragraph 18-13. Mild corrosion appearing upon alclad surfaces does not necessarily indicate incipient failure of the base metal. However, corrosion of all types must be carefully considered, and approved remedial action taken. Small cans appear in the skin structure of all metal aircraft. It is strongly recommended however, that wrinkles which appear to have originated from other sources, or which do not follow the general appearance of the remainder of the skin panels, be thoroughly investigated. Except in the landing gear bulkhead areas, wrinkles occurring over stringers which disappear when the rivet pattern is removed, may be considered negligible. However, the stringer rivet holes may not align perfectly with the skin holes because of a permanent "set" in the stringer. If this is apparent, replacement of the stringer will usually restore the original strength characteristics of the area.

NOTE

Wrinkles occurring in the skin of the main landing gear bulkhead areas must not be considered negligible. The skin panel must be opened sufficiently to permit a thorough examination of the lower portion of the landing gear bulkhead and its tie-in structure.

Wrinkles occurring in open areas which disappear when the rivets at the edge of the sheet are removed, or a wrinkle which is hand removable, may often be repaired by the addition of a 1/2 x 1/2 x .060 inch 2024-T4 extruded angle, riveted over the wrinkle and extended to within 1/16 to 1/8 inch of the nearest structural members. Rivet pattern should be identical to existing manufactured seam at edge of sheet. Negligible damage to stringers, formed skin flanges, bulkhead channels, and like parts is similar to that for the wing skin, given in paragraph 18-13.

18-57. REPAIRABLE DAMAGE. Fuselage skin repairs may be accomplished in the same manner as wing skin repairs outlined in paragraph 18-14. Stringers, formed skin flanges, bulkhead channels and similar parts may be repaired as shown in figure 18-5.

18-58. DAMAGE NECESSITATING REPLACEMENT OF PARTS. Fuselage skin major repairs may be accomplished in the same manner as the wing repairs outlined in paragraph 18-15. Damaged fittings must be replaced. Seat rails serve as structural parts of the fuselage and must be replaced if damaged.

18-59. BULKHEADS.

18-60. LANDING GEAR BULKHEADS. Since these bulkheads are highly stressed members, irregularly formed to provide clearance for control cables, fuel lines, etc., the patch-type repairs will be, for the most part, impractical. Minor damage, consisting of small nicks or scratches, may be repaired by dressing out the damaged area, or by replacement of rivets. Any other such damage must be repaired by replacing the landing gear support assembly as an aligned unit.

18-61. REPAIR AFTER HARD LANDING. Buckled skin or floorboards, and loose or sheared rivets in the area of the main gear support will give evidence of damage to the structure from an extremely hard landing. When such evidence is present, the entire support structure must be examined, and all support forgings must be checked for cracks, using a dye penetrant and proper magnification. Bulkheads in the damaged area must be checked for alignment, and deformation of the bulkhead webs must be determined with the aid of a straightedge. Damaged support structure, buckled floorboards and skins, and damaged or questionable forgings must be replaced.

18-62. REPLACEMENT OF HI-SHEAR RIVETS. Hi-shear rivet replacement with close tolerance bolts or other commercial fasteners of equivalent strength properties is permissible. Holes must not be elongated, and the Hi-shear substitute must be a smooth push fit. Field replacement of main landing gear forgings or bulkheads may be accomplished by using:

- a. NAS464P* Bolt, MS21042-* Nut and AN960-* washer in place of Hi-shear rivets for forgings with machined flat surface around attachment holes.
- b. NAS464P* Bolt, ESNA2935* Mating Base Ring, ESNA LH2935* Nut for forgings (with draft, angle of up to a maximum of 8°) without machined flat surface around attachment holes.

*Dash numbers to be determined according to the size of the holes and the grip lengths required. The bolts grip length should be chosen so that No threads remain in the bearing area.

18-63. FIREWALL DAMAGE. Firewalls may be repaired by removing the damaged material and splicing in a new section. The new portion must be lapped over the old material, sealed with Pro-Seal #700

(Coast Pro-Seal Co., Chemical Division, 2235 Beverly Blvd, Los Angeles, California), compound or equivalent, and secured with stainless steel rivets. Damaged or deformed angles and stiffeners may be repaired as shown in figure 18-12, or they may be replaced. A severely damaged firewall must be replaced as a unit.

18-64. ENGINE MOUNT.

18-65. DESCRIPTION. The mount for the aircraft engine is constructed of 4130 chrome-molybdenum steel tubing. A truss structure, fastened to the firewall at four points, supports a cradle arrangement. This cradle arrangement with its supporting lugs, forms the base for rubber shock mounted engine supports.

18-66. GENERAL CONSIDERATIONS. All welding on the engine mount must be of the highest quality since the tendency of vibration is to accentuate any minor defect present and cause fatigue cracks. Engine mount members are preferably repaired by using a larger diameter replacement tube, telescoped over the stub of the original member using fishmouth and rosette type welds. However, reinforced 30-degree scarf welds in place of the fishmouth welds are considered satisfactory for engine mount repair work.

18-67. ENGINE MOUNT SUPPORT CRADLE DAMAGE. Minor damage such as a crack adjacent to an engine attaching lug may be repaired by rewelding the cradle tube and extending a gusset past the damaged area. Extensively damaged parts must be replaced.

18-68. DAMAGE INVOLVING ENGINE MOUNTING LUGS AND ENGINE MOUNT TO FUSELAGE ATTACHING FITTINGS. Engine mounting lugs and engine mount-to-fuselage attaching fittings should not be repaired but must be replaced.

18-69. BAFFLES. Baffles ordinarily require replacement if damaged or cracked. However, small plate reinforcements riveted to the baffle will often prove satisfactory both to the strength and cooling requirements of the unit.

18-70. ENGINE COWLING.

18-71. REPAIR OF COWLING SKINS. If extensively damaged, complete sections of cowlings must be replaced. Standard insert-type skin patches, however, may be used if repair parts are formed to fit. Small cracks may be stop-drilled and dents straightened if they are reinforced on the inner side with a doubler of the same material.

18-72. REPAIR OF REINFORCEMENT ANGLES. Cowl reinforcement angles, if damaged, must be replaced. Due to their small size they are easier to replace than to repair.

18-73. REPAIR OF ABS COMPONENTS. Rezolin Repair Kit Number 404 may be obtained from the Cessna Service Parts Center for repair of ABS components.

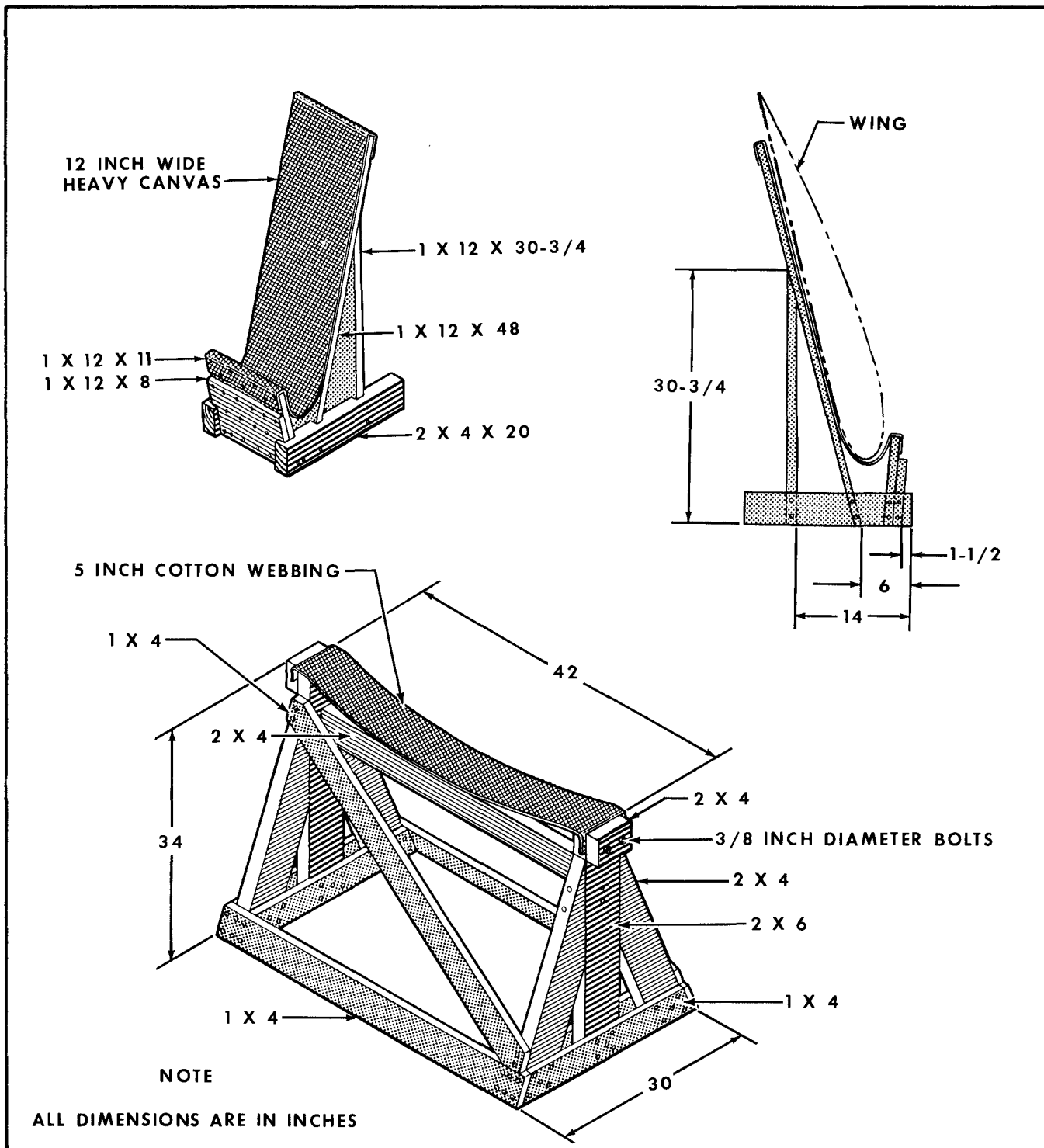
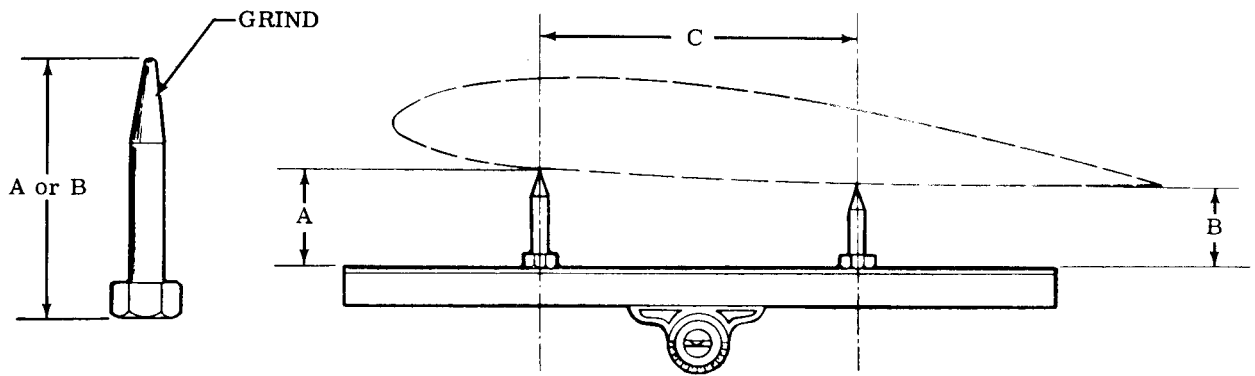

Figure 18-1. Wing and Fuselage Support Stands

18-74. REPAIR OF GLASS-FIBER CONSTRUCTED COMPONENTS. Glass-fiber constructed components on the aircraft may be repaired as stipulated in instructions furnished in Service Kit SK182-12. Observe the resin manufacturer's recommendations

concerning mixing and application of the resin. Epoxy resins are preferable for making repairs, since epoxy compounds are usually more stable and predictable than polyester and, in addition, give better adhesion.



MODLE	A	B	C	WING STATION
150	2.00	1.00	29.50	39.00
SERIES	2.00	1.00	29.50	84.00
	1.38	1.00	24.00	191.00

ALL WING TWIST OCCURS BETWEEN STA. 84.00
AND STA. 191.00.
(Refer to paragraph 18-7 for angle of incidence).

MEASURING WING TWIST

If damage has occurred to a wing, it is advisable to check the twist. The following method can be used with a minimum of equipment, which includes a straightedge (32" minimum length of angle, or equivalent), three modified bolts for a specific wing, and a protractor head with level.

1. Check chart for applicable dimension for bolt length (A or B).
2. Grind bolt shanks to a rounded point as illustrated, checking length periodically.
3. Tape two bolts to straightedge according to dimension C.
4. Locate inboard wing station to be checked and make a pencil mark approximately one-half inch aft of the lateral row of rivets in the wing leading edge spar flange.
5. Holding straightedge parallel to wing station (staying as clear as possible from "cans"), place longer bolt on pencil mark and set protractor head against lower edge of straightedge.
6. Set bubble in level to center and lock protractor to hold this reading.
7. Omitting step 6, repeat procedure for each wing station, using dimensions specified in chart. Check to see that protractor bubble is still centered.
8. Proper twist is present in wing if protractor readings are the same (parallel). Forward or aft bolt may be lowered from wing .10 inch maximum to attain parallelism.

Figure 18-2. Measuring Wing Twist

BALANCING PROCEDURES

1. Balance control surfaces in an enclosed draft free area.
2. Control surface to be balanced must be in the final flight configuration, painted (if applicable) trim tabs installed, and all foreign matter removed from inside control surface.
3. If control surface is to be painted remove all existing paint prior to repainting and rebalancing. Good workmanship and standard repair practices should not result in excessive additional balance weight.
4. Place balancing mandrels (detail B) on a table or other suitable FLAT, LEVELED surface. Mandrels must be placed at 90° to the hinge line of the control surface.
5. On control surfaces with the piano type hinges, insert inboard and outboard hinges into slotted ends of the balancing mandrels, making sure that balancing mandrels are 90° to the hinge line. On control surfaces with the bearing type hinge point, bolts or pins are inserted through the attaching brackets, then placed on the knife edges of the mandrels as illustrated in (detail H).
6. AILERONS.
 - a.
 - (1) Block up the trailing edge of the aileron until a spirit-level protractor placed on the front face of the aileron spar at W.S. 138.00 (± 6.00), (detail E), indicates 57° 10', (detail D).
 - (2) ALTERNATE METHOD:
Measure the vertical distance from the aileron hinge point to the leveled surface. Subtract 1.80 inches, then block up trailing edge of the aileron to this measurement.
 - b. With the aileron blocked in position place the balancing beam (detail A) at W.S. 138.00, (90° to the hinge line), and adjust the trailing edge support on the balancing beam (detail D) until the beam is level. If the aileron has not been disturbed during this operation, the beam is now parallel to the aileron chord line at W.S. 138.00 (detail D).

NOTE

The above procedure must be performed with care. Small angular discrepancies will produce large balancing errors.

- c. Remove balancing beam and balance the beam by itself at the knife edges by adding washers as shown, (detail C).
- d. Place the balancing beam on the aileron in its original position, then remove the blocks from beneath the trailing edge.
- e. Place the sliding weight (detail D) on the forward end of the balancing beam, moving it along the beam until the beam is again level. A small, lightweight, spirit level may be used for this purpose provided it is symmetrical about its bubble reference and this reference is placed on the beam directly over the aileron hinge line (detail D).
- f. If aileron is correctly balanced, the position of the sliding weight with respect to the aileron hinge line, will produce a moment about the hinge line somewhere within the underbalance tolerance listed in the chart on (Sheet 5 of 5).
- g. If modification of the aileron balance weight is necessary to correct an out-of-tolerance condition, the balance weight can be lightened by drilling out part of the weight on the inboard end. The weight can be increased by a reasonable amount by ordering additional weight and gang channel listed in the applicable Parts Catalog, and installing next to the existing weight the minimum amount necessary for correct balance. The minimum amount that must be installed, however, must contain at least two attaching rivets. If this minimum amount results in an over-balanced condition, the new weight and/or old weights can be lightened.

Figure 18-3. Control Surface Balancing (Sheet 1 of 5)

7. RUDDER AND ELEVATORS.

- a. With the rudder/elevator set upon a **FLAT, LEVELED** surface, block up the trailing edge until a center line through the attaching bolt and the trailing edge is equal distance from the leveling surface (detail H).
- b. Place the balancing beam (detail A) on the rudder/elevator near the center attaching bracket, (90° to the hinge line). Adjust the trailing edge support on the balancing beam (detail H) until the beam is level. If the rudder/elevator has not been disturbed during this operation, the beam is now parallel to the chord line of the rudder/elevator.

NOTE

The above procedure must be performed with care. Small angular discrepancies will produce large balancing errors.

- c. Mark position of the balancing beam, then remove and balance the beam by itself at the knife edges by adding washers as shown in (detail C).
- d. Place the balancing beam on the rudder/elevator in its original position, then remove the block from beneath the trailing edge.
- e. Place the sliding weight (detail H) on the forward end of the balancing beam, move it along the beam until the beam is again level. A small, lightweight, spirit level may be used for this purpose provided it is symmetrical about its bubble reference and this reference is placed on the beam directly over the rudder/elevator hinge line (detail H).
- f. If the rudder/elevator is correctly balanced, the position of the sliding weight with respect to the rudder/elevator hinge line, will produce a moment about the hinge line somewhere within the underbalance tolerance listed in the chart on (Sheet 5 of 5).
- g. If modification of the rudder/elevator balance weight is necessary to correct an out-of-balance condition, the balance weight can be lightened by drilling out part of the weight. The weight can be increased by fusing bar stock solder to the weight after removal from rudder/elevator.

BALANCING BEAM

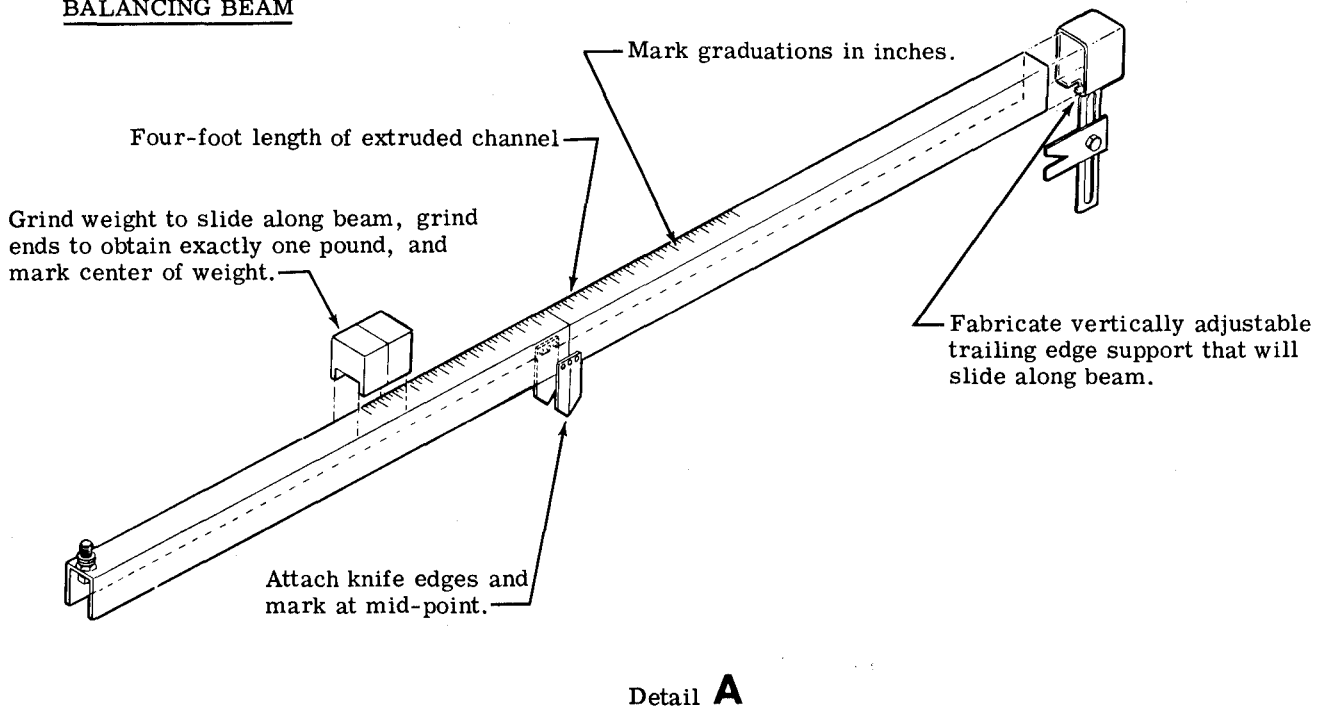
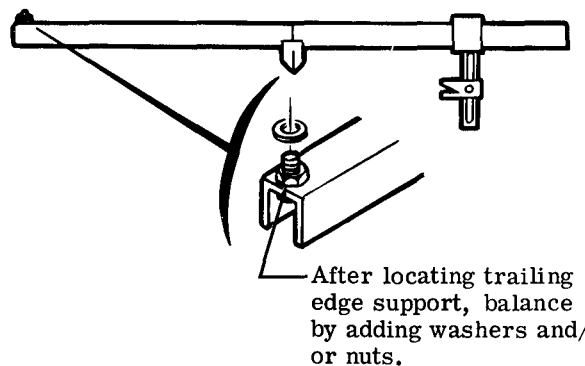
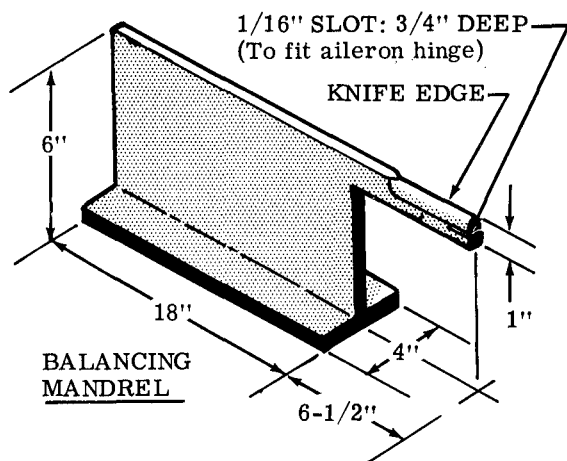
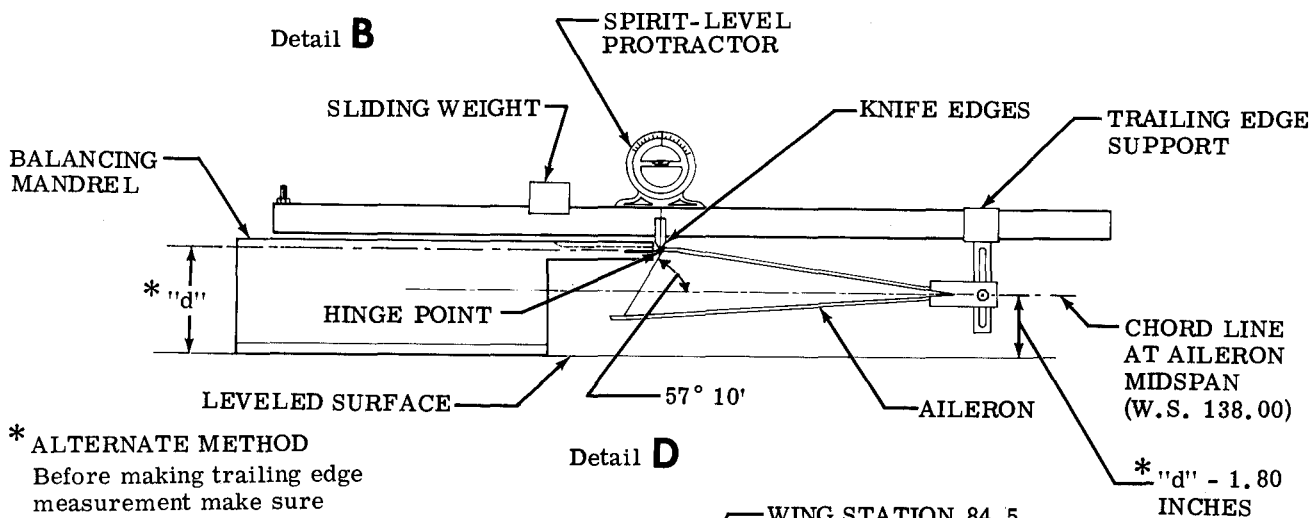

Figure 18-3. Control Surface Balancing (Sheet 2 of 5)



Detail C



Detail D

* ALTERNATE METHOD
Before making trailing edge measurement make sure that the trailing edge of the aileron is straight in this area.

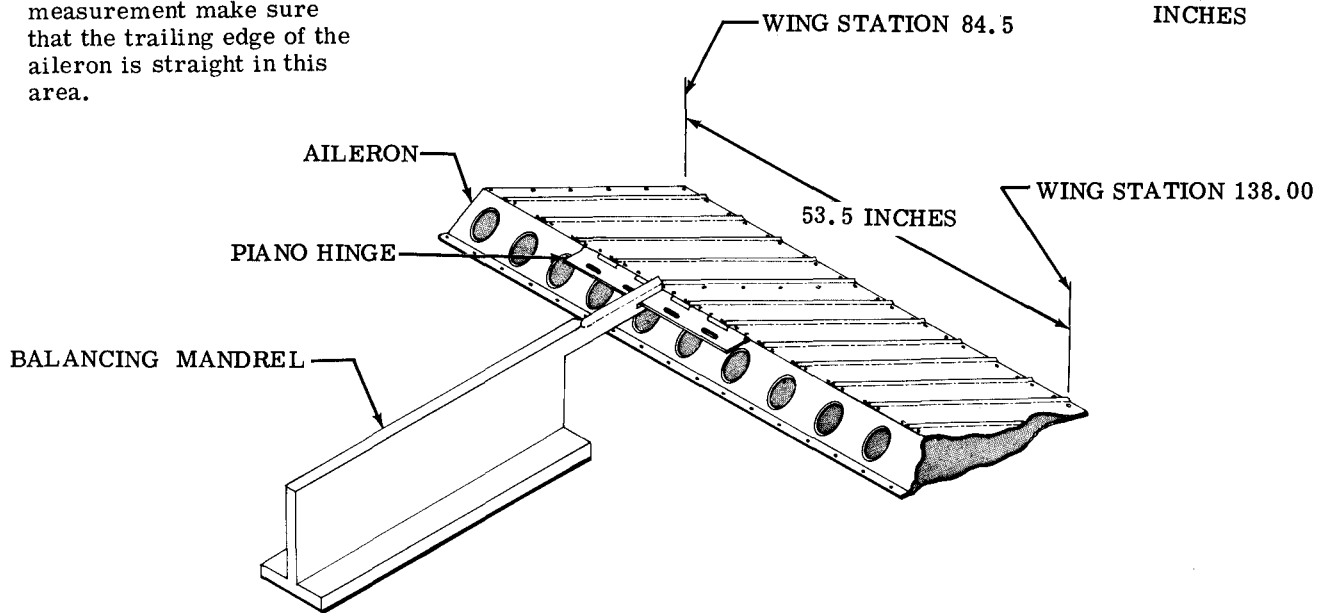

Detail E

Figure 18-3. Control Surface Balancing (Sheet 3 of 5)

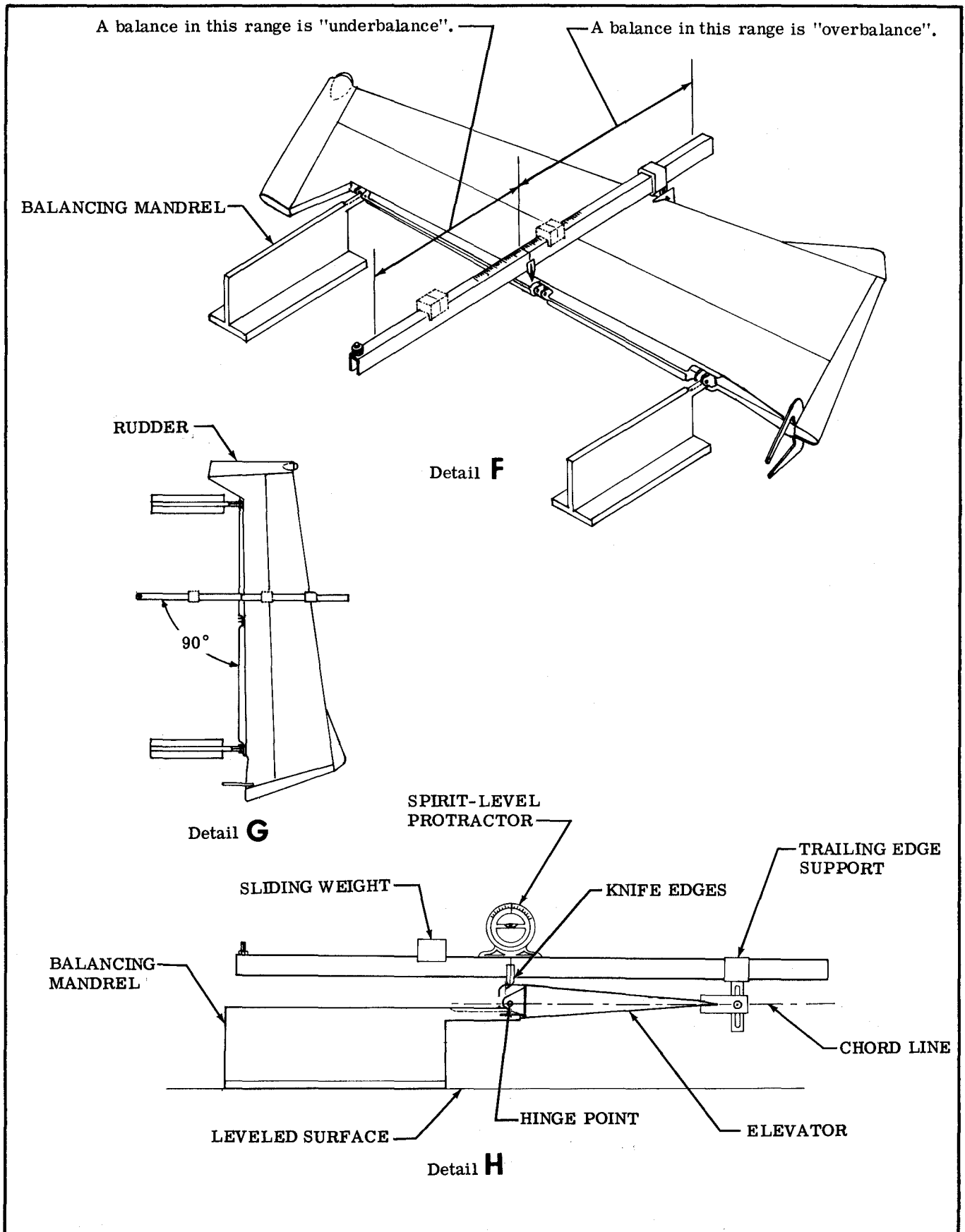

Figure 18-3. Control Surface Balancing (Sheet 4 of 5)

CONTROL SURFACE BALANCE REQUIREMENTS

NOTE

Unpainted values are not limits which must be met. They are given as guides, in order that the unbalance of the control surface in the final aircraft configuration may be predicted. If the control surface in the unpainted condition falls within the unpainted limit, the mechanic may feel confident that the control surface will be acceptable after painting. However, if the surface in the unpainted condition exceeds the unpainted limit, the balance must be checked again after final painting to assure that the control surface falls within the painted unbalance limit. Refer to GENERAL NOTES on sheet 3 for specific conditions.

DEFINITIONS:

UNDERBALANCE is defined as the condition that exists when the control surface is trailing edge heavy, and is symbolized by a plus (+).

OVERBALANCE is defined as the condition that exists when the control surface is leading edge heavy, and is symbolized by a minus (-).

CONTROL: AILERON

PAINTED (Inch-Pounds)	UNPAINTED (Inch-Pounds)
BALANCE LIMITS	BALANCE LIMITS
0.0 to + 8.94 (1969 MODELS) 0.0 to + 11.31 (1970 MODELS AND ON)	0.0 to + 8.58 (1969 MODELS) 0.0 to + 9.23 (1970 MODELS AND ON)

CONTROL: RUDDER

PAINTED (Inch-Pounds)	UNPAINTED (Inch-Pounds)
BALANCE LIMITS	BALANCE LIMITS
0.0 to + 6.00 (1969 MODELS) 0.0 to + 9.043 (1970 MODELS AND ON)	0.0 to + 4.00 (1969 MODELS) 0.0 to + 7.00 (1970 MODELS AND ON)

CONTROL: RIGHT ELEVATOR

PAINTED (Inch-Pounds)	UNPAINTED (Inch-Pounds)
BALANCE LIMITS	BALANCE LIMITS
0.0 to + 13.31 (1969 MODELS) 0.0 to + 14.109 (1970 MODELS AND ON)	0.0 to + 11.88 (1969 MODELS) 0.0 to + 11.88 (1970 MODELS AND ON)

CONTROL: LEFT ELEVATOR

PAINTED (Inch-Pounds)	UNPAINTED (Inch-Pounds)
BALANCE LIMITS	BALANCE LIMITS
0.0 to + 13.29 (1969 MODELS) 0.0 to + 14.109 (1970 MODELS AND ON)	0.0 to + 11.86 (1969 MODELS) 0.0 to + 11.88 (1970 MODELS AND ON)

Figure 18-3. Control Surface Balancing (Sheet 5 of 5)

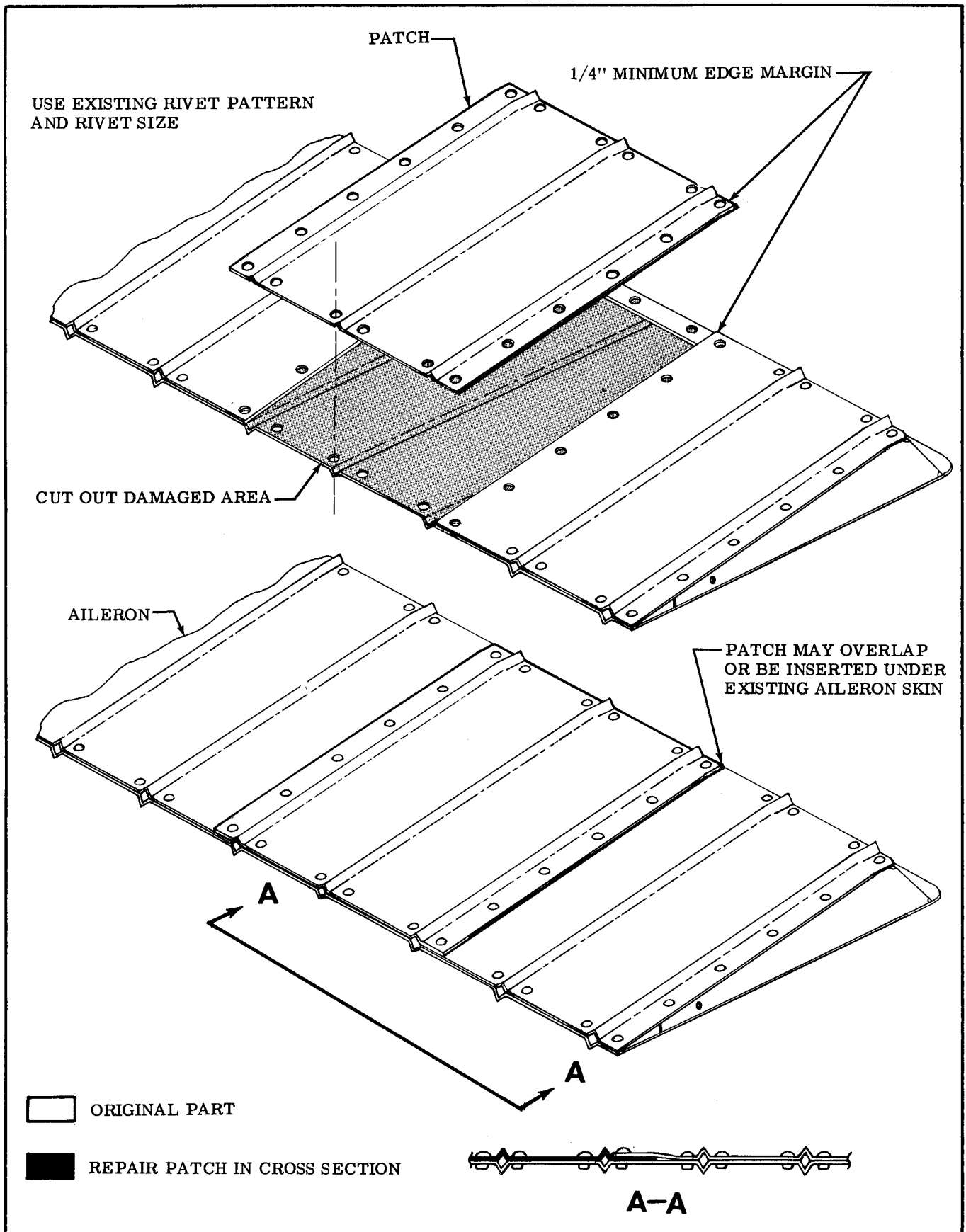
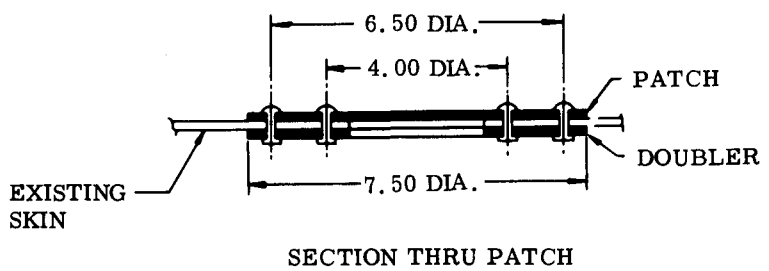
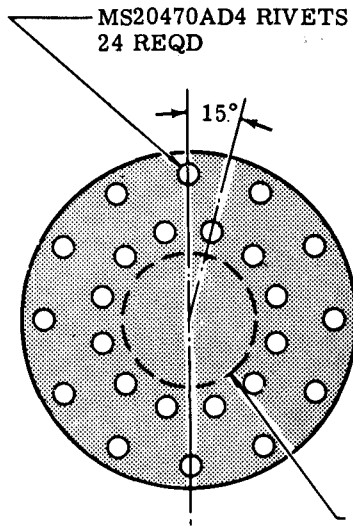
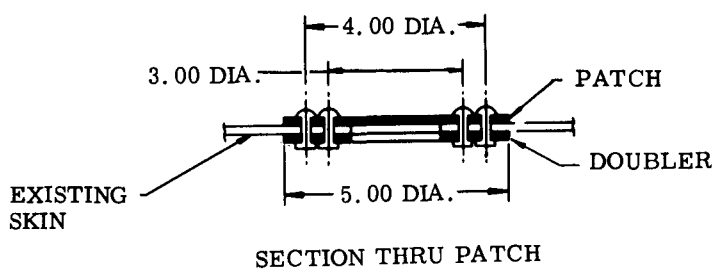
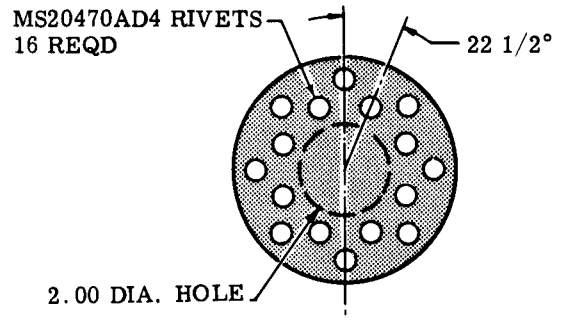

Figure 18-3A. Corrugated Skin Repair

PATCHES AND DOUBLERS —
2024-T3 ALCLAD



PATCH REPAIR FOR 3 INCH DIAMETER HOLE



PATCH REPAIR FOR 2 INCH DIAMETER HOLE

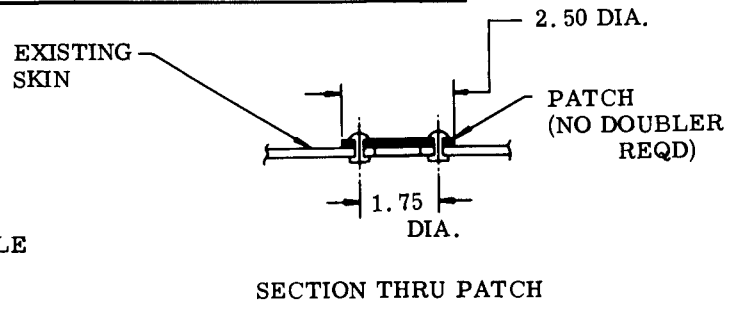
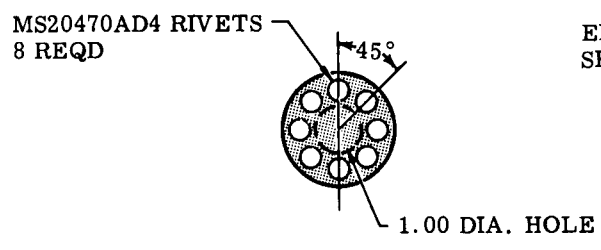

PATCH REPAIR FOR 1 INCH DIAMETER HOLE

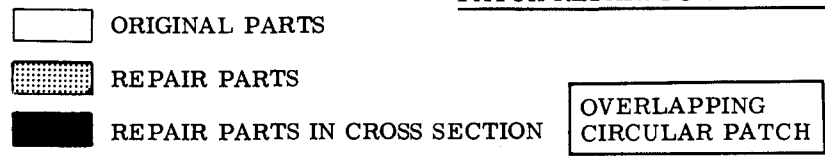
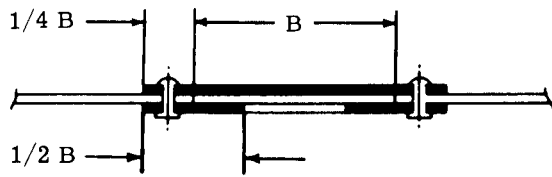
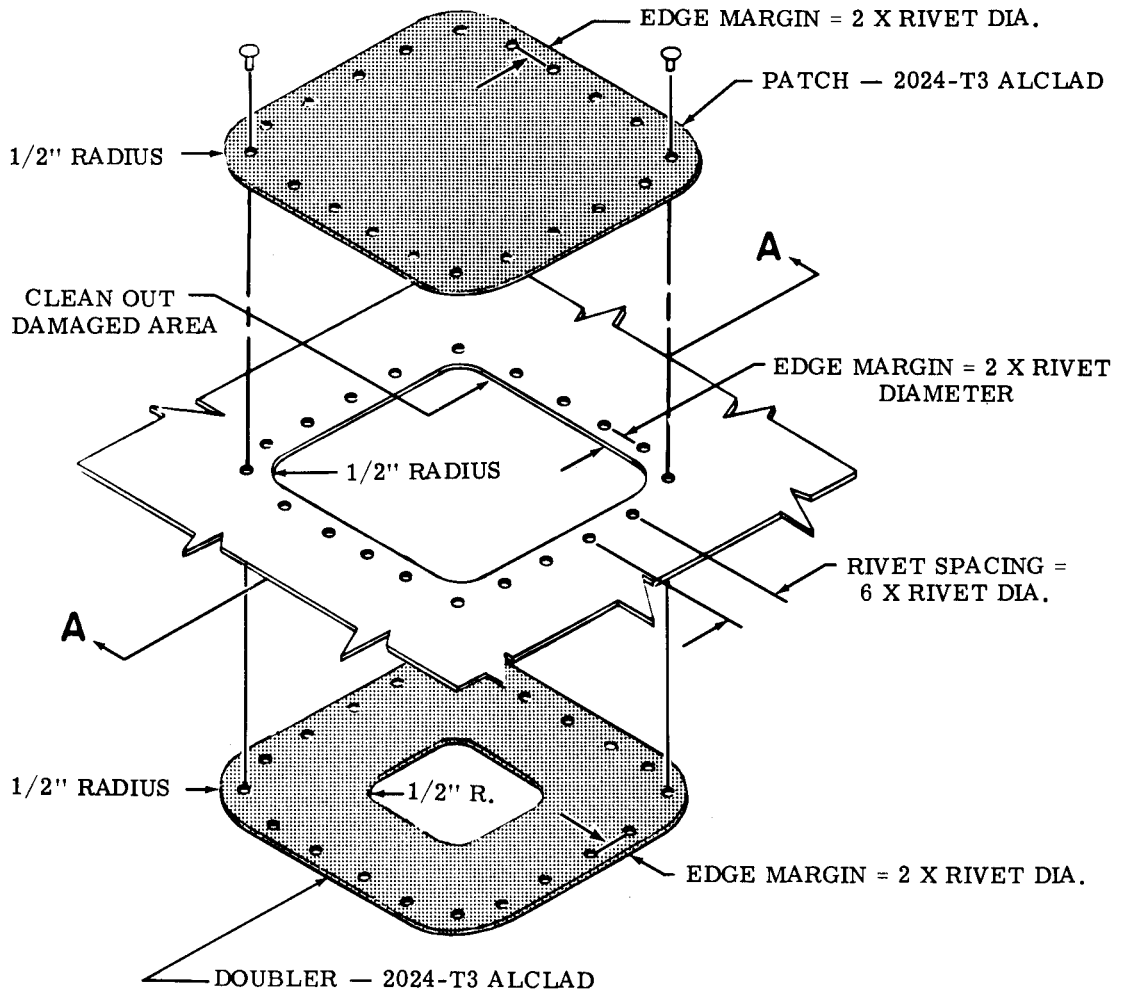

Figure 18-4. Skin Repair (Sheet 1 of 6)



SECTION THRU ASSEMBLED PATCH

A-A



- ORIGINAL PARTS
- REPAIR PARTS
- REPAIR PARTS IN CROSS SECTION

OVERLAPPING REC-TANGULAR PATCH

RIVET TABLE	
SKIN GAGE	RIVET DIA.
.020	1/8
.025	1/8
.032	1/8
.040	1/8
.051	5/32

Figure 18-4. Skin Repair (Sheet 2 of 6)

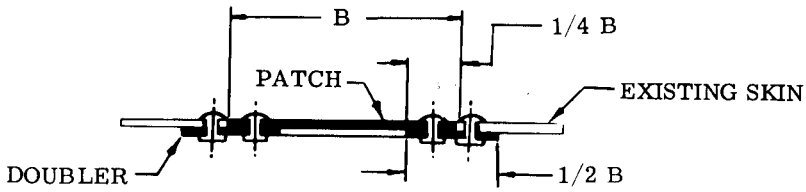

NOTE

For optimum appearance and airflow, use flush rivets, dimpled skin and patch, and counter-sunk doubler.

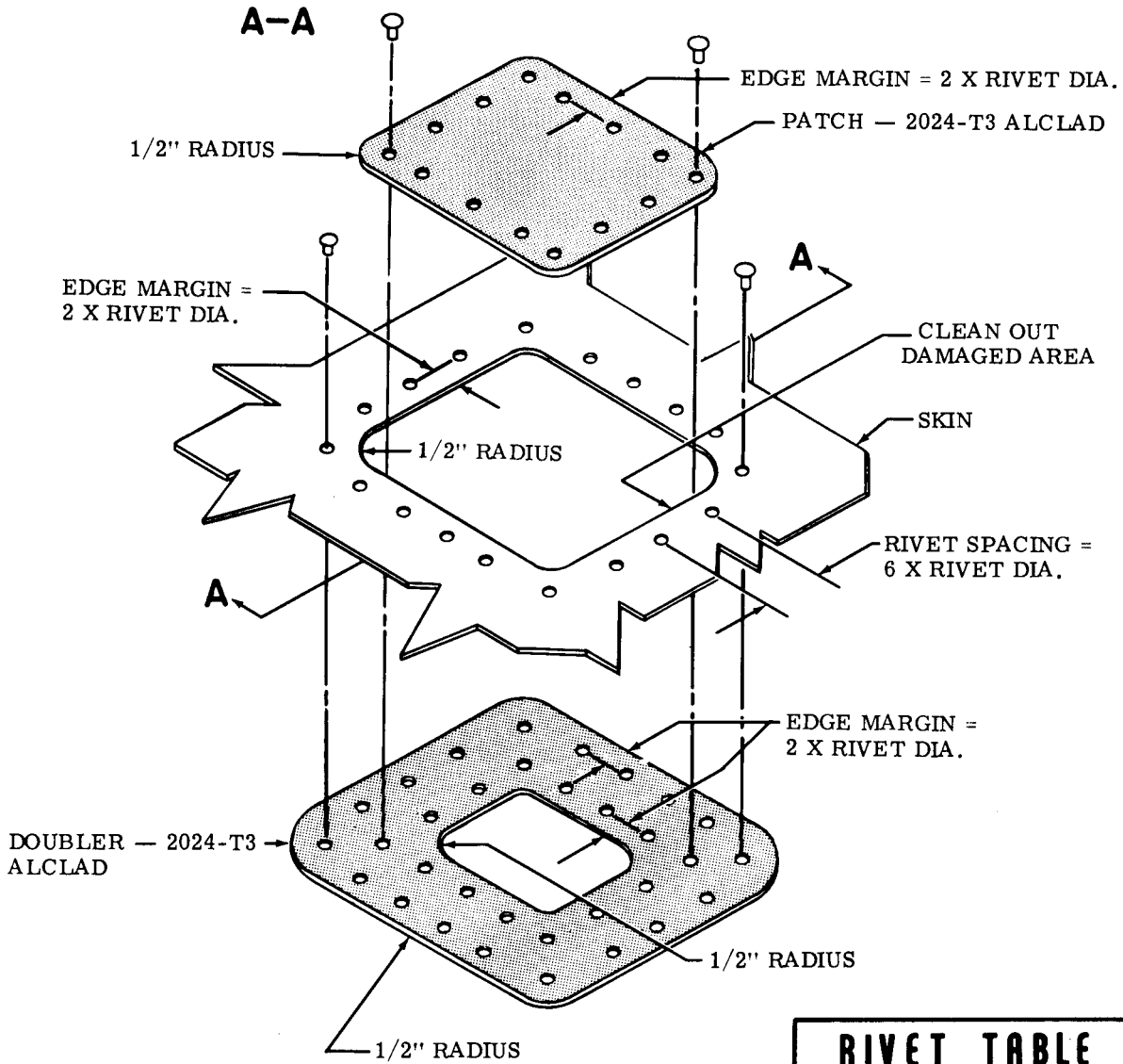

- ORIGINAL PARTS
- REPAIR PARTS
- REPAIR PARTS IN CROSS SECTION

FLUSH RECTANGULAR PATCH
(CIRCULAR FLUSH PATCH IS SIMILAR)

RIVET TABLE	
SKIN GAGE	RIVET DIA.
.020	1/8
.025	1/8
.032	1/8
.040	1/8
.051	5/32

Figure 18-4. Skin Repair (Sheet 3 of 6)

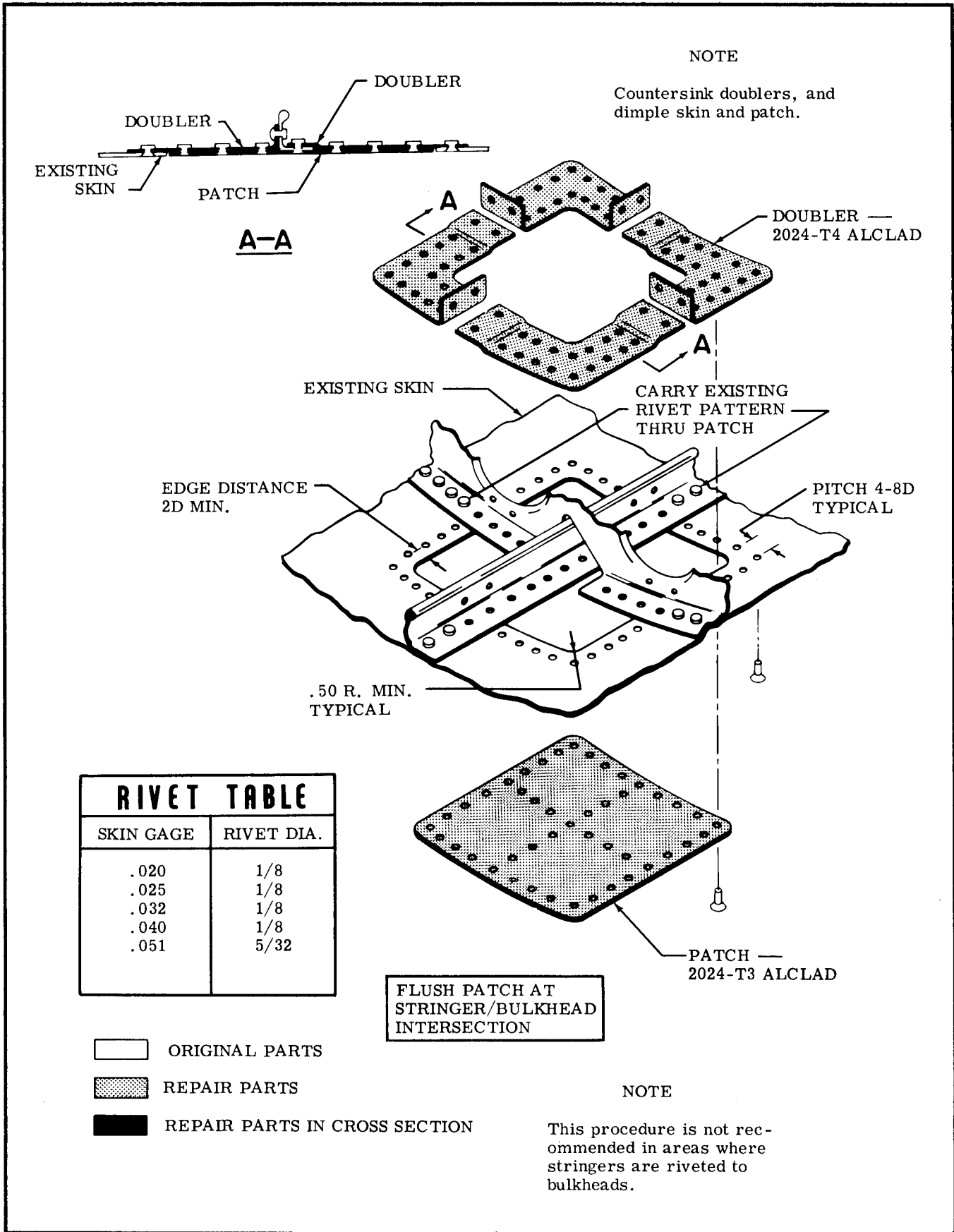

RIVET TABLE	
SKIN GAGE	RIVET DIA.
.020	1/8
.025	1/8
.032	1/8
.040	1/8
.051	5/32

- ORIGINAL PARTS
- REPAIR PARTS
- REPAIR PARTS IN CROSS SECTION

Figure 18-4. Skin Repair (Sheet 4 of 6)

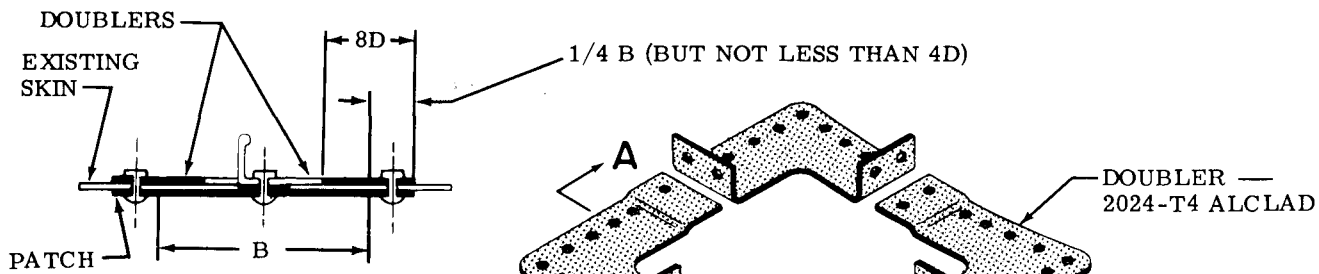

A-A

SECTION THRU ASSEMBLED PATCH

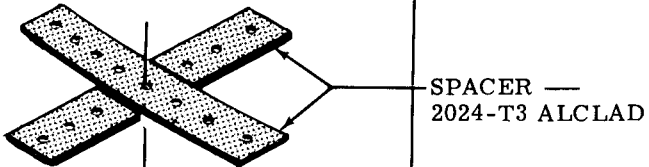
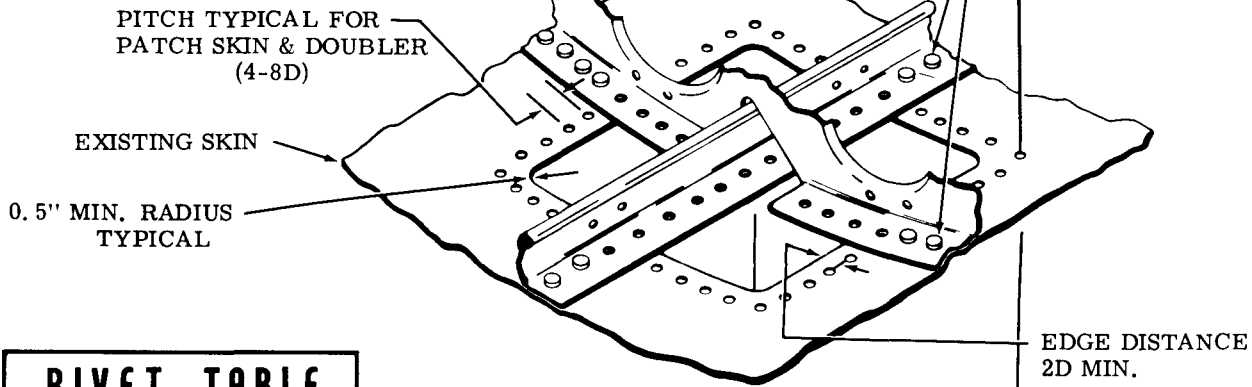
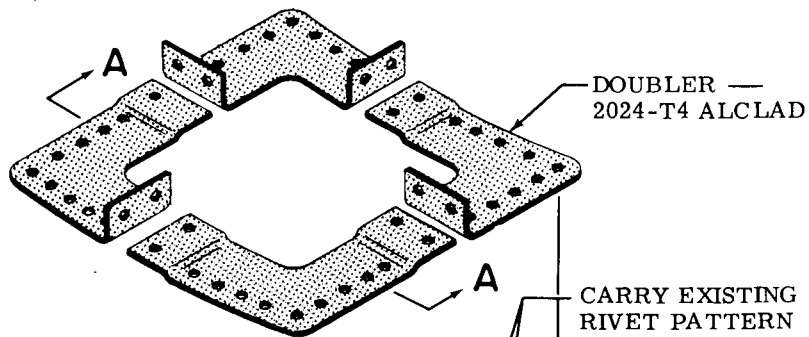

RIVET TABLE	
SKIN GAGE	RIVET DIA.
.020	1/8
.025	1/8
.032	1/8
.040	1/8
.051	5/32

OVERLAPPING PATCH AT STRINGER/BULKHEAD INTERSECTION

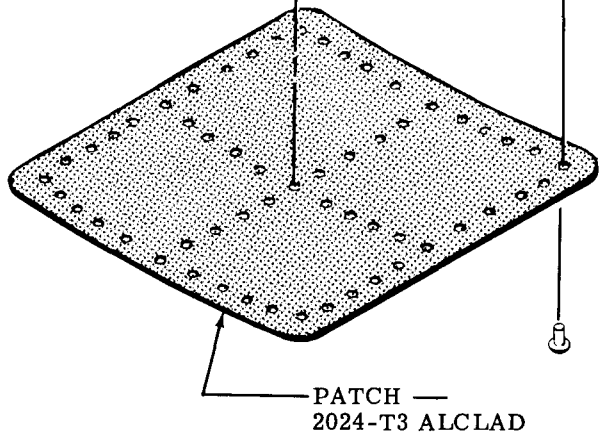

- ORIGINAL PARTS
- REPAIR PARTS
- REPAIR PARTS IN CROSS SECTION

Figure 18-4. Skin Repair (Sheet 5 of 6)

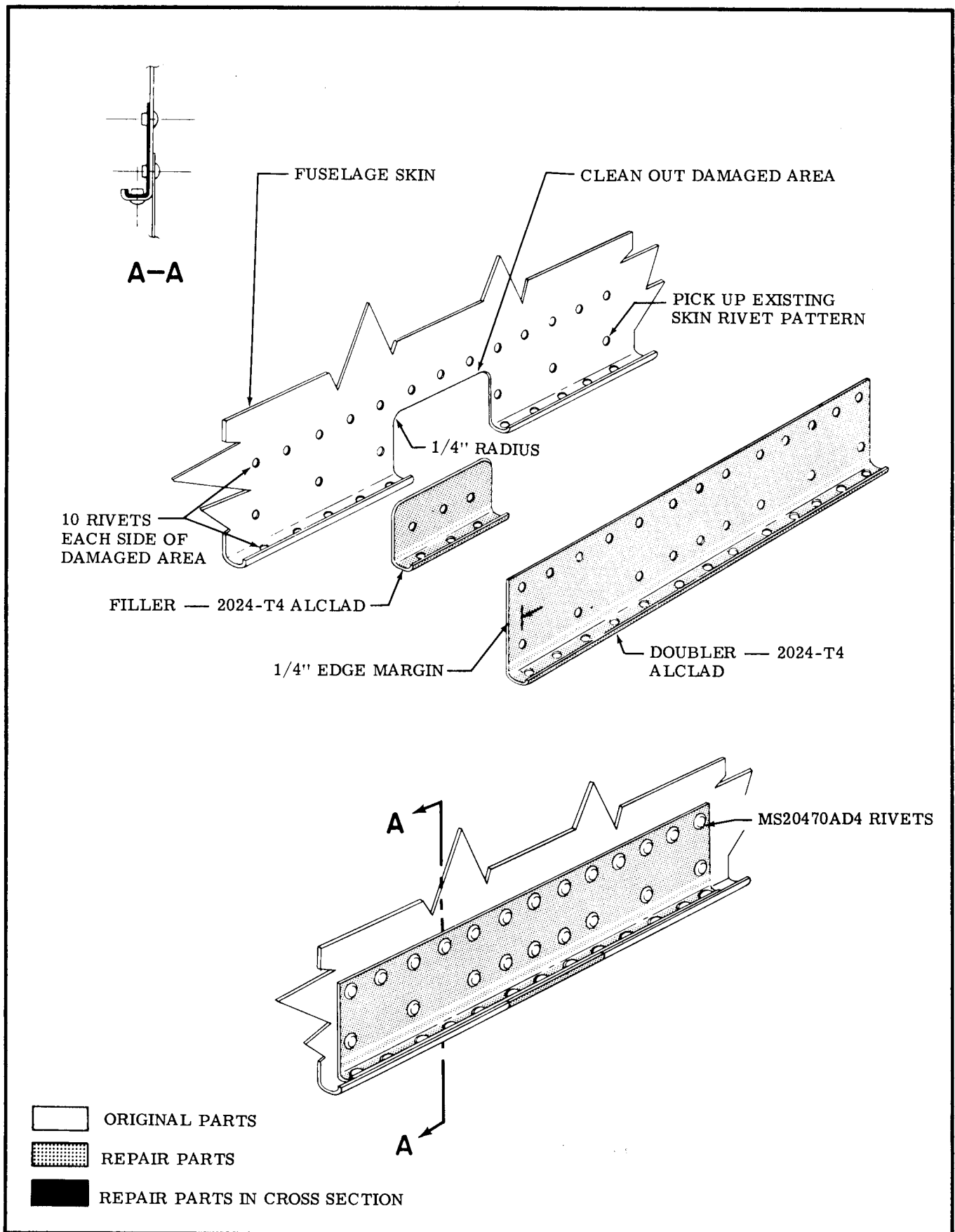
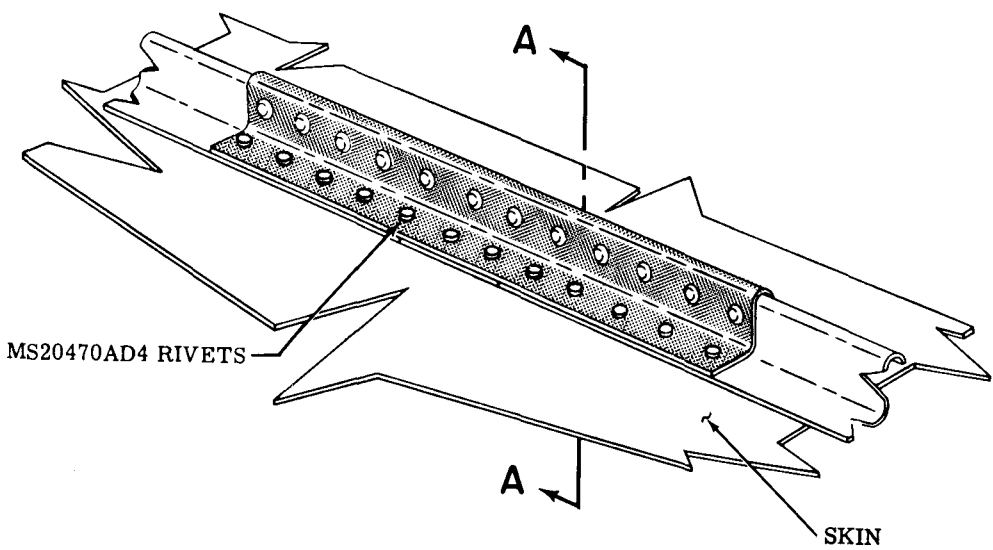
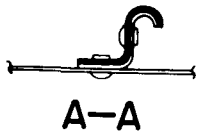
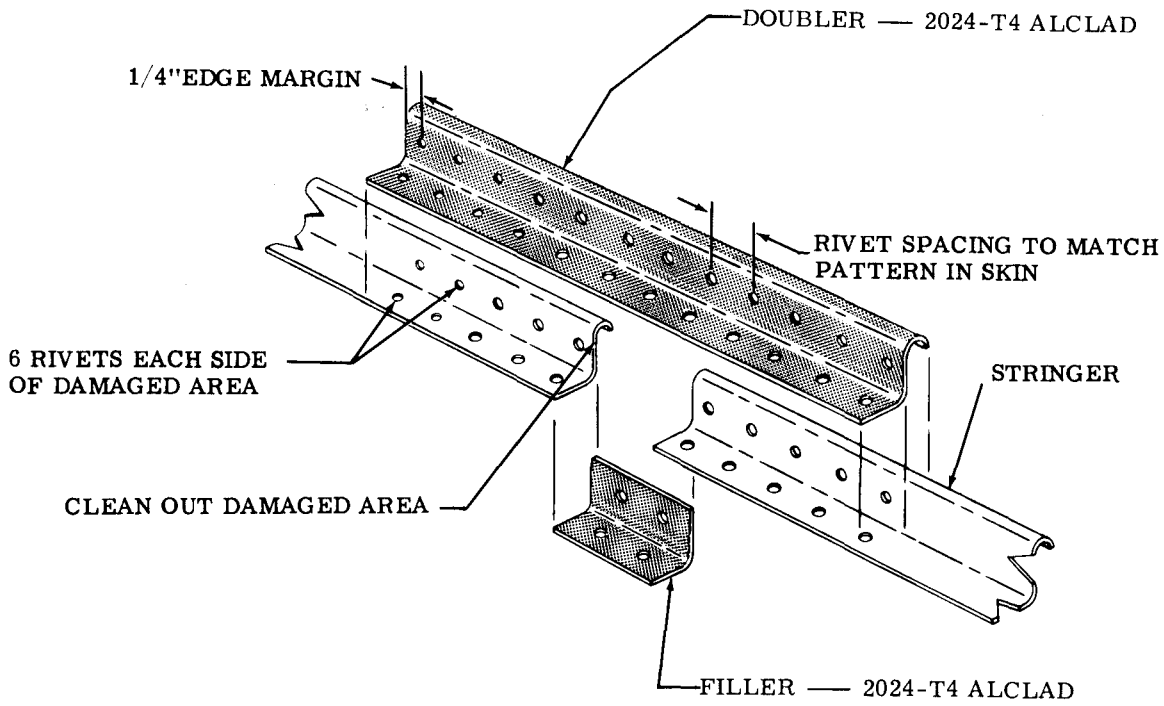

Figure 18-4. Skin Repair (Sheet 6 of 6)





-  ORIGINAL PARTS
-  REPAIR PARTS
-  REPAIR PARTS IN CROSS SECTION

Figure 18-5. Stringer and Channel Repair (Sheet 1 of 4)

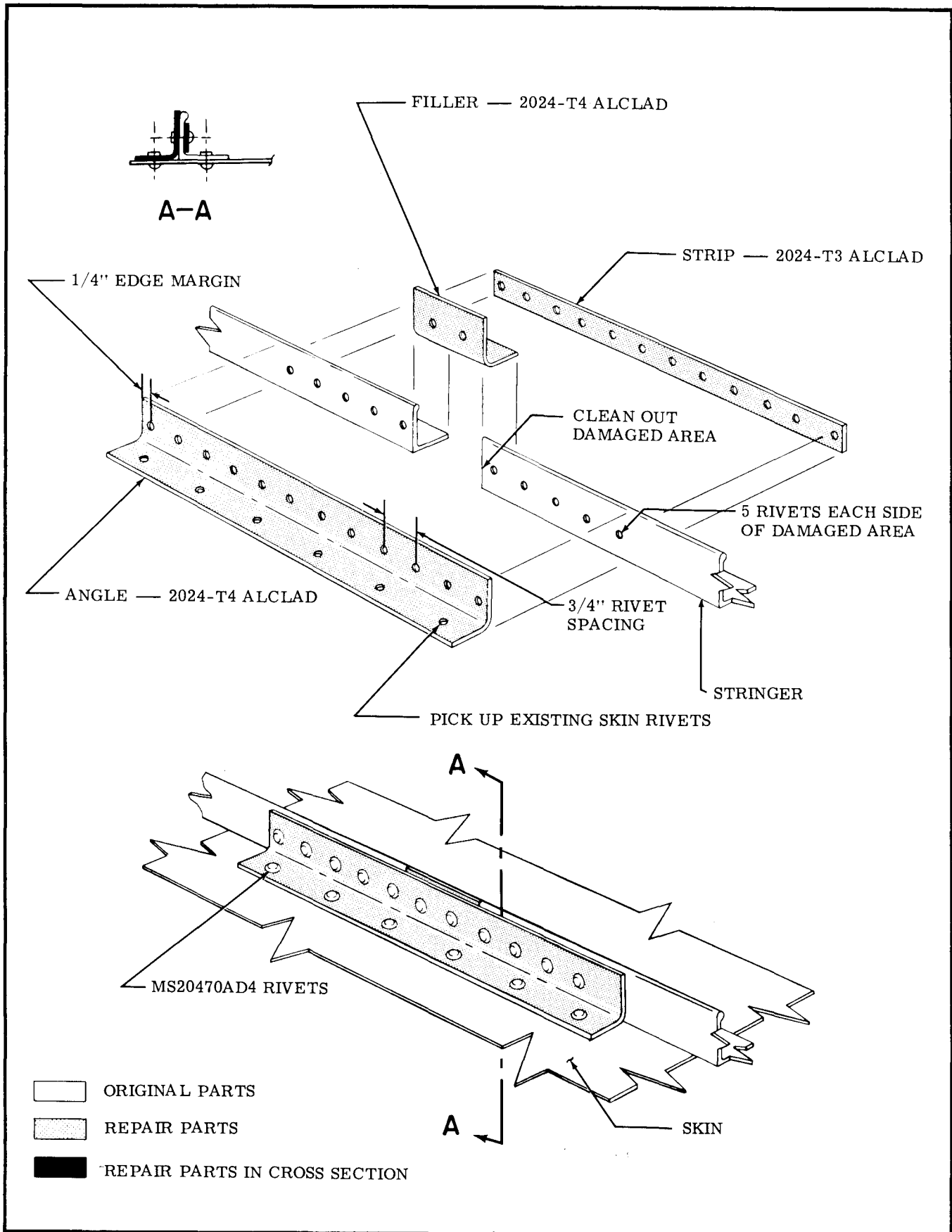
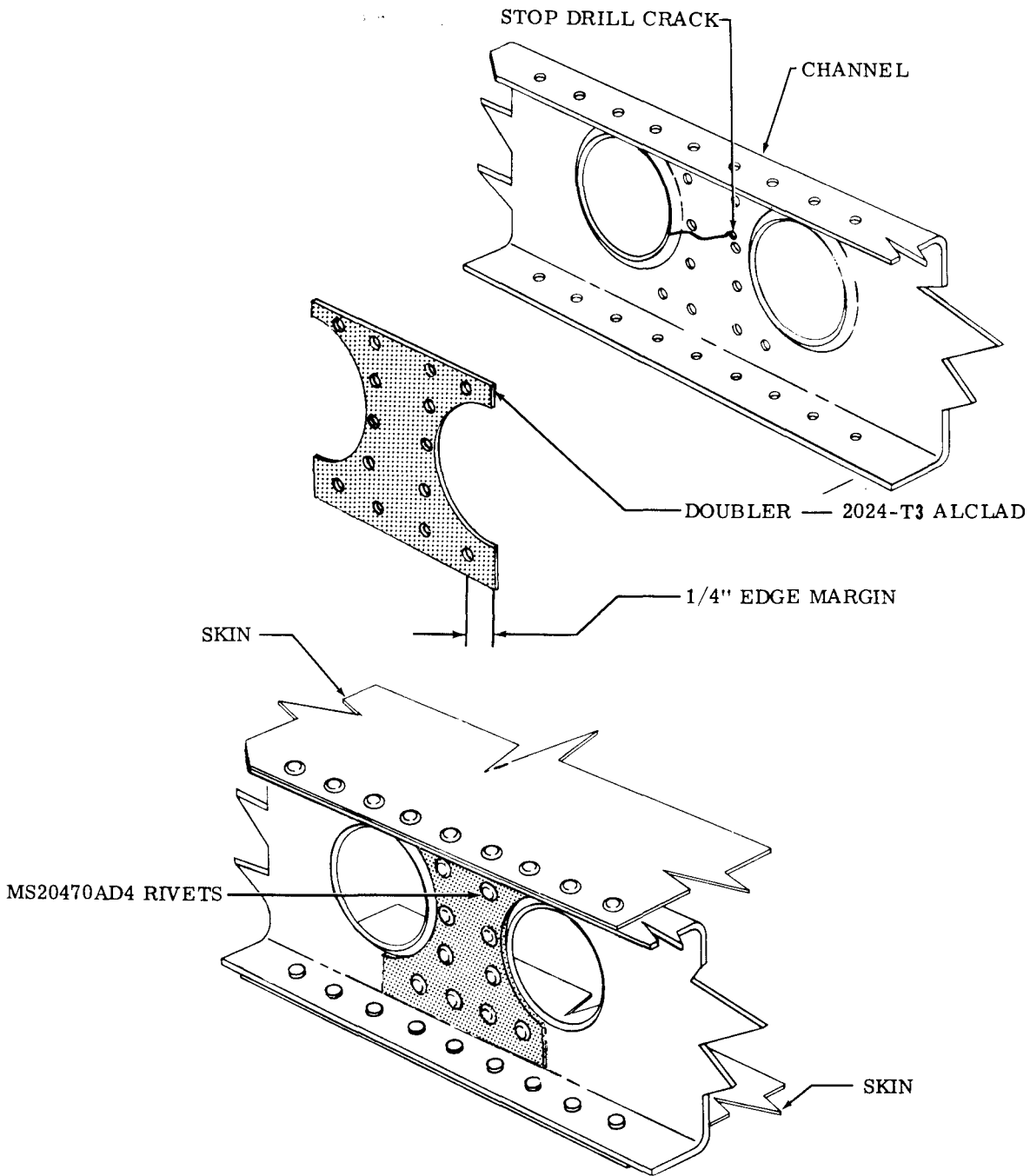

Figure 18-5. Stringer and Channel Repair (Sheet 2 of 4)



- ORIGINAL PARTS
- REPAIR PARTS
- REPAIR PARTS IN CROSS SECTION

Figure 18-5. Stringer and Channel Repair (Sheet 3 of 4)

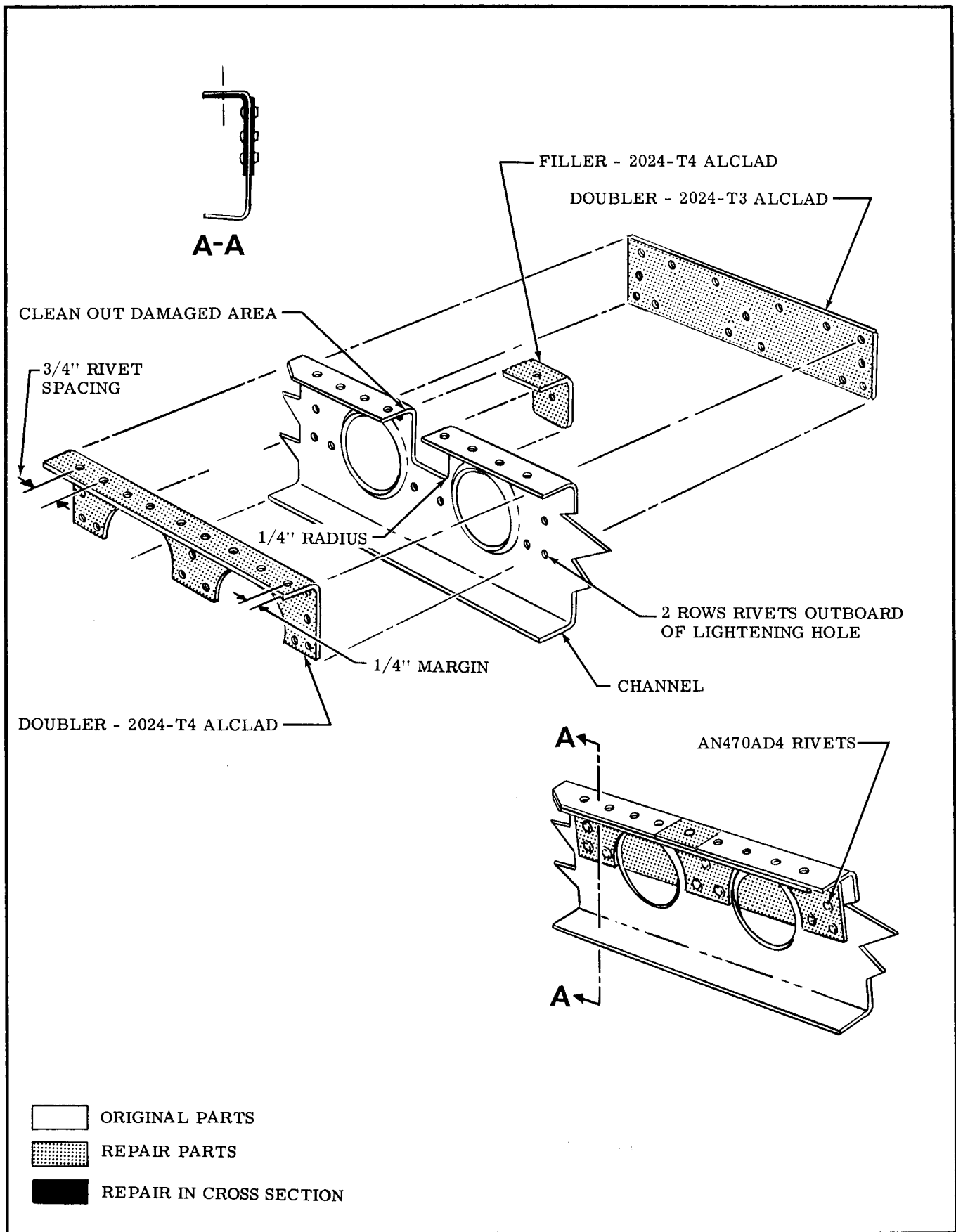

Figure 18-5. Stringer and Channel Repair (Sheet 4 of 4)

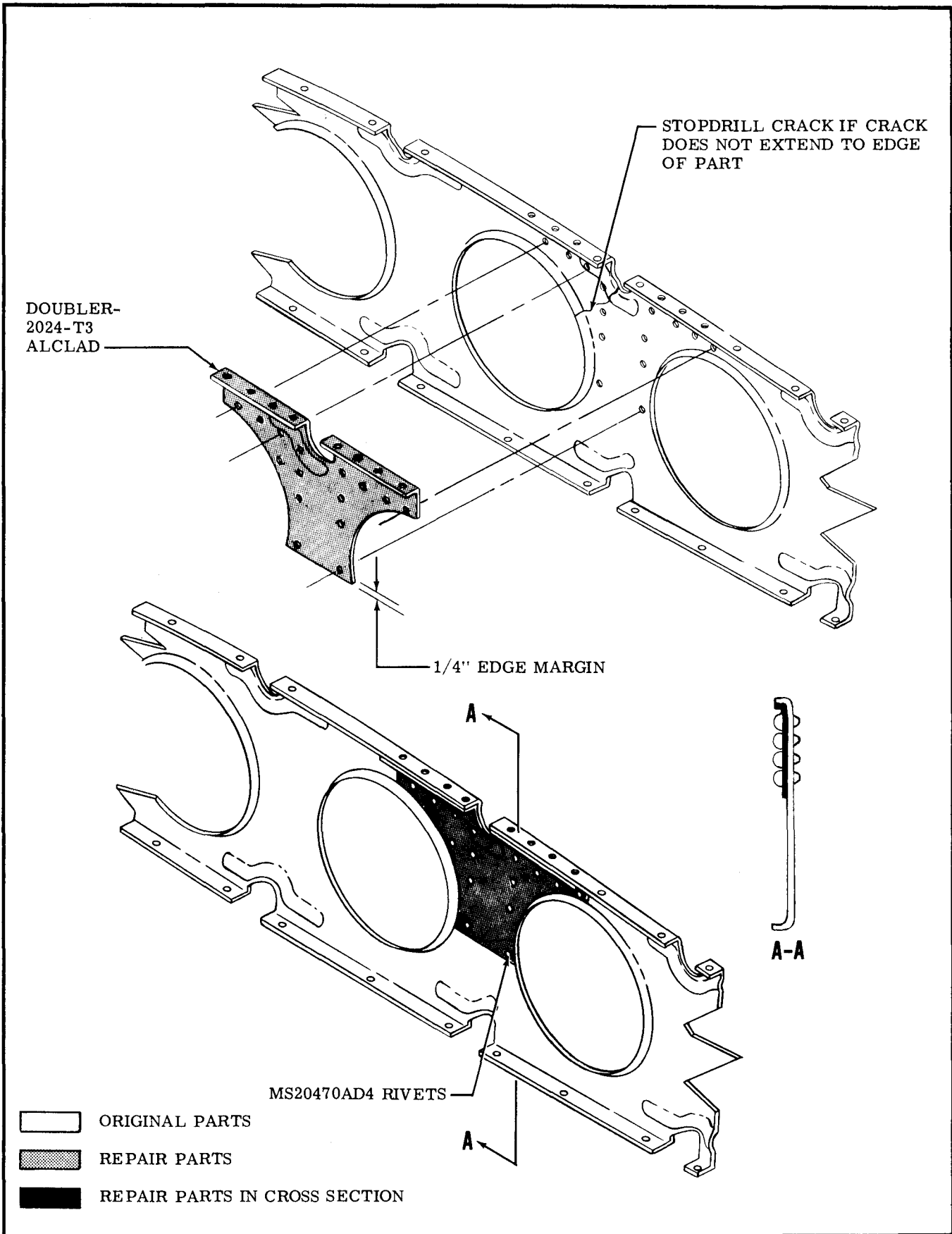

Figure 18-6. Rib Repair (Sheet 1 of 2)

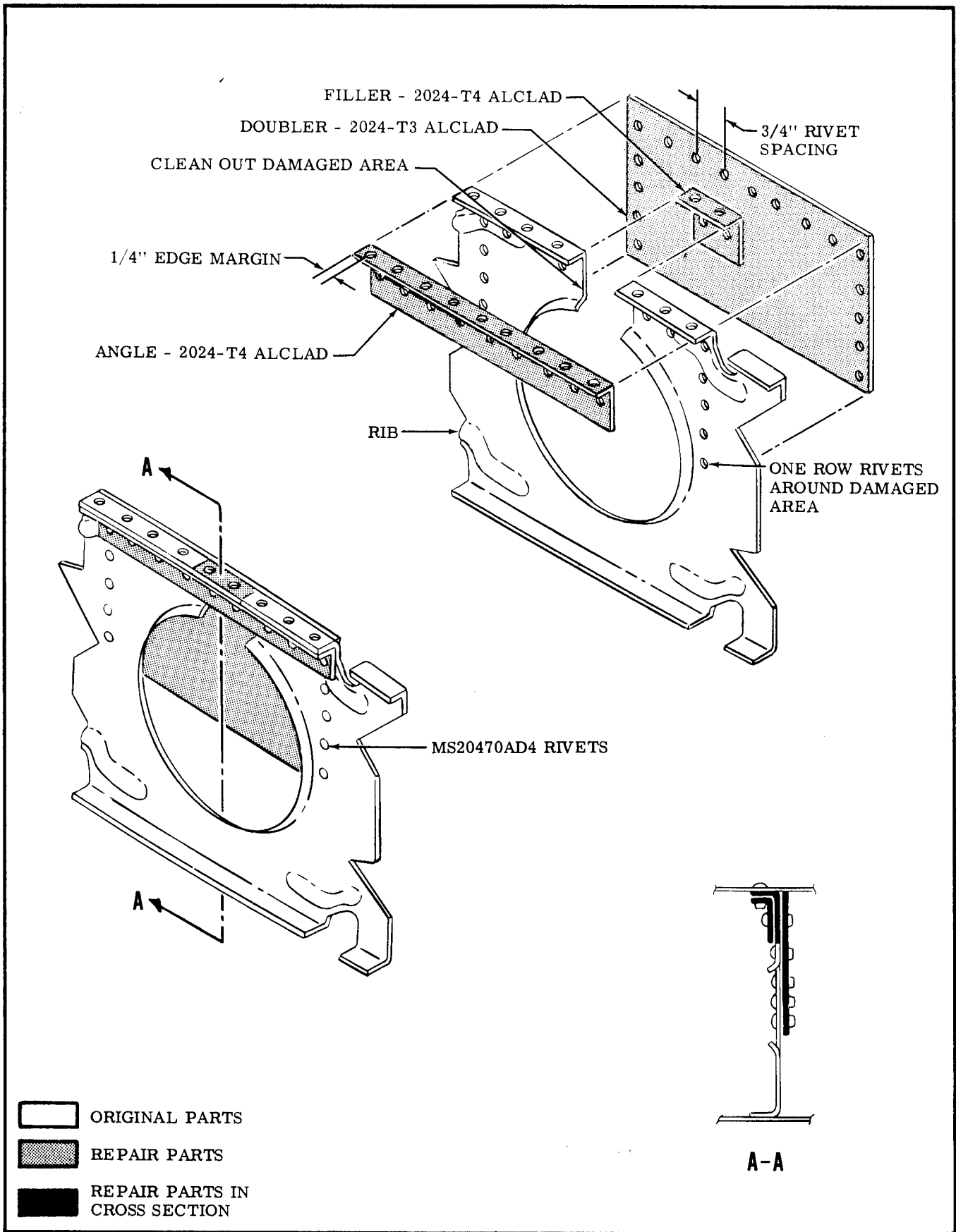

Figure 18-6. Rib Repair (Sheet 2 of 2)

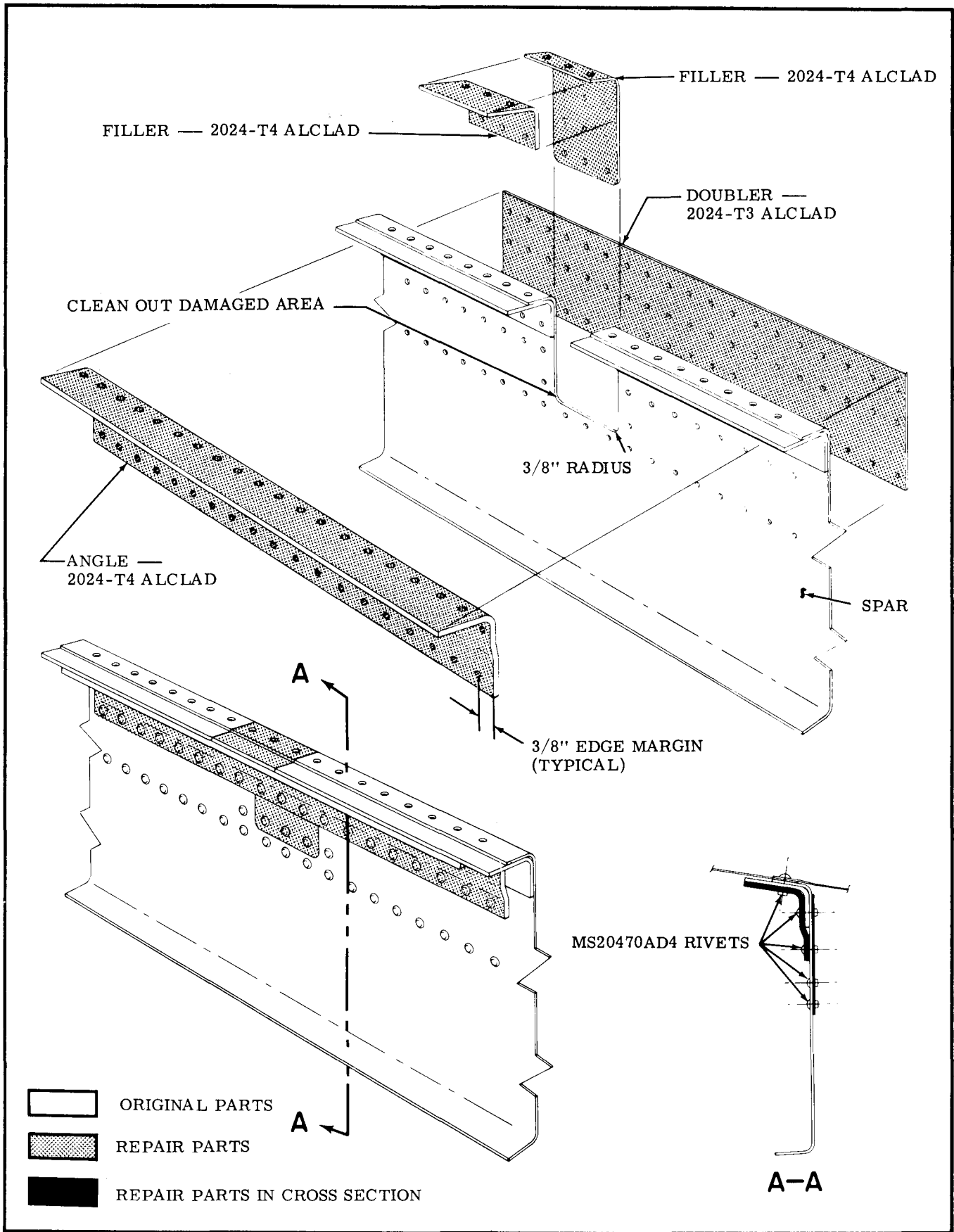

Figure 18-7. Wing Spar Repair (Sheet 1 of 3)

NOTE

This repair applies to either front or rear spar if the spar is a single channel.

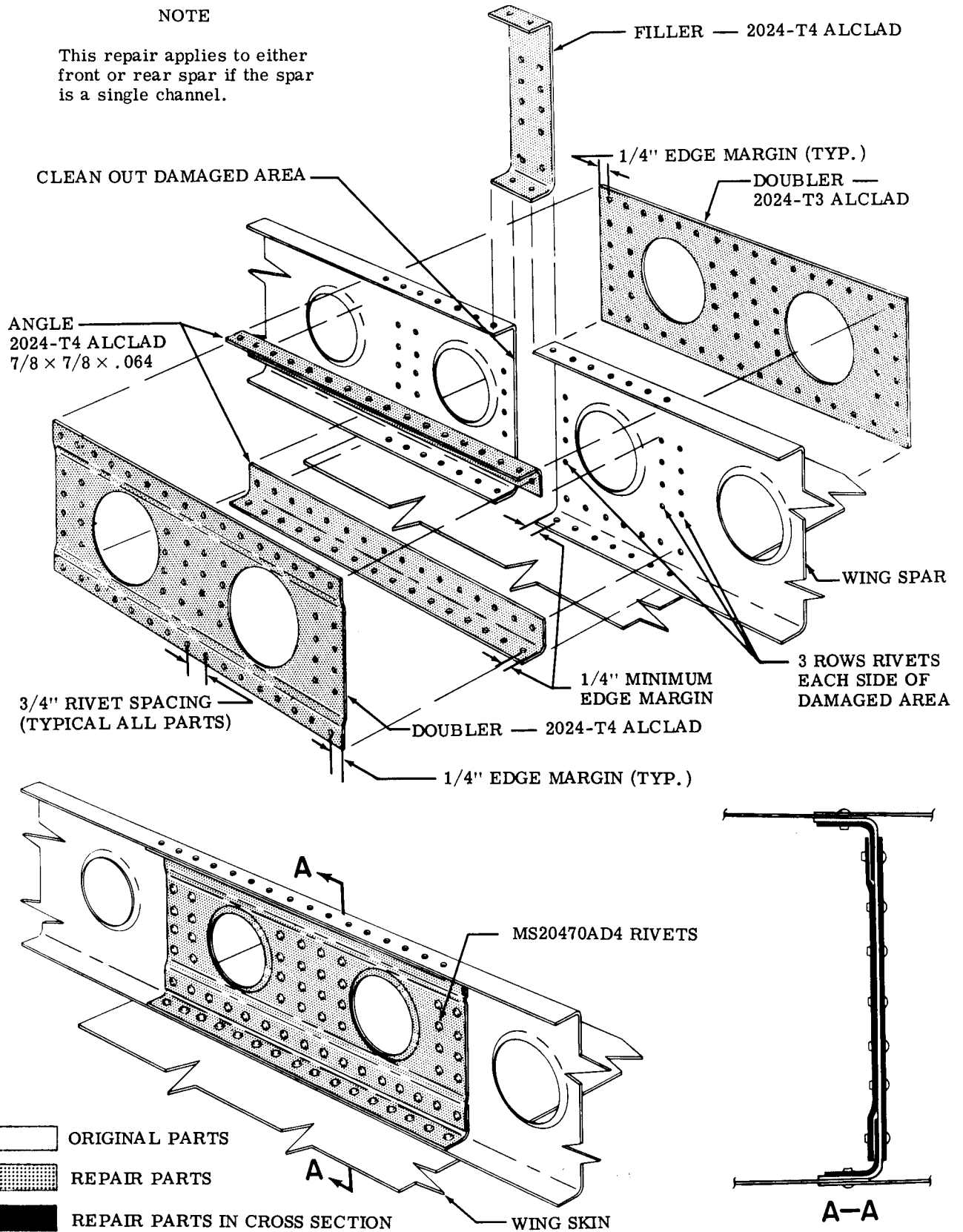

Figure 18-7. Wing Spar Repair (Sheet 2 of 3)

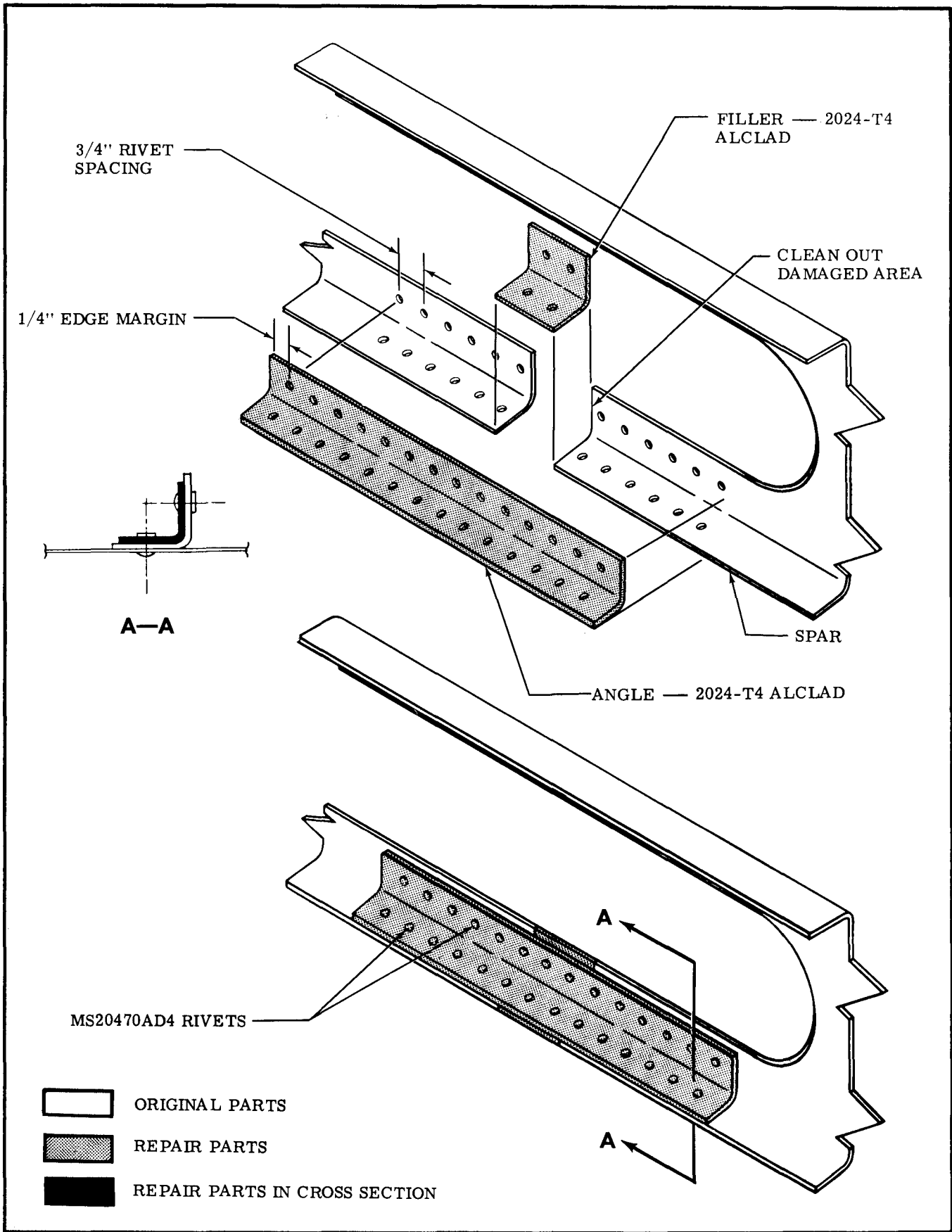

Figure 18-7. Wing Spar Repair (Sheet 3 of 3)

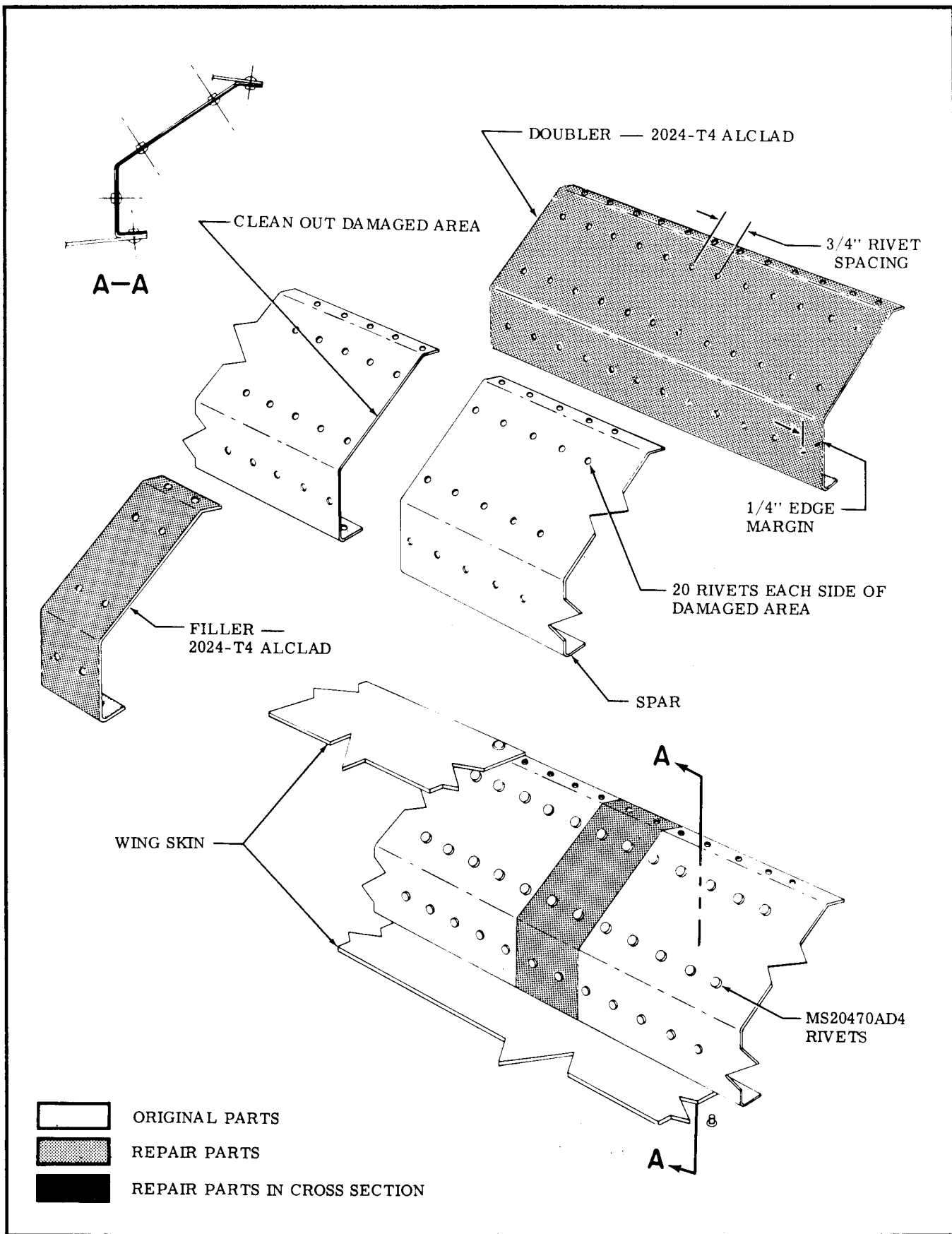

Figure 18-8. Auxiliary Spar Repair

NOTES:

1. Dimple leading edge skin and filler material; countersink the doubler.
2. Use MS20426AD4 rivets to install doubler.
3. Use MS20426AD4 rivets to install filler, except where bucking is impossible. Use CR162-4 Cherry (blind) rivets where regular rivets cannot be bucked.
4. Contour must be maintained; after repair has been completed, use epoxy filler as necessary and sand smooth before painting.
5. Vertical size is limited by ability to install doubler clear of front spar.
6. Lateral size is limited to seven inches across trimmed out area.
7. Number of repairs is limited to one in each bay.

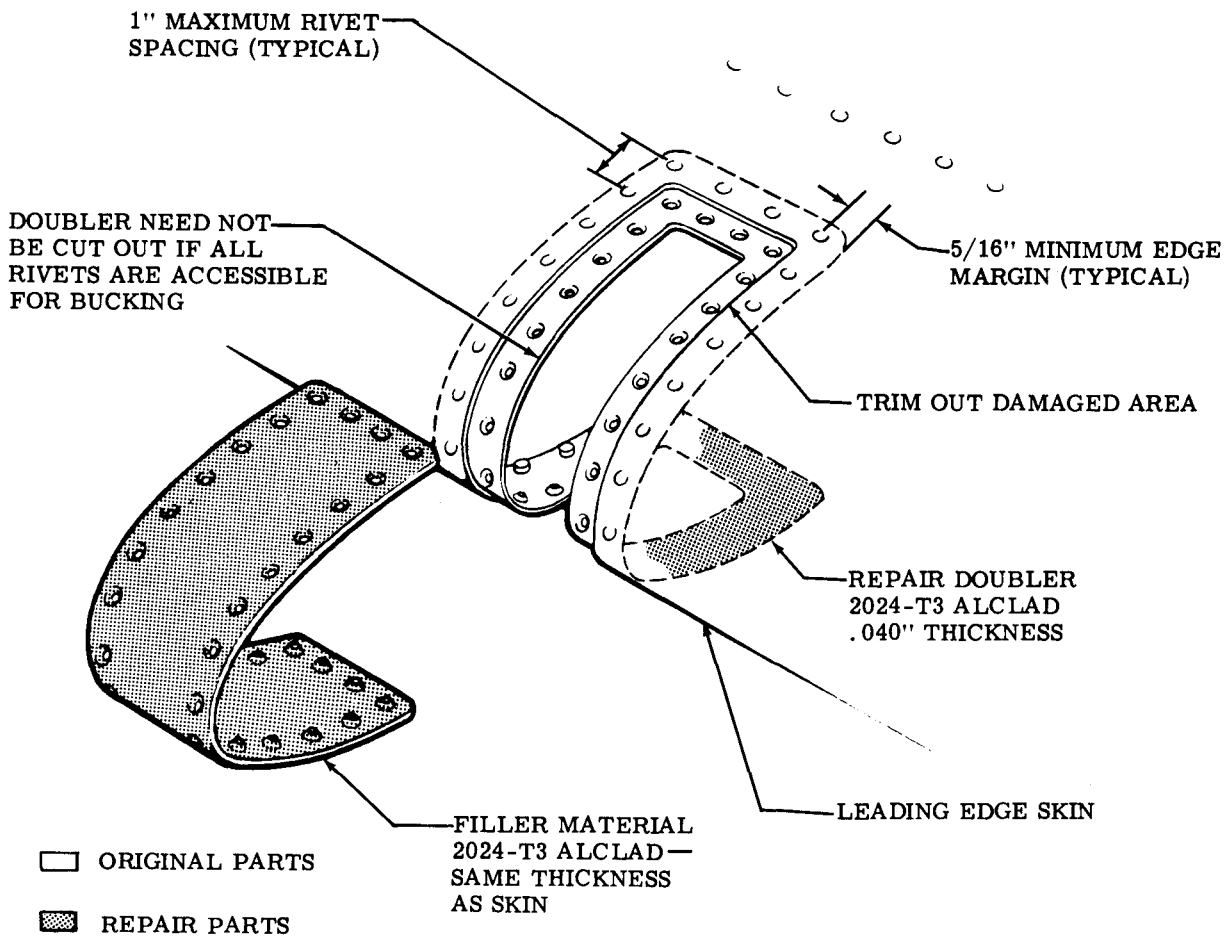

Figure 18-9. Leading Edge Repair

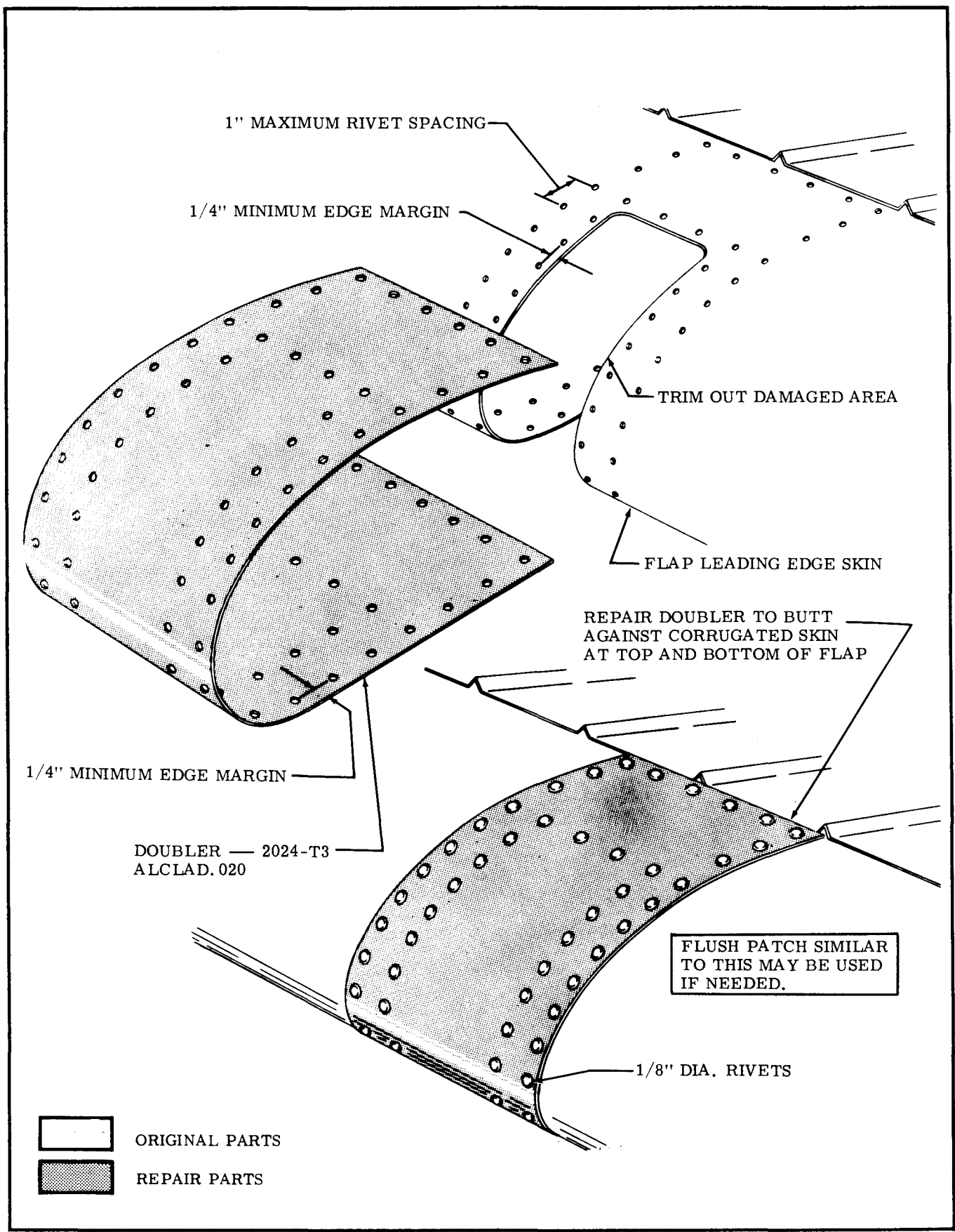
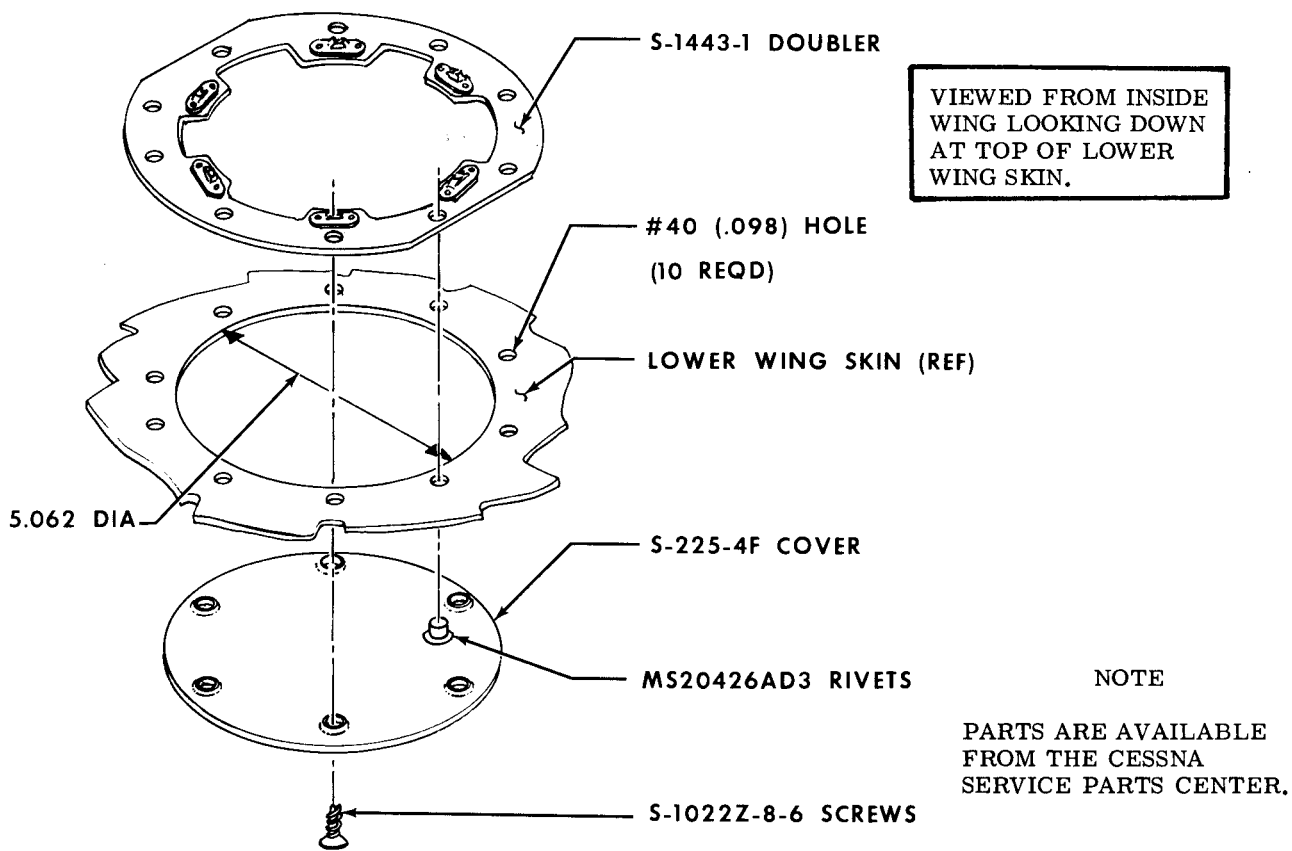

Figure 18-10. Flap Leading Edge Repair



PRECAUTIONS

1. Add the minimum number of access holes necessary.
2. Any circular or rectangular access hole which is used with approved optional equipment installations may be added in lieu of the access hole illustrated.
3. Use landing light installations instead of access holes (thru 1970 Models) where possible. Do not add access holes at outboard end of wing; remove wing tip instead.
4. Do not add an access hole in the same bay where one is already located.
5. Locate new access holes near the center of a bay (spanwise).
6. Locate new access holes forward of the front spars as close to the front spar as practicable.
7. Locate new access holes aft of the front spar between the first and second stringers aft of the spar. When installing the doubler, rotate it so the two straight edges are closest to the stringers.
8. Alternate bays, with new access holes staggered forward and aft of the front spar, are preferable.
9. A maximum of five new access holes in each wing is permissible; if more are required, contact the Cessna Service Department.
10. When a complete leading edge skin is being replaced, the wing should be supported in such a manner so that wing alignment is maintained.

- a. Establish exact location for inspection cover and inscribe centerlines.
- b. Determine position of doubler on wing skin and center over centerlines. Mark the ten rivet hole locations and drill to size shown.
- c. Cutout access hole, using dimension shown.
- d. Flex doubler and insert through access hole, and rivet in place.
- e. Position cover and secure, using screws as shown.

Figure 18-11. Access Hole Installation

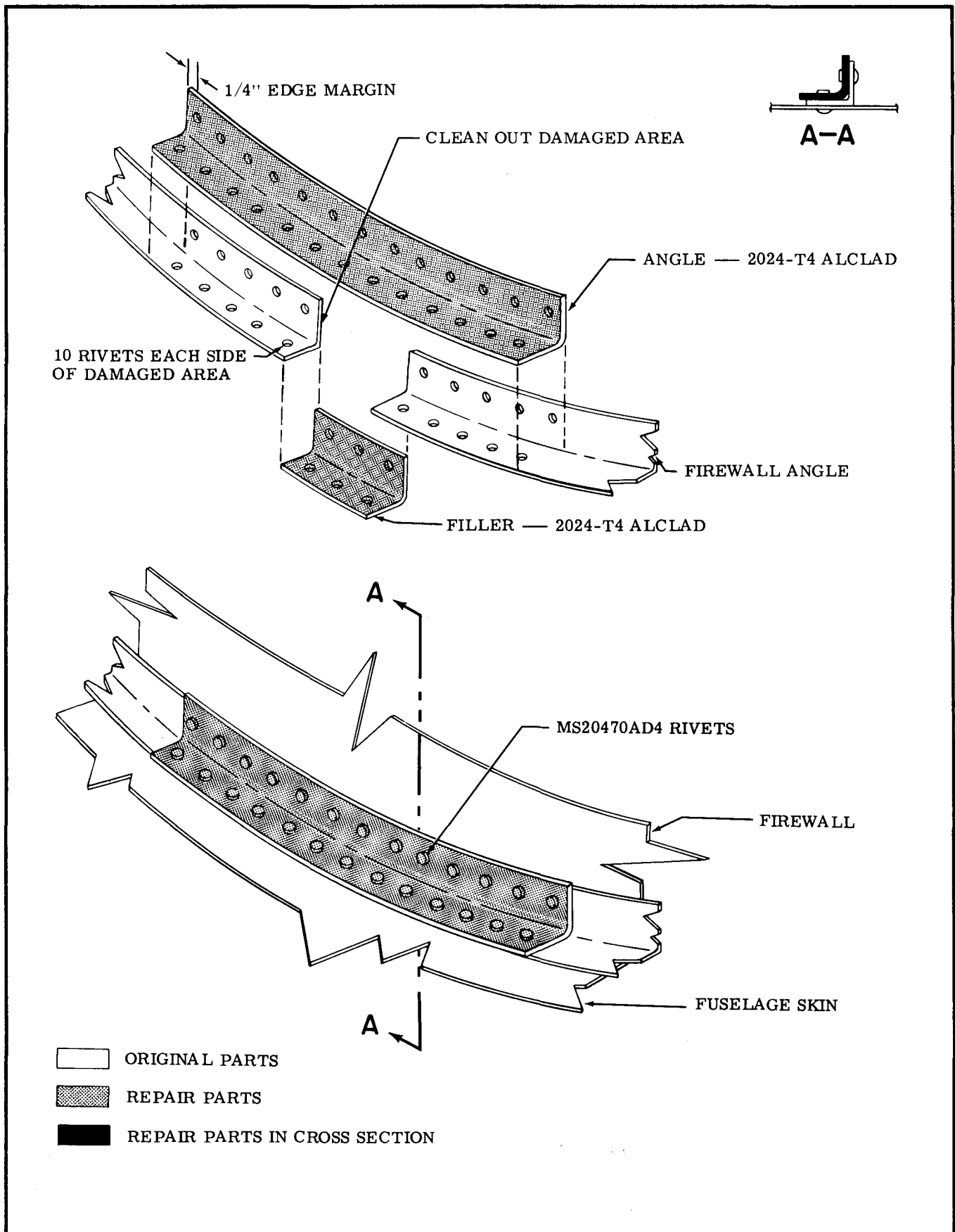

Figure 18-12. Firewall Angle Repair

This page intentionally left blank.

NOTE

This Section contains standard factory materials listing and area of application. For paint number and color, refer to Aircraft Trim Plate and Parts Catalog. In all cases determine the type of paint on the aircraft as some types of paint are not compatible. Materials may be obtained from the Cessna Service Parts Center.

MATERIAL	NO/TYPE	STANDARD THRU 1975	FRENCH STANDARD	TRAINER	COMMUTER AND COMMUTER II	FRENCH COMMUTER	AEROBAT	FRENCH AEROBAT	AREA OF APPLICATION
PAINT	ACRYLIC LACQUER	X		X	X		X		NOTE 1
PAINT	LACQUER		X			X		X	NOTE 1
PAINT	EPOXY	X	X	X	X				NOTE 2
PAINT	VINYL	X	X	X	X	X	X	X	NOTE 3
PRIMER	ER-7 WITH ER-4 ACTIVATOR	X	X	X	X	X	X	X	NOTE 4
PRIMER	P60G2 WITH R7K46 ACTIVATOR	X	X	X	X	X	X	X	NOTE 4
PRIMER	54-2385 AND 5400	X	X	X	X	X			NOTE 5
THINNER	T-6094A		X			X		X	NOTE 6
THINNER	T-8402A	X		X	X		X		NOTE 7
THINNER	T-3871	X	X	X	X	X			NOTE 8
THINNER	T-6487	X	X	X	X	X			NOTE 9
SOLVENT	#2 SOLVENT	X	X	X	X	X	X	X	NOTE 10
Refer to page 2 for notes.									

NOTES

1. Used on exterior airframe and main gear fairings, also nose gear fairing beginning with 1970 Models.
2. Used on nose gear fairing thru 1969 Models.
3. Used to paint inside door facing beginning with aircraft 15074710, A1500421, F15001014 and FA1500212.
4. Used with acrylic lacquer or lacquer on aluminum surfaces.
5. Used with epoxy paint.
6. Used to thin lacquer paint and for burndown.
7. Used to thin acrylic paint and for burndown.
8. Used with epoxy (Du Pont).
9. Used with epoxy (Enmar).
10. Used to clean aircraft exterior prior to priming.

NOTE

Do not paint Pitot Tube, Gas Caps or Antenna covers which were not painted at the factory.

CAUTION

When stripping paint from the aircraft, avoid stripper coming in contact with ABS parts. These areas should be cleaned with soap and water and/or Naphtha. Do not use strong solvents such as Xylol, Toluol, or Lacquer Thinners. Once clean, exterior ABS parts are ready for the acrylic lacquer topcoat. Do Not wash prime ABS parts.

SECTION 20
WIRING DIAGRAMS

TABLE OF CONTENTS Page

D. C. POWER (THRU 1975 MODELS)

60-Ampere Ammeter	20-2
Circuit Breaker, Fuse & Bus Bar Wiring	20-3
Ground Service Receptacle	20-4
60-Ampere Alternator	20-5
60-Ampere Alternator	20-6
60-Ampere Alternator	20-7
60-Ampere Alternator	20-8
Bus Bar, Circuit Breaker & Fuse	20-9

IGNITION

Magnetos	20-10
--------------------	-------

ENGINE CONTROL

Contactor and Starter	20-11
Starter	20-12

ENGINE INSTRUMENTS

Fuel Indicator and Transmitter	20-13
Hourmeter	20-14

FLIGHT INSTRUMENTS

Turn and Bank Indicator	20-15
Pictorial Gyro	20-16
Turn Coordinator	20-17
Wing Leveler	20-18
Encoding Altimeter	20-19

D. C. POWER (BEGINNING WITH 1976 MODELS).

60-Ampere Ammeter	20-39
Circuit Breaker, & Bus Bar	20-41
Ground Service Receptacle	20-42
60-Ampere Alternator	20-40

IGNITION

Magnetos	20-43
--------------------	-------

ENGINE CONTROL

Contactor and Starter	20-44
Starter	20-45

ENGINE INSTRUMENTS

Fuel Indicator and Transmitter	20-46
Hourmeter	20-47

FLIGHT INSTRUMENTS

Turn and Bank Indicator	20-48
Turn Coordinator	20-49
Encoding Altimeter	20-50

MISCELLANEOUS INSTRUMENTS

Clock	20-20
-----------------	-------

LIGHTING

Dome Lights	20-21
Instrument Lights	20-22
Instrument Lights	20-23
Landing and Taxi Lights	20-24
Landing Light	20-25
Landing and Taxi Lights	20-26
Navigation Lights	20-27
Flashing Beacon Light	20-28
Flashing Beacon Light	20-29
Map Light, Control Wheel	20-30
Map Light, Control Wheel	20-31
Strobe Light	20-32
Strobe Light	20-33

HEATING, VENTILATING AND DE-ICING

Cigar Lighter	20-34
Cigar Lighter	20-35
Pitot Heater	20-36

CONTROL SURFACES

Wing Flaps, Electric	20-37
Wing Flaps, Electric	20-38

MISCELLANEOUS INSTRUMENTS

Clock	20-51
-----------------	-------

LIGHTING

Dome Lights	20-52
Instrument Lights	20-53
Landing and Taxi Lights	20-54
Navigation Lights	20-55
Flashing Beacon Light	20-56
Map Light, Control Wheel	20-57
Strobe Light	20-58

HEATING, VENTILATING AND DE-ICING

Cigar Lighter	20-59
Pitot Heater	20-60

CONTROL SURFACES

Wing Flaps, Electric	20-61
--------------------------------	-------

SER 15064533 & ON

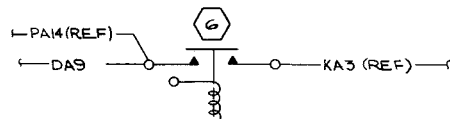

DETAIL B
SER 15069309 THRU SER 15070970

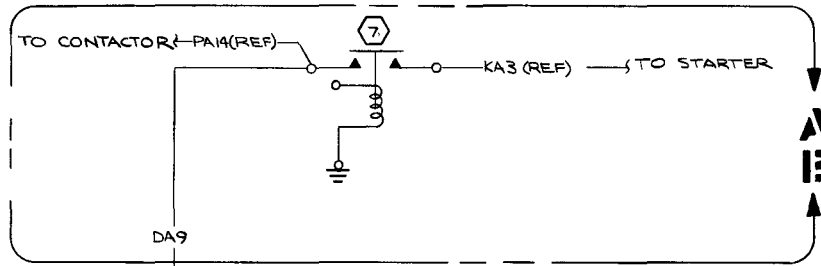

DETAIL A
THRU SER 15069308

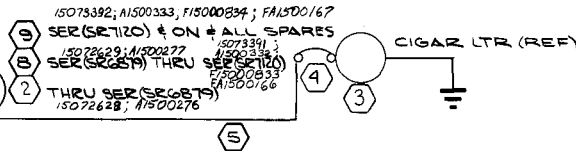

DETAIL C
THRU SER 15072003 & SER A15000226

ITEM NO	PART NO.	DESCRIPTION	INSTALLED ON
9	S-1320-5	AMMETER	
8	S-1320-3	AMMETER	
7	S-1991-1	CONTACTOR	
6	S-1660-4	CONTACTOR	
5	0513039-5	WIRE ASSY.	
4	60232-1	CIRCUIT BREAKER (15472)	
3	0513052-3	LIGHTER ASSY.	
2	S-1320-1	AMMETER	
1	S-1596-60L	CIRCUIT BREAKER	

EQUIPMENT TABLE

CHG LET	REVISION	BY DATE	CHK APPD
A	BY REV: ON DAB S-1367-4-14 WAS S-1367-4-10, ADD CIGAR LTR (REF) ON BUS BAR GEN WAS ALT; ADD 0513052-3; 0513039-5 & 60232-1 E/T (15065042)	9/28/74	YAK RLY
B	BY REV: ADD DETAIL A & SER; SER OUT DAB ED&RR 02332 (SR5437) IX	4-8-68	GK1 MDS RLY
C	BY REV: ADD DETAIL B, S-1991-1 & SR. ED&RR 10474 (SR6222)	5-23-68	MDS RLY
D	BY REV: ADD DETAIL "C", DA10 & SER ED&RR 10021 (SR6350) (SR6351) IX	4-29-70	DLP RLY
E	BY REV: SER OUT S-1320-1, SER IN S-1320-3; SER OUT S-1320-3, SER IN S-1320-5 (SR6879) (SR7120)	2-28-72	RLY RLY
F	BY REV: ADD WIRE LENGTHS S1367-4-14 PER DA9 WAS S1367-6-13 NOW SHOP PRACTICE	4-9-73	DLO RLY

INACTIVE
EFF THRU SER(SR7900)(SR7901)(SR7902)
S-15-74
BRF (15077009, A1500614)
RFL

500-522-00

WIRE NO.	GA	MATERIAL	LG	TERMINALS	SERIALS
DA10	8		5	S-1367-4-10	S-1367-4-10
DA9	8		79	S-1367-4-10	S-1367-4-14
DAB	8			S-1367-4-10	S-1367-4-14
DAT	8		35	S-1367-4-10	S-1367-4-10

WIRE TABLE

CESSNA AIRCRAFT CO., COMMERCIAL AIRCRAFT DIVISION, WICHITA, KANSAS

DRAWN	BLISS	DATE	10-8-65	TITLE	WIRING DIAGRAM—
GROUP	H. Wier	DATE	10-29-65		AMMETER
CHECK	R. Stuck	DATE	10-30-65		60 AMP
PROJ	R. Stuck	DATE	11-2-65		

DWG NO: 0410011

SUPERSEDED BY: 0470401 Pg. 4.1 | SUPERSEDES: 041011 Pg. 4.3 | MODEL: 150 | REV: F | PAGE: 4.8

NOTE:

1. THIS DWG IS FOR REF. PURPOSES ONLY. FOR WIRE & TERMINAL REQUIREMENTS AND WIRING DIAGRAMS SEE THE INDIVIDUAL PAGES OF 0410011.

(SR4920)

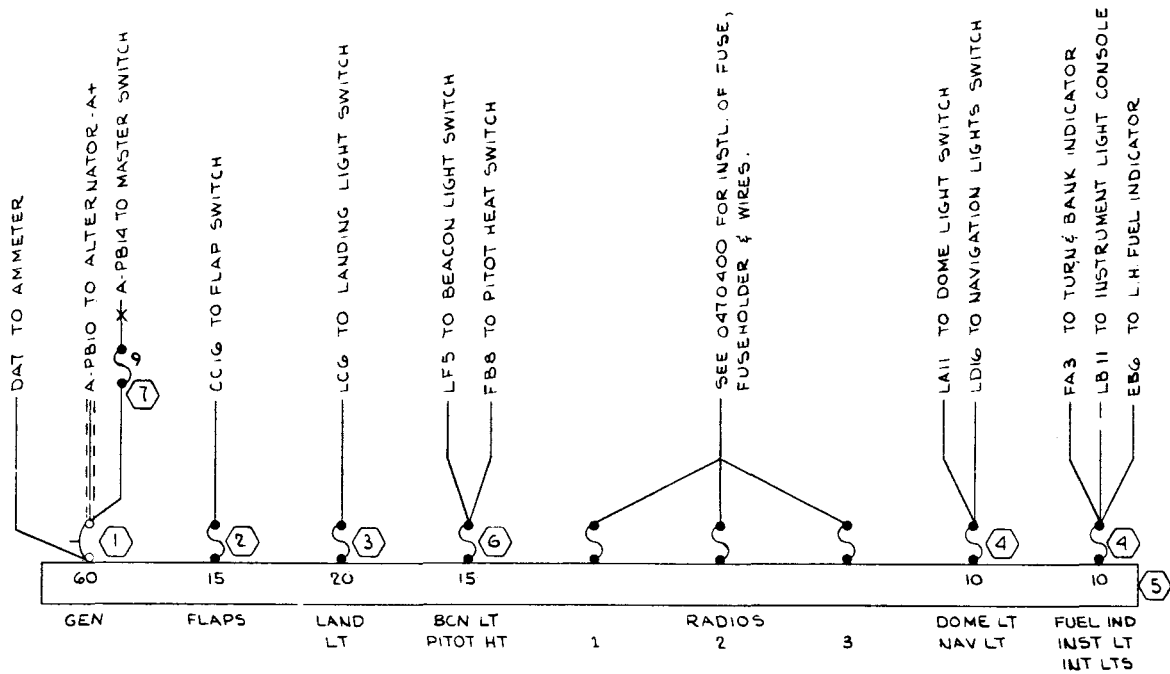

CHG LET	REVISION	BY	DATE	CHK
A	BY REV. ON BUS BAR GEN WAS ALT. BCN LT WAS NOT BCN, DOME LT NAV LT V REG WAS NAVLTS-CIGAR LITE; FUEL IND INST LT-INT LTS WAS INT LTS -INST; TO BEACON - INT SWITCH WAS TO ROTATING BEACON SWITCH, DELETED NC1 TO CIGAR LIGHTER FROM DOME LT FUSE; ADD S-1091-15 TO BEIT; S-1707-60 WAS S-1596-60, BCN LT FUSE S-1091-15 WAS S-1091-10 (SR5753)	8978	7-20-66	YAK RUB DOK AD
B	BY REV. ON BUS BAR DOME LT-NAV LT WAS DOME LT-NAV LT-V REG; ADD PB14 TO FLD; ADD HRH TO EIT (SR5799)	8978	9-10-66	YAK RUB DOK AD
C	BY REV: S-1596-60 WAS S-1707-60 (SR5437)	SEM	4-18-68	SEM RUB DOK AD

INACTIVE:
LEFT THRU SER 15072003 AND
RIGHT THRU SER A15000226
EDR 10021 4-19-70

7	HRH	FUSEHOLDER ASSY (BUS)
6	S-1091-15	FUSE
5	0470016-1	BUS BAR
4	S-1091-10	FUSE
3	S-1091-20	FUSE
2	S-1627-15	FUSE
1	S-1596-60	CIRCUIT BREAKER

PART NO.	DESCRIPTION	INSTALLED ON

EQUIPMENT TABLE

WIRE CODE NO.	GA	MATERIAL	LG	TERMINALS	SERIALS

WIRE TABLE			
CESSNA AIRCRAFT CO. COMMERCIAL AIRCRAFT DIVISION, WICHITA, KANSAS			
DRAWN	BLISS	DATE	10-8-65
GROUP	H. W. W.	DATE	10-29-65
CHECK	S. STUCK	DATE	11-2-65
PROJ	11-2-65		
NAME		TITLE	
WIRING DIAGRAM -		CIRCUIT BREAKER,	
FUSE & BUS BAR		WIRING	
SUPERSEDED BY	P 4-14	SUPERSEDES	0410011 PG 4.4
MODEL:	150	REV:	C
PAGE:	4.9	DWG NO.:	0410011



REVISION			
LET	DESCRIPTION	DATE	APPD
A	BY REV: SER OUT S-1579-1 & ADD S-1579-2 (SR7201)	BPH 7-26-72	LW RF
B	BY REV: ADD WIRE LENGTHS (NOW SHOP PRACTICE)	DLO 3-15-73	LW RF
C	BY REV: ADD WIRE COLORS, GRN(PC2) WAS PC2; YEL(PC3) WAS PC3; LG18 WAS 10/PC2 & PC3 MER 150-E0044 (SR 7600) ^(X) (REF)	JEF 5-13-74 BRF	LW RF

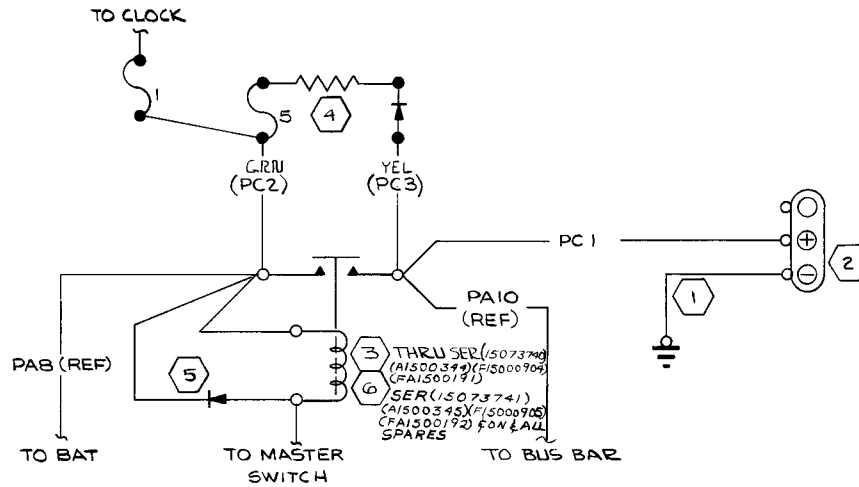

INACTIVE
EFF THRU SER(SR7900)(SR7901)(SR7902)
8-15-74
BRF (150770000, A1500614)
JEF
BRF
5-13-74
RF

5060-622-00

WIRE CODE NO.	GA	MATERIAL	LG	TERMINALS	SERIALS
YEL (15073)	18		18	5-1361-1-13	SOLDER
BRN (15072)	18		18	5-1361-1-13	SOLDER
PC1	4		30	5-1361-6-13	5-1361-6-14

ITEM NO.	PART NO.	DESCRIPTION	VENDOR
6	S-1579-2	CONTACTOR	
5	F4	DIODE	(84970)
4	0712031-3	FUSE & DIODE ASSY	
3	S-1579-1	BAT. CONTACTOR	
2	AN2552-3A	RECEPTACLE	
1	0312155-10	GND STRAP	

SUPERSEDES:
 SUPERSEDED BY:
 0470401 P6 4.4

CES-1000 IS APPLICABLE
 VENDOR CODES PER S-1400
 CES-XXXX-CESSNA SPEC. NO.
 S-XXX OR CMXXXX-CESSNA
 STD. NO.

CONTRACT NO:			COMMERCIAL AIRCRAFT DIV. 5800 E. PAWNEE WICHITA, KANSAS		
DESIGN	NAME	DATE	TITLE		
	COOK	11-27-67	WIRING DIAGRAM -		
GROUP	H. WIND	11-27-67	GROUND SERVICE RECEPTACLE		
DRAWN	HARRIS	11-20-67	(OPT)		
CHECK	LAURIE	11-21-67			
STRESS	WECHINGSON	11-27-67			
PROJECT	D. G. KULLER	11-27-67	SIZE	CODE IDENT. NO.	DWG NO.
APPD	J. S. MARTEN	11-22-67	C	71379	0410011
SCALE: NONE			150	PAGE: 4.11	

(SR5437) ED & RR 00938
1506309
F500390

REVISION			
LET	DESCRIPTION	DATE	APPD
A	BY REV: ADD PIN '7' TO ITEMS 5 & 6 IN FIELD, PB10 (REF) WAS PB30, S-1596-60 WAS S-1707-60 ED&RR 01990 (SR5437) IX	3-27-66	GKI MDS R.W. J.W. D.W.

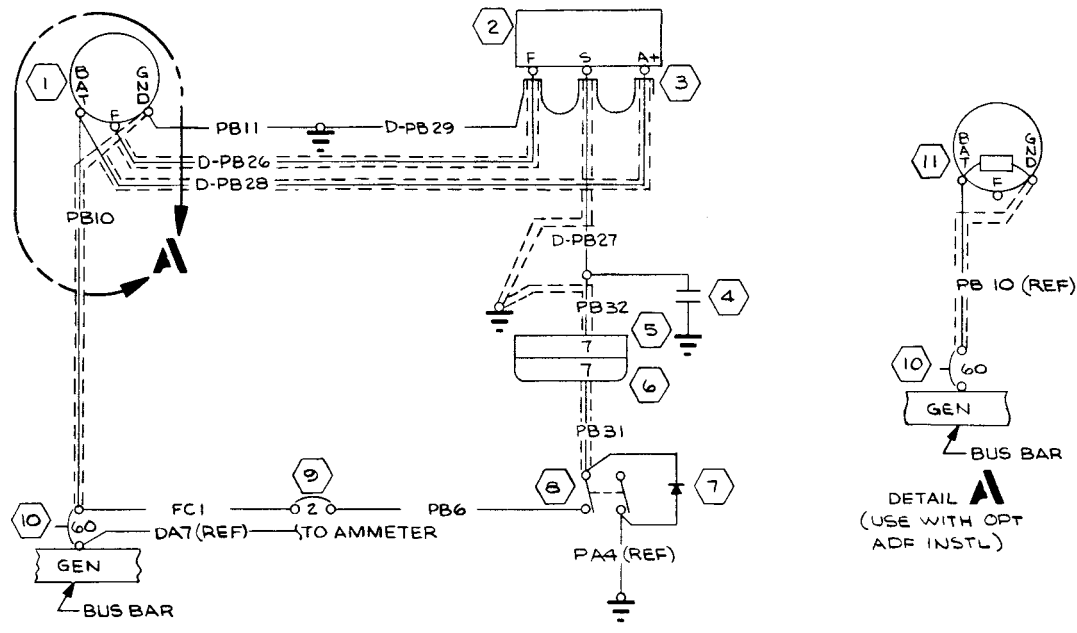

INACTIVE:
EFF SER 15069309 &
SER F150-0390
THRU SER 15071128
FER UNW R.W. J.W. ED&RR 10/21
MOS 7/10

NOTES:

- 1. TERMINAL 42281-2 (00779) ON CONDUCTOR. TERMINAL 2-323931-2 (00779) ON SHIELD & GND WIRE
- 2. WIRE MATERIAL PER S-1534-8-9.
- 3. OBSERVE POLARITY SYMBOL ON DIODE WHEN INSTALLING ON SW TERM OR DIODE WILL FAIL WHEN SYSTEM IS ENERGIZED.
- 4. 'D' PREFIX IS USE BECAUSE THESE WIRES ARE ALSO IN 0770750

ITEM NO	PART NO.	DESCRIPTION	VENDOR
11	1250209-1	NOISE FILTER ASSY	
10	S-1596-60	CIRCUIT BREAKER	
9	CA2	CIRCUIT BREAKER (80602)	
8	S-1159-1	MASTER SWITCH	
7	0770719-1	DIODE ASSY	
6	S-1640-9	HOUSING-PIN	
5	S-1641-9	HOUSING-SOCKET	
4	0770038-2	FILTER	
3	C6AB-10A730-A	HOUSING (88690)	
2	C611001-0101	REGULATOR	
1	C611501-0201	ALTERNATOR ASSY	

EQUIPMENT TABLE		
PART NO.	DESCRIPTION	VENDOR
CES-1000	IS APPLICABLE	
VENDOR CODES	PER S-1400	
CES-XXXX	-CESSNA SPEC. NO.	
S-XXX	OR CMXXXX	-CESSNA STD. NO.

SUPERSEDES:	
0410011	P 4.10
SUPERSEDED BY:	
P 4.13	

WIRE CODE NO.	GA	MATERIAL	LG	TERMINALS	SERIALS
D-PB29	18			S-1367-1-12	
D-PB28	185			S-1367-1-12 S-1367-2-10	
D-PB27	185			S-1367-1-4 S-1367-2-8	
D-PB26	185			S-1367-1-10 S-1367-2-10	
PB31	185			S-1367-1-8	S-1635-2
PB11	10			S-1367-3-10	S-1367-3-12
PB10	85			S-1367-4-12	S-1367-4-10
PB32	185			S-1367-3-10	S-1367-1-10
PB6	16			S-1636-2	S-1367-2-8
FC1	16			S-1367-4-10	S-1367-4-10

CONTRACT NO:			WIRE TABLE		
DESIGN	NAME	DATE	DESIGN	NAME	DATE
W	COOK	12-18-67			
GROUP	H. W.	12-18-67			
DRAWN	HARRIS	12-12-67			
CHECK	LAURIE	12-14-67			
STRESS					

COMMERCIAL AIRCRAFT DIV. 5800 E. PAWNEE WICHITA, KANSAS		
Cessna AIRCRAFT CO.		
TITLE		
WIRING DIAGRAM - ALTERNATOR SYSTEM, 60AMP		
PROJECT	APPD	DATE
D.C. Kille	MARTEA	12-20-67
SIZE	CODE IDENT. NO.	DWG NO.
C	71379	0410011
SCALE:	NONE	150
PAGE:	4.12	

Change 3 20-5

REVISION				REVISION			
LET	DESCRIPTION	DATE	APPD	LET	DESCRIPTION	DATE	APPD
G	BY REV: S-1493-2 WAS S-1493-1/PB6 ADD PG 4.13.2 (NOW SHOP PRACTICE) (MER 150 EDD 2.9)	DEF 4-10-74	DLO 9/18/74 RF	A	BY REV: SER OUT C611501-0201; SER IN C611501-0203 ED&RR 10608 (SR6292)	RAINES 10/22/69	JWH, MDS HFW JWH RF
				B	BY REV: ADDED DETAIL B; S-2135-1 LIGHT ASSY; C593001-0101 OVERVOLTAGE SENSOR; WIRES PB7, PB8 & PB9. S-1943-2 TERM WAS S-1943-1 (SR6780&6781)IX	WDA 6-1-71	HFW HFW RF
				C	BY REV: REPLACED S-1370-1 TERM WITH S-1635-1 TERM ON PB7 & PB8 ADDED S-1637-1 HOUSING TO EQUIP TABLE. ADD TVA-1315 CAPACITOR TO F/D & E/T. SER 15073084 & ON	MIA VRS 1-4-72	HFW HFW RF
				D	BY REV: ADD WIRE LENGTHS; REWIRE S-2135-1 (PAGE A.13.1) S-1636-1 WAS S-1635-1/PB8 (NOW SHOP PRACTICE)	DLO 6-25-72	HFW HFW RF
				E	BY REV: SER OUT C611001-0101 SER IN C611001-0102; ADD DETAIL "C" & PB33 (SR7624)(SR7639)	RAM 7-31-73	HFW HFW RF
				F	BY REV: S-1635-2 WAS S-1635-1/PB7 & PB8; S-1636-2 WAS S-1636-1/PB8 & PB9; S-1367-2-10 WAS S-1367-4-10/FC1; S-1994-1 WAS S-1690- 1-1; S-1493-1 WAS S-1367-2-3/PB6; S-1493-1 WAS S-1367-1-3/PB3; ADD FC1 TO DETAIL "B" (NOW SHOP PRACTICE)	TDN DLO 12-13-73	HFW HFW RF

INACTIVE
EFF THRU SER(SR7900)(SR7901)(SR7902)
S-15-74
DLO
9/18/74
RF

00-223-0905

NOTES:

1. TERMINAL 42281-2(00779) ON CONDUCTOR.
TERMINAL 2-323931-2(00779) ON SHIELD & GND
WIRE.
2. WIRE MATERIAL PER S-1534-8-9.
3. OBSERVE POLARITY SYMBOL ON DIODE WHEN
INSTALLING ON SW TERM OR DIODE WILL FAIL
WHEN SYSTEM IS ENERGIZED.
4. "D" PREFIX IS USED BECAUSE THESE WIRES ARE
ALSO IN 0770750.

18	C611001-0102	REGULATOR	
17	TVA-1315	CAPACITOR	56289
16	S-1637-2	HOUSING-SOCKET	
15	S-1637-1	HOUSING-PIN	
14	S-2135-1	LIGHT ASSY	
13	C593001-0101	OVERVOLTAGE SENSOR	
12	C611501-203	ALTERNATOR ASSY	
11	S-1915-1	FILTER ASSY	
10	S-1596-60	CIRCUIT BREAKER	
9	CAB	CIRCUIT BREAKER (80602)	
8	S-1994-1-1	MASTER SWITCH	
7	0770719-2	DIODE ASSY	
6	S-1640-9	HOUSING-PIN	
5	S-1641-9	HOUSING-SOCKET	
4	0770038-2	FILTER	
3	C648-10A730-A	HOUSING (88690)	
2	C611001-0101	REGULATOR	
1	C611501-0201	ALTERNATOR ASSY	

PB33	B	S-1562-8-9	21	S-1943-3	S-1367-4-12			SER(SR7639)EDN-150757246 A1500500 & ON
PB9	18		100	S-1636-2	42281-2	(00779)		SER(SR6780&6781)& ON
PB8	16		32	S-1635-2	S-1636-2			SER(SR6780&6781)& ON
PB7	16		7	S-1367-2-8	S-1635-2			SER(SR6780&6781)& ON
PB6	16			S-1493-2	S-1367-2-8			THRU SER(SR6780&6781)
PB31	185		8	S-1493-1	S-1635-2			
D-PB29	18		8	S-1367-1-12				
D-PB28	185		23	S-1367-1-12				
D-PB27	185		10	S-1367-2-10				
D-PB26	185		23	S-1367-2-8				
PB11	10		21	S-1367-3-10	S-1367-3-12			THRU SR(7639)-150757246, A1500499
PB10	85		54	S-1367-3-10	S-1367-4-10			
PB32	185		50	S-1636-2	S-1367-3-8			
FC1	16		6	S-1367-2-10	S-1367-2-10			

WIRE TABLE			WIRE TABLE		
WIRE CODE NO.	GA	MATERIAL	LG	TERMINALS	SERIALS
CONTRACT NO:					
DESIGN HENSHAW 4-10-69			COMMERCIAL AIRCRAFT DIV. 5800 E. PAWNEE WICHITA, KANSAS		
GROUP H. Wier 4-9-69			Cessna AIRCRAFT CO.		
DRAWN F. RUNNER 4-9-69			TITLE		
CHECK J. HARRIS 4-8-69			WIRING DIAGRAM -		
STRESS Washington 4-9-69			ALTERNATOR SYSTEM, 60AMP		
PROJ J. H. Wier 4-11-69			SIZE		
APPD M. J. Wier 4-8-69			CODE IDENT. NO.		
OTHER			DWG NO.		
			C 71379		
			150		
			PAGE: 4,13.0		

EQUIPMENT TABLE	
PART NO.	DESCRIPTION
CES-1000	IS APPLICABLE
CES-XXXX	CESSNA SPEC. NO.
S-XXX	OR CMXXXX=CESSNA
STD. NO.	

SUPERSEDES:	
P 4.12	
SUPERSEDED BY:	
0470401	PAGE 4.2

ED&RR 10491 (SR 6040) IX
1507129

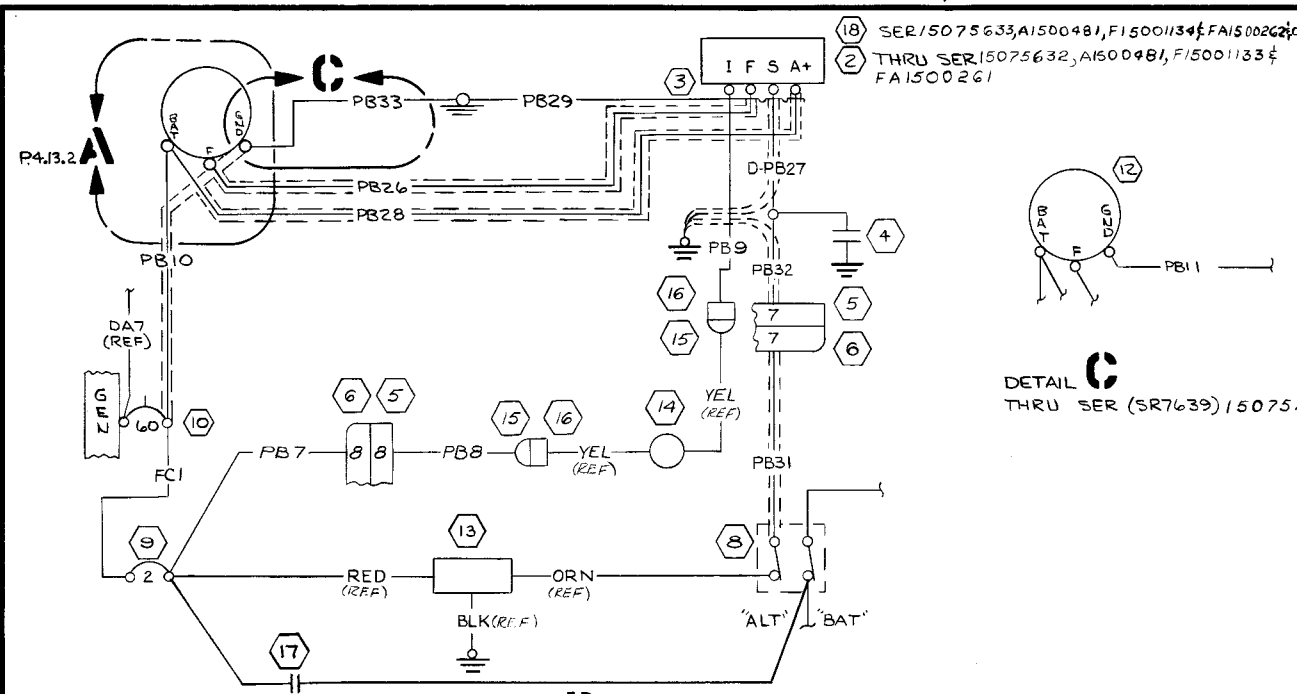

(18) SER 15075633, A1500481, F15001133 & FA1500261
 (2) THRU SER 15075632, A1500481, F15001133 & FA1500261

REVISION			
LET	DESCRIPTION	DATE	APPD
G	SEE PG 4.13.0 FOR REV		

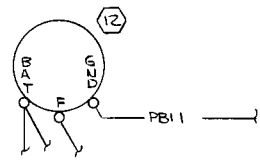

DETAIL C
 THRU SER (SR7639) 15075763 & A1500499

DETAIL 13
 SER (SR6780 & 6781) & ON
 SER 15072629, F15000739 &
 A1500277 & ON

INACTIVE SER (SR7900) (SR7901) (SR7902)
 EFF THRU BRP (15077000, A1500614)
 8-15-74
See SR99 inventory RF

500-223-0905

WIRE CODE NO.	GA	MATERIAL	LG	TERMINALS	SERIALS

WIRE TABLE			COMMERCIAL AIRCRAFT DIV.		
CONTRACT NO.			Cessna AIRCRAFT CO.		
DESIGN	NAME	DATE	TITLE		
GROUP	R. Winn	6-1-71	WIRING DIAGRAM — ALTERNATOR SYSTEM, 60 AMP		
DRAWN	ACKERSON	6-1-71			
CHECK	L.K. WHITE	5-27-71			
STRESS					
PROJ	R. Hammon	5-18-71			
APPD			SIZE	CODE IDENT. NO.	DWG NO.
OTHER			C	71379	0410011
			SCALE: NONE	150	PAGE: 4.13.1

ITEM NO.	PART NO.	DESCRIPTION
EQUIPMENT TABLE		
CES-1000 IS APPLICABLE		SUPERSEDES:
VENDOR CODES PER S-1400		SUPERSEDED BY:
CES-XXXX=CESSNA SPEC. NO.		0470401 PAGE 4.2
S-XXX OR CMXXXX=CESSNA STD. NO.		

Change 3 20-7

REVISION			
LET	DESCRIPTION	DATE	APPD
G	SEE PG. 4.13.0 FOR REV.		

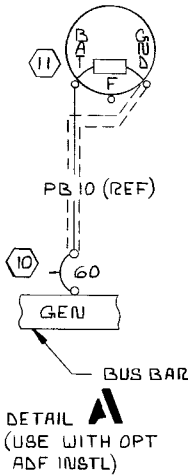
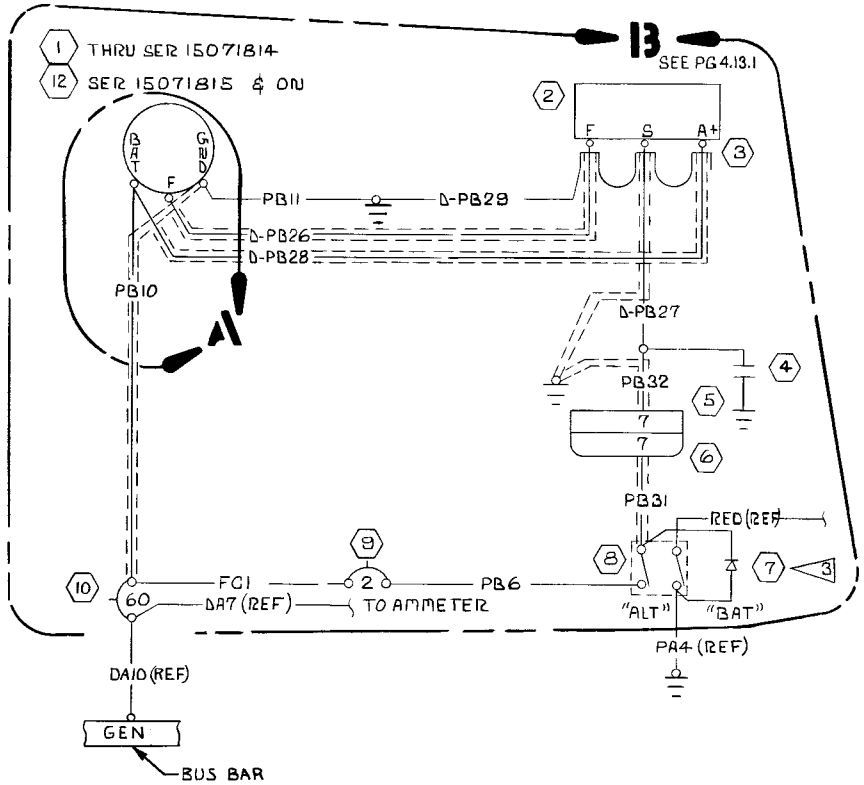

INACTIVE
EFF THRU SER (SR7900) (SR7901) (SR7902)
8-15-74
REF (15077000, A1500614)
D. J. FINCH
4-10-74
MIL
RF

00-223-0905

WIRE CODE NO.	GA	MATERIAL	LG	TERMINALS	SERIALS

WIRE TABLE		
CONTRACT NO:		COMMERCIAL AIRCRAFT DIV. 5800 E. FAWNEE WICHITA, KANSAS
DESIGN	NAME	DATE
GROUP	Cessna AIRCRAFT CO.	
DRAWN		TITLE
CHECK		WIRING DIAGRAM - ALTERNATOR SYSTEM, 60 AMP
STRESS		
PROJ	SIZE	CODE IDENT. NO.
APPD	C	71379
OTHER	DWG NO	0410011
SCALE: NONE		PAGE: 4.13.2

ITEM NO.	PART NO.	DESCRIPTION
EQUIPMENT TABLE		
CES-1000 IS APPLICABLE VENDOR CODES PER S-1400 CES-XXXX-CESSNA SPEC. NO. S-XXX OR CMXXXX-CESSNA STD. NO.		SUPERSEDES: SUPERSEDED BY: 0470401 PG 4.2



REVISION			
LET	DESCRIPTION	DATE	APPD
A	BY REV: ADD JUMPER & SER OUT, ADD JAI1 (REF) & SER (15074191, A15000371)	DLP 12-28-72	By New REF
B	BY REV: 5A WAS 10A / STROBE LT & 25A WAS 10A / LDG LT (REF) (SR7000) & (SR7001) (REF)	RAM 3-12-74	By APP REF

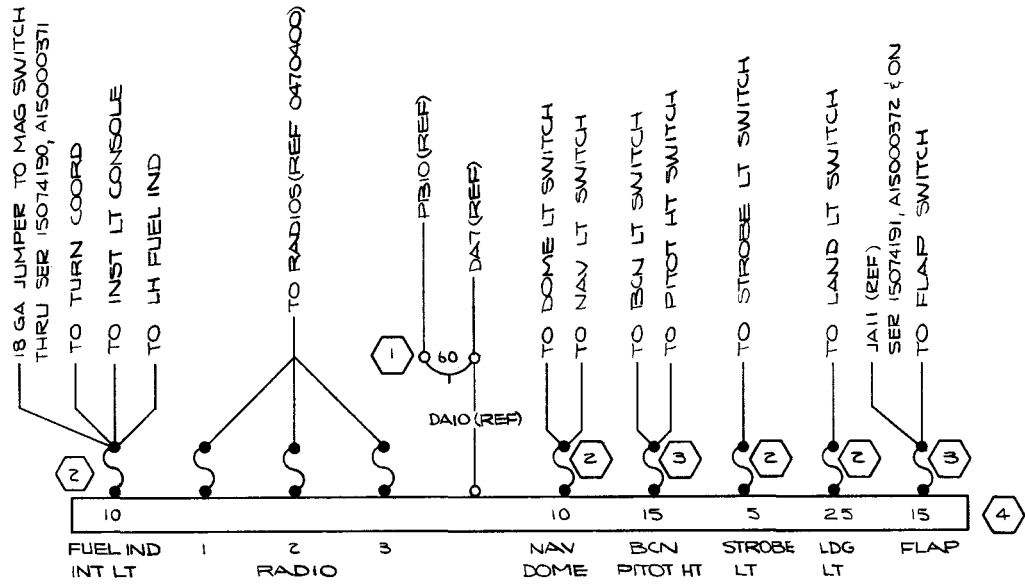

NOTES:

- THIS DWG IS FOR REF INFO ONLY. FOR WIRING & WIRE & TERMINAL REQUIREMENTS SEE APPROPRIATE PAGES OF 0410011

WIRE CODE NO.	GA	MATERIAL	LG	TERMINALS	SERIALS

WIRE TABLE

ITEM NO.	PART NO.	DESCRIPTION
4	0470007-1	BUS BAR
3	S-1091-15	FUSE
2	S-1091-10	FUSE
1	S-1596-60	CKT BKR

EQUIPMENT TABLE

ITEM NO.	DESCRIPTION
CES-1000	IS APPLICABLE VENDOR CODES PER S-1400 CES-XXXX-CESSNA SPEC. NO. S-XXX OR CMXXXX-CESSNA STD. NO.
SUPERSEDES:	P 4.5
SUPERSEDED BY:	

CONTRACT NO:			COMMERCIAL AIRCRAFT DIV. 5800 E. PAWNEE WICHITA, KANSAS		
DESIGN	NAME	DATE	WIRING DIAGRAM — BUS BAR, CIRCUIT BREAKER & FUSE		
GROUP	<i>H. Wild</i>	4-30-70			
DRAWN	<i>PAPE</i>	4-29-70			
CHECK	<i>L.K. WHITE</i>	4-30-70			
STRESS			SIZE	CODE IDENT. NO.	DWG NO.
PROJ	<i>R. Youngers</i>	4-30-70	C	71379	0410011
APPD	<i>R. Youngers</i>	4-30-70	SCALE: NONE	150, A150	PAGE: 4-14
OTHER			EDRR 10021 (SR6350)(SR6351)IX		

Change 2
20-8A/(20-8B blank)

This page intentionally left blank.

REVISION			
LET	DESCRIPTION	DATE	APPD
A	BY REV: ADD JUMPER & SER OUT; ADD J111 (REF) & SER (15074191, A1500037Z)	DLP 12-28-72	<i>[Signature]</i>
B	BY REV: 5A WAS 10A/STROBE LT & 25A WAS 10A/LDG LT (REF) (SR7000) & (SR7001) (REF)	RAM 3-12-74	<i>[Signature]</i>

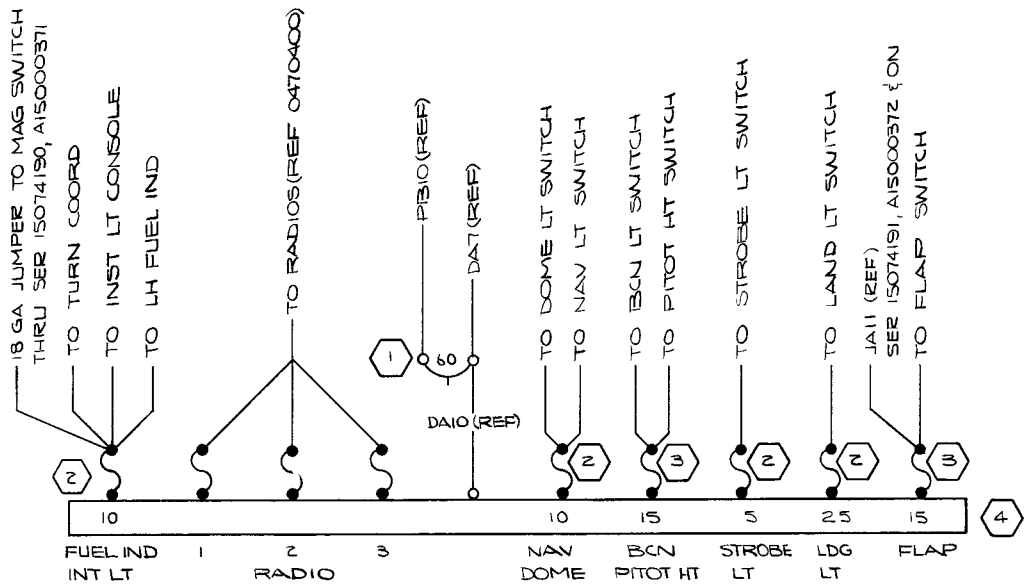

INACTIVE
EFF THRU SER (SR7900) (SR7901) (SR7902)
8-15-74
BRF (15077000, A1500614)
[Signature]

NOTES:

- THIS DWG IS FOR REF INFO ONLY. FOR WIRING & WIRE & TERMINAL REQUIREMENTS SEE APPROPRIATE PAGES OF 0410011

WIRE CODE NO.	GA	MATERIAL	LG	TERMINALS	SERIALS

PART NO.	DESCRIPTION	QUANTITY
4	0470007-1 BUS BAR	
3	5-1091-15 FUSE	
2	5-1091-10 FUSE	
1	5-1598-60 CKT BKR	

ITEM NO.	PART NO.	DESCRIPTION
EQUIPMENT TABLE		

CES-1000 IS APPLICABLE
VENDOR CODES PER S-1400
CES-XXXX=CESSNA SPEC. NO.
S-XXX OR CMXXXX=CESSNA
STD. NO.

SUPERSEDES:
P 4.3

SUPERSEDED BY:
0470401 4.3

CONTRACT NO:			COMMERCIAL AIRCRAFT DIV. 5800 E. PAWNEE WICHITA, KANSAS		
DESIGN	NAME	DATE	Cessna AIRCRAFT CO. TITLE: WIRING DIAGRAM - BUS BAR, CIRCUIT BREAKER & FUSE		
GROUP	<i>H. Wild</i>	4-30-70			
DRAWN	<i>PAPE</i>	4-29-70			
CHECK	<i>L.K. WHITE</i>	4-30-70			
STRESS					
PROJ	<i>D. Lyle</i>	4-30-70	SIZE	CODE IDENT.	DWG NO
APPD	<i>RNOYNGERS</i>	4-30-70	C	71379	0410011
OTHER			SCALE:	NONE	150, A150 PAGE: 4.14

EDPR 10021 (SR6350)(SR6351) X
(15072004, A1500227, F1500639, A1500081)

Change 3 20-9

00-223-0905

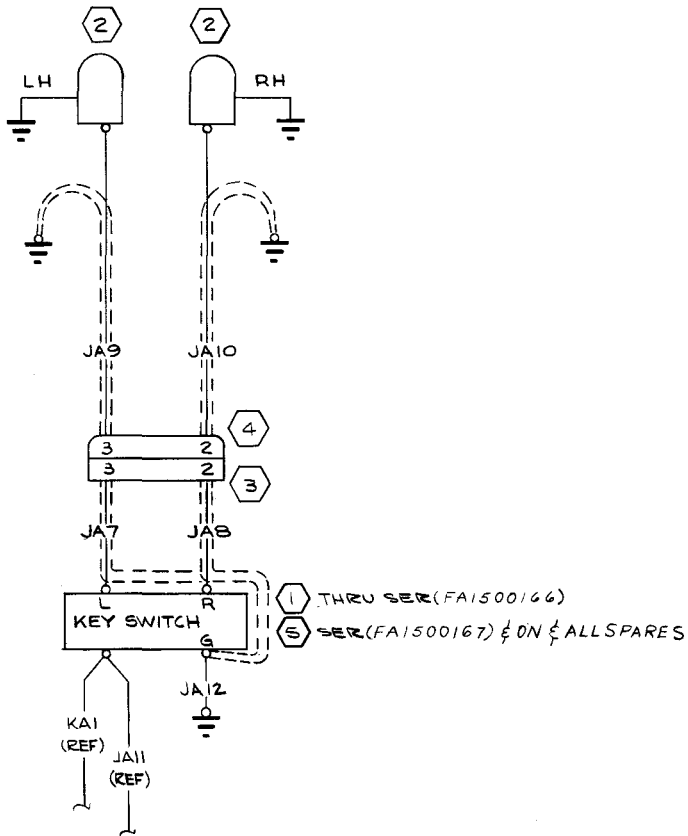

REVISION			
LET	DESCRIPTION	DATE	APPD
A	BY REV: ITEM 3 WAS ITEM 4 & ITEM 4 WAS ITEM 3 IN FIELD ED&RR 01990 (SR5437) IX	RLY 3-27-68	GKI MDS H/W D&K
B	BY REV: SER OUT C292501-0101; SER IN C292501-0105 (SR7126)	RLY 2-29-72	W/W H/W RF
C	BY REV: ADD KA1 (REF) & JA11 (REF)	DLP 12-28-72	W/W H/W RF
D	BY REV: ADD WIRE LENGTHS (NOW SHOP PRACTICE)	DLO 3-5-73	W/W H/W RF
E	BY REV: ADD JA12 WIRE; S-1636-1 PER JA9 & 10 WAS S-1635-1, S-1635-1 PER JA7 & 8 WAS S-1636-1. (NOW SHOP PRACTICE) (SR7300)(SR7301) (MER 150-0030)	BAH 8-7-79	JX H/W RF

INACTIVE
EFF THRU SER (SR7900) (SR7901) (SR7902)
B-15-74
BREF (15077000, A1500612)

5060-823-00

WIRE CODE NO.	GA	MATERIAL	LG	TERMINALS	SERIALS
JA12	18	12 S-1367-1-6	S-1367-1-B		(SR7300)(SR7301) & ON
JA10	185	65 S-1636-1	S-1367-1-10 S-1367-2-6		
JA9	185	60 S-1636-1	S-1367-1-10 S-1367-2-6		
JA8	185	8 S-1635-1	S-1367-1-10 S-1367-2-6		
JA7	185	8 S-1635-1	S-1367-1-10 S-1367-2-6		

ITEM NO.	PART NO.	DESCRIPTION	VENDOR
5	C292501-0105	IGNITION SWITCH	
4	S-1641-9	HOUSING-SOCKET	
3	S-1640-9	HOUSING-PIN	
2	447	MAGNETOS	(09033)
1	C292501-0101	MAG SWITCH	

EQUIPMENT TABLE	
PART NO.	DESCRIPTION
	KEY SWITCH

CES-1000 IS APPLICABLE VENDOR CODES PER S-1400 CES-XXXX-CESSNA SPEC. NO. S-XXX OR CMXXXX-CESSNA STD. NO.	SUPERSEDES: 0410011 P. 5.2
	SUPERSEDED BY: 0470401 P 5.1

CONTRACT NO:		Cessna AIRCRAFT CO.		COMMERCIAL AIRCRAFT DIV. 5800 E. PAWNEE WICHITA, KANSAS	
DESIGN	NAME	DATE	TITLE		
GROUP	H. Wind	12-18-67	WIRING DIAGRAM - MAGNETOS		
DRAWN	HARRIS	12-12-67			
CHECK	LAURIE	12-14-67			
STRESS	amp	12-16-67			
PROJECT	D.G. Koller	12-20-67	SIZE	CODE IDENT. NO.	DWG NO.
APPD	MARTEN	12-15-67	C	71379	0410011
SCALE: NONE			150	PAGE: 5/3	

SER 15064538 & ON

CHG LET	REVISION	BY DATE	CHK APPD
A	BY REV: ADD DETAIL A & SER, PA13, S-1640-9, S-1641-9, RED & S-1159-1; SER OUT PA12, EDERR 00948 (SR 5437) II	JWH 12/12/67	RLY RLY RLY RLY
B	BY REV: ITEM 9 WAS ITEM 10 & ITEM 10 WAS ITEM 9 IN FIELD; S-1635-1/RED WIRE WAS S-1635-1/PA13 & S-1636-1/PA13 WAS S-1636-1/RED WIRE; ADD DETAIL B & SER; SER OUT PA10 EDERR 0990 & 02332 (SR 5437) II	RLY 4-8-68	GKI MDS RLY RLY RLY
C	BY REV: ADD DETAIL "C" & S-1690-1-1. EDERR 10491 (SR 6040)-II	FER 4-4-68	JWH MDS RLY RLY
D	BY REV: ADD DETAIL "D", DA10(REF); SER EDERR 10021 (SR 6350) (SR 6351) II	DLP 4-29-70	DLP JWH RLY RF
E	BY REV: SER OUT S-1579-1 & ADD S-1579-2 (SR 7201)	BPH 6-14-72	BPH JWH RLY RF
F	BY REV: ADD WIRE LENGTHS (NOW SHOP PRACTICE)	JLD 5-4-73	JLD JWH RF
G	BY REV: SER OUT S-1690-1-1, RED & PA4: SER IN S-1994-1-1, PA15 & PA16 SER 15073961	JLD 12-13-73	JLD JWH RF
H	BY REV: PA14(REF) WAS PA10 (NOW SHOP PRACTICE) (SER 150E0029)	JEK 4-10-74	JEK JWH RF

INACTIVE
EFF THRU SER(SR7201)(SR7202)
S-1579-2
(S-1579-1)
S-1506619
RF
CO-223-0905

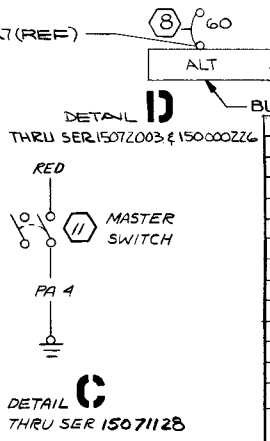
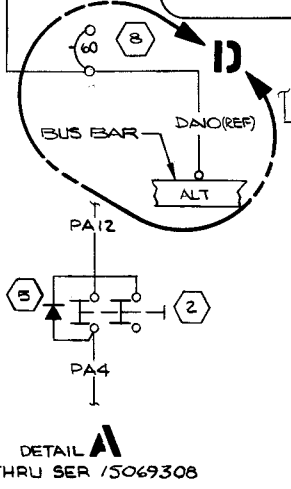
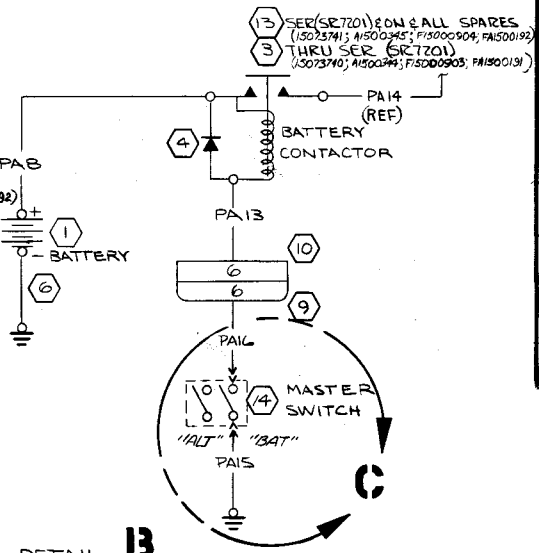
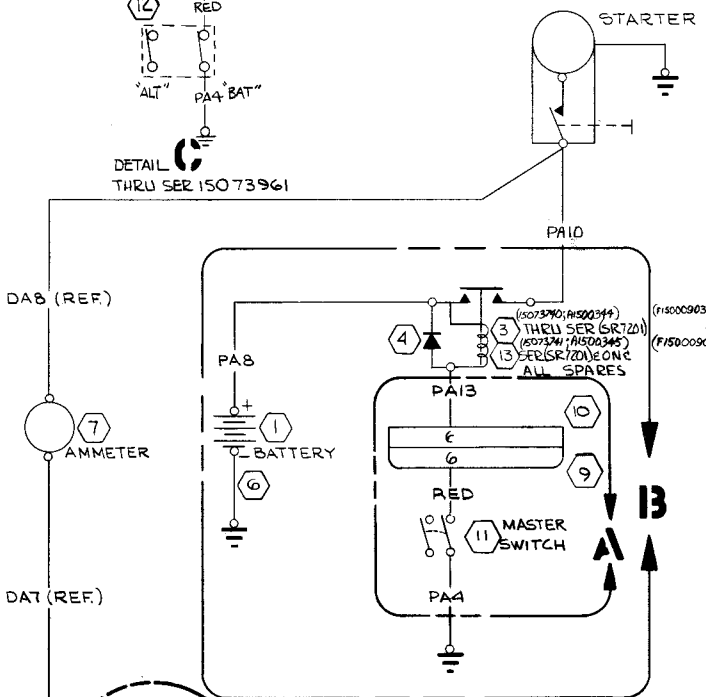
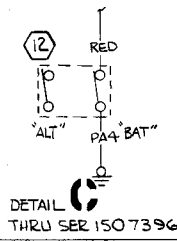

ITEM NO	PART NO.	DESCRIPTION	INSTALLED ON
14	S-1994-1	SWITCH-MASTER	
13	S-1579-2	CONTACTOR	
12	S-1690-1-1	SWITCH-MASTER	
11	S-1159-1	SWITCH-MASTER	
10	S-1641-9	HOUSING-SOCKET	
9	S-1640-9	HOUSING-PIN	
8	S-1596-60	CIRCUIT BREAKER	
7	S-1320-1	AMMETER	
6	0412007-9	STRAP-BAT GND.	
5	0770719-1	DIODE ASSY.	
4	0770728-1	DIODE ASSY.	
3	S-1579-1	CONTACTOR	
2	0713026-5	SWITCH-MASTER	
1	0511319-1	BATTERY, 12V	

WIRE CODE NO.	GA	MATERIAL	LG	TERMINALS	SERIALS
PA16	18	B	S-1635-1	S-1493-1	SER(SR 7232) & ON
PA15	18	3	S-1493-1	S-1367-8	SER(SR 7232) & ON
RED	18	-18-2	S-1635-1	S-1493-18	THRU SER(SR 7232)
PA13	18		S-1367-1-10	S-1636-1	
PA12	18		S-1367-1-10	S-1367-1-8	THRU SER 15069308 & 15073961
PA10	4		S-1367-6-13	S-1367-6-14	THRU SER 15069308 & 15073961
PA8	4		S-1367-6-14	S-1367-6-13	THRU SER(SR 7232)
PA4	18		S-1367-8	S-1367-8	

CESSNA AIRCRAFT CO., COMMERCIAL AIRCRAFT DIVISION, WICHITA, KANSAS

WIRE TABLE

DRAWN	NAME	DATE	TITLE
GROUP	Bliss	10-8-65	WIRING DIAGRAM - CONTACTOR & STARTER
CHECK	H. Wino	10-30-65	
PROJ	Ed Stock	11-2-65	

FORM NO. 0410011

REV: F PAGE: 6.3

REVISION			
LET	DESCRIPTION	DATE	APPD
A	BY REV: ADD DETAIL A, S-1991-1 & SR. ED & RR 10474 (SR6222)	MDS 5-23-69	RLY RF MOS LW YFW
B	BY REV: SER OUT S-1579-1 & ADD S-1579-2 (SR7201)	BPH 6-16-72	LW RF MOS YFW
C	BY REV: ADD S-1091-15, J111 & SER (SER 15074191, A1500037Z)	DLP 12-28-72	RLY RF MOS YFW
D	BY REV: C292501-0101 "B" WAS "S", ADD WIRE LENGTHS, S1367-7-13 WAS S1367-6-13 & 2GA WAS 4GA, ADD S1367-7-13 PER KA3 (NOW SHOP PRACTICE)	JLO 3-16-73	RLY RF MOS YFW
E	BY REV: ADD S TERMINAL TO C292501-0101 SWITCH (NOW SHOP PRACTICE)	JLO 6-25-73	RLY RF MOS YFW

INACTIVE
EFF THRU SER (SR7900) (SR7901) (SR7902)
8-15-74
BRF (15077000, A1500614)
JFW
MOS
YFW

5060-632-00

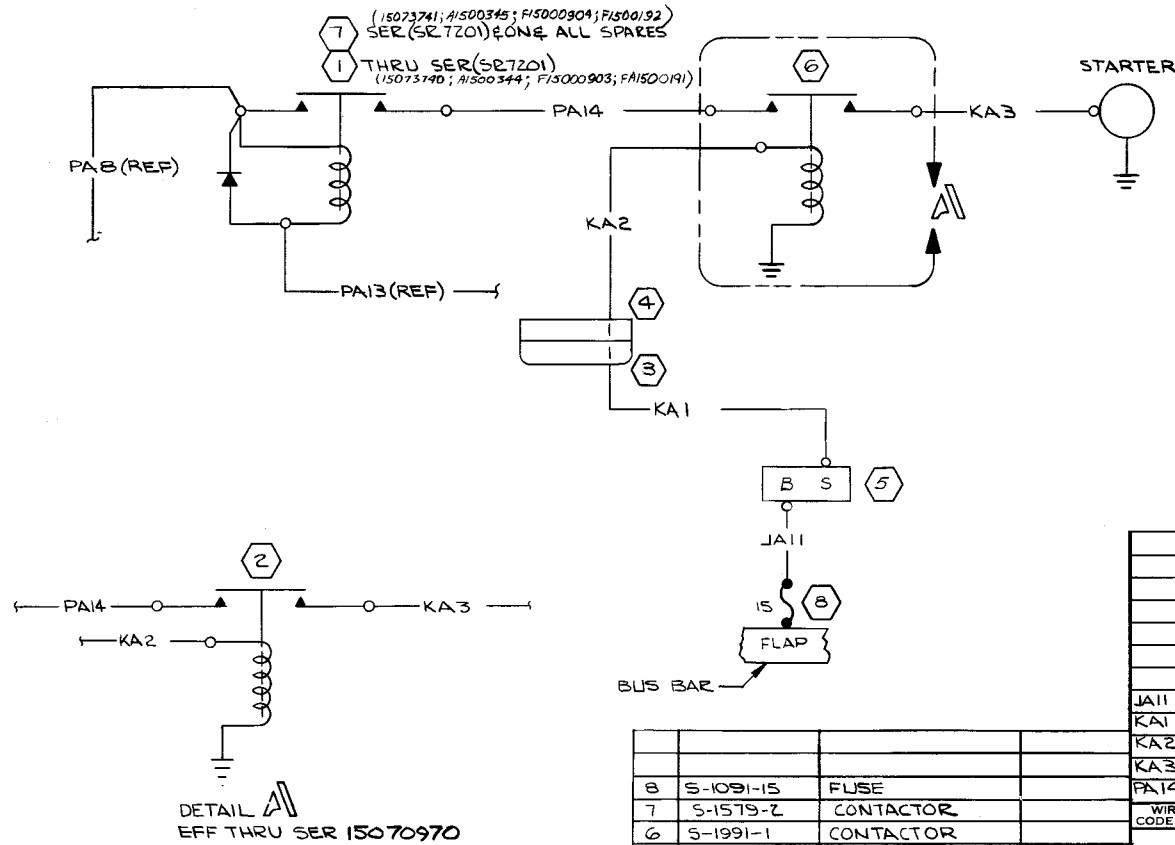

ITEM NO.	PART NO.	DESCRIPTION
8	S-1091-15	FUSE
7	S-1579-2	CONTACTOR
6	S-1991-1	CONTACTOR
5	C292501-0101	IGNITION SWITCH
4	S-1641-9	HOUSING (SOCKET)
3	S-1640-9	HOUSING (PIN)
2	S-1660-1	CONTACTOR
1	S-1579-1	CONTACTOR

EQUIPMENT TABLE	
ITEM NO.	DESCRIPTION
8	S-1367-1-10
KA1	B
KA2	B
KA3	55
PA14	18

WIRE CODE NO.	GA	MATERIAL	LG	TERMINALS	SERIALS
J111	18				
KA1	18				
KA2	18				
KA3	2				
PA14	4				

CONTRACT NO:			WIRE TABLE		
DESIGN	COOL	4-15-68	NAME	DATE	
GROUP	H. W. W.	4-11-68	DESIGN	COOL	4-15-68
DRAWN	YOUNGERS	4-8-68	GROUP	H. W. W.	4-11-68
CHECK	G. IRVIN	4-9-68	DRAWN	YOUNGERS	4-8-68
STRESS	R. W.	4-11-68	CHECK	G. IRVIN	4-9-68
PROJECT	D. K. Kella	4-15-68	STRESS	R. W.	4-11-68
APPD	SWANEY	4-10-68	PROJECT	D. K. Kella	4-15-68
SIZE	C		APPD	SWANEY	4-10-68
CODE IDENT. NO.	71379		SIZE	C	
DWG. NO.	0410011		CODE IDENT. NO.	71379	
SCALE: NONE	150		DWG. NO.	0410011	
PAGE: 6.4			SCALE: NONE	150	

ED & RR 02332 (SR5437) IX
(15062309; F15000390)

CHG DATE	REVISION	BY DATE	CHK APPD	CHG LET	REVISION	BY DATE	CHK APPD	
E	BY REV: S-1640-9 & S-1641-9 WERE S-1640-6 & S-1641-6/RH WING, S-1636-1 WAS S-1636-2/EB8 & EB9, S-1635-1 WAS S-1635-2/YELLOW; S-1636-1 WAS S-1635-1 PER EB10 S-1635-1 WAS S-1636-1 PER EB10 (NOW SHOP PRACTICE) MER ISO E0020	BAH 10-74	JLO		A	BY REV: DELETED ITEM 3 FROM OPT. PATROLER WING DETAIL & ADDED ITEM 2; LEFT & RIGHT FUEL TANK GAGE WAS IN; IN EIT XMTR-FUEL LEVEL WAS GAGE (2); 0413035-1 WAS C069504-0202	JRH 7-20-66	JRH
			DEF		B	BY REV: ADD S-1640-6; S-1641-6, EB10, EB11 & DETAIL A & SER; SER OUT EB6. ED & RR 00948 (SR5437) II	JWH 12-6-67	RLC
					C	BY REV: ITEM 9 WAS ITEM 8 & ITEM 8 WAS ITEM 9 IN FIELD ED & RR 01990 (SR5437) II	RLY 3-27-68	RLC
					D	BY REV: ADD WIRE LENGTHS (NOW SHOP PRACTICE)	JLO 5-4-75	JLO

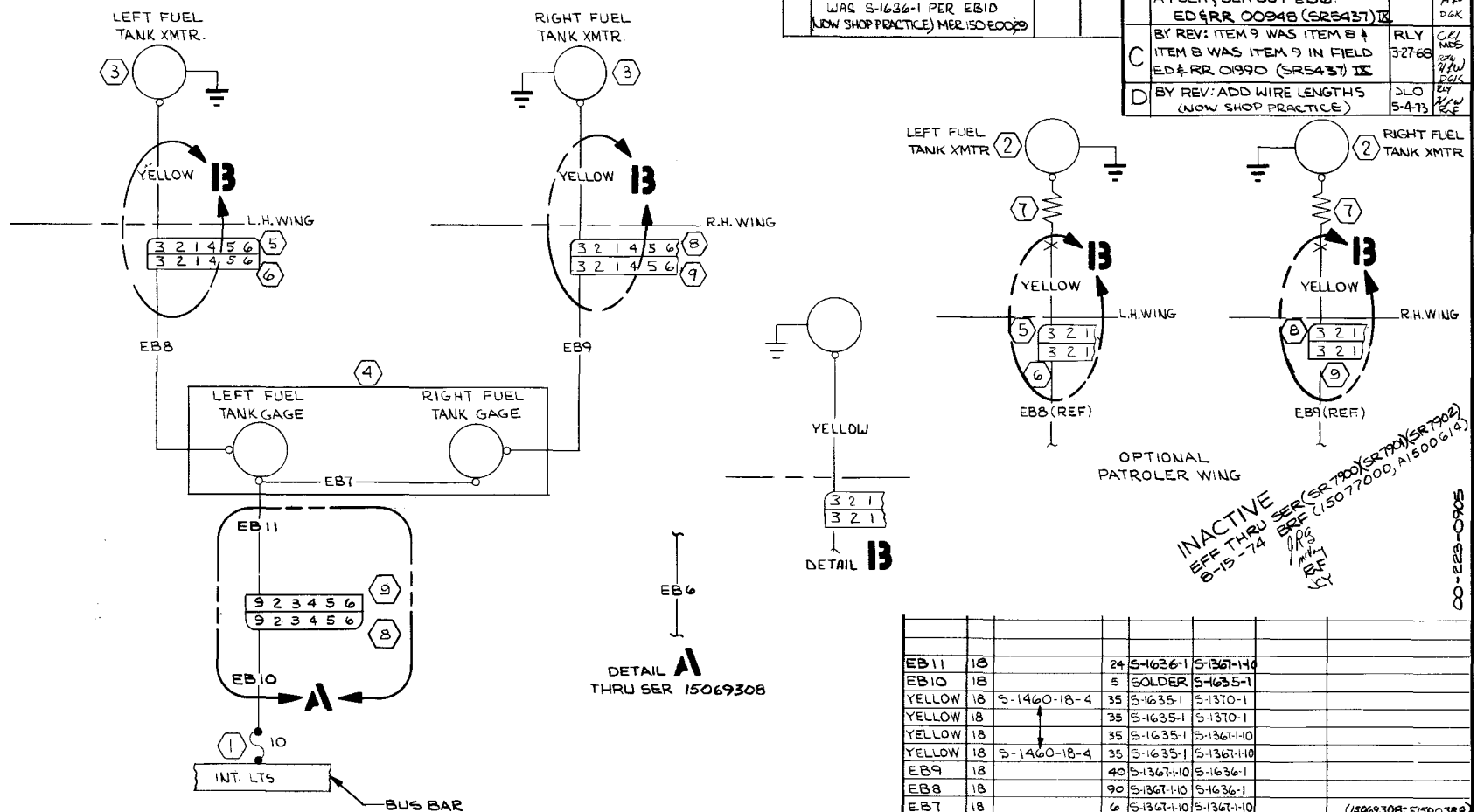

INACTIVE
EFF THRU
8-15-74
SER (SR 7900) (SR 7901) (SR 7902)
REF (15077200, A1500612)
DAS UNIT REF
CO-EB8-0905

QTY	PART NO.	DESCRIPTION	INSTALLED ON
9	S-1641-9	HOUSING-SOCKET	
8	S-1640-9	HOUSING-PIN	
7	20 Ω 5W	RESISTOR (OM)	
6	S-1641-6	HOUSING-SOCKET	
5	S-1640-6	HOUSING-PIN	
4	0413035-1	PANEL ASSY.	
3	0426517-1	XMTR.-FUEL LEVEL	
2	0426517-2	XMTR.-FUEL LEVEL	
1	S-1091-10	FUSE	

WIRE CODE NO.	GA	MATERIAL	LG	TERMINALS	SERIALS
EB11	18		24	S-1636-1	S-1367-140
EB10	18		5	SOLDER	S-1635-1
YELLOW	18	S-1460-18-4	35	S-1635-1	S-1370-1
YELLOW	18		35	S-1635-1	S-1370-1
YELLOW	18		35	S-1635-1	S-1367-110
YELLOW	18	S-1460-18-4	35	S-1635-1	S-1367-110
EB9	18		40	S-1367-110	S-1636-1
EB8	18		90	S-1367-110	S-1636-1
EB7	18		6	S-1367-110	S-1367-110
EB6	18			SOLDER	S-1367-110 (15064533) THRU SER (SR5437)

WIRE TABLE			
CESSNA AIRCRAFT CO., COMMERCIAL AIRCRAFT DIVISION, WICHITA, KANSAS			
DRAWN	NAME	DATE	TITLE
	BLISS	10-8-65	WIRING DIAGRAM—
GROUP	R. W. W.	10-29-65	FUEL IND. & XMTR
CHECK	R. W. W.	10-30-65	
PROJ	R. W. W.	11-2-65	
SUPERSEDED BY:		SUPERSEDES:	
0410401 PB.1		0410011 PG.8.1.1	
MODEL: 150		PAGE: 8.1.2	

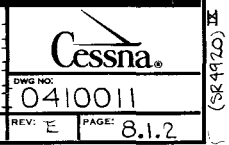

(SR 5033)

CHG LET	REVISION	BY DATE	CHK APPD
A	BY REV: SER SR7201 & ADD S-1579-2 (SR7201)	BPH 6-16-72	WJW RF
B	BY REV: ADD WIRE LENGTHS, SER OUT DF1; ADD DETAIL "A" UOW SHOP PRACTICE (SR7301)	JLO 3-13-73	WJW RF
C	BY REV: DC4(REF) WAS DC2(REF); DC7(REF) WAS DC3(REF); ADD S-1637-1 & S-1637-2 (NOW SHOP PRACTICE) MERIS0E0029	JEF 4-10-74	JLO WJW RF

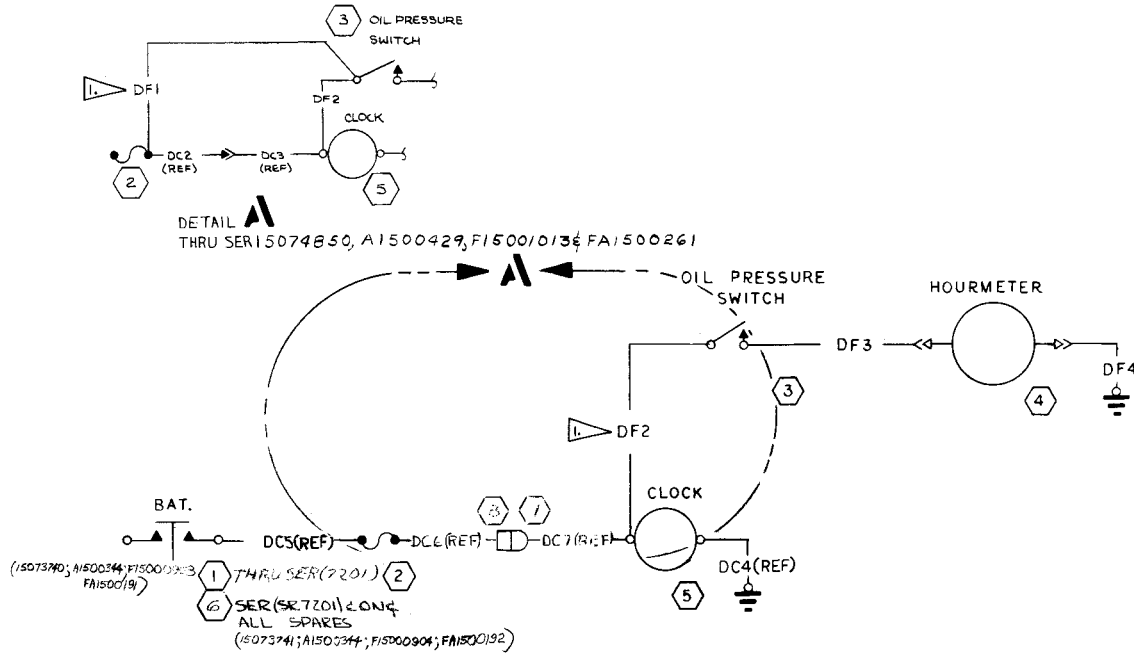

INACTIVE
EFF THRU SER(SR7000)(SR7201)(SR7302)
8-15-74
RF (15077000, A1500619)
WJW
RF

NOTE:
WIRING DIAGRAM SHOWN IS FOR USE WHEN AN OPTIONAL ELECTRIC CLOCK IS INSTALLED. WHEN ELECTRIC CLOCK IS NOT INSTALLED WIRE A/D/FY DF2 CONNECTS PRESSURE SWITCH TO FUSEHOLDER. INSTALL S-1091-1 FUSE AND S-1690-22 FUSEHOLDER.

WIRE CODE NO.	GA	MATERIAL	LG	TERMINALS	SERIALS
DF4	18		5	S-1493-1 S-1367-18	
DF3	18		96	S-1493-1 S-1367-16	
DF2	18		51	S-1367-16 S-1367-16	
DF1	18		50	S-1367-16 SOLDER	THRU SER A1500429

PART NO.	DESCRIPTION	INSTALLED ON
8	S-1637-2 HOUSING	
7	S-1637-1 HOUSING	
6	S-1579-2 CONTACTOR	
5	S-1317N1 CLOCK	
4	C66450F0101 HOURMETER	
3	S-1711-1 OIL PRESSURE SW.	
2	S-1091-1 FUSE	
1	S-1579-1 BAT. CONTACTOR	

WIRE TABLE			
CESSNA AIRCRAFT CO. COMMERCIAL AIRCRAFT DIVISION WICHITA KANSAS			
DRAWN	NAME	DATE	TITLE
WJW	WJW	9-23-66	WIRING DIAGRAM - HOURMETER (OPT)
GROUP	H. Wied	9-27-66	
CHECK	R. Koch	9-28-66	
PROJ	Blatten	4-24-64	
SUPERSEDED BY: 0410011 B.2.1		REV: 0410401 P.8.2	MODEL: 150
EQUIPMENT TABLE		REV: C	PAGE: 8.2

5000-622-00

NOTES:

1. FE1, FE2, FE3, & FE4 ARE IDENTICAL TO & SUPERSEDE 0413384 - FE1, -FE2, -FE3, & -FE4 RESPECTIVELY

CHG LET	REVISION	BY	CHK
		DATE	APPD
A	CHANGED WIRE NOS IN B/M TO AGREE WITH FIELD	GR 7-3-63	RES AR 11/5 [Signature]

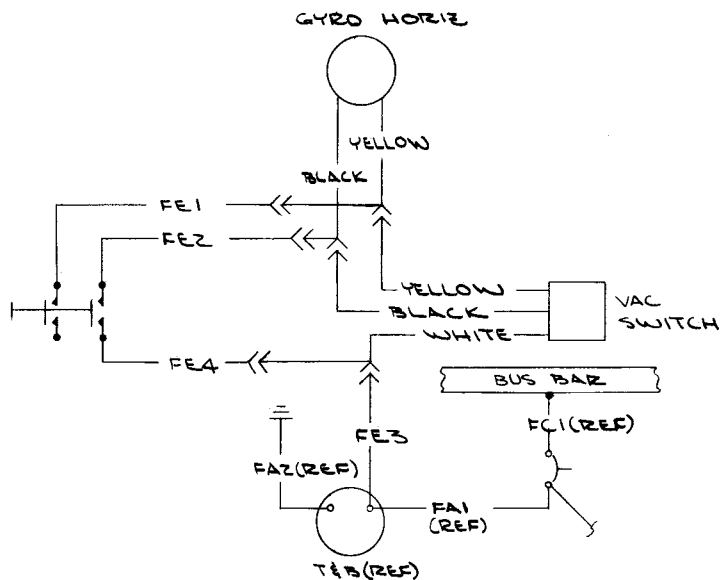

WIRE CODE NO.	GA	MATERIAL	LG	TERMINALS	SERIALS
FE4	20			S-341-2	
FE3	20			S-341-2	S15471-B
FE2	20			S-341-2	
FE1	20			S-341-2	

WIRE TABLE

CESSNA AIRCRAFT CO COMMERCIAL AIRCRAFT DIVISION WICHITA KANSAS

NAME	DATE	TITLE	
DRAWN JOHNSON	5-13-63	WIRING DIAGRAM	
GROUP PARSONS	5-22-63	PICTORIAL GYRO	
CHECK R.E. MOORE	5-17-63	(OPT)	
PROJ. [Signature]	5-22-63		
SUPERSEDED BY: NOTE 1			MODEL: 150
DWG NO: 0410011			REV: A PAGE: 3/3

(ITEM NO)	PART NO.	DESCRIPTION	INSTALLED ON
EQUIPMENT TABLE			

This page intentionally left blank.

REVISION			
LET	DESCRIPTION	DATE	APPD
A	BY REV: ADD WIRE LENGTHS (NOW SHOP PRACTICE)	JLO 3-15-73	RLV JLF RF
B	BY REV: ADD (STD) TO FA6; \$-1640-9 WAS \$-1640-6, \$-1641-9 WAS \$-1640-6; ADD FAB(REF)(NOW SHOP PRACTICE)(MERISDE002)	JEF 4-10-74	JLO V RF

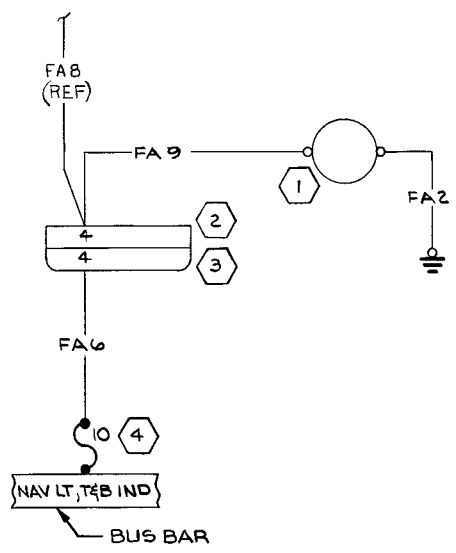

INACTIVE
EFF THRU SER(SR7900)(SR7901)(SR7902)
8-15-74
BREF(15077000, A1500619)
JLF
RF

00-228-0900

WIRE CODE NO.	GA	MATERIAL	LG	TERMINALS	SERIALS
FA9	18	16	S-1636-1	S-1321-18	
FA6	18	5	SOLDER	S-1635-1 (STD)	
FA2	18	10	S-1321-18	S-1321-18	

ITEM NO.	PART NO.	DESCRIPTION
4	S-1091-10	FUSE
3	S-1640-9	HOUSING-PIN
2	S-1641-9	HOUSING-SOCKET
1	S-1302N1	T&B INDICATOR

EQUIPMENT TABLE

CES-1000 IS APPLICABLE VENDOR CODES PER S-1400 CES-XXX=CESSNA SPEC. NO. S-XXX OR CMXXX=CESSNA STD. NO.

SUPERSEDES: 0410011 P.9.2

SUPERSEDED BY: 0470401 P.9.1

CONTRACT NO:			COMMERCIAL AIRCRAFT DIV. 5800 E. PAWNEE WICHITA, KANSAS	
DESIGN	NAME	DATE	TITLE	
W COOK		12-18-67	WIRING DIAGRAM -	
H. WIS		12-18-67	TURN & BANK	
HARRIS		12-12-67		
LAURIE		2-14-67		
STRESS	ans	12-16-67		
PROJECT	D.C. Keller	12-20-61	SIZE	CODE IDENT. NO.
APPD	MARTEN	12-15-67	C	71379
			DWG. NO.	0410011
			SCALE: NONE	150
			PAGE: 9.2.1	

ED&RR 00948 (SR 5437) IX (15063509; F1500390)

Change 3 20-15

NOTES:

1. FE1, FE2, FE3, & FE4 ARE IDENTICAL TO & SUPERSEDE 0413384-FE1, -FE2, -FE3, & -FE4 RESPECTIVELY

CHG LET	REVISION	BY	CHK
		DATE	APPD
A	CHANGED WIRE NOS IN B/M TO AGREE WITH FIELD	RD 7-3-63	RFJ 7-5-63

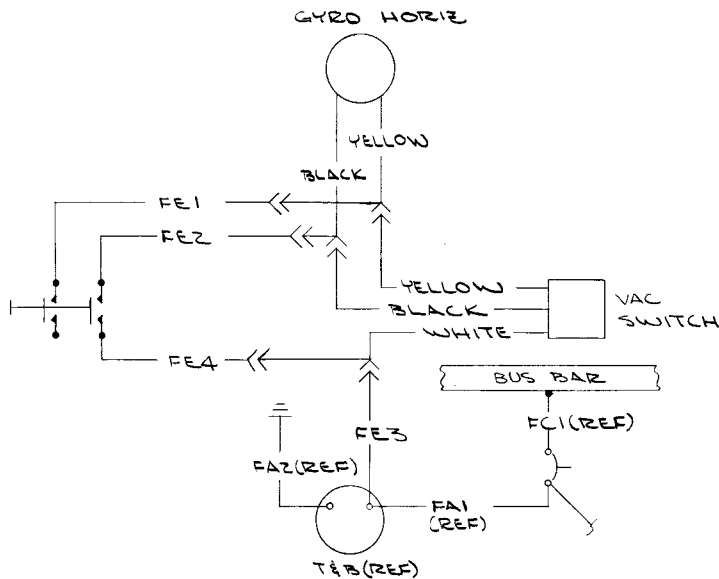

INACTIVE
EFF THRU SER 15060772
8-15-74
BRF
RFJ

5060-322-00

WIRE CODE NO.	GA	MATERIAL	LG	TERMINALS	SERIALS
FE4	20			S-341-2	
FE3	20			S-341-2	S13671-8
FE2	20			S-341-2	
FE1	20			S341-2	

WIRE TABLE

CESSNA AIRCRAFT CO., COMMERCIAL AIRCRAFT DIVISION, WICHITA, KANSAS

NAME	DATE	TITLE	
DRAWN JOHNSON	5-13-63	WIRING DIAGRAM -	
GROUP PARSONS	5-22-63	PICTORIAL GYRO	
CHECK R.E. Moore	5-17-63		
PROJ R. Miller	5-22-63		
SUPERSEDED BY NONE			
SUPERSEDED NOTE 1			
MODEL: 150			
REV: A			
PAGE: 3			
OWG NO: 0410011			

ITEM NO	PART NO.	DESCRIPTION	INSTALLED ON
EQUIPMENT TABLE			

REVISION			
LET	DESCRIPTION	DATE	APPD
A	BY REV: ADD NOTE NO. 4 (SR 7692)	M.E.M. 3-5-74	DLO RF

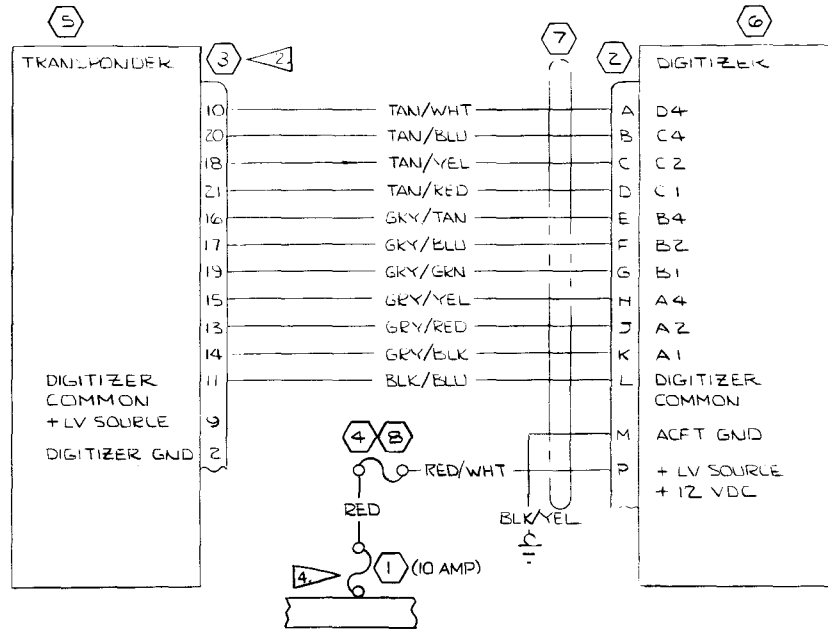

NOTES:

- 1. PINS ARE CRIMP TYPE AND FURNISHED BY VENDOR WITH CONNECTOR.
- 2. TRANSPONDER CONNECTOR HOUSING IS PART OF TRANSPONDER CABLE ASSY.
- 3. FOR WIRING DIAGRAM OF 300 TRANSPONDER REFER TO 3920143.
- 4. ATTACH BOTH TRANSPONDER AND ENCODING ALTIMETER TO THE NO. 3 FUSE.

ITEM NO.	PART NO.	DESCRIPTION
8	155104	FUSE HOLDER
7	1370212-2	CABLE ASSEMBLY
6	EA-401A	ALT DIGITIZER
5	RT-355A	TRANSPONDER
4	SFE 4	FUSE
3	S-2189-1	CONNECTOR
2	42816	CONNECTOR
1	S-1091-10	FUSE

EQUIPMENT TABLE	
CES-1000 IS APPLICABLE VENDOR CODES PER S-1400 CES-XXXX*CESSNA SPEC. NO. S-XXX OR CMXXXX*CESSNA STD. NO.	SUPERSEDES: SUPERSEDED BY:

WIRE CODE NO.	GA	MATERIAL	LG	TERMINALS	SERIALS
BLK/YEL	22	-22-0-4		S-13674-B	
TAN/WHT		-22-10-9		S-2190-1	
TAN/BLU		-22-10-6			
TAN/YEL		-22-10-4			
TAN/RED		-22-10-2			
GRY/TAN		-22-8-10			
GRY/BLU		-22-8-6			
GRY/GRN		-22-8-5			
GRY/YEL		-22-8-4			
GRY/RED		-22-8-2			
GRY/BLK		-22-8-0			
BLK/BLU	22	-22-0-6		S-2190-1	
RED/WHT	20	-20-2-9		SOLDER	
RED	18	-18-2		SOLDER	

WIRE TABLE		
CONTRACT NO:	NAME	DATE
DESIGN		
GROUP	<i>W. H. ...</i>	11-12-73
DRAWN	<i>J. COLLIER</i>	11-9-73
CHECK	<i>J. YOUEL</i>	11-9-73
STRESS		
PROJ	<i>J. D. ...</i>	11-19-73
APPD		
OTHER		
SIZE	CODE IDENT. NO.	DWG NO.
C	71379	0410011
SCALE: NONE	(SR 7692)	PAGE: 9.6

COMMERCIAL AIRCRAFT DIV.
5800 E. PAWNEE
WICHITA, KANSAS

Cessna AIRCRAFT CO.
TITLE
**WIRING DIAGRAM —
ENCODING ALTIMETER**

Change 2 20-16A/(20-16B blank)

This page intentionally left blank.

REVISIONS			
LTR	DESCRIPTION	DATE	APPROVED
A	BY REV: ADD S-1640-6, S-1641-6, FAT7, FAB & DETAIL A & SER; SER OUT FA4 ED & RR 00948 (SR 5437) II	JWH 12-6-67	RLC MWS D&K
B	BY REV: ADDED DETAIL B, ITEM 6 & FA6 (REF); OBSOLETE FAT (NEVER USED). ED4RR02376 (SR585T)	LES 6-12-68	GLI MDS MWS D&K
C	BY REV: S-1636-1 WAS S-1635-1/ FAB; S-1641-9 WAS S-1641-6; S-1640-9 WAS S-1640-6; ADD FA9 REF (NOW SHOP PRACTICE) (MER 150E0029)	TDN 4-10-79	MWS MWS MWS RF

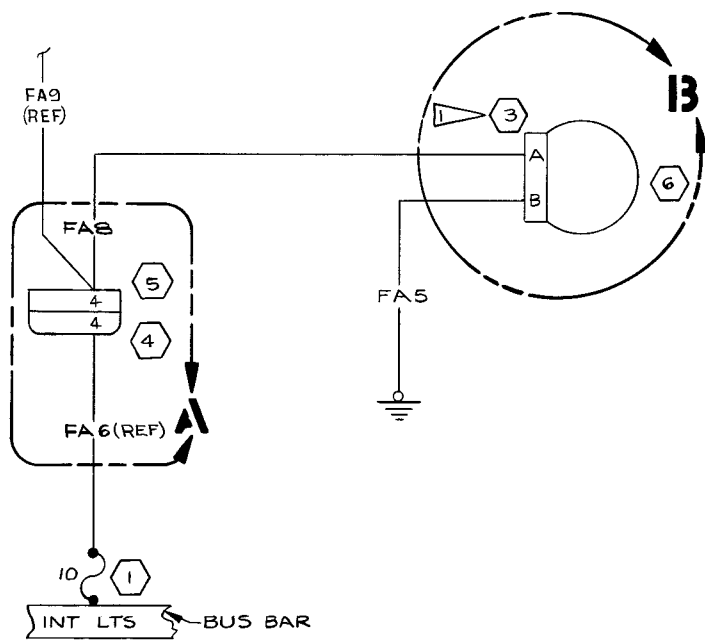

DETAIL A
THRU SER 15069309

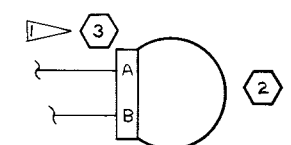

DETAIL B
EFF THRU SER 15070324

INACTIVE
EFF THRU SER (SR7900)
(SR7901)(SR7902) (15077000;
8-15-74
D&K
MWS
MWS
RF

00-223-0905

NOTES:
 M53106A10SL3S CONNECTOR IS SUPPLIED BY VENDOR

ITEM NO.	PART NO.	DESCRIPTION
6	C661003-0501	TURN COORDINATOR
5	S-1641-9	HOUSING-SOCKET
4	S-1640-9	HOUSING-PIN
3	M53106A10SL3S	CONNECTOR
2	C661003-0201	TURN COORDINATOR
1	S-1091-10	FUSE

WIRE CODE NO.	GA	MATERIAL	LG	TERMINALS	SERIALS
FA 8	18		26	SOLDER S-1636-1	
FA 7	18		12	SOLDER S-1635-1 OBSOLETE (NEVER USED)	
FA 5	18		10	SOLDER S-1367-1-B	
FA 4	18		38	SOLDER SOLDER (15067199) THRU SER 15069309	

CONTRACT NO: _____

DESIGN: W COOK DATE: 4-19-67
 GROUP: N. Y. W. DATE: 4-20-67
 DRAWN: VANDERHOOF DATE: 3/17/67
 CHECK: YAKSHAW DATE: 4-14-67
 STRESS: WOODINGTON DATE: 4-18-67
 PROJECT: M. J. Dutton DATE: 4-21-67
 APPD: ZG DATE: 4-14-67
 SAVER: SEDEF BY

WIRE TABLE

Cessna AIRCRAFT CO. COMMERCIAL AIRCRAFT DIV. 5800 E. PAWNEE WICHITA, KANSAS

TITLE: WIRING DIAGRAM - TURN COORDINATOR

SIZE: C CODE IDENT. NO.: 71379 DWG NO.: 0410011

0470401 P 9.2 SCALE: NONE (SR 5145) X PAGE: 9.4

Change 3 20-17

NOTES:

- ALL WIRING SHOWN FURNISHED WITH C661003-0401.

REVISIONS			
LTR	DESCRIPTION	DATE	APPROVED
A	BY REV: ADD S-1636-2, S-1640-6, S-1641-6, FAB & DETAIL A & SER. ED & RR 00948 (SR5437) IX	JWH 12-6-67	RLJ 1/2/68 DUC
B	BY REV: FAIO WAS FAB ED & RR 01990 (SR5437) IX	RLY 3-27-68	CKJ 1/20/68 D6K

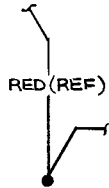
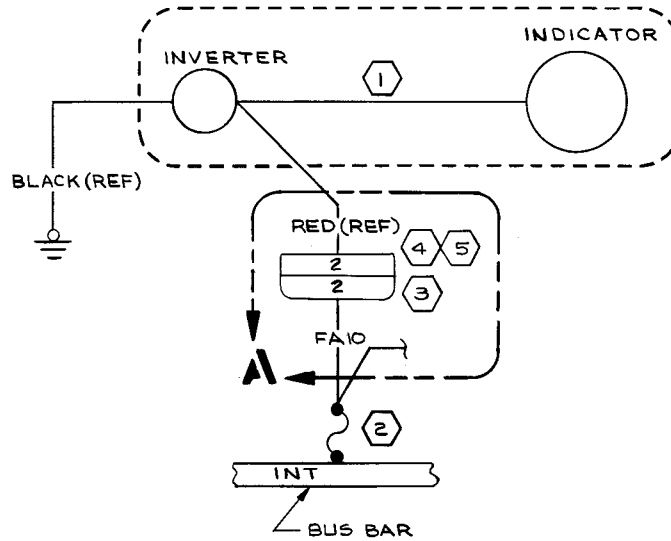

ITEM NO.	PART NO.	DESCRIPTION
5	S-1636-2	SOCKET
4	S-1641-6	HOUSING-SOCKET
3	S-1640-6	HOUSING-PIN
2	S-1091-10	FUSE
1	C661003-0401	TURN COORDINATOR

FAIO	WIRE CODE NO.	GA	MATERIAL	LG	TERMINALS	SERIALS
18				12	SOLDERS-1635-1	

CONTRACT NO:			WIRE TABLE		
DESIGN	W COOK	12-18-67	Cessna AIRCRAFT CO. COMMERCIAL AIRCRAFT DIV. 5800 E. PAWNEE WICHITA, KANSAS		
GROUP	H. W. W.	5-25-67	TITLE		
DRAWN	C. GARCIA	5/19/67	WIRING DIAGRAM - BRITAIN WING LEVELER (OPT)		
CHECK	YAKSHAW	5-22-67	SIZE	CODE IDENT. NO.	DWG NO.
STRESS	amb	5-25-67	C	71379	0410011
PROJECT	W. Little	5-25-67	SCALE: NONE (SR 5145) IX PAGE: 9.5		
APPD	R. E. M.	5-24-67			

INACTIVE:
ERE THEU SER (SR1555) 150755 294 1500 979
5-16-73
DLP
HAW
HAC

REVISION			
LET	DESCRIPTION	DATE	APPD
A	BY REV: ADD NOTE NO. 4 (SR 7692)	M.E.M. 3-5-74	JLO RF

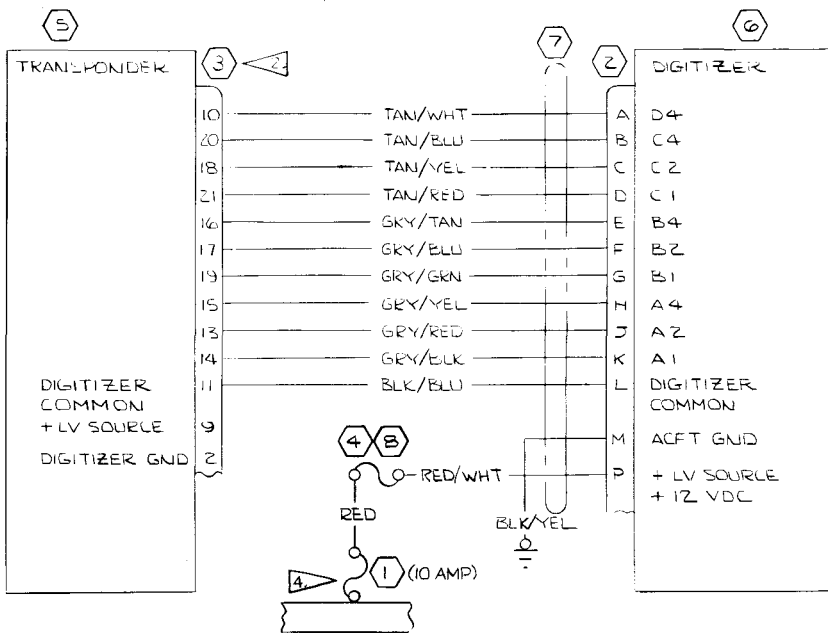

INACTIVE
EFF THRU
8-15-74
SER(SR7900)(SR7901)(SR7902)
BFC (15072000, A1500619)
RF

5060-522-00

NOTES:

- 1. PINS ARE CRIMP TYPE AND FURNISHED BY VENDOR WITH CONNECTOR.
- 2. TRANSPONDER CONNECTOR HOUSING IS PART OF TRANSPONDER CABLE ASSY.
- 3. FOR WIRING DIAGRAM OF 300 TRANSPONDER REFER TO 3920143.
- 4. ATTACH BOTH TRANSPONDER AND ENCODING ALTIMETER TO THE NO. 3 FUSE.

WIRE CODE NO.	GA	MATERIAL	LG	TERMINALS	SERIALS
BLK/YEL	22	-22-0-4		S-13671-8	
TAN/WHT	1	-22-10-9		S-2190-1	
TAN/BLU		-22-10-6			
TAN/YEL		-22-10-4			
TAN/RED		-22-10-2			
GRN/TAN		-22-8-10			
GRN/BLU		-22-8-6			
GRN/GRN		-22-8-5			
GRN/YEL		-22-8-4			
GRN/RED		-22-8-2			
GRN/BLK		-22-8-0			
BLK/BLU	22	-22-0-6		S-2190-1	
RED/WHT	20	-20-2-9		SOLDER	
RED	18	-18-2		SOLDER	

ITEM NO.	PART NO.	DESCRIPTION
8	155104	FUSE HOLDER
7	1570512-2	CABLE ASSY
6	EA-401A	ALT DIGITIZER
5	RT-359A	TRANSPONDER
4	SFE 4	FUSE
3	S-2189-1	CONNECTOR
2	42816	CONNECTOR
1	S-1091-10	FUSE

EQUIPMENT TABLE	
CES-1000 IS APPLICABLE VENDOR CODES PER S-1400 CES-XXXX-CESSNA SPEC. NO. S-XXX OR CMXXXX-CESSNA STD. NO.	SUPERSEDED BY: 0470401 9.3

WIRE TABLE		
CONTRACT NO:	COMMERCIAL AIRCRAFT DIV. 5800 E. PAWNEE WICHITA, KANSAS	
DESIGN	NAME	DATE
GROUP	W. J. OLIVER	11-12-73
DRAWN	J. OLIVER	11-9-73
CHECK	J. YOVEL	11-9-73
STRESS		
PROJ	J. YOVEL	11-19-73
APPD		
OTHER		
SIZE	CODE IDENT. NO.	DWG NO.
C	71379	0410011
SCALE: NONE	(SR 7692)	PAGE: 9.6

(15073732; A1500524)

Change 3 20-19

(SR 9021)

CHG LET	REVISION	BY DATE	CHK APPD
A	BY REV: ADD DETAIL A, DC5 & SERIALS. SERIALIZE OUT -DC1. (15061533) IS	4 PD 1-8-65	
B	BY REV: ON DETAIL A "TO TERMINAL 2 ON MASTER SW WAS PA9 (REF) (15061533)"	8 PD 10-8-65	
C	BY REV: S-1317N2 WAS S-1317N1	FER 4-16-69	
ED & RR 10418			
D	BY REV: SER OUT S-1579-1 & ADD S-1579-2 SR7201	BPH 6-16-72	
E	BY REV: ADD 6 & 7, DETAIL "B" & SERIAL (SR7301) & (SR7302)	JLO 5-21-73	
F	BY REV: ADD WIRE COLOR RED (DC6) WAS DC6; LG 18 WAS 9/RED (DC6) MER 150-E0044 (SR 7600) (REF)	JEF 5-13-74 BRF	

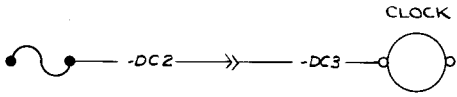

DETAIL B
THRU SER (SR7301) & (SR7302)
(A1500429) & (FA1500261)

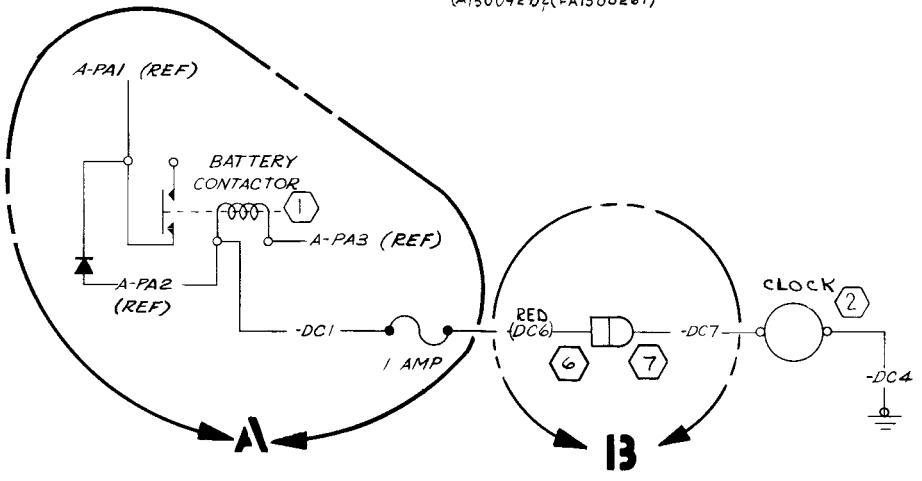

INACTIVE
EFF THRU SER (SR7301) (SR7302) (SR7302)
S-15-74
BRF (15077000, A1500619)
JEF
BRF

00-223-0905

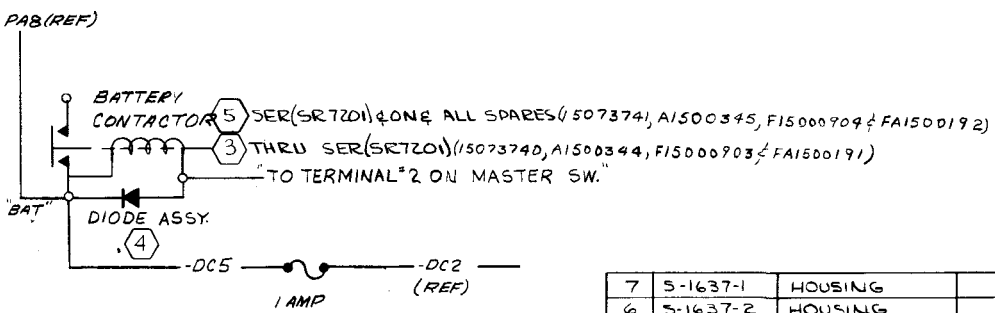

DETAIL A
(15061533) & ON

QTY	PART NO.	DESCRIPTION	INSTALLED ON
7	S-1637-1	HOUSING	
6	S-1637-2	HOUSING	
5	S-1579-2	CONTACTOR	
4	0770728-1	DIODE ASSY.	
3	S-1579-1	CONTACTOR	
2	S-1317N2	CLOCK ASSY	
1	0712603-2	CONTACTOR	

EQUIPMENT TABLE

WIRE CODE NO.	GA	MATERIAL	LG	TERMINALS	SERIALS
-DC7	18	66	S-1635-1	S-1367-1-6	OPT. SER (SR7301) & (SR7302) & ON ALL SPARES
RED (DC6)	18	18	S-1636-1	SOLDER	STD. SER (SR7301) & (SR7302) & ON ALL SPARES
-DC5	18	9	S-1367-1-3	SOLDER	OPT. 15061533 & ON
-DC4	18	3	S-1367-1-8	S-1367-1-6	OPTIONAL 15059770 & ON
-DC3	18	66	S-341-2	S-1367-1-6	OPT. SER 15059770 THRU SER (SR7301) & (SR7302)
-DC2	18	6	S-341-2	SOLDER	STD. SER 15059770 THRU SER (SR7301) & (SR7302)
-DC1	18	9	S-1367-1-6	SOLDER	OPT. 15059770 THRU 15061532

WIRE TABLE

CESSNA AIRCRAFT CO. COMMERCIAL AIRCRAFT DIVISION, WICHITA, KANSAS

DRAWN	NAME	DATE	TITLE
GROUP	SPRIGGS	10-9-62	WIRING DIAGRAM -
CHECK	PARSONS	10-12-62	CLOCK
PROJ	R. Stuck	10-11-62	
		10-15-62	

DWG NO: 0410011

SUPERSEDED BY: 0470401 P 10.1 MODEL: 150 REV: E PAGE: 10.1

NOTES:

1. TERMINALS OF WIRES FOR OPT EQUIPMENT SHALL BE PROTECTED AGAINST SHORTING WHEN OPT EQUIPMENT IS NOT INSTALLED.

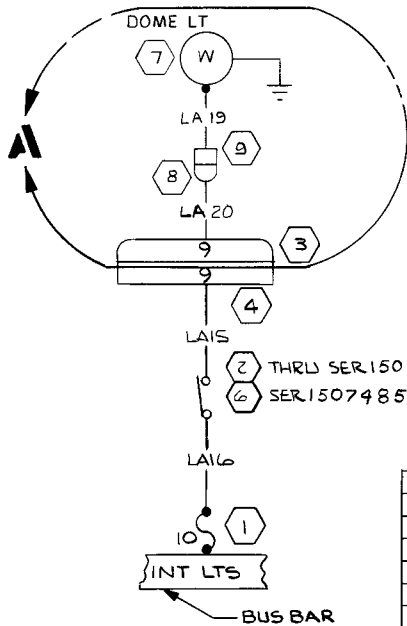
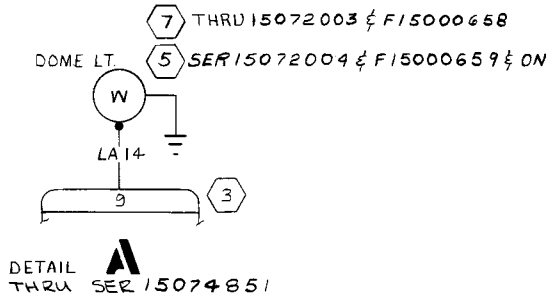

REVISION			
LET	DESCRIPTION	DATE	APPD
A	BY REV: ADD "9" AS TERMINATION REVERSE ITEMS 3 & 4 IN FIELD; TITLE WAS "COURTESY LIGHTS" ED & RR 01990 (SR543T) IX	3-27-68	RLY GKI MDS 11-20 7/2W D&K
B	BY REV: ADD WIRE LENGTHS (NOW SHOP PRACTICE)	3-15-73	DLO BY RW RF
C	BY REV: ADD S-2160-1 & SER; S-1824-1 WAS 0713029-0; S-1493-1/LAIS & LA16 WAS S1367-1-6 (SR7300) (S K730) (SR730Z) IX	7-24-73	DLO DLP RW RF
D	BY REV: ADD 0711737 WAS 0511481; S-1636-1 WAS S-1636-2/LA14; S-1635-1 WAS S-1635-2/LAIS; S-1636-1 WAS S-1635-1 REF LA15 & S-1635-1 WAS S-1636-1 REF LA14; ADD DETAIL A, LA 19 & LA 20; SOLDER WAS S-1635-1 (LA14) (SR 7300) (REF)		TDN SCY ARS 11-20 RW RF DEF M.E.M. 2-13-74
E	BY REV: 0470112-1 WAS 0711737-1 (SR6350) (REF) (MER 150-E0088)	4-10-74	MEM DLO RW RF 4-10-74
F	BY REV: LG 15/LAIS WAS S (NOW SHOP PRACTICE) MER 150-E0088	5-14-74	BRF DLO RW RF 5-14-74

INACTIVE
 EFF THRU SER (SR7900) (SR7901) (SR7902)
 8-15-74
 BRF (15077000, A1500614)
 JERRY ARS RW RF

ITEM NO.	PART NO.	DESCRIPTION
9	S-1637-1	HOUSING-PIN
8	S-1637-2	HOUSING-SOCKET
7	0470112-1	SUPPORT ASSY
6	S-2160-1	SWITCH
5	0511481-6	SUPPORT ASSY
4	S-1641-9	HOUSING-SOCKET
3	S-1640-9	HOUSING-PIN
2	S-1824-1	SWITCH
1	S-1091-10	FUSE

WIRE CODE NO.	GA	MATERIAL	LG	TERMINALS	SERIALS
LA 20	18		85	S-1635-1	SER 15074851 4 ON
LA 19	18		8	SOLDER S-1636-1	SER 15074851 4 ON
LA 16	18		6	SOLDER S-1493-1	
LA 15	18		15	S-1493-1	
LA 14	18		85	S-1635-1 SOLDER	THRU SER 15074851

EQUIPMENT TABLE	
ITEM NO.	DESCRIPTION
9	S-1637-1 HOUSING-PIN
8	S-1637-2 HOUSING-SOCKET
7	0470112-1 SUPPORT ASSY
6	S-2160-1 SWITCH
5	0511481-6 SUPPORT ASSY
4	S-1641-9 HOUSING-SOCKET
3	S-1640-9 HOUSING-PIN
2	S-1824-1 SWITCH
1	S-1091-10 FUSE

SUPERSEDES:	
0410011	P 11.1.2

SUPERSEDED BY:	
0470401	11.1

CONTRACT NO:		WIRE TABLE	
DESIGN	NAME	DATE	TITLE
W COOK		12-18-67	WIRING DIAGRAM - DOME LIGHT
HARRIS		12-18-67	
LAURIE		12-14-67	
dur		12-16-67	
D.G. Koller		12-22-67	
MARTEN		12-15-67	

SIZE	CODE IDENT. No.	DWG NO.
C	71379	0410011

SCALE:	PAGE:
NONE	11.1.3

REVISION			
LET	DESCRIPTION	DATE	APPD
A	BY REV: PICTURE CHANGE ONLY TO AGREE WITH PRODUCTION ED&RR 01990 (SR5437) IX	3-27-68	CKI MDS 1.20 N/W DCK

INACTIVE:
EFF SER (15069309)
THRU SER 15071128
FER ED&RR 10502A 4-10-69
JWH
MDS
1/20
N/W

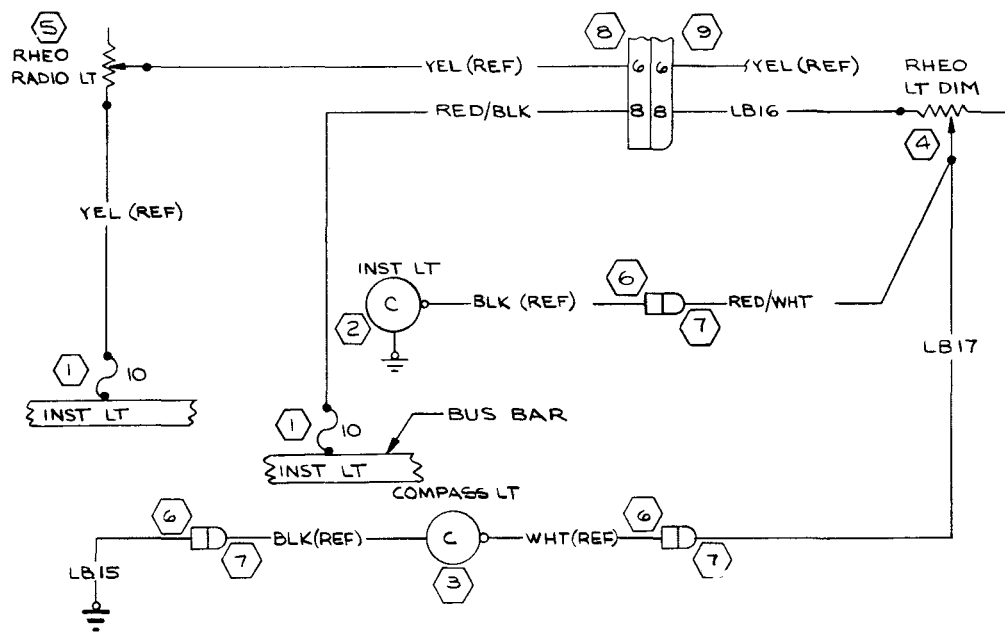

NOTES:

- INSTALL S-1635-1 PIN ON BLK WIRE OF COMPASS & S-1636-1 SOCKET ON WHITE OF COMPASS.
- INSTALL S-1636-2 SOCKET ON BLK WIRE OF INSTRUMENT LIGHT.

ITEM NO.	PART NO.	DESCRIPTION
9	S-1640-9	HOUSING-PIN
8	S-1641-9	HOUSING-SOCKET
7	S-1637-1	HOUSING-PLUG
6	S-1637-2	HOUSING-CAP
5	0413126-5	RHEOSTAT
4	0413126-6	RHEOSTAT
3	0713068-2	COMPASS LIGHT
2	0511481-6	INST LIGHT
1	S-1091-10	FUSE

WIRE CODE NO.	GA	MATERIAL	LG	TERMINALS	SERIALS
RED/WHT	18	-18-2-9		SOLDER	S-1635-2
RED/BLK	18	-18-2-0		SOLDER	S-1636-2
LB17	18			SOLDER	S-1635-2
LB16	18			SOLDER	S-1635-2
LB15	18			SOLDER	S-1636-2

WIRE TABLE

DESIGN GROUP	NAME	DATE
W	COOK	12-18-67
N	WILSON	12-18-67
H	HARRIS	12-6-67
C	LAURIE	12-19-67
S	STRESS	12-19-67
P	PROJECT	D.G. KULLER 12-10-67
A	APPD	MARTEN 12-15-67

COMMERCIAL AIRCRAFT DIV.
5800 E. PAWNEE
WICHITA, KANSAS

Cessna AIRCRAFT CO.

TITLE
WIRING DIAGRAM - INSTRUMENT LIGHTS

CONTRACT NO:
DRAWN: HARRIS 12-6-67
CHECK: LAURIE 12-19-67
STRESS: 12-19-67
PROJECT: D.G. KULLER 12-10-67
APPD: MARTEN 12-15-67

SIZE: C
CODE IDENT. NO.: 71379
DWG NO.: 0410011
SCALE: NONE
150
PAGE: 11.2.4

CES-1000 IS APPLICABLE
VENDOR CODES PER S-1400
CES-XXXX-CESSNA SPEC. NO.
S-XXX OR CMXXXX-CESSNA
STD. NO.

SUPERSEDES:
0410011 P. 11.2.3
SUPERSEDED BY:
P. 11.2.5

NOTES:

- THIS DRAWING IS STANDARD EQUIPMENT ON FRENCH AIRCRAFT AND OPTIONAL EQUIPMENT ON DOMESTIC.

REVISION			
LET	DESCRIPTION	DATE	APPD
A	BY REV: ADD DETAIL A & SER (SR7301) (SR7302) (SR7388) II	LES 11-17-72	LES RF
B	BY REV: ADD WIRE LENGTHS (NOW SHOP PRACTICE)	JLO 5-4-73	JLO RF
C	BY REV: LDG LT - RH WAS LH, TAXI LT - LH WAS RH (NOW SHOP PRACTICE)	TJP 12-6-73	TJP RF
D	BY REV: ADD NOTE 1 (NOW SHOP PRACTICE)	RJP 2-5-74	RJP RF

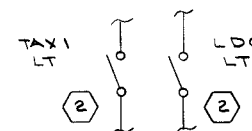
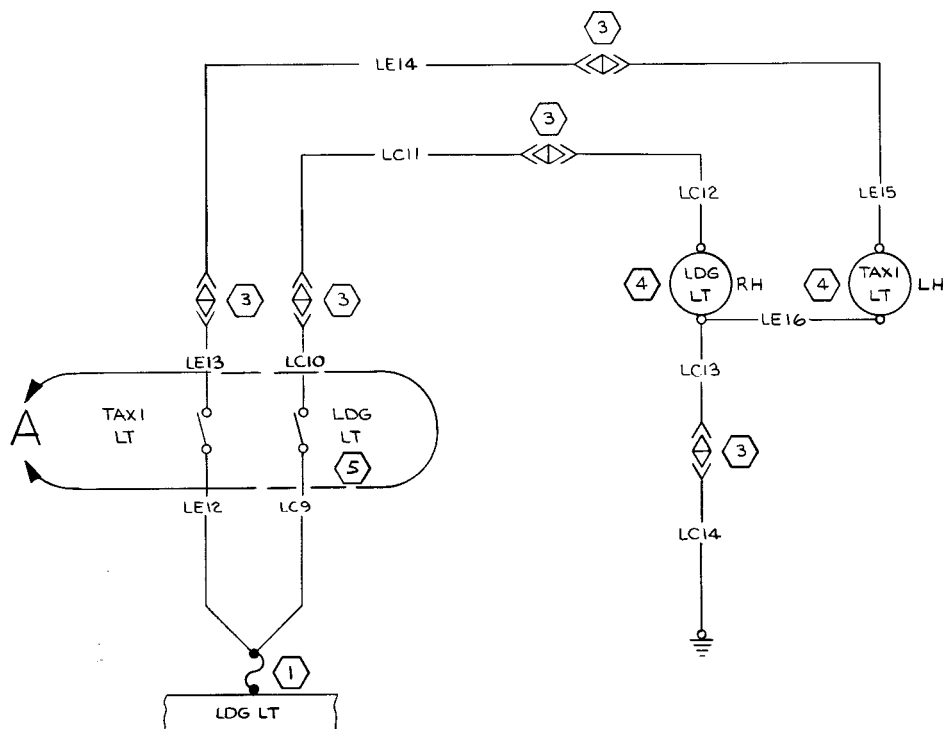

DETAIL A
EFF THRU SER (A1500430, FA1500211 & SR7388)

WIRE CODE NO	GA	MATERIAL	LG	TERMINALS	SERIALS
LE16	12			5-13673-8	5-13673-8
LE15	12			5-1493-3	5-13673-8
LE14	12			5-1493-3	5-1493-3
LE13	12			5-1493-3	5-1493-3
LE12	12			SOLDER	5-1493-3
LC14	12		12	5-1493-3	5-13673-6
LC13	12		46	5-13673-8	5-1493-3
LC12	12		46	5-1493-3	5-13673-8
LC11	12		34	5-1493-3	5-1493-3
LC10	12		9	5-1493-3	5-1493-3
LC9	12		9	SOLDER	5-1493-3

WIRE TABLE

PART NO.	DESCRIPTION
5	S-2160-4 SWITCH
4	4509 100 WATT PAR 36 LAMP (24446)
3	S-2064-1 CONNECTOR
2	S-2061-1 SWITCH
1	S-1091-25 FUSE

EQUIPMENT TABLE	
PART NO.	DESCRIPTION

CES-1000 IS APPLICABLE
VENDOR CODES PER S-1400
CES-XXXX*CESSNA SPEC. NO.
S-XXX OR CMXXXX*CESSNA
STD. NO.

SUPERSEDES:
SUPERSEDED BY:

CONTRACT NO:	
DESIGN	L.K. WHITE 8-29-72
GROUP	H. Wise 10-10-72
DRAWN	L.K. WHITE 10-9-72
CHECK	R. Youngers 10-9-72
STRESS	
PROJ	R. Wise 10-10-72
APPD	
OTHER	

COMMERCIAL AIRCRAFT DIV. 5800 E. PAWNEE WICHITA, KANSAS	
Cessna. AIRCRAFT CO.	
TITLE WIRING DIAGRAM— LANDING & TAXI LIGHTS (OPT)	
SIZE	CODE IDENT. NO.
C	71379
DWG NO	0410011
SCALE: NONE	SER 7316
PAGE: 11, 3, 4	

Change 2 20-22A/(20-22B blank)

This page intentionally left blank.

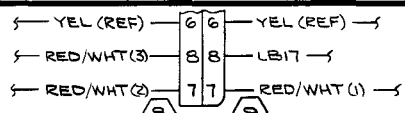

DETAIL A
THRU SER (15072003, A1500226, F15000658 & FA1500081)

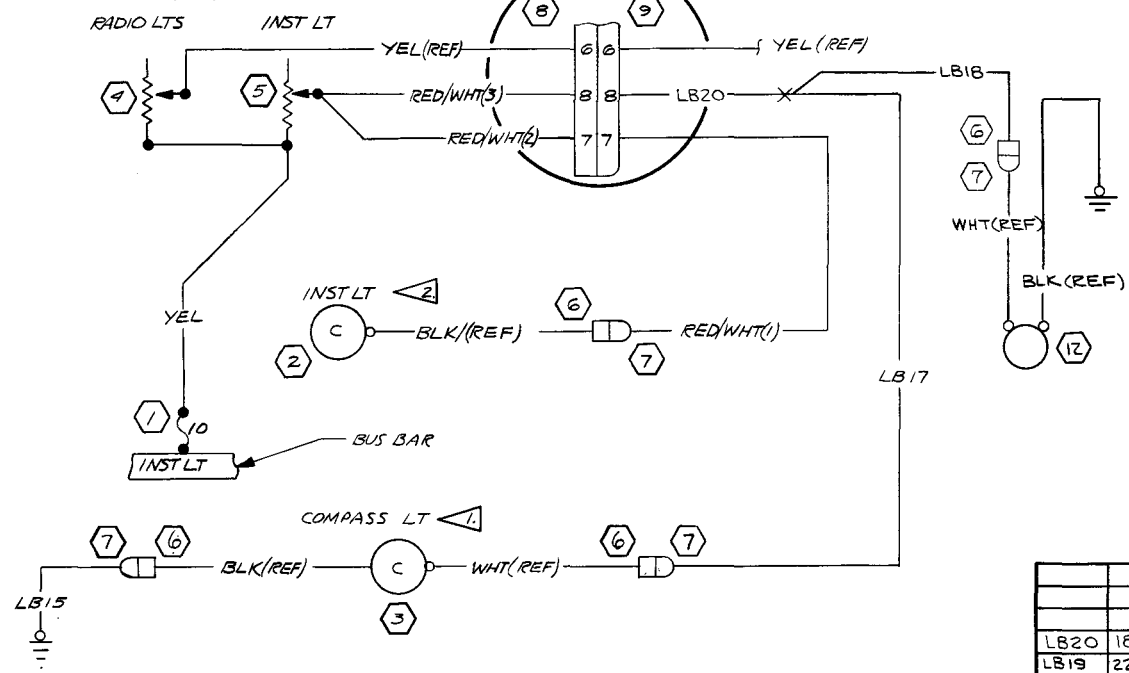

REVISION			
LET	DESCRIPTION	DATE	APPD
G	BY REV: S-1637-1 WAS S-1637-2 & S-1637-2 WAS S-1637-1; DELETE S-1638-2, S-1638-1 (NOW SHOP PRACTICE)	CMK 9-13-74	JCY APB MTH RF

REVISION			
LET	DESCRIPTION	DATE	APPD
A	BY REV: ON LB 15 S-1370-1 WAS S-1637-2 & S-1637-1; ON LB17 S-1370-1 WAS S-1637-2 & S-1637-2 DELETE NOTE 1 ED & RRR 10770	J.D. RAWES 10/28/69	JWH MDS HRW RF
B	BY REV: ADD LB18, LB19, S-1638-1, S-1638-2, 21820, DETAIL 'A' & SER ED & RRR 10089	RLV 7-6-70	LKW RLV JFW RF
C	BY REV: ADD WIRE LENGTHS (NOW SHOP PRACTICE)	JLO 5-3-73	JW YFW RF
D	BY REV: S-1636-1 & S-1367-1-8 WERE S-1370-1 & S-1367-1-14/LB15, S-1635-2 WAS S-1635-1/LB17; ADD LB20 & WIRE LENGTHS TO LB19 & YELLOW (NOW SHOP PRACTICE)	RAM 3-2-74	SCJ JRS MTH RF
E	BY REV: OBSOLETE NEVER USED LB19 & DELETE DETAIL 'B' (SR7300)(REF) (SR7301)(REF)	RS 4-3-74	MTM JRS MTH RF
F	BY REV: C660501-0101 WAS 071306B-2 (NOW SHOP PRACTICE) (SR6022)(REF)	JLO 6-20-74	JCY APB MTH RF

INACTIVE
EFF THRU SER (SR7300)(SR7301)(SR7302)
B-15-74 BRF (15077000, A1500614)

- NOTES:
- 1. INSTALL S-1635-1 PIN ON BLK WIRE OF COMPASS AND S-1636-1 SOCKET ON WHITE OF COMPASS.
 - 2. INSTALL S-1636-2 SOCKET ON BLK WIRE OF INSTRUMENT LIGHT.

ITEM NO.	PART NO.	DESCRIPTION	QUANTITY
12	21820	LAMP (2AAA6)	
9	S-1640-9	HOUSING-PIN	
8	S-1641-9	HOUSING-SOCKET	
7	S-1637-1	HOUSING-CAP	
6	S-1637-2	HOUSING-PLUG	
5	S-1880-2	RHEOSTAT	
4	S-1880-1	RHEOSTAT	
3	C660501-0101	COMPASS ASSY	
2	051481-6	INST LIGHT	
1	S-1091-10	FUSE	

ITEM NO.	PART NO.	DESCRIPTION	QUANTITY
	LB20	18	6
	LB19	22	8
	LB18	22	60
	YELLOW	18 -18-4	8
	RED/WHT(3)	18 -18-2-9	10
	RED/WHT(2)	18 -18-2-9	10
	RED/WHT(1)	18 -18-2-9	80
	LB17	18	50
	LB15	18	15

EQUIPMENT TABLE	
ITEM NO.	DESCRIPTION
	CES-1000 IS APPLICABLE VENDOR CODES PER S-1400 CES-XXXX-CESSNA SPEC. NO. S-XXX OR CMXXXX-CESSNA STD. NO.
	SUPERSEDES: P. 11, 2, 4
	SUPERSEDED BY: 0470401 P 11.2

WIRE TABLE			
CONTRACT NO.	NAME	DATE	TITLE
	SIPE'S VR	4-2-69	WIRING DIAGRAM - INSTRUMENT LIGHTS
	GROUP	K. WOOD	
	DRAWN	F. RUNNER	
	CHECK	J. HARRIS	
	STRESS	W. HARRIS	
	PROJ	K. WOOD	
	APPD	M. SWANEY	
	OTHER		
SIZE	CODE IDENT. NO.	DWG NO.	
C	71379	0410011	
SCALE:	NONE	150, A150, F150, FA150	PAGE: 11.2.5

ED & RRR 10502A (SR60401) (SR6070) (1507129) (A150001, F1500001)

Change 3 20-23

NOTES:

- TERMINALS OF WIRES FOR OPT EQUIPMENT SHALL BE SUITABLY PROTECTED AGAINST SHORTING WHEN OPT. EQUIPMENT IS NOT INSTALLED.

SER 15064533 A ON

CHG LET	REVISION	BY	CHK
		DATE	APPD
A	BY REV: ADD LCB, LE6, LE9, LE10, LE11, S-1640-9, S-1641-9, S-1824-1 & DETAIL A & SER: SER OUT LCG, LCT & LES ED & RR 00948 (SR5437) 14	JWH	RLL
		12-6-65	1/2W 1/2W 1/2W

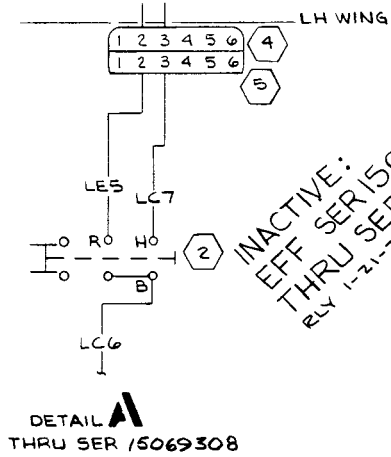
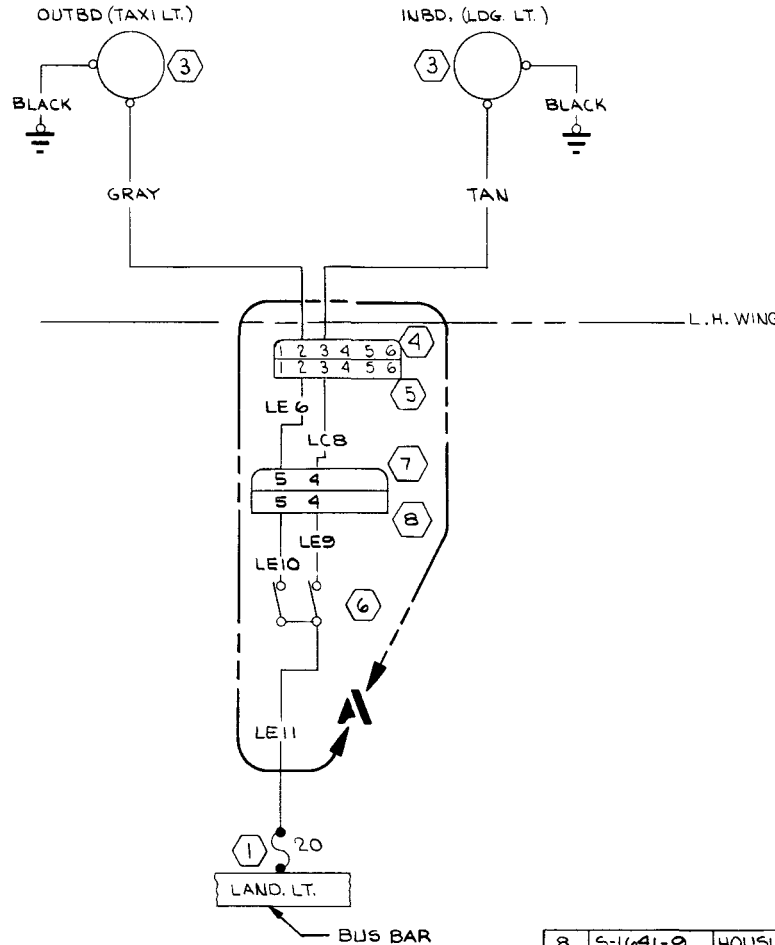

INACTIVE:
EFF SER 15064533
THRU SER 15072003
ED & RR 10827
JWH
1/2W
1/2W
1/2W

WIRE CODE NO.	GA	MATERIAL	LG	TERMINALS	SERIALS
LE 11	14			SOLDER S-493-2	
LE 10	14			S-1493-2 S-1636-2	
LE 9	14			S-1493-2 S-1636-2	
LE 6	14			S-1635-2 S-1636-2	
LCB	14			S-1635-2 S-1636-2	
GRAY	14	S-1460-14-8		S-1635-2 S-1367-2-8	STD.
TAN	14	S-1460-14-10		S-1635-2 S-1367-2-8	STD
BLACK	16	S-1460-16-0		S-1367-2-8 S-1367-2-8	0400314
BLACK	16	S-1460-16-0		S-1367-2-8 S-1367-2-8	0400314
LES	14			S-1367-2-8 S-1636-2	STD. THRU SER(SR5437)
LCT	14			S-1367-2-8 S-1636-2	STD THRU SER(SR5437)
LCG	14			SOLDER S-1367-2-8	0400314 THRU SER(SR5437)

ITEM NO	PART NO.	DESCRIPTION	INSTALLED ON
8	S-1641-9	HOUSING-SOCKET	
7	S-1640-9	HOUSING-PIN	
6	S-1824-1	SWITCH	
5	S-1641-6	HOUSING-SOCKET	
4	S-1640-6	HOUSING-PIN	
3	0523118-1	LIGHT INSTL	
2	0713035	SWITCH ASSY.	
1	S-1091-20	FUSE	

WIRE TABLE			
CESSNA AIRCRAFT CO., COMMERCIAL AIRCRAFT DIVISION WICHITA, KANSAS			
DRAWN	NAME	DATE	TITLE
BLISS		10-8-65	WIRING DIAGRAM -
		10-29-65	LANDING & TAXI
		10-30-65	LIGHTS
		11-2-65	(OPTIONAL)
SUPERSEDED BY:		SUPERSEDES	MODEL:
P.11.3.3		0410011 Pg.11.3.1	150
REV: A		PAGE: 11.3.2	



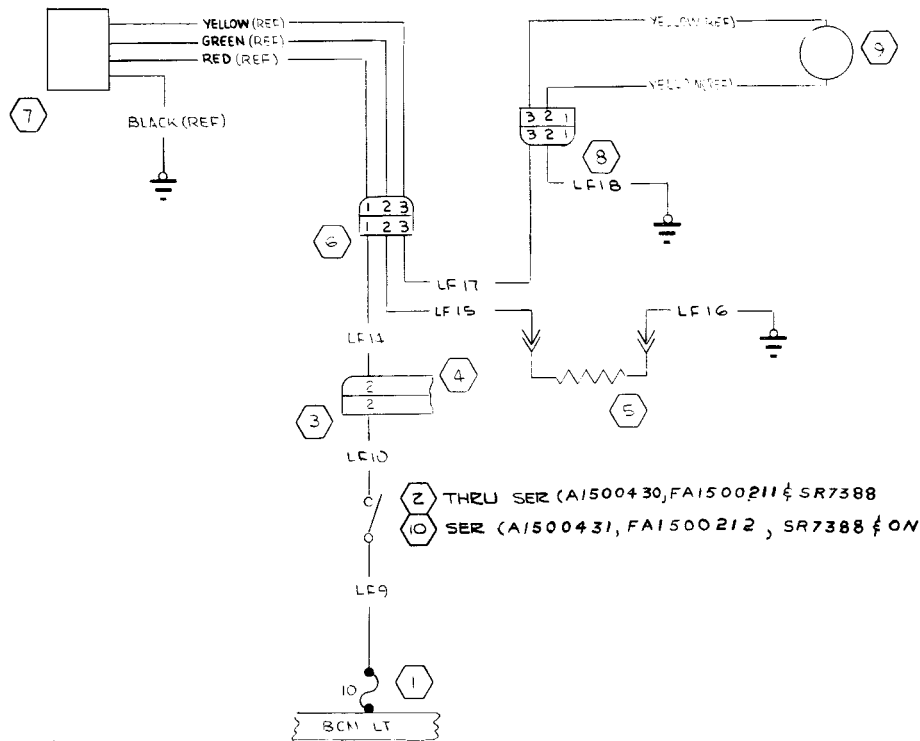

REVISION			
LET	DESCRIPTION	DATE	APPD
A	BY REV: ADD S-2160-1 FUSE; SER OUT S-1824-1, C621001-0106 WAS C621001-0103 (SR7301) (SR7302) (SR7308) II	DLP 1-10-73	DY H/W RF
B	BY REV: ADD WIRE LENGTHS (NOW SHOP PRACTICE)	JLO 5-4-73	DY H/W RF
C	BY REV: ADD WIRE LENGTH TO LF14 (NOW SHOP PRACTICE)	TDN 1-9-74	DY H/W RF

WIRE CODE NO.	GA	MATERIAL	LG	TERMINALS	SERIALS
LF18	16	8	S-1635-2	S-1367-8	
LF17	16	75	S-1635-2	S-1636-2	
LF6	16		S-1493-2	S-1367-2-8	
LF15	16		S-1493-2	S-1636-2	
LF14	16	240	S-1635-2	S-1636-2 (STD)	
LF10	16	6	S-1493-2	S-1636-2	
LF9	16	5	SOLDER	S-1493-2	

PART NO.	DESCRIPTION
10	S-2160-1 SWITCH
9	C621001-0106 LIGHT ASSY
8	S-1638-2 HOUSING-CAP
7	(S94507-0101) FLASHER ASSY
6	S-1638-1 HOUSING-PLUG
5	OR95-15 RESISTOR (8377)
4	S-1640-9 HOUSING-PIN
3	S-1641-9 HOUSING-SOCKET
2	S-1824-1 SWITCH
1	S-1091-10 FUSE

ITEM NO.	PART NO.	DESCRIPTION
EQUIPMENT TABLE		

CONTRACT NO:		WIRE TABLE	
NAME	DATE	TITLE	
DESIGN	COOK 6-16-72	Cessna AIRCRAFT CO. COMMERCIAL AIRCRAFT DIV. 5800 E. PAWNEE WICHITA, KANSAS	
GROUP	H. White 6-22-72	WIRING DIAGRAM — LIGHT-FLASHING BEACON (OPTIONAL)	
DRAWN	COOK 6-16-72	SIZE	CODE IDENT. NO. 71379
CHECK	WHITE 6-19-72	DWG NO.	J410011
STRESS	Patt 27 Jun 72	SCALE: NONE	150
PROJ	Patt 7-5-72	PAGE: 11.6.1	
APPD		(1:1000) (SR7001) (SR7162)	
OTHER			

CES-1000 IS APPLICABLE
VENDOR CODES PER S-1400
CES-XXX-CESNA SPEC. NO.
S-XXX OR CMXXX-CESNA
STD. NO.

SUPERSEDES:
P 11.6

SUPERSEDED BY:

Change 2 20-24A/(20-24B blank)

This page intentionally left blank.



NOTES:

- 1. THIS DRAWING IS APPLICABLE TO DOMESTIC AIRCRAFT ONLY.

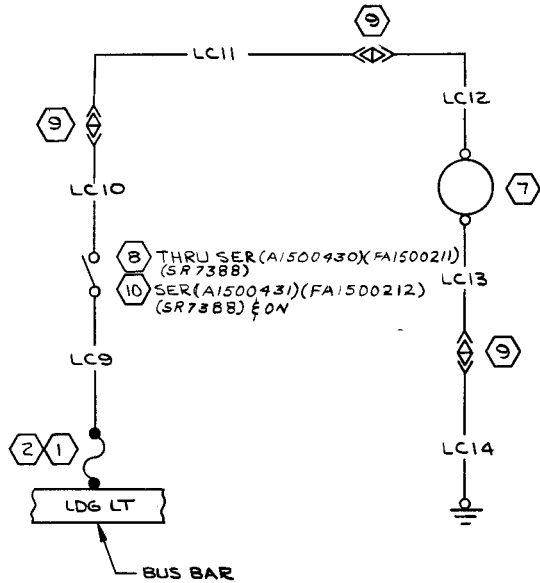

REVISION			
LET	DESCRIPTION	DATE	APPD
A	BY REV: DELETE S-1637-1 & S-1637-2; S-1493-2 WAS S-1635-2 & S-1636-2; 4313 WAS 4509; S-1091-25 WAS S-1091-10; S-1090-6 WAS S-1090-3 & S-2061-1 WAS S-1824-1 ED & RR 10085 (SR6350) & (SR6351) IX	RLY 7-6-70	LW RF
B	BY REV: 12 GA WAS 14 GA; S-1493-3 WAS S-1493-2; S-1367-3-X WAS S-1367-2-X; S-1493-3 WAS S-1636-2/LC10 & S-1635-2/LC11; DELETE S-1640-9 & S-1641-9 ED & RR 10098 (SR6350) & (SR6351) IX	RLY 7-20-70	LW RF
C	BY REV: SER OUT S-2061-5 & SER IN S-2160-5 (SR7301) (SR7302) (SR7388) IX	LES 11-17-72	RJW RF
D	BY REV: ADD WIRE LENGTHS (NOW SHOP PRACTICE)	JLO 3-15-73	RJW RF
E	BY REV: ADD NOTE 1 (NOW SHOP PRACTICE)	RJP 2-5-74	RJS RF

INACTIVE
EFF THRU SER (SR7900) (SR7901) (SR7902)
8-15-74 BRP (15077000, A1500614)
JOM
RJS
RF

5060-823-00

ITEM NO.	PART NO.	DESCRIPTION	VENDOR
10	S-2160-5	SWITCH	
9	S-2064-1	CONNECTOR	
8	S-2061-1	SWITCH	
7	4313	LAMP	(24446)
6			
5			
4			
3			
2	S-1090-6	FUSEHOLDER	
1	S-1091-25	FUSE	

WIRE CODE NO.	GA	MATERIAL	LG	TERMINALS	SERIALS
LC14	12		12	S-1493-3 S-1367-3-6	
LC13	12		46	S-1367-3-8 S-1493-3	
LC12	12		46	S-1493-3 S-1367-3-8	
LC11	12		34	S-1493-3 S-1493-3	
LC10	12		9	S-1493-3 S-1493-3	
LC9	12		9	SOLDER S-1493-3	

EQUIPMENT TABLE	
CES-1000 IS APPLICABLE VENDOR CODES PER S-1400 CES-XXX-CESSNA SPEC. NO. S-XXX OR CMXXX-CESSNA STD. NO.	SUPERSEDES: P 11.3.2 SUPERSEDED BY: 0470401 P 11.3

WIRE TABLE	
CONTRACT NO:	
DESIGN	W Ceoic 1-22-70
GROUP	H. Will 1-22-70
DRAWN	R. YOUNGERS 1-21-70
CHECK	HARRIS 1-21-70
STRESS	
PROJ	R. F. J. 1-23-70
APPD	R. YOUNGERS 1-22-70
OTHER	
SIZE	CODE IDENT. NO. 71379
DWG NO	0410011
SCALE: NONE	150 & A150
PAGE: 11.3.3	

(SR6350) & (SR6351) IX
(15072004; A150027) (15000659; FA15000B1) ED & RR 10867

Change 3 20-25

NOTES:

- THIS DRAWING IS STANDARD EQUIPMENT ON FRENCH AIRCRAFT AND OPTIONAL EQUIPMENT ON DOMESTIC.

REVISION			
LET	DESCRIPTION	DATE	APPD
A	BY REV: ADD DETAIL A & SER (SR7301) (SR7302) (SR7388) II	LES 11-17-72	RF
B	BY REV: ADD WIRE LENGTHS (NOW SHOP PRACTICE)	JLO 5-4-73	RF
C	BY REV: LDG LT-RH WAS LH, TAXI LT-LH WAS RH (NOW SHOP PRACTICE)	TJP 12-6-73	RF
D	BY REV: ADD NOTE I (NOW SHOP PRACTICE)	RJP 2-5-74	RF

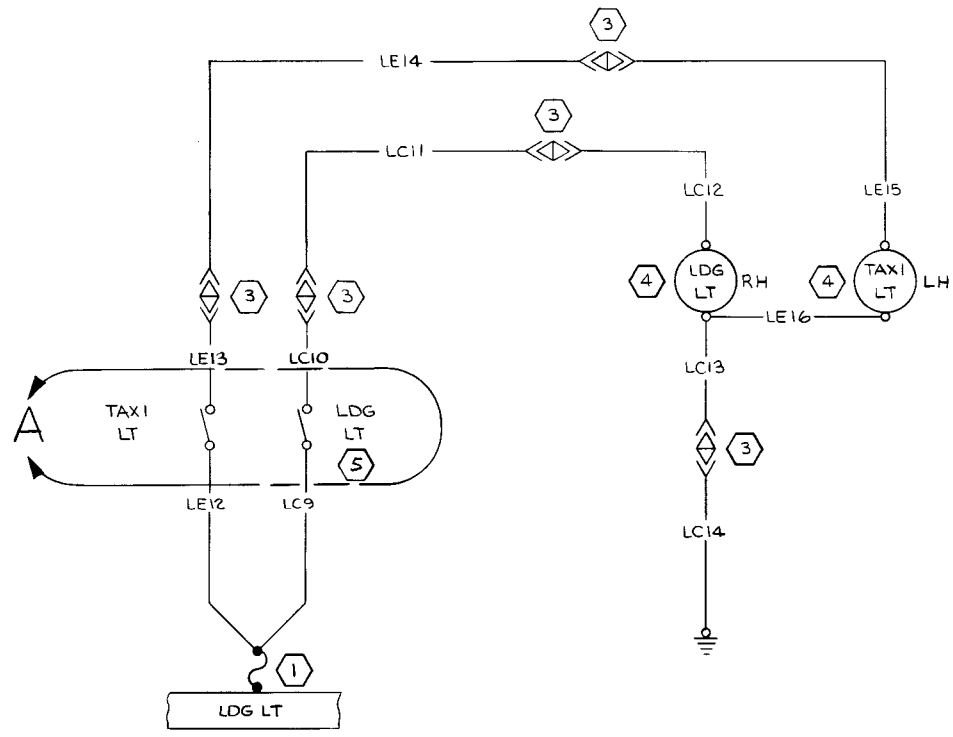

INACTIVE
EFF THRU SER (SR7900) (SR7901) (SR7902)
8-13-74 BRF (15077000, A1500614)

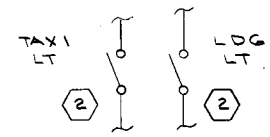

DETAIL A
EFF THRU SER (A1500430, FA1500211 & SR7388)

WIRE CODE NO	GA	MATERIAL	LG	TERMINALS	SERIALS
LE16	12			S-13673-8	S-13673-8
LE15	12			S-1493-3	S-13673-8
LE14	12			S-1493-3	S-1493-3
LE13	12			S-1493-3	S-1493-3
LE12	12			SOLDER	S-1493-3
LC14	12		12	S-1493-3	S-13673-6
LC13	12		40	S-13673-8	S-1493-3
LC12	12		40	S-1493-3	S-13673-8
LC11	12		34	S-1493-3	S-1493-3
LC10	12		9	S-1493-3	S-1493-3
LC9	12		9	SOLDER	S-1493-3

ITEM NO	PART NO.	DESCRIPTION
5	S-2160-4	SWITCH
4	4509	100 WATT PAR 36 LAMP (24446)
3	S-2064-1	CONNECTOR
2	S-2061-1	SWITCH
1	S-1091-25	FUSE

EQUIPMENT TABLE	
CES-1000 IS APPLICABLE VENDOR CODES PER S-1400 CES-XXXX-CESSNA SPEC. NO. S-XXX OR CMXXXX-CESSNA STD. NO.	SUPERSEDED BY: 0470401 11.3

WIRE TABLE		
CONTRACT NO:		COMMERCIAL AIRCRAFT DIV. 5800 E. PAWNEE WICHITA, KANSAS
DESIGN	L.K. WHITE	8-29-72
GROUP	H. W. Weil	10-10-72
DRAWN	L.K. WHITE	10-9-72
CHECK	R. Youngers	10-9-72
STRESS		
PROJ	R. J. Fife	10-11-72
APPD		
OTHER		
SIZE	CODE IDENT. NO. C 71379	DWG NO. 0410011
SCALE: NONE	(SR 7316)	PAGE: 11.3.4

(15074851; A1500431; F1500104; FA1500212)

5060-532-00

SER/5064533

CHG LET	REVISION	BY	CHK	CHG	REVISION	BY	CHK
DATE		DATE	APPD	LET		DATE	APPD
H	BY REV: LD 34 WAS LD 28; 5 WAS 3/LD 34; 85 WAS 70/LD 26. ADD WIRE LENGTHS TO LD 23, LD 22 AND LD 21. NOW SHOP PRACTICE (MERISO-EO 324)	CMK	ST	A	BY REV: DELETED PBB (REF) FROM NAV LTS SWITCH (SR 5199)	ST	ST
		9-13-74		B	BY REV: ADD 5-1640-9, LD 21, LD 22, LD 23, LD 24, S-1641-9, S-1824-1 & DETAIL A & SER, SER OUT LD 16, LD 17, LD 18 & LD 19, C622001-0202 WAS 0423006-21 & 22, C622001-0102 WAS 0433006-7, ITEM 3 WAS ITEM 5 & LD 26 WAS LD 14; ADD LD 20, LD 25, S-1637-1, S-1637-2; DELETE 3 RED WIRES & 3 BLACK WIRES FROM WIRE TABLE ED & RR 00948 (SR 5437) IX ED & RR 01163 & ED & RR 01335 (506823)	JUDH	RLT
				C	BY REV: ADD LD 27; RED WIRE WAS LD 20 & RED WIRE WAS LD 25 ED & RR 01990 & 01999 (SR 5437) IX	RLY	GKI
				D	BY REV: ADD DETAIL B ED & RR 03435 (SR 5437) IX	FER	MDS
				E	BY REV: SER OUT S-1824 & SER IN S-2160-1 (SR 7301) (SR 7302) (SR 7303)	LES	RF
				F	BY REV: ADD WIRE LENGTHS (NOW SHOP PRACTICE)	JLO	RF
				G	BY REV: S-1640-9 & S-1641-9 WERE S-1640-6 & S-1641-6; ADD LD 28; S-1370-2 WAS S-1635-1/LD 21, LD 22 & LD 23; S-1635-1 WAS S-1636-1/RED(1) & RED(2); S-1636-1 WAS S-1635-1/21; ADD S-1638-2 & S-1638-1 (NOW SHOP PRACTICE) (MERISOEO 229)	BAH	JEF

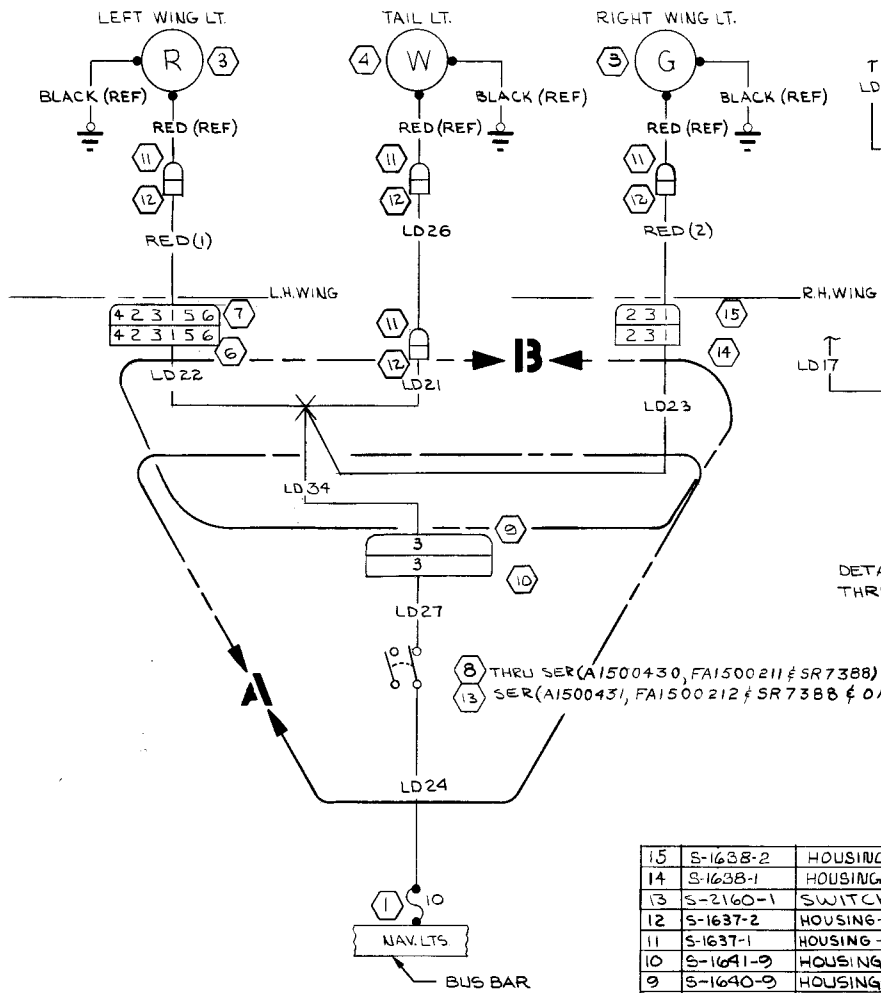

DETAIL 13
THRU SER 15069308

DETAIL A
THRU SER 15069308

INACTIVE
EFF THRU SER (SR 7900) (SR 7901) (SR 7902)
8-15-74
SRF (15077009, A1500690)

00-225-0905

ITEM NO	PART NO.	DESCRIPTION	INSTALLED ON
15	S-1638-2	HOUSING	
14	S-1638-1	HOUSING	
13	S-2160-1	SWITCH	
12	S-1637-2	HOUSING-SOCKET	
11	S-1637-1	HOUSING-PIN	
10	S-1641-9	HOUSING-SOCKET	
9	S-1640-9	HOUSING-PIN	
8	S-1824-1	SWITCH	
7	S-1641-6	HOUSING-SOCKET	
6	S-1640-6	HOUSING-PIN	
5			
4	C622001-0102	TAIL LIGHT ASSY	
3	C622001-0202	LIGHT ASSY	
2	0T13026-4	SWITCH ASSY.	
1	S-1091-10	FUSE	

LD NO	TERMINALS	WIRE NO	TERMINALS	SERIALS
LD 34	18	5	S-1635-1	SEE LD 21
LD 22	18	52	SEE LD 21	S-1635-1
LD 21	18	251	S-1370-2	S-1636-1
LD 27	18	5	S-1493-1	S-1636-1
LD 26	18	85	S-1635-1	S-1636-1
RED(1)	18	190	S-1635-1	S-1636-1
LD 24	18	6	SOLDER	S-1493-1
LD 23	18	61	SEE LD 21	S-1636-1
LD 22	18	52	SEE LD 21	S-1636-1
LD 21	18	251	S-1370-2	S-1636-1
RED(1)	18	190	S-1635-1	S-1636-1
LD 19	18		S-1367-1-8	S-341-2
LD 18	18		S-1367-1-8	S-1636-2
LD 17	18		S-1367-1-8	S-1636-2
LD 16	18		SOLDER	S-1367-1-8
LD 14	18	80	S-341-2	SOLDER

WIRE TABLE			
CESSNA AIRCRAFT CO., COMMERCIAL AIRCRAFT DIVISION, WICHITA, KANSAS			
DRAWN	NAME	DATE	TITLE
BLISS		10-8-65	WIRING DIAGRAM -
GROUP	W. H. H.	10-29-65	NAVIGATION
CHECK	C. H. H.	10-30-65	LIGHTS
PROJ	P. H. H.	11-2-65	
SUPERSEDED BY:		SUPERSEDES:	
0470401 P 11.4		041011 PG 11.4.1	
MODEL:		150	
DWG NO:		0410011	
REV:		H PAGE: 11.4.2	

Change 3 20-27

(SR 4920)

CHG LET	REVISION	BY	CHK	DATE	APPD
A	BY REV. IN U/I 5-1091-15 WAS 5-1091-10 IN WIT LFT (OPT) & LF8 (OPT) WAS LFT (STD) & LF8 (STD)	JWH	RLY	7-20-66	YAK
B	BY REV: ADD 5-1640-9, 5-1641-9, 5-1824-1, LF9, LF10, LF11 & DETAIL A & SER; SER OUT LFS & LFG. ED & RR 00948 (SR 5437) II	JWH	RLY	12-12-68	YAK
C	BY REV: ADD DETAIL B & C C594501-0203; SER IN C594501-0201; 0203 & C621001-0103 ED & RR 10536 (SR 6264); (SR 5307) (SR 5412)	P&P	RLY	7-23-69	YAK
D	BY REV: ADD DETAIL D, LF12, LF13 & ZR-075-11.5 ED & RR 10882 (SR 6265)	P&P	RLY	3-6-70	YAK
E	BY REV: C621001-0106 WAS C621001-0103	DLP	RLY	1-17-73	YAK
F	BY REV: ADD WIRE LENGTHS (NOW SHOP PRACTICE)	JLO	RLY	3-16-73	YAK

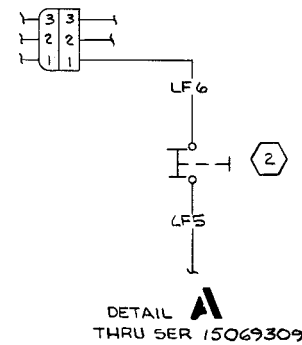
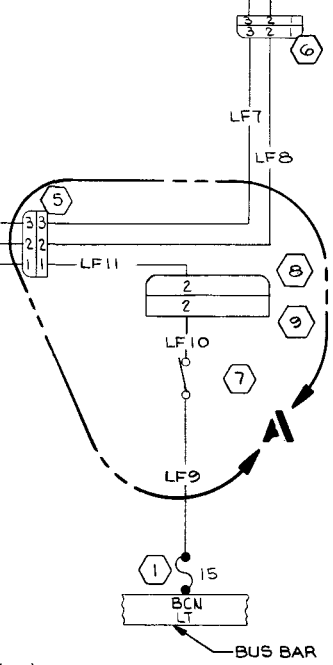
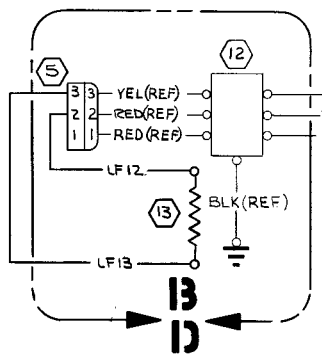
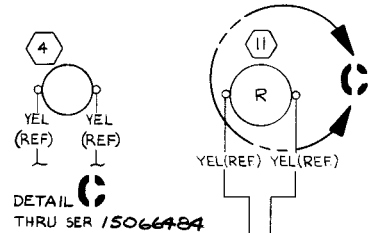
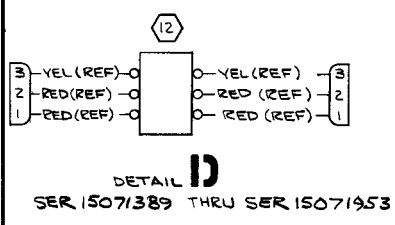

INACTIVE
EFFECTIVE SER 15064533 THRU SER 15073658
(A1500342) & (A1500166)
REV 6-16-72
NEW WIRE LENGTHS
DATE REF

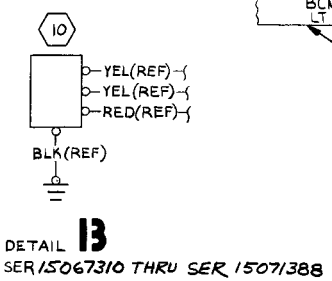
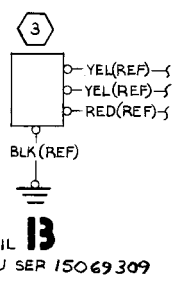

ITEM NO	PART NO.	DESCRIPTION	INSTALLED ON
13	ZR-075-11.5	RESISTOR (83777)	
12	C594501-0203	FLASHER ASSY	
11	C621001-0106	LIGHT ASSY	
10	C594501-0201	FLASHER ASSY-14V	
9	5-1641-9	HOUSING-SOCKET	
8	5-1640-9	HOUSING-PIN	
7	5-1824-1	SWITCH	
6	5-1638-2	HOUSING-CAP	
5	5-1638-1	HOUSING-PLUG	
4	C621001-0101	LIGHT ASSY-14V	
3	C594501-0101	FLASHER ASSY-14V	
2	0T13026-4	SWITCH ASSY	
1	5-1091-15	FUSE	

WIRE CODE NO.	GA	MATERIAL	LG	TERMINALS	SERIALS
LF13	16		4	5-1636-2 5-1493-2	(15071854; A1500217; FA1500046)
LF12	16		6	5-1636-2 5-1493-2	SER(SR6265) & ON
LF11	16		240	5-1635-2 5-1636-2	SER(SR6265) & ON
LF10	16		6	5-1493-2 5-1636-2	
LF9	16		5	SOLDER 5-1493-2	
LF8	16		75	5-1636-2 5-1635-2 OPT	
LF7	16		75	5-1636-2 5-1635-2 OPT	(15069308; F15000389)
LF6	16		5-1367-8	5-1636-2 STD.	THRU SER(SR5437)
LF5	16			SOLDER 5-1367-8 OPT	THRU SER(SR5437)

WIRE TABLE			
CESSNA AIRCRAFT CO., COMMERCIAL AIRCRAFT DIVISION, WICHITA, KANSAS			
DRAWN	NAME	DATE	TITLE
	BLISS	12-10-65	WIRING DIAGRAM - LIGHT-FLASHING BEACON (OPTIONAL)
GROUP	R. Wick	12-20-65	
CHECK	R. Wick	12-20-65	
PROJ.	Hubb	12-21-65	
SUPERSEDED BY: P 11.6.1		SUPERSEDES: 041001 PP 11.5	
MODEL: 150		REV: E	PAGE: 11.6



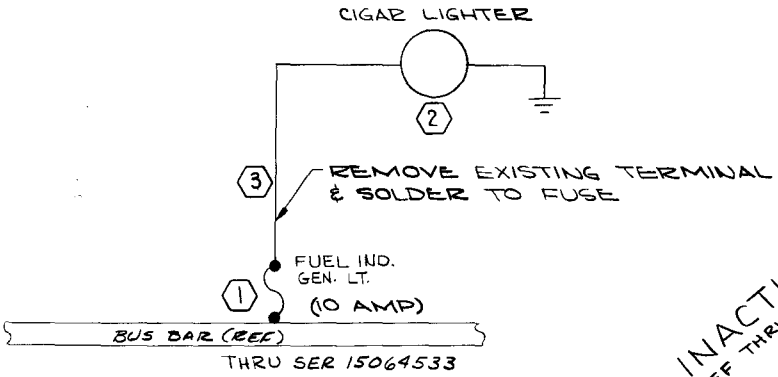
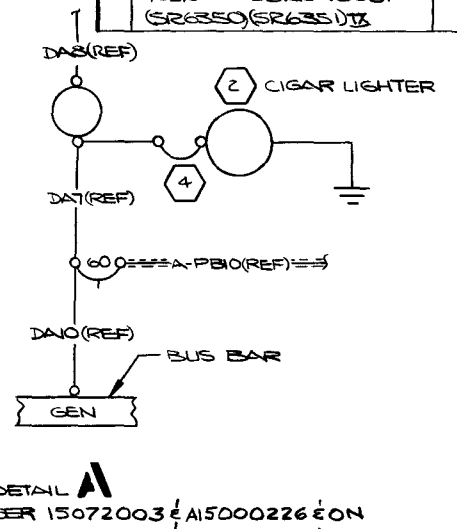
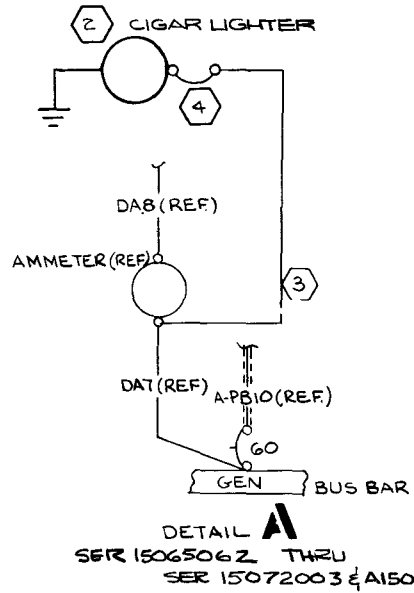
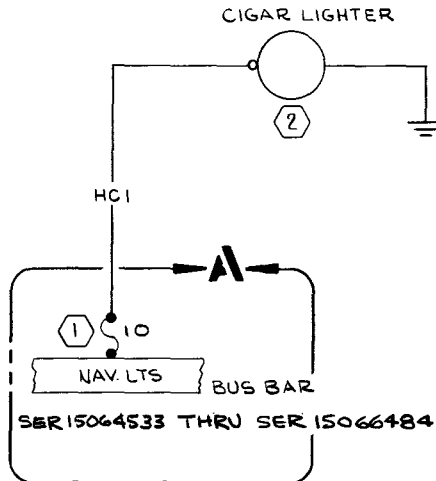

CHG LET	REVISION	BY	CHK
		DATE	APPD
B	REDRAWN NO CHG	8-28-62	ERS
C	ADDED E/T; ADDED HCI TO W/T & ADDED LIMITING SERIALS; FUEL IND. GEN LT. WAS DOME LT FUSE; (15064533)	9-27-62	ERS
D	BY REV; ADD 60232-1 TO E/T; ADD DETAIL A TO FLD; IN W/T HCI SERIALIZED OUT; 0513052-3 WAS 0513039-7 IN E/T (SR 5133)	7-20-66	YAK
E	BY REV: SER OUT DETAIL 'A'; ADD DETAIL 'A' & SER ED RR 10021 (SR 6350) (SR 6351) (SR 6352)	4-29-70	DLP

INACTIVE:
EFF THRU SER (SR7690) (15073564; F1500143,
10-11-73 A1500480 & FA1500261)

RAM
JLP
ZRW
RWS
RF

WIRE CODE NO.	GA	MATERIAL	LG	TERMINALS	SERIALS
HCI	16			SOLDER 5-136T-2-8	(15064533) THRU (SR 5153)

WIRE TABLE

CESSNA AIRCRAFT CO COMMERCIAL AIRCRAFT DIVISION WICHITA KANSAS

NAME	DATE	TITLE
DRAWN TENNANT	3/8/60	WIRING DIAGRAM - CIGAR LIGHTER (OPTIONAL)
CHECK COOK	3/8/60	
PROJ SATLER	3/10/60	

Cessna.

DWG NO: 0410011

REV: E PAGE: 13/1

ITEM NO	PART NO.	DESCRIPTION	INSTALLED ON
4	60232-1	CIRCUIT BREAKER (CUE)	
3	0513039-5	WIRE ASSY.	
2	0513052-3	LIGHTER ASSY.	
1	5-1091-10	FUSE	

EQUIPMENT TABLE

SUPERSEDED BY	SUPERSEDES	MODEL
R 13.1.1		150

REVISION			
LET	DESCRIPTION	DATE	APPD
A	BY REV: ADD HC2 & HC3, DA9(REF) WAS DAB(REF)(NOW SHOP PRACTICE)(MER150E0029)	DEF 4-10-74	<i>JRS</i>

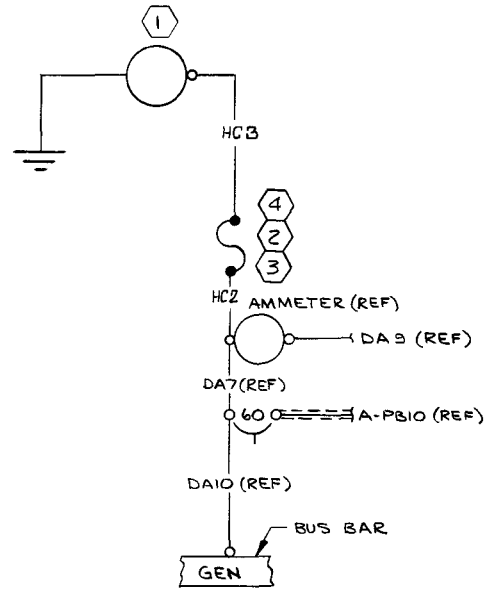

WIRE CODE NO.	GA	MATERIAL	LG	TERMINALS	SERIALS
HC 3	16	SOLDER	1367-2-8		
HC 2	16	SOLDER	1367-2-10		

WIRE TABLE

PART NO.	DESCRIPTION
4 0513052-21	FUSE ASSY
3 155109A	FUSEHOLDER
2 SFE 9	FUSE
1 0513052	LIGHTER ASSY

EQUIPMENT TABLE

CES-1000 IS APPLICABLE
VENDOR CODES PER S-1400
CES-XXXX*CESSNA SPEC. NO.
S-XXX OR CMXXXX*CESSNA
STD. NO.

SUPERSEDES:
Pg. 13.1

SUPERSEDED BY:

CONTRACT NO.		
DESIGN	NAME	DATE
GROUP	<i>R. W. Wood</i>	10-17-73
DRAWN	MERRICK	10-11-73
CHECK	PAPE	10-11-73
STRESS	R.W. SHEFFLER	10-19-73
PROJ	<i>R. W. Wood</i>	10-19-73
APPD		
OTHER		

COMMERCIAL AIRCRAFT DIV.
5800 E. PAWNEE
WICHITA, KANSAS

Cessna. AIRCRAFT CO.

TITLE
**WIRING DIAGRAM —
CIGAR LIGHTER
(OPTIONAL)**

SIZE: C
CODE IDENT. NO.: 71379
DWG NO.: 0410011

SCALE: NONE
50, F150, A150, FA150
PAGE: 13.1.1
(SR7650)

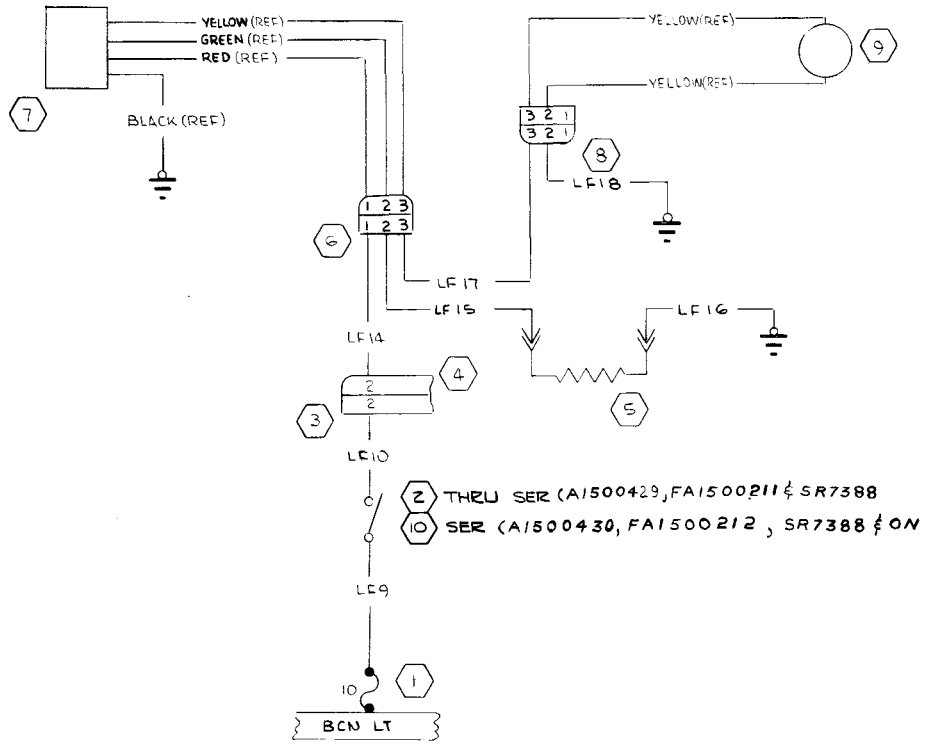

REVISION			
LET	DESCRIPTION	DATE	APPD
A	BY REV: ADD S-2160-1 SER; SER OUT S-1824-1, (621001-0106 WAS 621001-0103 (SR7301) (SR7302) (SR7303) II	DLP 1-10-73	BY N/W RF
B	BY REV: ADD WIRE LENGTHS (NOW SHOP PRACTICE)	SLO 5-4-73	BY S/W RF
C	BY REV: ADD WIRE LENGTH TO LF14 (NOW SHOP PRACTICE)	TDN 1-8-74	BY S/W RF

INACTIVE
EFF THRU SER (SR7900) (SR7901) (SR7902)
8-15-74 BRF (15077000, A1500G14)
JAY
SLO
M/W
RF

500-090-222-00

ITEM NO	PART NO.	DESCRIPTION
10	S-2160-1	SWITCH
9	621001-0106	LIGHT ASSY
8	S-1638-2	HOUSING-CAP
7	6594502-0101	FLASHER ASSY
6	S-1638-1	HOUSING-PLUG
5	OR95-15	RESISTOR (83777)
4	S-1640-9	HOUSING-DIN
3	S-1641-9	HOUSING-SOCKET
2	S-1824-1	SWITCH
1	S-1091-10	FUSE

EQUIPMENT TABLE	
CES-1000 IS APPLICABLE VENDOR CODES PER S-1400 CES-XXXX-CESSNA SPEC. NO. S-XXX OR CMXXXX-CESSNA STD. NO.	SUPERSEDES: P 11.6 SUPERSEDED BY: 0470401 P 11.5

WIRE CODE NO	GA	MATERIAL	LG	TERMINALS	SERIALS
LF18	16		5	S-1635-2	S-1367-2-8
LF17	16		75	S-1635-2	S-1636-2
LF16	16		6	S-1493-2	S-1367-2-8
LF15	16		5	S-1493-2	S-1636-2
LF14	16		290	S-1635-2	S-1636-2 (STD)
LF10	16		6	S-1493-2	S-1636-2
LF9	16		5	SOLDER	S-1493-2

CONTRACT NO:			WIRE TABLE	
DESIGN	NAME	DATE	TITLE	
GROUP	COOK	6-16-72	Cessna AIRCRAFT CO.	
DRAWN	H.W. WOOD	6-22-72	COMMERCIAL AIRCRAFT DIV. 5800 E. PAWNEE WICHITA, KANSAS	
CHECK	WHITE	6-19-72	WIRING DIAGRAM - LIGHT-FLASHING BEACON (OPTIONAL)	
STRESS	PRATT	27 JUN 72	SIZE	NO. IDENT.
PROJ	RF	7-5-72	C	71379
APPD			DWG NO	0410011
OTHER			SCALE: NONE	150
			PAGE: 11.6, 1	

(S121000) (SR7001) (SR7162)
(15073662; F15000864; A1500340; F15000167) & A

Change 3 20-29

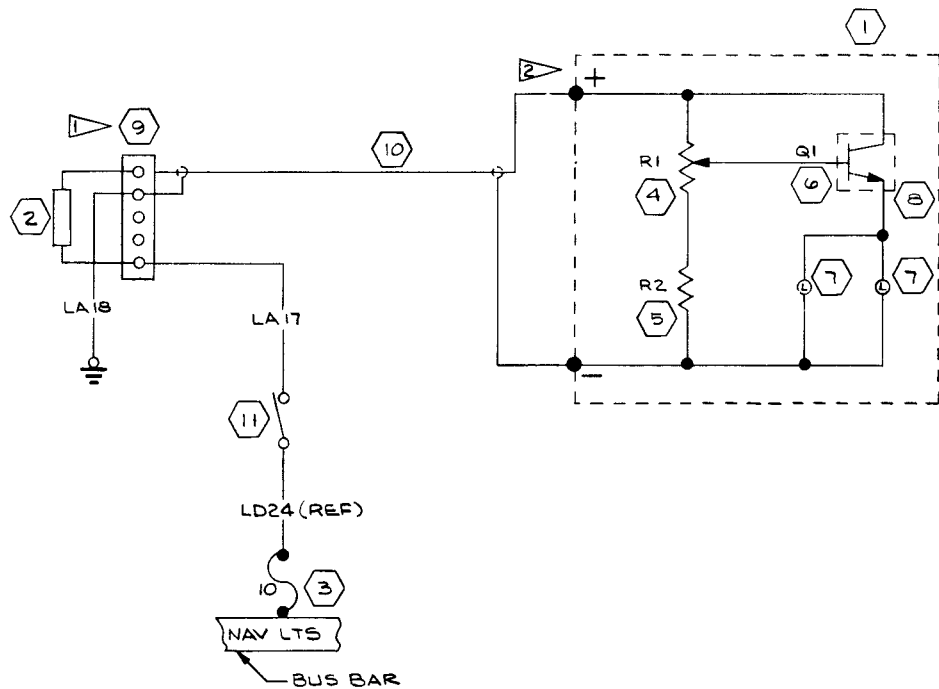

REVISION			
LET	DESCRIPTION	DATE	APPD
A	BY REV: LD24(REF) WAS LD16(REF), 1570141-1 WAS 1570191-1 & S-1824-1 WAS 26-009-100 ED&RR 01990 (SR5437) IX	3-27-68	RLY GKI MDS JFW DWC
B	BY REV: LA-17 WAS LA-15 & LA18 WAS LA-16 ; 329636 WAS NOTE 1/LA-15 & LA-16; INACT DWG	2-25-70	DLP LKW RLY RF

INACTIVE:
 EFF SER 15069309
 THRU SER 15072003
 DLP LKW RLY
 JFW
 ED&RR 10857 2-12-70

NOTES:

- 1. TERMINATE RETRACTILE CABLE AT TERM. BLOCK END WITH 320733 TERM.(00779) ON CENTER CONDUCTOR & WITH 329636 TERM.(00779) ON BRAID SHIELD. SOLDER CABLE TO CIRCUIT BOARD AS SHOWN.
- 2. WARNING: FAILURE TO OBSERVE POLARITY SHOWN ON THIS DIAGRAM WILL RESULT IN IMMEDIATE FAILURE OF 2N2270 TRANSISTOR (49671) ON THE CIRCUIT BOARD ASSY

ITEM NO.	PART NO.	DESCRIPTION	VENDOR
11	S-1824-1	SWITCH	(10389)
10	8499	RETRACTILE CORD	(70903)
9	S-171	TERMINAL BD	(71785)
8	NF-205	HEAT SINK	(05820)
7	2160D	LAMP	(24446)
6	2N2270	TRANSISTOR	(49671)
5	3.0 1/2 W 5%	RESISTOR	
4	5H644Z	POTENTIOMETER	(71450)
3	S-1091-10	FUSE	
2	1570141-1	FUSE ASSY	
1	1570142-3	MAP LIGHT ASSY	

EQUIPMENT TABLE		
PART NO.	DESCRIPTION	VENDOR
CES-1000 IS APPLICABLE VENDOR CODES PER S-1400 CES-XXXX=CESSNA SPEC. NO. S-XXX OR CMXXXX=CESSNA STD. NO.		
SUPERSEDES:		
SUPERSEDED BY:		

WIRE CODE NO.	GA	MATERIAL	LG	TERMINALS	SERIALS
LA 18	18		5-1367-1-6	329636	
LA 17	18		5-1367-1-6	329636	

CONTRACT NO:			WIRE TABLE		
DESIGN	NAME	DATE	Cessna AIRCRAFT CO.		
GROUP	H. Wad	11-27-67	COMMERCIAL AIRCRAFT DIV. 5800 E. PAWNEE WICHITA, KANSAS		
DRAWN	HARRIS	11-20-67	TITLE		
CHECK	LAURIE	11-21-67	WIRING DIAGRAM - MAP LIGHT CONTROL WHEEL (OPT)		
STRESS	WETHINGRIV	11-27-67	SIZE	CODE IDENT. NO.	DWG NO.
PROJECT	CG-K-222	11-27-67	C	71379	0410011
APPD	J S MARTEM	11-27-67	SCALE: NONE	150	PAGE: 11,70

REVISION			
LET	DESCRIPTION	DATE	APPD
A	BY REV: SER OUT S-1824-1 & SER IN S-2160-1 (SR7301)(SR7302)(SR7388) IX	LES 11-17-72	RF H/W
B	BY REV: ADD WIRE LENGTHS, 20GA WAS 18GA PER LA17 & LA18 (NOW SHOP PRACTICE)	JLO 3-16-73	RF H/W
C	BY REV: S-1367-1-8 WAS S-1493-1/LA18 (NOW SHOP PRACTICE) (MER150E0023)	JEF 4-10-74	JLO RF H/W

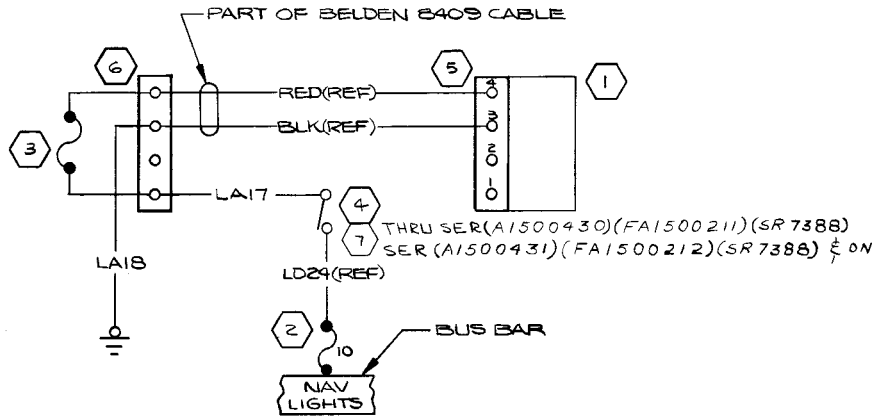

INACTIVE
EFF THRU SER(SR7900)(SR7901)(SR7902)
8-15-74 BRF(15077000, A1500619)
JEF
RF
H/W

00-223-0905

WIRE CODE NO.	GA	MATERIAL	LG	TERMINALS	VENDOR	SERIALS
LA18	20		16	S-1367-1-8	325636 (00779)	
LA17	20		12	S-1493-1	325636 (00779)	

ITEM NO.	PART NO.	DESCRIPTION	QUANTITY
7	S-2160-1	SWITCH	
6	S-171	TERM. BLOCK (71785)	
5	520-4	TERM. BLOCK (75382)	
4	S-1824-1	SWITCH	
3	1570141-1	FUSE ASSY	
2	S-1091-1	FUSE	
1	0570088-1	MAPLIGHT ASSY	

EQUIPMENT TABLE

CES-1000 IS APPLICABLE
VENDOR CODES PER S-1400
CES-XXXX-CESSNA SPEC. NO.
S-XXX OR CMXXXX-CESSNA
STD. NO.

SUPERSEDES:
P 11.7.0

SUPERSEDED BY:
0470401 P 11.6

WIRE TABLE

CONTRACT NO: _____

NAME: _____ DATE: _____

DESIGN: JHENSRAW 7-27-70

GROUP: H. White 2-27-70

DRAWN: PAPE 2-12-70

CHECK: K.K. WHITE 2-25-70

STRESS: _____

PROJ: P. J. 2-27-70

APPD: R. YOUNGERS 2-27-70

OTHER: _____

COMMERCIAL AIRCRAFT DIV.
5800 E. PAWNEE
WICHITA, KANSAS

Cessna AIRCRAFT CO.

TITLE: **WIRING DIAGRAM —
MAPLIGHT-CONTROL WHEEL**

SIZE: C

CODE IDENT. NO.: 71379

DWG NO: 0410011

SCALE: NONE 150

PAGE: 11.7.1

Change 3 20-31

REVISION			
LET	DESCRIPTION	DATE	APPD
A	BY REV: 18GA WAS ZOGA/LD28 & LD29 ED & R.R. 10087	6-23-70	LKW H/W RF
B	BY REV: S-1091-10 WAS S-1360-10, C622004-0103 WAS C622004-0101 ED & R.R. 10149 (NOW SHOP PRACTICE) 10169	8-21-70	LKW H/W RF

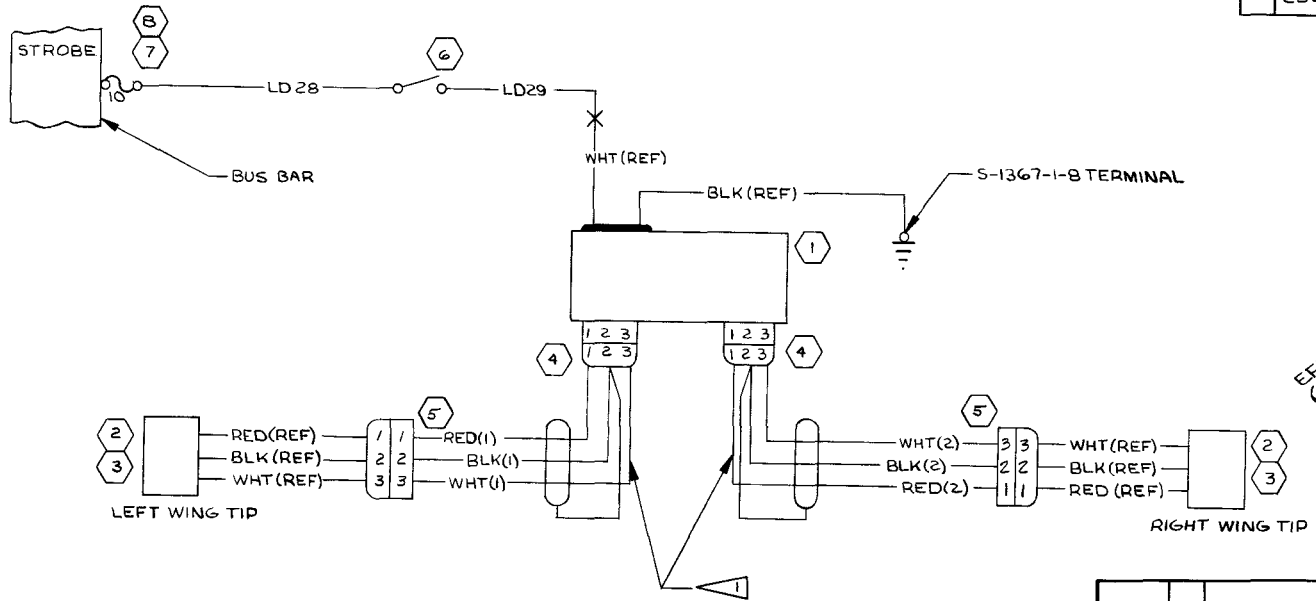

INACTIVE
 EFFECTIVE SER 15072004, A15000227 THRU SER 15073658 (A1500342) (FA150016)
 WIRE H/W DATE RF 6-16-72

NOTES:
 1 ▽ THREE CONDUCTOR CABLE, BELDEN(70903) PART NO. 8770 OR EQUIVILANT TO BE USED

ITEM NO.	PART NO.	DESCRIPTION
8	S-1090-3	FUSEHOLDER
7	S-1091-10	FUSE
6	S-1824-1	SWITCH
5	S-1638-1	HOUSING
4	S-1638-2	HOUSING
3	C622003-0102	LENS
2	C622003-0101	LIGHT UNIT
1	C622004-0103	POWER SUPPLY

EQUIPMENT TABLE	
CES-1000 IS APPLICABLE VENDOR CODES PER S-1400 CES-XXXX-CESSNA SPEC. NO. S-XXX OR CMXXXX-CESSNA STD. NO.	SUPERSEDES: SUPERSEDED BY: P 11.8.1

WIRE CODE NO.	GA	MATERIAL	LG	TERMINALS	SERIALS
WHT(2)	18			5-1635-2	5-1636-2
BLK(2)	18				
RED(2)	18				
WHT(1)	18				
BLK(1)	18				
RED(1)	18			5-1635-1	5-1636-2
LD29	18			S-1370-1	S-1493-1
LD28	18			S-1367-18	S-1493-1

CONTRACT NO:			COMMERCIAL AIRCRAFT DIV. 5800 E. PAWNEE WICHITA, KANSAS	
DESIGN	HENSHAW	10-27-69	TITLE	
GROUP	H. W. H.	10-27-69	WIRING DIAGRAM - WING TIP STROBE LIGHT (OPTIONAL)	
DRAWN	J. D. RAINES	10/22/69	SIZE	CODE IDENT. NO.
CHECK	HARRIS	10-23-69	C	71379
STRESS			DWG NO.	0410011
PROJ	G. J. F.	10-30-69	SCALE: NONE	150
APPD	M. J. W.	10/23/69	PAGE:	11.8
OTHER				

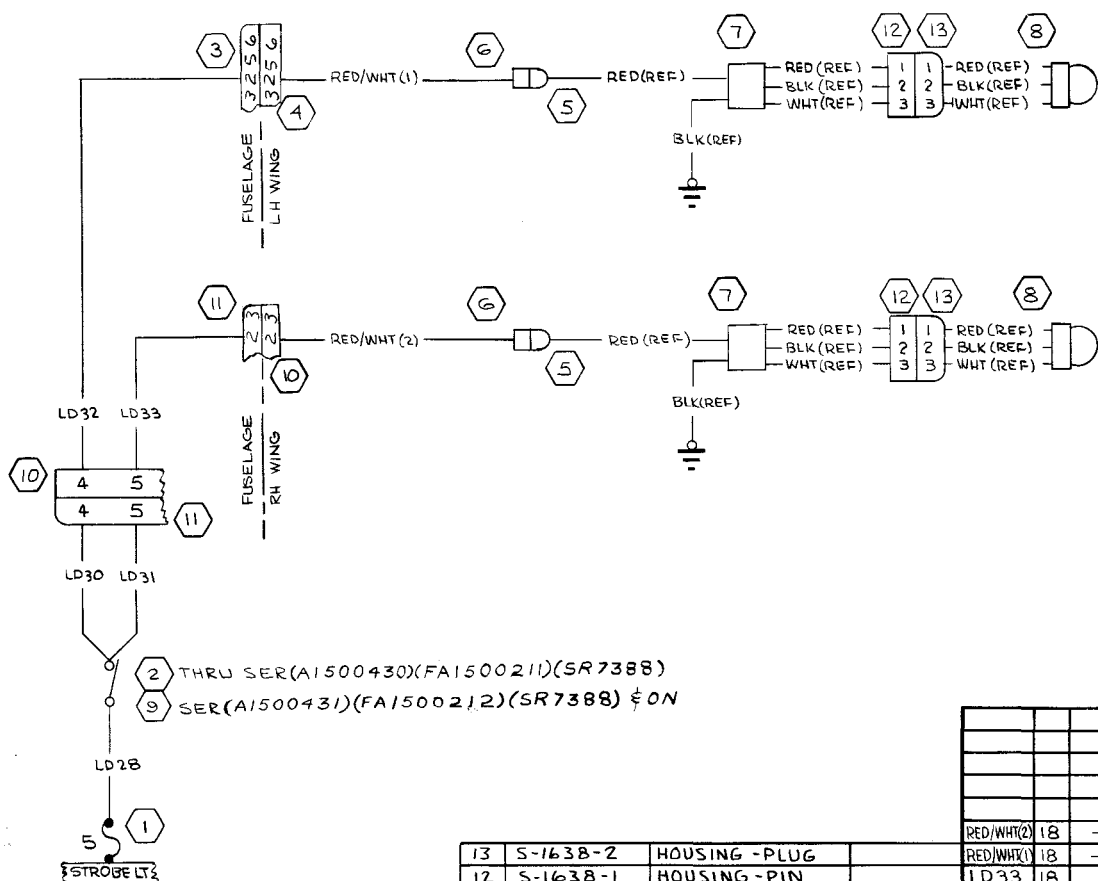

REVISION			
LET	DESCRIPTION	DATE	APPD
A	BY REV: SER OUT S-1824-1 & SER IN S-2160-1 (SR7301) (SR7302) (SR7388) II	LES 11-17-72	RF
B	BY REV: ADD WIRE LENGTHS (NOW SHOP PRACTICE)	DLO 3-15-73	RF
C	BY REV: S-1640-9 & S-1641-9 WERE S-1637-1 & S-1637-2 / RH WING ROOT, S-1640-6 & S-1641-6 WERE S-1637-1 & S-1637-2 / LH WING ROOT, S-1635-2 WAS S-1636-2 / LD30, LD31 & RED/WHT (1) & (2), S-1636-1 WAS S-1635-2 / LD32, LD33 & RED/WHT (1) & (2), S-1493-1 WAS S-1493-2 / LD28, ADD S-1638-1 & S-1638-2 (NOW SHOP PRACTICE) (MER 150 EDO29)	TDN 4-10-74 JEF	RF

INACTIVE
EFF THRU SER(SR7900)(SR7901)(SR7902)
8-18-74
REF (15077000, A1500614)
RF

THRU SER(A1500430)(FA1500211)(SR7388)
SER(A1500431)(FA1500212)(SR7388) & ON

ITEM NO.	PART NO.	DESCRIPTION
13	S-1638-2	HOUSING - PLUG
12	S-1638-1	HOUSING - PIN
11	S-1641-9	HOUSING - PLUG
10	S-1640-9	HOUSING - PIN
9	S-2160-1	SWITCH
8	C622006-0101	LAMP ASSY
7	C622007-0101	POWER SUPPLY
6	S-1637-2	HOUSING - PLUG
5	S-1637-1	HOUSING - PLUG
4	S-1640-6	HOUSING - PIN
3	S-1641-6	HOUSING - SOCKET
2	S-1824-1	SWITCH
1	S-1091-5	FUSE

EQUIPMENT TABLE	
ITEM NO.	DESCRIPTION
1	STROBE LIT

CES-1000 IS APPLICABLE
VENDOR CODES PER S-1400
CES-XXXX-CESSNA SPEC. NO.
S-XXX OR CMXXXX-CESSNA
STD. NO.

SUPERSEDES:
P 11.8
SUPERSEDED BY:
0470401 P 11.7

WIRE CODE NO.	GA	MATERIAL	LG	TERMINALS	SERIALS
RED/WHT(2)	18	-18-2-9	216	S-1636-1	S-1636-1 (STD)
RED/WHT(1)	18	-18-2-9	216	S-1636-1	S-1636-1 (STD)
LD33	18		60	S-1635-1	S-1636-1 (STD)
LD32	18		60	S-1635-1	S-1636-1 (STD)
LD31	18		10	SEE LD30	S-1635-2
LD30	18		10	S-1493-2	S-1635-2
LD28	18		5	SOLDER	S-1493-1

CONTRACT NO.			WIRE TABLE	
DESIGN	NAME	DATE	GROUP	DATE
COOK	H. Wad	6-16-72	COOK	6-22-72
DRAWN	WHITE	6-16-72	CHECK	6-19-72
STRESS	PATE	27 Jun 72	PROJ	7-2-72
APPD			APPD	
OTHER			OTHER	

COMMERCIAL AIRCRAFT DIV.
5800 E. PAWNEE
WICHITA, KANSAS

Cessna AIRCRAFT CO.

TITLE
**WIRING DIAGRAM -
WING TIP STROBE LIGHT
(OPTIONAL)**

SIZE
C

CODE IDENT. NO.
71379

DWG NO.
0410011

SCALE: NONE

PAGE: 11.8.1

(SR7000) (SR7001) (SR7162)
(15073662; A15000431; F15000864; FA15000167)

Change 3 20-33

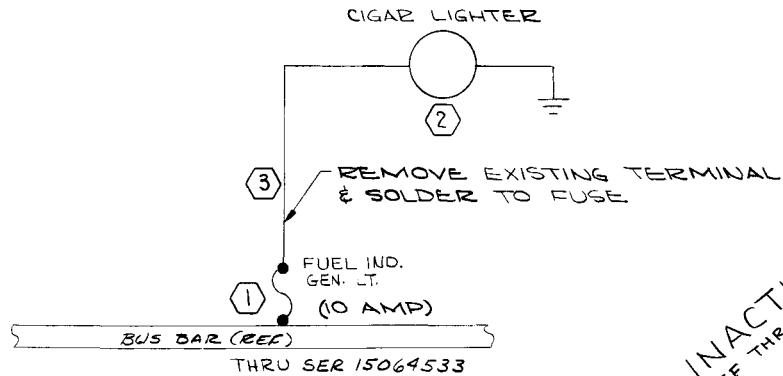
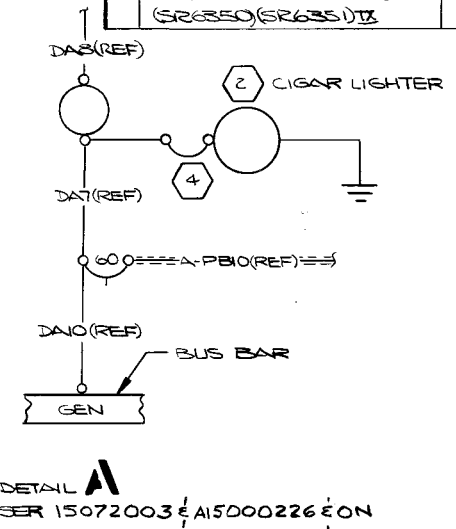
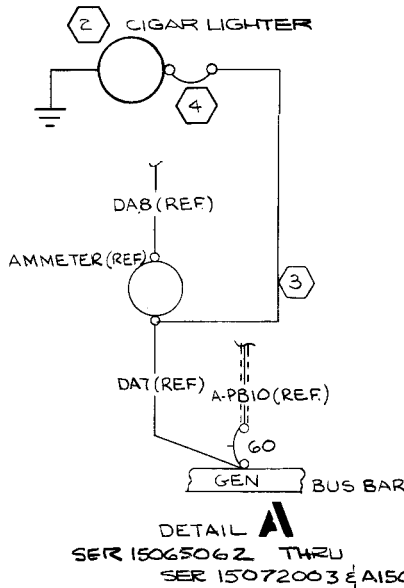
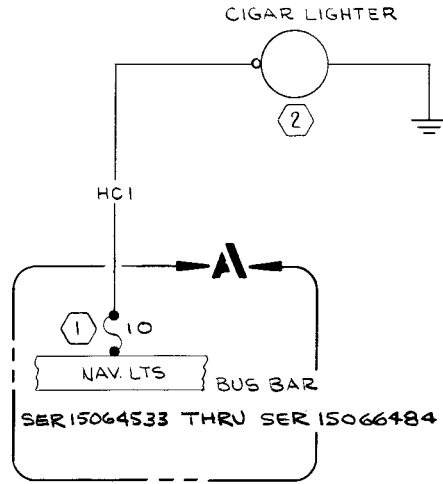

INACTIVE;
 EFF THRU SER (S27690X) (150725564, F15001143, 10/11-73 A1500480 & FA1500226)
 RAM
 3/10
 HZW
 RRF

CHG LET	REVISION	BY	CHK
B	REDRAWN NO CHG	3/82-62	RFW
C	ADDED E/T; ADDED HCl TO W/T & ADDED LIMITING SERIALS; FUEL IND. GEN LT WAS DOME LT FUSE; (15064533)	9/78 10-8-65	RFW RFW
D	BY REV: ADD 60232-1 TO E/T; ADD DETAIL A TO FLD; IN W/T HCl SERIALIZED OUT; 0513052-3 WAS 0513039-7 IN E/T (SR 5153)	9/78 7-20-66	YAK RFW
E	BY REV: SER OUT DETAIL "A"; ADD DETAIL "A" & SER EDRE 10021 (SR635) (SR635) IS	4-29-70	DLP RFW RF

WIRE CODE NO.	GA	MATERIAL	LG	TERMINALS	SERIALS
HCl	16	SOLDER	3-13672-8	(15064533) THRU (SR5153)	

CESSNA AIRCRAFT CO., COMMERCIAL AIRCRAFT DIVISION, WICHITA, KANSAS					
NAME	DATE	TITLE			
DRAWN TENNANT	3/8/60	WIRING DIAGRAM - CIGAR LIGHTER (OPTIONAL)			
GROUP					
CHECK COOK	3/8/60		DWG NO: 0410011		
PROJ SATTLER	3/10/60		REV: E PAGE: 13/1		
SUPERSEDED BY P. 13.1.1	SUPERSEDES	MODEL: 150	FORM NO. 80-161		

ITEM NO	PART NO.	DESCRIPTION	INSTALLED ON
4	60232-1	CIRCUIT BREAKER (CUE)	
3	0513039-5	WIRE ASSY.	
2	0513052-3	LIGHTER ASSY.	
1	5-1091-10	FUSE	

EQUIPMENT TABLE

REVISION			
LET	DESCRIPTION	DATE	APPD
A	BY REV: ADD HC2 & HC3, DA9(REF) WAS DAB(REF)(NOW SHOP PRACTICE)(SER 150E0023)	JEF 4-10-74	<i>JEF</i>

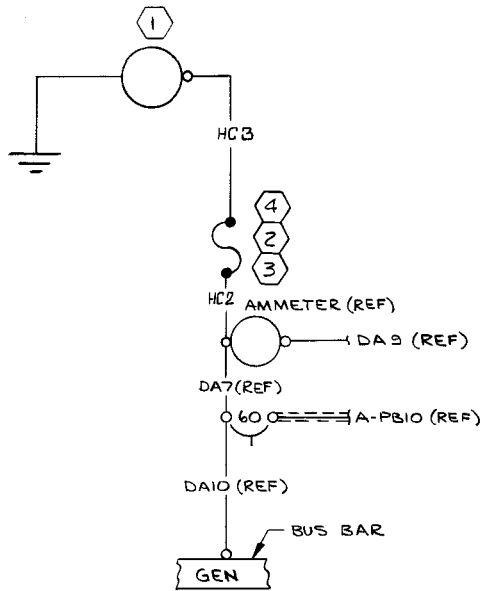

INACTIVE
EFF THRU SER(SR7900)(SR7901)(SR7902)
8-15-74
BRF(15077000, A1500619)
*Doc
for
MIL
REF*

00-223-0905

WIRE CODE NO	GA	MATERIAL	LG	TERMINALS	SERIALS
HC 3	16			SOLDER 1367-2-8	
HC 2	16			1367-2-40 SOLDER	

WIRE TABLE

ITEM NO.	PART NO.	DESCRIPTION
4	0513052-21	FUSE ASSY
3	155109A	FUSEHOLDER
2	SFE 9	FUSE
1	0513052	LIGHTER ASSY

EQUIPMENT TABLE

CES-1000 IS APPLICABLE
VENDOR CODES PER S-1400
CES-XXXX-CESSNA SPEC. NO.
S-XXX OR CMXXXX-CESSNA
STD. NO.

SUPERSEDES:
Pg. 13.1

SUPERSEDED BY:
0470401 P 13.1

CONTRACT NO:		NAME	DATE
DESIGN			
GROUP	H. W. W.	10-17-73	
DRAWN	MERRICK	10-11-73	
CHECK	PAPE	10-11-73	
STRESS	R.W. SHEFFLER	10-19-73	
PROJ	R. J. Fife	10-19-73	
APPD			
OTHER			

COMMERCIAL AIRCRAFT DIV.
5800 E. PAWNEE
WICHITA, KANSAS

Cessna. AIRCRAFT CO.

TITLE
**WIRING DIAGRAM -
CIGAR LIGHTER
(OPTIONAL)**

SIZE: C
CODE IDENT. NO.: 71379
DWG NO.: 0410011

SCALE: NONE
150F150, A150, FA150
PAGE: 13.1.1

Change 3 20-35

(SR4920)

CHG LET	REVISION	BY DATE	CHK APPD
A	BY REV: S-1640-9, S-1641-9, FB 10, FB 11 & FB 12, S-1091-15 S-1824-1 & DETAIL A & SER; SER OUT FB 8 & FB 9 ED & RR 00242 (SR3437) II	JWH 12-6-64	RLI HJW DK
B	BY REV: SER OUT BLK & BLU; SER IN BLU (1) & BLK (1); ADD DETAIL 'B' & SER (SR7320)	JCY 11-6-72	EW HJW RF
C	BY REV: ADD WIRE LENGTHS (NOW SHOP PRACTICE)	JLO 5-4-73	RF HJW RF
D	BY REV: ADD "STD"/BLU 1 & FB 12 (NOW SHOP PRACTICE)	TDN 1-9-74	RF HJW RF
E	BY REV: ADD ITEM 12 (NOW SHOP PRACTICE)	MEM 4-25-74	RF HJW RF
F	BY REV: ADD S-2160-1 (NOW SHOP PRACTICE) (SR 7300)(REF)(SR 7301)(REF) (SR 7302)(REF)	BRF 6-11-74	JLO RF RF

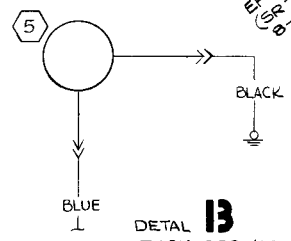
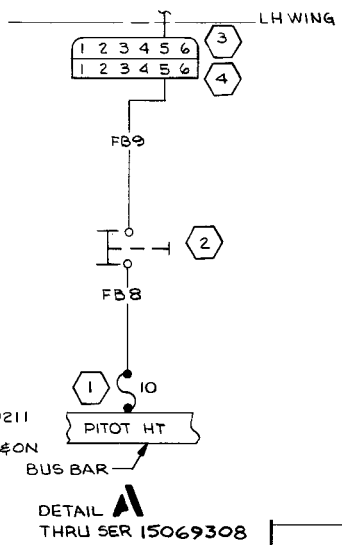
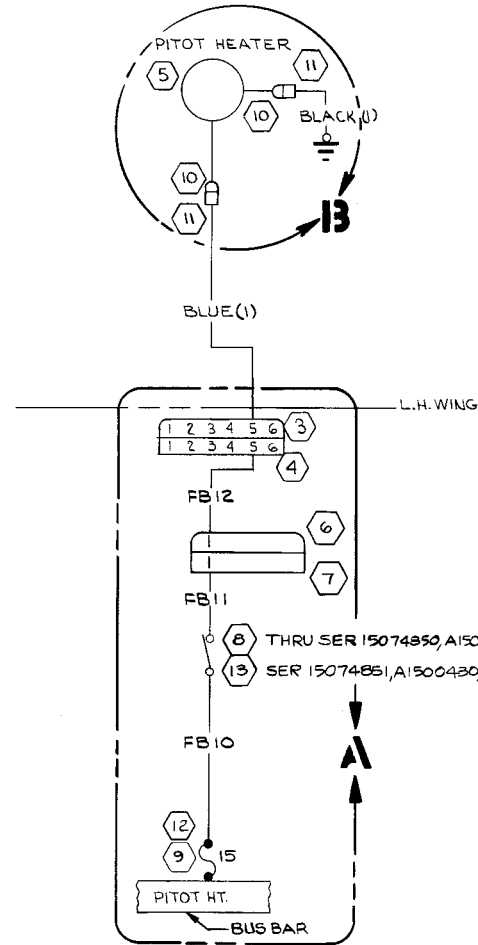

INACTIVE
EFF THRU SER (SR 7300)
(SR 7301) (SR 7302) (S-15077000,
S-15-74 BRF
A1500614)

DETAIL B
THRU SER (SR 7320) 15074466,
A1500395, F15000929 & FA1500189

ITEM NO	PART NO.	DESCRIPTION	INSTALLED ON
13	S-2160-1	SWITCH	
12	S-1090-4	FUSE HOLDER	
11	S-1637-2	HOUSING-PLUG	
10	S-1637-1	HOUSING-CAP	
9	S-1091-15	FUSE	
8	S-1824-1	SWITCH	
7	S-1641-9	HOUSING-SOCKET	
6	S-1640-9	HOUSING-PIN	
5	0721105-5	PITOT HEATER	
4	S-1641-6	HOUSING-SOCKET	
3	S-1640-6	HOUSING-PIN	
2	0713026-4	SWITCH ASSY.	
1	S-1091-10	FUSE	

WIRE CODE NO.	GA	MATERIAL	LG	TERMINALS	SERIALS
BLU (1)	16	S-1460-16-6	55	S-1635-2 S-1636-2	STD SER (SR 7320) 4 ON
BLK (1)	18	S-1460-18-0	10	S-1636-2 S-1637-8	SER (SR 7320) 4 ON
FB 12	16		53	S-1635-2 S-1636-2	STD
FB 11	16		6	S-1493-2 S-1636-2	
FB 10	16		6	SOLDER S-1493-2	
BLUE	16	S-1460-16-6		S-1635-2 S-1636-2	STD. THRU SER (SR 7320)
FB 9	16			S-1367-2-8 S-1636-2	STD. THRU SER (SR 5437)
FB 8	16			SOLDER S-1367-2-8	0422354 THRU SER (SR 5437)
BLACK	18	S-1460-18-0		S-1367-1 S-1367-1-8	0422354 THRU SER (SR 7320)

WIRE TABLE

CESSNA AIRCRAFT CO., COMMERCIAL AIRCRAFT DIVISION, WICHITA, KANSAS

DRAWN	NAME	DATE	TITLE
BLISS		10-8-65	WIRING DIAGRAM—
GROUP	H. Wied	10-29-65	PITOT HEAT
CHECK	E. Stuck	10-30-65	(OPTIONAL)
PROJ	J. Smith	11-2-65	

DWS NO: 0410011

REV: E PAGE: 13.3

SUPERSEDED BY: 0410011 P 13.2 SUPERSEDES: 0410011 P 6.13.2.1 MODEL: 150

500-000-00

NOTES:

SWITCH SHOWN IS AN "ON-ON" MOMENTARY "ON" SWITCH CONFIGURATION SUCH THAT THE MOTOR IS SHORTED OUT IN THE CENTER ("ON") POSITION. SWITCH IS SHOWN IN CENTER ("ON") POSITION.

REVISION			
LET	DESCRIPTION	DATE	APPD
A	BY REV: ADD CC25, CC26, S-1640-9, S-1641-9 & DETAIL ASSY SER; SER OUT CC16. ED & RR 00948 (SR 5474) II	JWH 12-6-67	RLC NEW PKC
B	BY REV: REVERSE ITEMS 9 & 10 IN FIELD; ADD PIN 6 TO ITEMS 9 & 10; S-1635-2/CC26 WAS S-1635-2/CC25 & S-1636-2/CC25 WAS S-1636-2/CC26	RLY 3-27-68	GKI MDS F-11-67 D&K

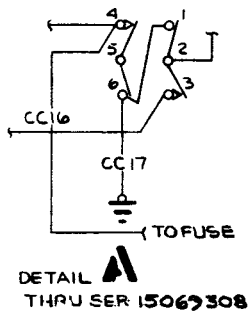
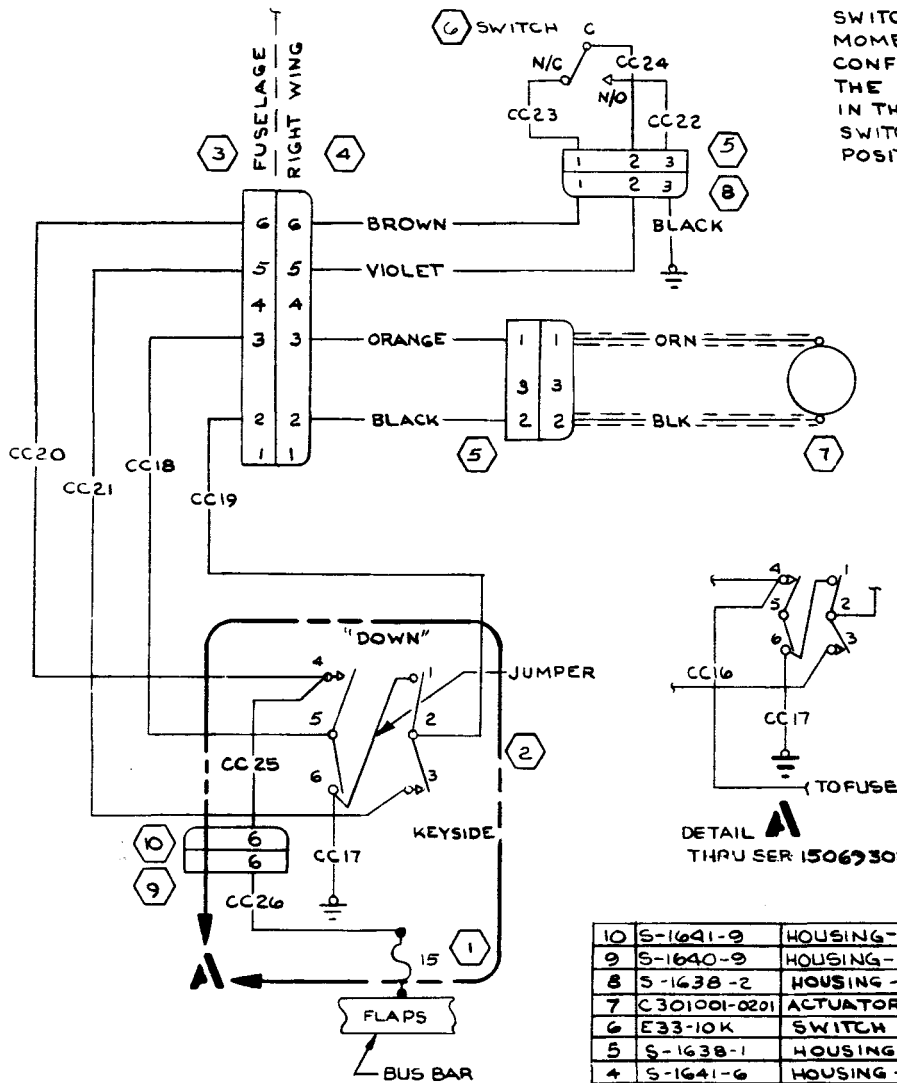

INACTIVE
EFF THRU SER (SR 6584)
WRC
1/10

CC26	16		SOLDER	S-1635-2		
CC25	16		S-1636-2	S-1367-2-6		
CC24	16		S-1636-2	S-1367-1-4		
CC23	16		S-1636-2	S-1367-1-4		
CC22	18		S-1636-2	S-1367-1-4		
BLACK	16	-16-0	S-1636-2	S-1493-2		
ORANGE	16	-16-3	S-1636-2	S-1493-2		
BLACK	18	-18-0	S-1635-2	S-1367-1-9		
BROWN	16	-16-1	S-1635-2	S-1635-2		
VIOLET	16	-16-7	S-1635-2	S-1635-2		
BLACK	16	-16-0	S-1635-2	S-1636-2		
ORANGE	16	-16-3	S-1635-2	S-1636-2		
CC21	16		S-1367-2-6	S-1636-2		
CC20	16		S-1367-2-6	S-1636-2		
CC19	16		S-1367-2-6	S-1636-2		
CC18	16		S-1367-2-6	S-1636-2		
CC17	18		S-1367-1-6	S-1367-1-3		
CC16	16		SOLDER	S-1367-2-6 (5067199)	THRU SER (SR 5474)	

ITEM NO.	PART NO.	DESCRIPTION	VENDOR
10	S-1641-9	HOUSING-SOCKET	
9	S-1640-9	HOUSING-PIN	
8	S-1638-2	HOUSING-SOCKET	
7	C301001-0201	ACTUATOR ASSY	
6	E33-10K	SWITCH (01963)	
5	S-1638-1	HOUSING-PLUG	
4	S-1641-6	HOUSING-SOCKET	
3	S-1640-6	HOUSING-PIN	
2	S-1661-2	SWITCH	
1	S-1627-15	FUSE-SLOW-BLO	

ITEM NO.	PART NO.	DESCRIPTION	VENDOR
EQUIPMENT TABLE			
CES-1000 IS APPLICABLE			
VENDOR CODES PER S-1400			
CES-XXXX=CESSNA SPEC. NO.			
S-XXX OR CMXXXX=CESSNA			
STD. NO.			
SUPERSEDES: 14.2.3			
O410011 PG 14.2.2			
SUPERSEDED BY:			
O410011 PG 14.2.5			

WIRE TABLE			
WIRE CODE NO.	G.A.	MATERIAL	LG
CONTRACT NO:			
DESIGN SIPES VR 8/10/67			
GROUP H. W. Hall 8-11-67			
DRAWN SIPES / R 8/10/67			
CHECK VAES HAW 8-11-67			
STRESS amp 8-11-67			
PROJECT W. Hall 8-11-67			
APPD			

CESSNA AIRCRAFT CO.		
COMMERCIAL AIRCRAFT DIV. 5800 E. PAWNEE WICHITA, KANSAS		
TITLE		
WIRING DIAGRAM -		
WING FLAPS -		
ELECTRIC		
SIZE		
C	CODE IDENT. NO. 71379	DWG NO. O410011
SCALE: NONE		
SR 5145 XI PAGE: 14.2.4		

Change 3
20-37

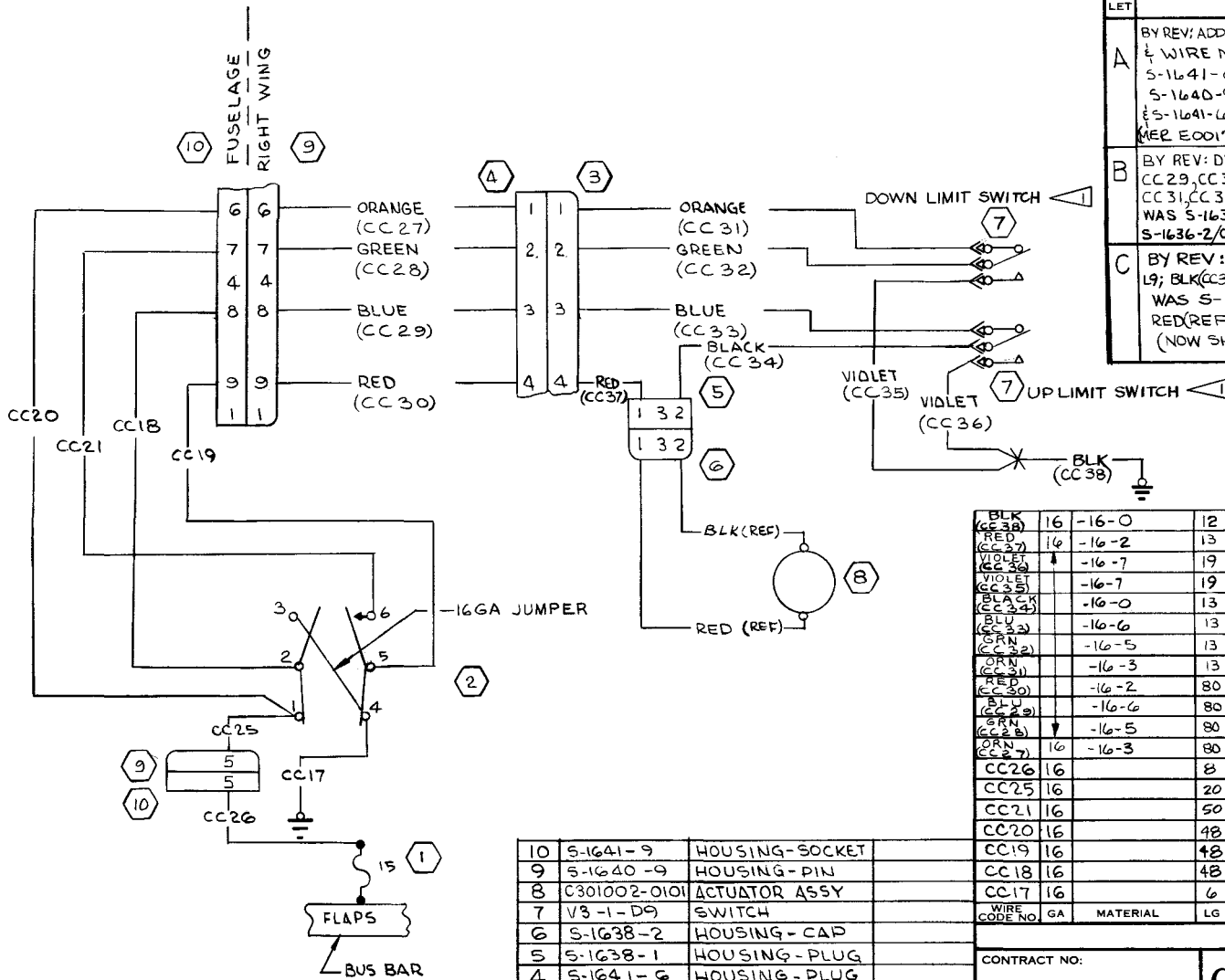

REVISION			
LET	DESCRIPTION	DATE	APPD
A	BY REV: ADD COLOR CODES, WIRE LENGTHS & WIRE MATERIALS, S-1640-6 & S-1641-6 WERE S-1638-1 & S-1638-2, S-1640-9 & S-1641-9 WERE S-1640-6, & S-1641-6/RH WING ROOT (MER E0012) & (NOW SHOP PRACTICE)	BAH 12-12-73 T J P	JAY RF RF
B	BY REV: DELETE (1) FROM CC27, CC28, CC29, CC30 & CC35; DELETE (2) FROM CC31, CC32, CC33, CC36 & CC37; S-1636-2 WAS S-1635-2/CC26, S-1635-2 WAS S-1636-2/CC25 (NOW SHOP PRACTICE) MER 150-EO142	DEF 4-10-74	JLS RF RF
C	BY REV: LG19/CC36 & CC35 WAS L9; BLK(CC38) WAS BLK; SEE CC38 WAS S-1637-2-B/CC35 & CC36 RED(REF) WAS ORN(REF) (NOW SHOP PRACTICE) MER 150-EO142	BRF 5-15-74	JLS RF RF

INACTIVE
EFF THRU SER(SR700)(SR790)(SR792)
8-15-74 BRF(15077000, A1500614)
JLS
RF
RF

WIRE CODE NO	GA	MATERIAL	LG	TERMINALS	SERIALS
BLK (CC 38)	16	-16-0	12	S-1370-2	S-1637-2-B
RED (CC 27)	16	-16-2	13	S-1635-2	S-1636-2
VIOLET (CC 36)		-16-7	19	S-1493-2	SEE BLK (CC 38)
VIOLET (CC 35)		-16-7	19	S-1493-2	SEE BLK (CC 38)
BLACK (CC 34)		-16-0	13	S-1635-2	S-1493-2
BLU (CC 33)		-16-6	13		
GRN (CC 32)		-16-5	13		
ORN (CC 31)		-16-3	13	S-1635-2	S-1493-2
RED (CC 30)		-16-2	80	S-1636-2	S-1635-2
BLU (CC 29)		-16-6	80		
GRN (CC 28)		-16-5	80		
ORN (CC 27)	16	-16-3	80	S-1636-2	S-1635-2
CC26	16		8	S-1636-2	SOLDER
CC25	16		20	S-1635-2	S-1637-2-6
CC21	16		50	S-1637-2-6	S-1636-2
CC20	16		48		
CC19	16		48		
CC18	16		48		S-1636-2
CC17	16		6	S-1637-2-6	S-1637-2-B

NOTES:
1 THESE SWITCHES PART OF C301002-0101 ACTUATOR ASSY.

ITEM NO	PART NO.	DESCRIPTION
10	S-1641-9	HOUSING-SOCKET
9	S-1640-9	HOUSING-PIN
8	C301002-0101	ACTUATOR ASSY
7	V3-1-D9	SWITCH
6	S-1638-2	HOUSING-CAP
5	S-1638-1	HOUSING-PLUG
4	S-1641-6	HOUSING-PLUG
3	S-1640-6	HOUSING-PIN
2	S-1661-2	SWITCH
1	S-1627-15	FUSE-SLOW-BLO

EQUIPMENT TABLE	
PART NO.	DESCRIPTION
CES-1000 IS APPLICABLE	SUPERSEDES: P 14.2.4
VENDOR CODES PER S-1400	SUPERSEDED BY: 0470401 P. 14.1
CES-XXX+CESSNA SPEC. NO.	
S-XXX OR CMXXX+CESSNA	
STD. NO.	

WIRE TABLE

CONTRACT NO: _____

DESIGN: COOK DATE: 2-1-71

GROUP: H. Wier DATE: 2-2-71

DRAWN: COOK DATE: 2-1-71

CHECK: L.K. WHITE DATE: 2-2-71

STRESS: _____

PROJ: G. J. Life DATE: 2-17-71

APPD: _____

OTHER: _____

COMMERCIAL AIRCRAFT DIV.
5800 E. PAWNEE
WICHITA, KANSAS

Cessna AIRCRAFT CO.

TITLE: **WIRING DIAGRAM - WING FLAPS-ELECTRIC**

SIZE: C CODE IDENT. NO. 71379 DWG NO. 0410011

SCALE: NONE 150-A150 PAGE: 14.2-5

REVISION			
LET	DESCRIPTION	DATE	APPD
A	BY REV: DELETE DA 3; CHG TERMINAL LOCATION ON DA 2; DELETE LIGHTER & WIRE LENGTHS (MER E0339)	9-13-74	<i>[Signature]</i>

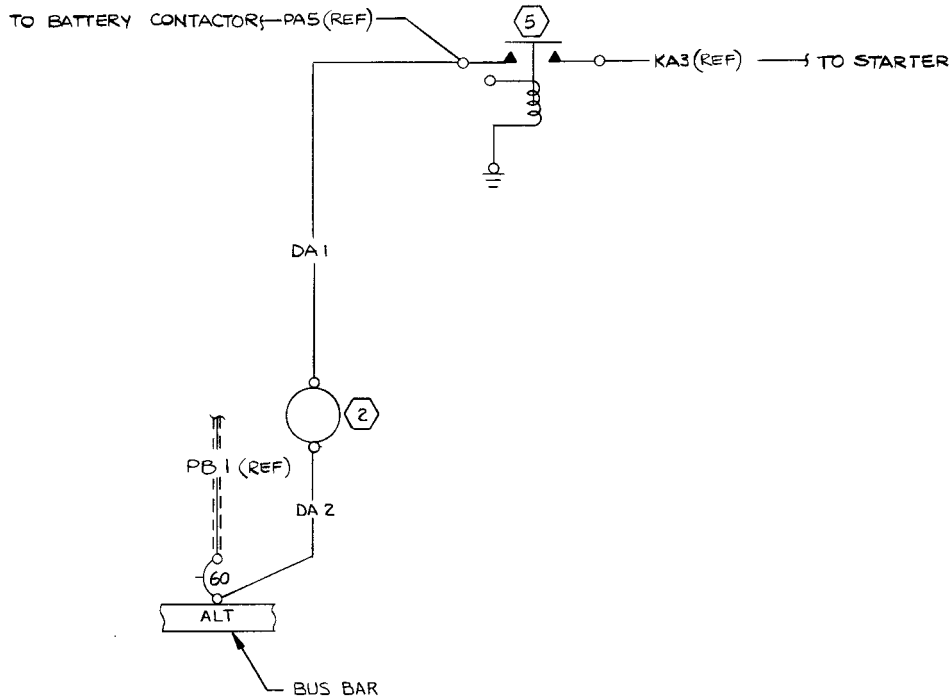

00-223-0905

WIRE CODE NO.	GA	MATERIAL	LG	TERMINALS	SERIALS
DA 2	8			S-1367-4-10	S-1367-4-10
DA 1	8			S-1367-4-10	S-1367-4-10

WIRE TABLE

ITEM NO.	PART NO.	DESCRIPTION
5	S-1991-1	CONTACTOR
2	S-1320-1	AMMETER
1	S-1596-60L	CIRCUIT BREAKER

EQUIPMENT TABLE

CES-1000 IS APPLICABLE
VENDOR CODES PER S-1400
CES-XXXX-CESSNA SPEC. NO.
S-XXX OR CMXXXX-CESSNA
STD. NO.

SUPERSEDES:
0410011 PG 4.8
SUPERSEDED BY:

CONTRACT NO.		COMMERCIAL AIRCRAFT DIV. 5800 E. PAWNEE WICHITA, KANSAS	
DESIGN	J.B. MITCHELL	DATE	8-16-74
GROUP	<i>[Signature]</i>	DATE	8-16-74
DRAWN	B. FROMAN	DATE	8-15-74
CHECK	J. YOWEL	DATE	8-15-74
STRESS		PROJ	<i>[Signature]</i> 8-19-74
OTHER		APPD	
SIZE	C	CODE IDENT. NO.	71379
DWG NO	0470401		
SCALE: NONE	150 A150, FA150	PAGE: 4.1	

(SR7900)(SR7901)(SR7902)

REVISION			
LET	DESCRIPTION	DATE	APPD
A	BY REV: DELETE PB3, PB6, S-1640-9, S-1641-9; S-1635-2/PB5 WAS S-1636-2 DELETE WIRE LENGTHS MER E0339	GS 9-13-74	RF [Signature]

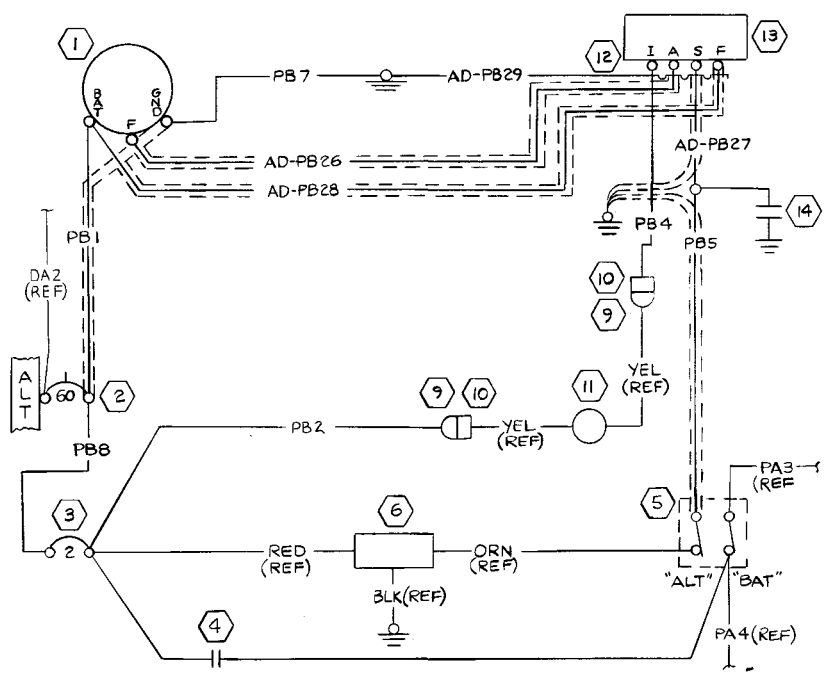

- NOTES:
- 1. TERMINAL 42281-2 (00779) ON CONDUCTOR.
TERMINAL 2-323931-2 (00779) ON SHIELD#GND.WIRE
 - 2. WIRE MATL. PER S-1534-B-9

14	0770038-2	FILTER	
13	C611001-0201	REGULATOR	
12	C6AB-10A730-A	HOUSING	
11	S-2135-1	LIGHT ASSY	
10	S-1637-2	HOUSING-SOCKET	
9	S-1637-1	HOUSING-PIN	
6	C593001-0101	OVERVOLTAGE SENSOR	
5	S-1994-1-1	MASTER SWITCH	
4	TVA-1315	CAPACITOR	
3	CA2	CIRCUIT BREAKER	
2	S-1596-60L	CIRCUIT BREAKER	
1	C611501-0203	ALTERNATOR ASSY	

ITEM NO.	PART NO.	DESCRIPTION
EQUIPMENT TABLE		
CES-1000 IS APPLICABLE VENDOR CODES PER S-1400 CES-XXX-CESSNA SPEC. NO. S-XXX OR CMXXX-CESSNA STD. NO.		
SUPERSEDES: 0410011 PG 4.13.0		SUPERSEDED BY:

PB8	16		S-1367-2-10	S-1367-2-8	
AD-PB29	18		S-1367-1-12		
AD-PB28	18S		S-1367-1-12		
AD-PB27	18S		S-1367-1-6		
AD-PB26	18S		S-1367-1-10		
PB7	8	S-1562-B-9	S-1943-3	S-1367-4-12	
PB5	18S		S-1493-1	S-1367-1-6	
PB4	18		S-1636-2	42281-2	
PB2	16		S-1635-2	S-1367-2-8	
PB1	6S		S-1367-4-10	S-1943-2	
			S-1367-3-10		
WIRE CODE NO.	GA	MATERIAL	LG	TERMINALS	SERIALS

CONTRACT NO:			WIRE TABLE	
DESIGN	J.B. MITCHELL	8-16-74	COMMERCIAL AIRCRAFT DIV. 5800 E. PAWNEE WICHITA, KANSAS	
GROUP	B. FROMAN	8-16-74	Cessna AIRCRAFT CO. TITLE WIRING DIAGRAM — ALTERNATOR SYSTEM, 60 AMP	
DRAWN	J. YOVEL	8-15-74		
CHECK			SIZE	CODE IDENT. NO.
STRESS			C	71379
PROJ			DWG NO	0470401
APPD			SCALE: NONE	150,150A,FA150
OTHER			PAGE: 4.2	

(SR 7900)(SR 7901)(SR 7902)

5060-827-00

REVISION			
LET	DESCRIPTION	DATE	APPD
A	BY REV: REVISED & RELOCATED BKR LOCATION (NOW SHOP PRACTICE) (MERE0339)	MEM GS 9-13-74	<i>[Signature]</i> RF
B	BY REV: S-1360-20L WAS S-1360-15L AT BCN PITOT HT (SR 8260)	BAH 5-13-75	<i>[Signature]</i> RF

(15077006, A1500010, F15001099 & FA1500282)

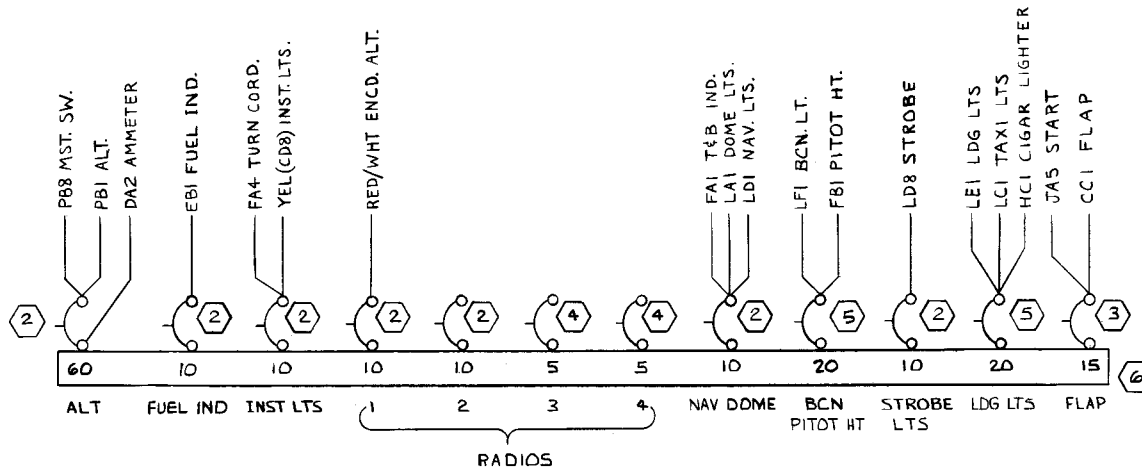

NOTES:

- THIS DWG IS FOR REF INFO ONLY. FOR WIRING & WIRE & TERMINAL REQUIREMENTS SEE APPROPRIATE PAGES OF 0470401.

WIRE CODE NO	GA	MATERIAL	LG	TERMINALS	SERIALS

ITEM NO	PART NO.	DESCRIPTION
6	1270704	BUS BAR
5	S-1360-20L	CKT BKR
4	S-1360-5L	CKT BKR
3	S-1360-15L	CKT BKR
2	S-1360-10L	CKT BKR
1	S-1596-60L	CKT BKR

CES-1000 IS APPLICABLE VENDOR CODES PER S-1400 CES-XXXX-CESNA SPEC. NO. S-XXX OR CMXXXX-CESNA STD. NO.

SUPERSEDES: 0410011 PG 4.14

SUPERSEDED BY:

WIRE TABLE			
CONTRACT NO:		TITLE	
DESIGN	J.B. MITCHELL 8-16-74	Cessna AIRCRAFT CO. COMMERCIAL AIRCRAFT DIV. 5800 E. PAWNEE WICHITA, KANSAS <hr/> WIRING DIAGRAM — BUS BAR, CIRCUIT BREAKER	
GROUP	J. S. ... 8-16-74		
DRAWN	B. FROMAN 8-15-74		
CHECK	J. YOEUL 8-15-74		
PROJ	J.D. ... 8-17-74	SIZE	C
APPD		CODE IDENT. NO.	71379
OTHER		DWG NO	0470401
SCALE: NONE		150, A150, FA150	

(SR7900)(SR7901)(SR7902)

Change 3 20-41

00-823-0905

REVISION			
LET	DESCRIPTION	DATE	APPD
A	BY REV: DELETE WIRE LENGTH (SR7900)(SR7901)(SR7902)	9-13-74	C J H RF

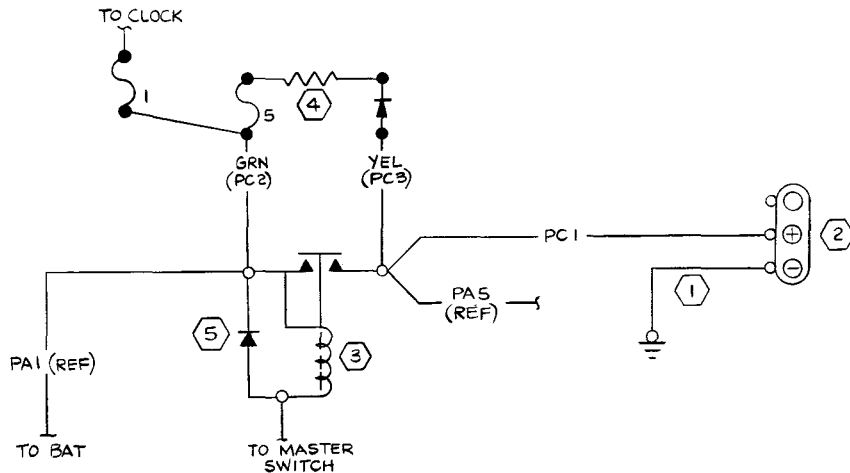

9060-522-00

WIRE CODE NO	GA	MATERIAL	LG	TERMINALS	SERIALS
YEL (PC3)	18	-18-4	5-1367-1-13	SOLDER	
GRN (PC2)	18	-18-5	5-1367-1-13	SOLDER	
PC1	4		5-1367-6-13	5-1367-6-14	

ITEM NO	PART NO.	DESCRIPTION
5	F4	DIODE
4	0712031-3	FUSE & DIODE ASSY
3	S-1579-2	CONTACTOR
2	AN2552-3A	RECEPTACLE
1	0312155-10	GND STRAP

EQUIPMENT TABLE

CES-1000 IS APPLICABLE
VENDOR CODES PER S-1400
CES-XXXX-CESSNA SPEC. NO.
S-XXX OR CMXXXX-CESSNA
STD. NO.

SUPERSEDES:
0410011 PG 4.11

SUPERSEDED BY:

WIRE TABLE

CONTRACT NO:

DESIGN	NAME	DATE
J.B. MITCHELL		8-16-74
B. FROMAN		8-16-74
J. YOUEL		8-15-74
		8-19-74

COMMERCIAL AIRCRAFT DIV.
5800 E. PAWNEE
WICHITA, KANSAS

Cessna AIRCRAFT CO.

TITLE: **WIRING DIAGRAM —
GROUND SERVICE RECEPTACLE
(OPT)**

PROJ: **C** SIZE: **C** CODE IDENT. NO.: **71379** DWG NO.: **0470401**

APPD: **C** OTHER: **C**

SCALE: **NONE** 150, A150, FA150 PAGE: **4.4**

REVISION			
LET	DESCRIPTION	DATE	APPD
A	BY REV: DELETE S-1640-9, S-1641-9, JA3 & JA4; S-1367-1-10 & S-1367-2-6 / JAI & JAZ WERE S-1636-1; DELETE WIRE LENGTHS (MER E0339)	GS 9-13-74	<i>JRM</i> <i>RF</i>

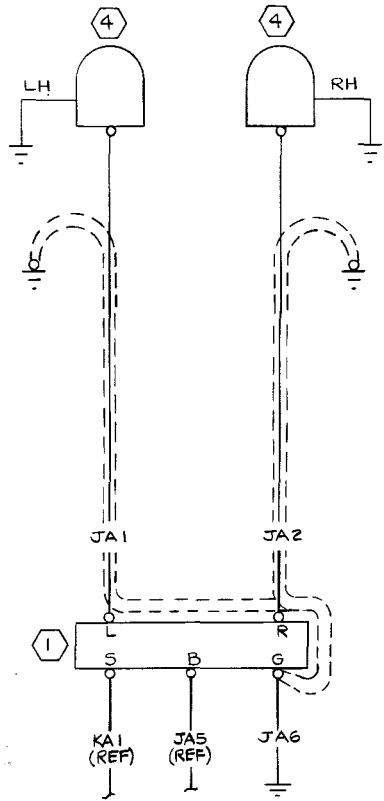

WIRE CODE NO	GA	MATERIAL	LG	TERMINALS	SERIALS
JAG	18			S-1367-1-6 S-1367-1-8	
JAZ	18S			S-1367-1-10 S-1367-1-10 S-1367-2-6 S-1367-2-6	
JAI	18S			S-1367-1-10 S-1367-1-10 S-1367-2-6 S-1367-2-6	

ITEM NO	PART NO.	DESCRIPTION
4	447	MAGNETO
1	C292501-0101	IGNITION SWITCH

EQUIPMENT TABLE

CES-1000 IS APPLICABLE
VENDOR CODES PER S-1400
CES-XXXX-CESSNA SPEC. NO.
S-XXX OR CMXXXX-CESSNA
STD. NO.

SUPERSEDES:
0410011 PG 5.3

SUPERSEDED BY:

CONTRACT NO:

DESIGN: *J.B. MITCHELL* 8-16-74
GROUP: *J. Brantford* 8-16-74
DRAWN: *B. FROMAN* 8-15-74
CHECK: *J. YOUEL* 8-15-74
STRESS:
PROJ: *H.D. Fife* 8-19-74
APPD:
OTHER:

COMMERCIAL AIRCRAFT DIV.
5800 E. PAWNEE
WICHITA, KANSAS

Cessna AIRCRAFT CO.

TITLE: **WIRING DIAGRAM — MAGNETOS**

SIZE: C
CODE IDENT. NO.: **71379**
DWG NO.: **0470401**

SCALE: NONE
150, A150, FA150
PAGE: 5.1

5800-522-000

Change 3 20-43

REVISION			
LET	DESCRIPTION	DATE	APPD
A	BY REV: DELETE S-1640-9, S-1641-9, PA3, DA3(REF); WIRE LENGTHS: S-1493-1/PB2 WAS S-1636-1 (MER E0339)	GS 9-13-74	APP MIL-1-REF
B	BY REV: S-1320-5 WAS S-1320-1; SER(SR7900)(SR7901)(SR7902)	CJH 11-27-74	APP MIL-1-REF

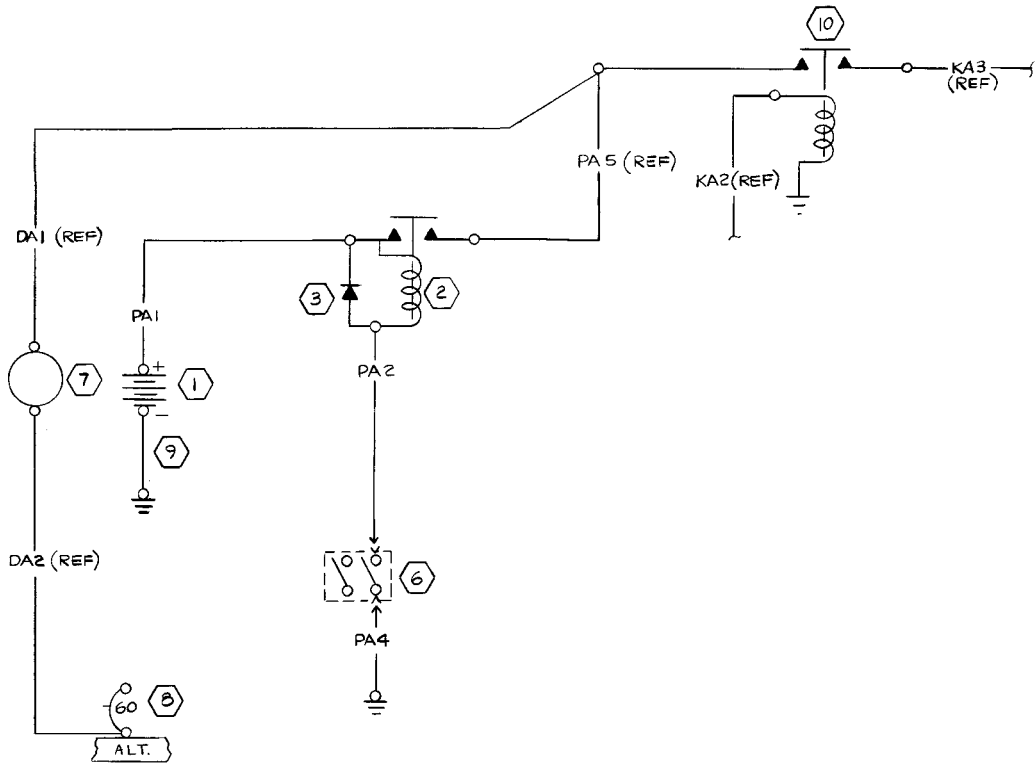

ITEM NO.	PART NO.	DESCRIPTION	WIRE CODE NO.	GA	MATERIAL	LG	TERMINALS	SERIALS
10	S-1991-1	STARTER CONTACTOR						
9	0412007-9	STRAP-BAT END						
8	S-1596-60L	CKT BREAKER						
7	S-1320-5	AMMETER						
6	S-1994-1-1	SWITCH-MASTER						
3	0770728-1	DIODE ASSY						
2	S-1579-2	CONTACTOR						
1	0511319-1	BATTERY, 12V						

ITEM NO.	PART NO.	DESCRIPTION
10	S-1991-1	STARTER CONTACTOR
9	0412007-9	STRAP-BAT END
8	S-1596-60L	CKT BREAKER
7	S-1320-5	AMMETER
6	S-1994-1-1	SWITCH-MASTER
3	0770728-1	DIODE ASSY
2	S-1579-2	CONTACTOR
1	0511319-1	BATTERY, 12V

CONTRACT NO:			COMMERCIAL AIRCRAFT DIV. 5800 E. PAWNEE WICHITA, KANSAS		
DESIGN	NAME	DATE	Cessna AIRCRAFT CO.		
GROUP	J.B. MITCHELL	8-16-74	TITLE		
DRAWN	B. FROMAN	8-15-74	WIRING DIAGRAM - BATTERY & STARTER CONTACTORS		
CHECK	J. YQUEL	8-15-74	SIZE	CODE IDENT. NO.	DWG NO.
STRESS			C	71379	0470401
PROJ	G. J. F.	8-19-74	SCALE: NONE	150 A150, FA150	PAGE: 6.1
APPD			(SR 7900)(SR 7901)(SR 7902)		
OTHER					

REVISION			
LET	DESCRIPTION	DATE	APPD
A	BY REV: DELETE S-1641-9, S-1640-9, KA2, WIRE LENGTHS; S-1367-1-10/ KA1 WAS S-1635-1 (MER E0339)	GS 9-13-74	<i>[Signature]</i> R.F.

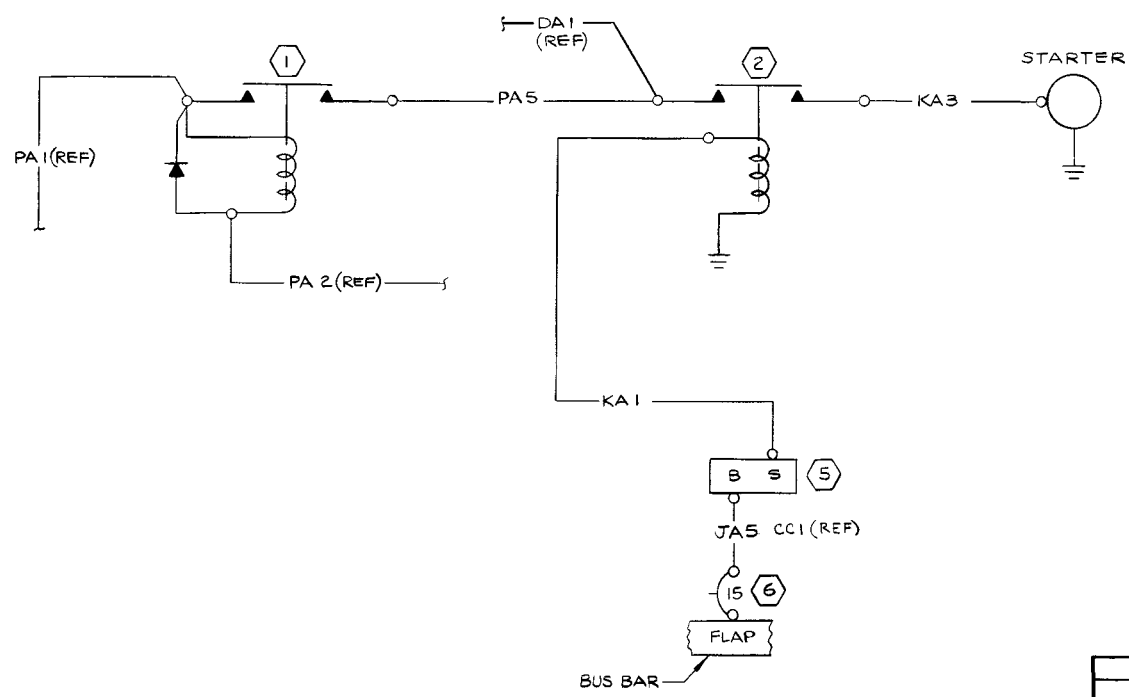

WIRE CODE NO	GA	MATERIAL	LG	TERMINALS	SERIALS
JAS	18		S-1367-1-10	S-1367-1-6	
PA5	4		S-1367-6-13	S-1367-6-13	
KA3	2		S-1367-7-13	S-1367-7-13	
KA1	18		S-1367-1-10	S-1367-1-0	

ITEM NO	PART NO.	DESCRIPTION
6	S-1360-15L	CIRCUIT BREAKER
5	C292501-0101	IGNITION SWITCH
2	S-1991-1	CONTACTOR
1	S-1579-2	CONTACTOR

CES-1000 IS APPLICABLE
VENDOR CODES PER S-1400
CES-XXXX-CESSNA SPEC. NO.
S-XXX OR CMXXXX-CESSNA
STD. NO.

SUPERSEDES:
0410011 PG 6.4

SUPERSEDED BY:

CONTRACT NO:			COMMERCIAL AIRCRAFT DIV. 5800 E. PAWNEE WICHITA, KANSAS		
DESIGN	NAME	DATE	TITLE		
JAS	J.B. MITCHELL	8-16-74	WIRING DIAGRAM — STARTER		
GROUP	<i>[Signature]</i>	8-16-74			
DRAWN	B. FROMAN	8-15-74			
CHECK	J. YOUEL	8-15-74			
STRESS					
PROJ	<i>[Signature]</i>	8-19-74	SIZE	CODE IDENT. NO.	DWG NO.
APPD			C	71379	0470401
OTHER			SCALE: NONE	150, A150, FA150	PAGE: 6, 2

(SR 7900)(SR 7901)(SR 7902)

Change 3 20-45

00-223-0905

REVISION

LET	DESCRIPTION	DATE	APPD
A	BY REV: DELETE S-1640-9, S-1641-9, EB2, WIRE LENGTHS; FUEL IND WAS INST LTS: S-1367-1-10/EB1 WAS S-1635-1 (MER E0339)	GS 9-13-74	<i>[Signature]</i> RF
B	BY REV: ADD S-1641-9 & S-1640-9; IN DETAIL B, PIN 4 WAS PIN 3, ITEM NO.3 WAS NO.7, ITEM NO.2 WAS NO.8 SER (SR 7900) (SR 7901) (SR 7902)	CJH 10-23-74	SCY <i>[Signature]</i> RF

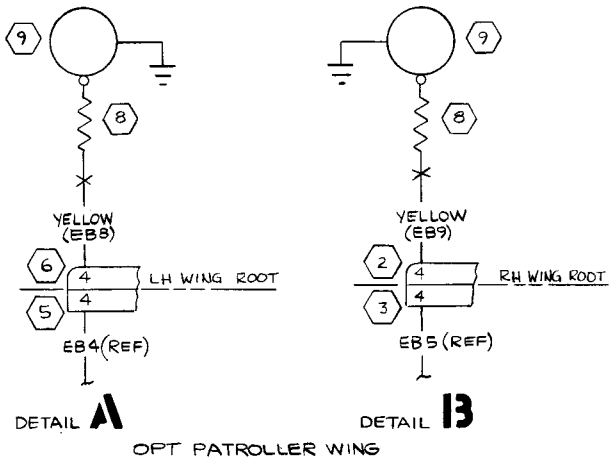
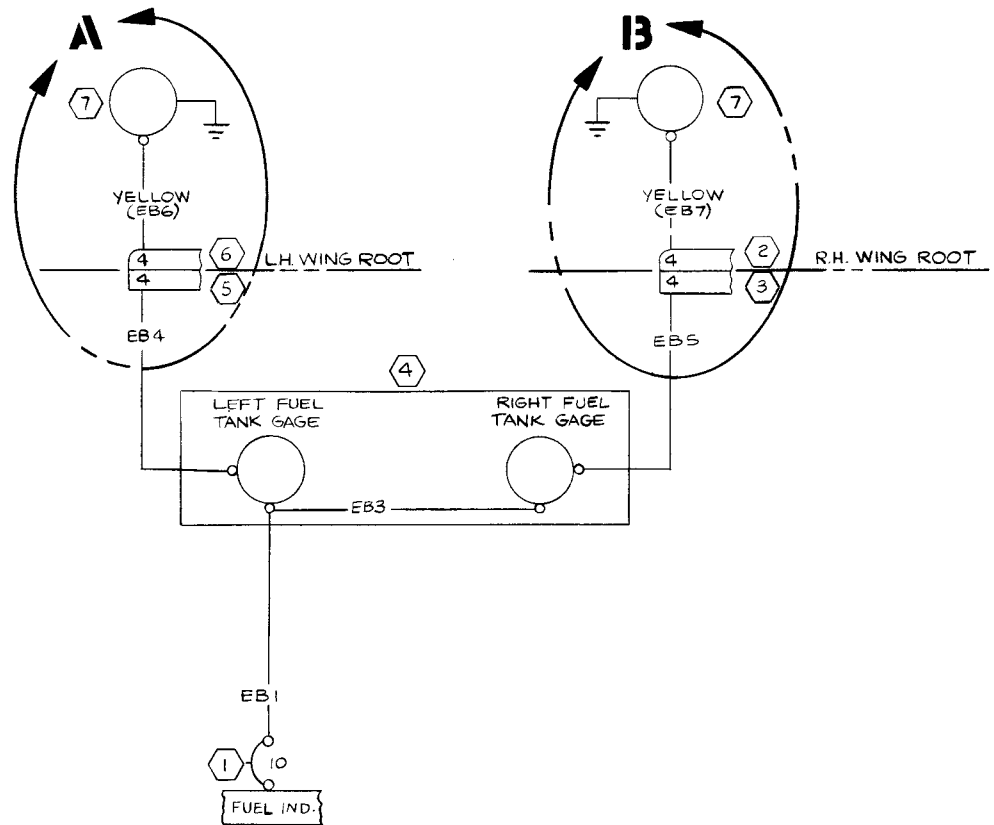

WIRE CODE NO	GA	MATERIAL	LG	TERMINALS	SERIALS
YEL (EB9)	18	-18-4		S-1635-1 S-1370-1 (OPT)	
YEL (EB3)	18	-18-4		S-1370-1 (OPT)	
YEL (EB7)	18	-18-4		S-1367-1-10	
YEL (EB5)	18	-18-4		S-1635-1 S-1367-1-10	
EB5	18			S-1367-1-10 S-1636-1	
EB4	18			S-1367-1-10 S-1636-1	
EB3	18			S-1367-1-10 S-1367-1-10	
EB1	18			S-1367-1-10 S-1367-1-6	

ITEM NO	PART NO.	DESCRIPTION
9	0426517-2	XMTR-FUEL LEVEL
8	20Ω 5W	RESISTOR
7	0426517-1	XMTR-FUEL LEVEL
6	S-1640-6	HOUSING-PIN
5	S-1641-6	HOUSING-SOCKET
4	0413035-1	PANEL ASSY
3	S-1641-9	HOUSING-SOCKET
2	S-1640-9	HOUSING-PIN
1	S-1360-10L	CKT BREAKER

WIRE TABLE

CONTRACT NO: _____

DESIGN	NAME	DATE
J.B. MITCHELL		8-16-74
B. FROMAN		8-15-74
J. YOUEL		8-15-74

COMMERCIAL AIRCRAFT DIV.
5800 E. PAWNEE
WICHITA, KANSAS

Cessna AIRCRAFT CO.

TITLE: **WIRING DIAGRAM - FUEL INDICATOR & TRANSMITTER**

PROJ	SIZE	CODE IDENT. NO.	DWG NO
C	NONE	71379	0470401

SCALE: NONE 150, A150, FA150 PAGE: 8.1

EQUIPMENT TABLE

CES-1000 IS APPLICABLE VENDOR CODES PER S-1400 CES-XXX-CESSNA SPEC. NO. S-XXX OR CMXXXX-CESSNA STD. NO.

SUPERSEDES: 0410011 PG 8.1.2

SUPERSEDED BY:

COO-223-C0905

REVISION			
LET	DESCRIPTION	DATE	APPD
A	BY REV: ADD GRN TO DC1 & RED TO DC2; DELETE WIRE LENGTHS (MERE0339)	65 9-13-74	<i>[Signature]</i> RF
B	BY REV: C664502-0106 WAS C664501-0103 ADD DFA; REVISE NOTE 1 (SR7900)(SR7901)(SR7902)	B.L.A. 10-14-74	<i>[Signature]</i> RF

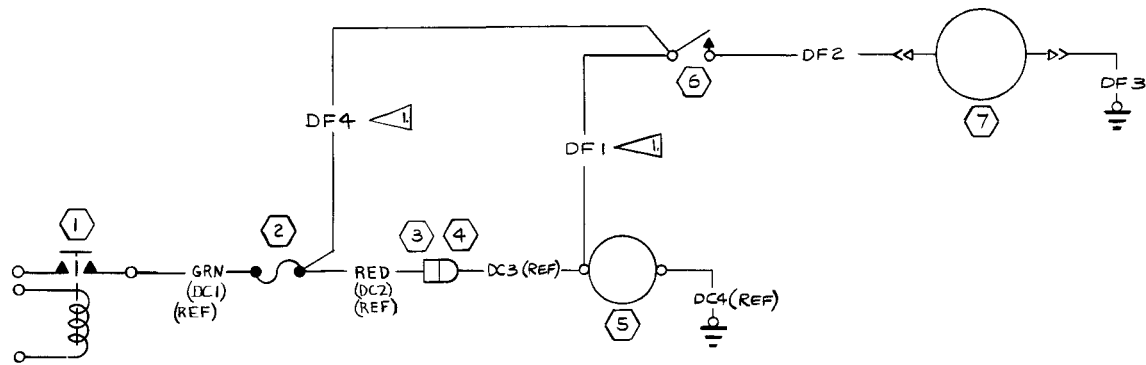

NOTES:

1. WIRING DIAGRAM SHOWN IS FOR USE WHEN AN OPTIONAL ELECTRIC CLOCK IS INSTALLED. WHEN ELECTRIC CLOCK IS NOT INSTALLED DF4 REPLACES DF1

ITEM NO.	PART NO.	DESCRIPTION
7	C664502-0101	HOURMETER
6	S-1711-1	OIL PRESSURE SW.
5	S-1317N1	CLOCK
4	S-1637-1	HOUSING
3	S-1637-2	HOUSING
2	S-1091-1	FUSE
1	S-1579-2	CONTACTOR

CES-1000 IS APPLICABLE VENDOR CODES PER S-1400 CES-XXXX-CESSNA SPEC. NO. S-XXX OR CMXXXX-CESSNA STD. NO.

SUPERSEDES: 041001 PG 8.2

SUPERSEDED BY:

WIRE CODE NO.	GA	MATERIAL	LG	TERMINALS	SERIALS
DF4	18			SOLDER	S-1367-1-6
DF3	18			S-1499-1	S-1367-1-8
DF2	18			S-1499-1	S-1367-1-6
DF1	18			S-1367-1-6	S-1367-1-6

CONTRACT NO:		WIRE TABLE	
DESIGN	NAME	DATE	TITLE
J.B. MITCHELL		8-16-74	COMMERCIAL AIRCRAFT DIV. 5800 E. PAWNEE WICHITA, KANSAS
B. FROMAN		8-16-74	WIRING DIAGRAM - HOURMETER (OPT)
J. YOWEL		8-15-74	
PROJ		8-19-74	SIZE
APPD			CODE IDENT.
OTHER			DWG NO
			C
			71379
			0470401
			SCALE: NONE
			150, A150, FA150
			PAGE: 8, 2

(SR7900)(SR7901)(SR7902)

REVISION			
LET	DESCRIPTION	DATE	APPD
A	BY REV: DELETE S-1640-9, S-1641-9, FA 2, FA 4 (REF); NAV/DOME LTS WAS NAV LTS/ T&B IND; S-1367-1-8/FA1 WAS S-1635-1; ADD LDI (REF) & LAI (REF); DELETE WIRE LENGTHS (MER E0339)	GS 9-13-74	<i>GRS</i> <i>MLK</i> RF

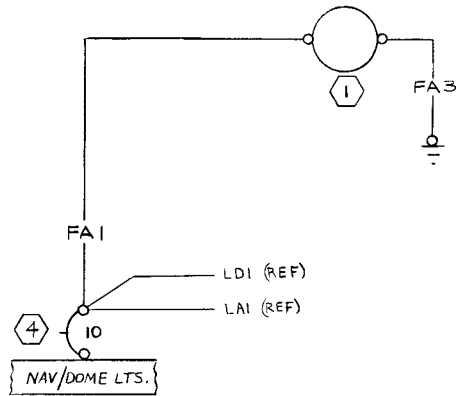

WIRE CODE NO	GA	MATERIAL	LG	TERMINALS	SERIALS
FA 3	18			S-1367-1-8 S-1367-1-8	
FA 1	18			S-1367-1-8 S-1367-1-8	

EQUIPMENT TABLE			WIRE TABLE																	
4	S-1360-10L	CKT BREAKER	CONTRACT NO:																	
1	S-1302N1	T&B INDICATOR	<table border="1"> <thead> <tr> <th>DESIGN</th> <th>NAME</th> <th>DATE</th> </tr> </thead> <tbody> <tr> <td>J.B. MITCHELL</td> <td></td> <td>8-16-74</td> </tr> <tr> <td>B. FROMAN</td> <td></td> <td>8-15-74</td> </tr> <tr> <td>J. YUCEL</td> <td></td> <td>8-15-74</td> </tr> <tr> <td>G.D. Fife</td> <td></td> <td>8-19-74</td> </tr> </tbody> </table>			DESIGN	NAME	DATE	J.B. MITCHELL		8-16-74	B. FROMAN		8-15-74	J. YUCEL		8-15-74	G.D. Fife		8-19-74
DESIGN	NAME	DATE																		
J.B. MITCHELL		8-16-74																		
B. FROMAN		8-15-74																		
J. YUCEL		8-15-74																		
G.D. Fife		8-19-74																		
CES-1000 IS APPLICABLE VENDOR CODES PER S-1400 CES-XXXX-CESSNA SPEC. NO. S-XXX OR CMXXXX-CESSNA STD. NO.			COMMERCIAL AIRCRAFT DIV. 5800 E. PAWNEE WICHITA, KANSAS																	
SUPERSEDES: 0410011 PG 9.2.1			TITLE WIRING DIAGRAM — TURN & BANK (OPT)																	
SUPERSEDED BY:			SIZE CODE IDENT. DWG NO C 71379 0470401																	
SCALE: NONE			150, A150, FA150 PAGE: 9.1																	

00-223-0905

REVISION			
LET	DESCRIPTION	DATE	APPD
A	BY REV: DELETE S-1640-9, S-1641-9, FA1(REF), FA2(REF), WIRE LENGTHS; S-1636-1/FA4 WAS "SEE FAZ" (MERE0339)	GS 9-13-74	<i>[Signature]</i> RF

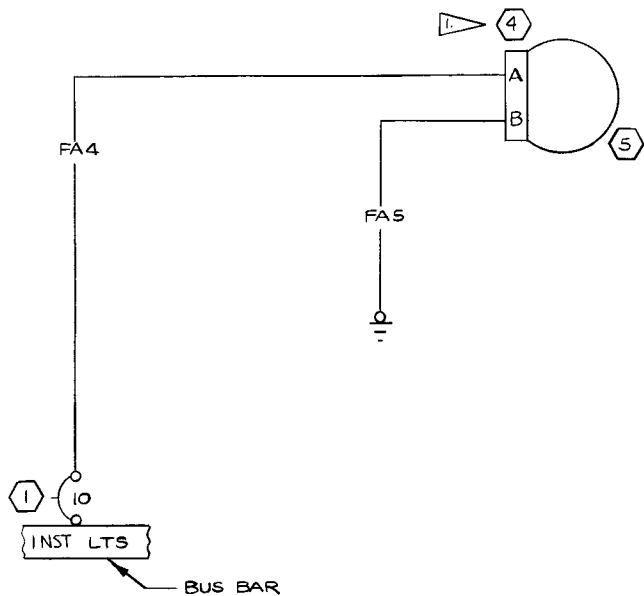

NOTES:

▶ MS3106A10SL35 CONNECTOR IS SUPPLIED BY VENDOR.

WIRE CODE NO	GA	MATERIAL	LG	TERMINALS	SERIALS
FA 5	18			SOLDER S-1367-1-8	
FA 4	18			SOLDER S-1367-1-8	

ITEM NO.	PART NO.	DESCRIPTION
5	CG61003-0501	TURN COORDINATOR
4	MS3106A10SL35	CONNECTOR ▶ 1
1	S-1360-10L	CKT BREAKER

EQUIPMENT TABLE	
PART NO.	DESCRIPTION
5	CG61003-0501 TURN COORDINATOR
4	MS3106A10SL35 CONNECTOR ▶ 1
1	S-1360-10L CKT BREAKER

CES-1000 IS APPLICABLE VENDOR CODES PER S-1400 CES-XXXX-CESSNA SPEC. NO. S-XXX OR CMXXXX-CESSNA STD. NO.

SUPERSEDES: 0410011 PG 9.4

SUPERSEDED BY:

CONTRACT NO:		COMMERCIAL AIRCRAFT DIV. 5800 E. PAWNEE WICHITA, KANSAS	
DESIGN	J.B. MITCHELL	DATE	8-16-74
GROUP	<i>[Signature]</i>	DATE	8-16-74
DRAWN	B. FROMAN	DATE	8-15-74
CHECK	J. YOUEL	DATE	8-15-74
STRESS	<i>[Signature]</i>	DATE	8-19-74
PROJ		APPD	
OTHER			
SIZE	C	CODE IDENT. NO.	71379
DWG NO			0470401
SCALE	NONE	150, A150, FA150	PAGE: 9.2

(SR 7900) (SR 7901) (SR 7902)

Change 3 20-49

REVISION			
LET	DESCRIPTION	DATE	APPD

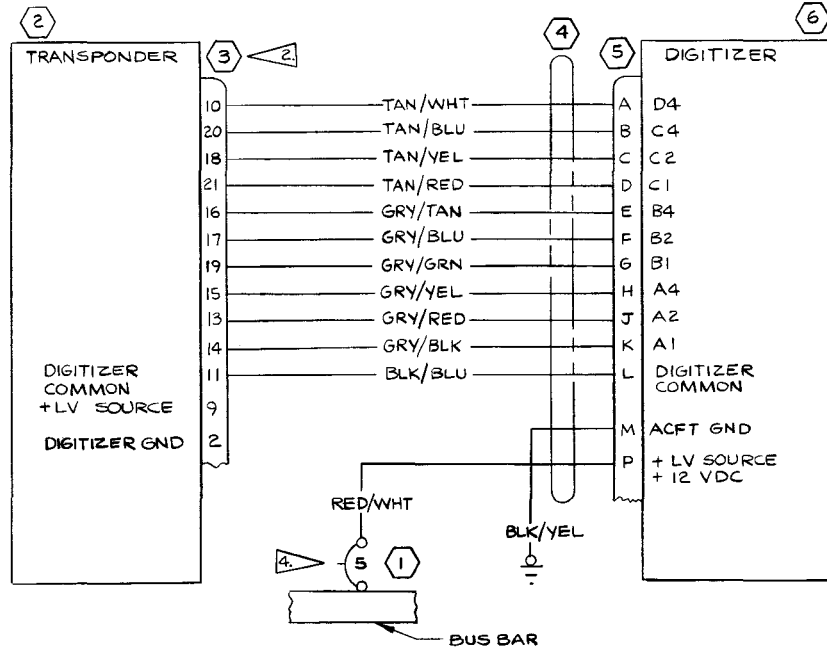

NOTES:

1. PINS ARE CRIMP TYPE AND ARE FURNISHED BY VENDOR WITH CONNECTOR.
2. TRANSPONDER CONNECTOR HOUSING IS PART OF TRANSPONDER CABLE ASSY.
3. FOR WIRING DIAGRAM OF 300 TRANSPONDER REFER TO 3920143.
4. ATTACH BOTH TRANSPONDER AND ENCODING ALTIMETER TO THE NO. 3 CIRCUIT BREAKER
5. FOR WIRES & TERMINALS SEE 1270625 PG 97

WIRE CODE NO.	GA	MATERIAL	LG	TERMINALS	SERIALS

ITEM NO.	PART NO.	DESCRIPTION
6	EA-401A	ALT DIGITIZER
5	42816	CONNECTOR
4	1570312-2	CABLE ASSY
3	S-2189-1	CONNECTOR
2	RT-359A	TRANSPONDER
1	S-1360-5L	CKT BREAKER

EQUIPMENT TABLE

CES-1000 IS APPLICABLE
VENDOR CODES PER S-1400
CES-XXXX*CESSNA SPEC. NO.
S-XXX OR CMXXXX*CESSNA
STD. NO.

SUPERSEDES:
O410011 PG 9.6

SUPERSEDED BY:

WIRE TABLE

CONTRACT NO:

DESIGN NAME DATE: J.B. MITCHELL 8-16-74

GROUP

DRAWN B. FROMAN 8-15-74

CHECK J. YOUEL 8-15-74

STRESS

PROJ G. R. Life 8-19-74

APPD

OTHER

COMMERCIAL AIRCRAFT DIV.
5800 E. PAWNEE
WICHITA, KANSAS

Cessna AIRCRAFT CO.

TITLE
**WIRING DIAGRAM —
ENCODING ALTIMETER
(OPT)**

SIZE C

CODE IDENT. NO. 71379

DWG NO. O470401

SCALE: NONE 150, A150, FA150

PAGE: 9, 3

(SR 7900)(SR 7901)(SR 7902)

REVISION			
LET	DESCRIPTION	DATE	APPD
A	BY REV: C664508-0101 WAS S-1317-N2 ADD GRN TO DC1. 0712031-2 WAS S-1091-1. DELETE WIRE LENGTHS. (MER E0339)(SR7900)(SR7901)(SR7902)	GEC 9-13-74	<i>[Signature]</i> APP MPT RF

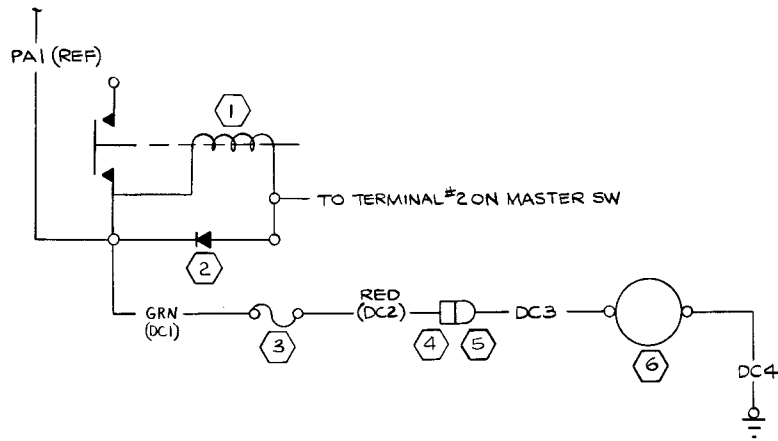

00-223-0905

WIRE CODE NO	GA	MATERIAL	LG	TERMINALS	SERIALS
DC 4	18			S-1367-1-8 S-1367-1-6	
DC 3	18			S-1635-1 S-1367-1-6	
RED (DC2)	18	-18-2		S-1636-1 SOLDER	
GRN (DC1)	18	-18-5		S-1367-1-6 SOLDER	

ITEM NO	PART NO.	DESCRIPTION
6	C664508-0101	CLOCK ASSY
5	S-1637-1	HOUSING
4	S-1637-2	HOUSING
3	0712031-2	FUSE
2	0770728-1	DIODE ASSY
1	S-1579-2	CONTACTOR

CES-1000 IS APPLICABLE
VENDOR CODES PER S-1400
CES-XXXX*CESSNA SPEC. NO.
S-XXX OR CMXXXX*CESSNA
STD. NO.

SUPERSEDES:
0410011 PG 10.1
SUPERSEDED BY:

CONTRACT NO:				COMMERCIAL AIRCRAFT DIV. 5800 E. PAWNEE WICHITA, KANSAS	
DESIGN	J.B. MITCHELL	DATE	8-16-74	TITLE WIRING DIAGRAM — CLOCK (OPT)	
GROUP	<i>[Signature]</i>	DATE	8-16-74		
DRAWN	B. FROMAN	DATE	8-15-74		
CHECK	J. YOEEL	DATE	8-15-74		
STRESS					
PROJ	<i>[Signature]</i>	DATE	8-19-74	SIZE	CODE IDENT. DWG NO
APPD				C	71379 0470401
OTHER				SCALE: NONE	150, A150, FA150 PAGE: 10.1

(SR 7900)(SR 7901)(SR 7902)

Change 3 20-51

REVISION			
LET	DESCRIPTION	DATE	APPD
A	BY REV; DELETE S-1640-9, S-1641-9, LA3, WIRE LENGTHS; 0470112-1 WAS S-1641-9; S-1637-1 WAS S-1640-9; S-1635-1/LA2 WAS S-1636-1; NAV/DOME WAS INST LTS; ADD FA1 (REF) & LDI (REF) (MER E033)	CJH GS 9-13-74	<i>JRS</i> RF

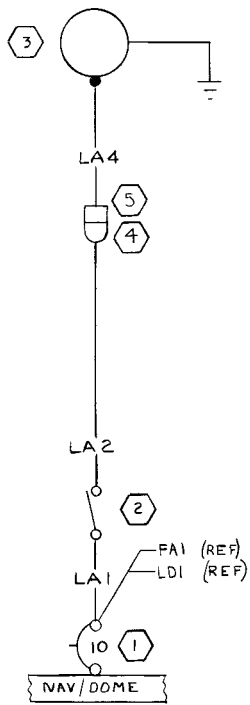

WIRE CODE NO.	GA	MATERIAL	LG	TERMINALS	SERIALS
LA 4	18			SOLDER	S-1636-1
LA 2	18			S-1493-1	S-1635-1
LA 1	18			S-1493-1	S-1361-1-6

ITEM NO.	PART NO.	DESCRIPTION
5	S-1637-2	HOUSING-SOCKET
4	S-1637-1	HOUSING - PIN
3	0470112-1	SUPPORT ASSY
2	S-2160-1	SWITCH
1	S-1360-10L	CKT BREAKER

CES-1000 IS APPLICABLE
VENDOR CODES PER S-1400
CES-XXXX-CESSNA SPEC. NO.
S-XXX OR CMXXXX-CESSNA
STD. NO.

SUPERSEDES:
0410011 PG 11.1.3
SUPERSEDED BY:

CONTRACT NO:		
DESIGN	J.B. MITCHELL	8-16-74
GROUP	<i>B. Froman</i>	8-16-74
DRAWN	B. FROMAN	8-15-74
CHECK	J. YOWEL	8-15-74
STRESS		
PROJ	<i>Safe</i>	8-19-74
APPD		
OTHER		

COMMERCIAL AIRCRAFT DIV.
5800 E. PAWNEE
WICHITA, KANSAS

Cessna AIRCRAFT CO.

TITLE
**WIRING DIAGRAM -
DOME LIGHT**

SIZE: C
CODE IDENT. NO.: 71379
DWG NO: 0470401

SCALE: NONE | 150, 150, FA150 | PAGE: 11.1
(SR 7900)(SR 7901)(SR 7902)

00-223-0905

REVISION			
LET	DESCRIPTION	DATE	APPD
B	BY REV: REVISED & REDRAWN (MERO 354) (SR 7900)(SR 7901)(SR 7902)	BLA 10-3-74	SCF RF RF
C	BY REV: DELETE NOTE, DWG COMPLETE (SR 7900)(SR 7901)(SR 7902)	BLA 1-13-74	SCF

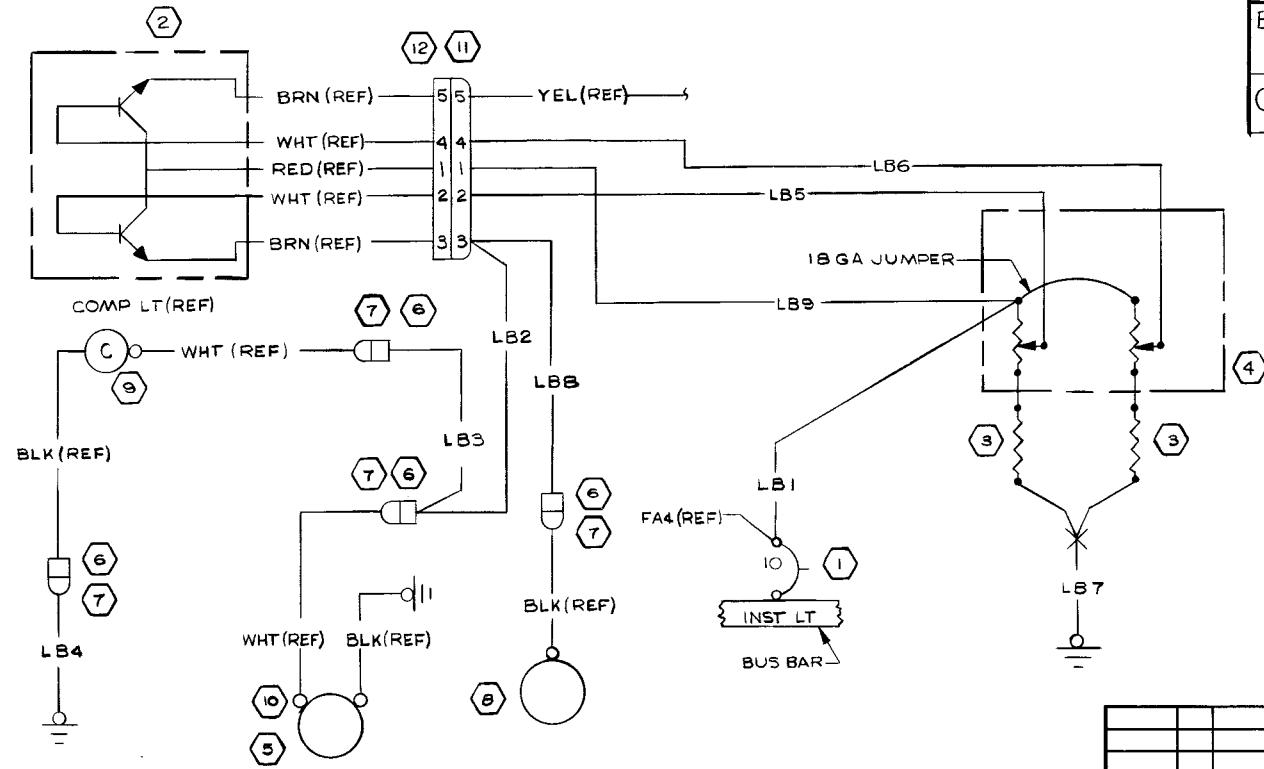

ITEM NO	GA	MATERIAL	LG	TERMINALS	SERIALS
LB9	18	S-1635-1		SOLDER	
LB8		S-1635-2		S-1636-2	
LB7		S-1370-1		S-1367-1B	
LB6		S-1635-1		SOLDER	
LB5		S-1635-1		SOLDER	
LB4		S-1635-1		S-1367-1B	
LB3		S-1636-2		S-1636-1	
LB2		SEE LB3		SEE LB8	
LB1	18	S-1367-14		SOLDER	

ITEM NO	PART NO.	DESCRIPTION
12	S-1641-6	HOUSING-SOCKET
11	S-1640-6	HOUSING-PIN
10	25-207	SOCKET
9	C660501-0101	COMPASS ASSY
8	O470112-1	SUPPORT ASSY
7	S-1637-1	HOUSING SOCKET
6	S-1637-2	HOUSING PLUG
5	S-1894-3	BULB
4	S-2091-5	RESISTOR ASSY
3	S2000B270J	RESISTOR
2	1570166	DIMMING ASSY
1	S-1360-10L	CKT BREAKER

EQUIPMENT TABLE	
CES-1000 IS APPLICABLE VENDOR CODES PER S-1400 CES-XXXX-CESSNA SPEC. NO. S-XXX OR CMXXXX-CESSNA STD. NO.	SUPERSEDES: REV "A" SUPERSEDED BY:

WIRE TABLE			CONTRACT NO:	
DESIGN	J.B. MITCHELL	8-16-74		
GROUP	J. GRANDFIELD	8-16-74		
DRAWN	B. FROMAN	8-15-74		
CHECK	J. YUCEL	8-15-74		
STRESS			PROJ	R. FIFE
			APPD	
			OTHER	
TITLE			SIZE	CODE IDENT.
WIRING DIAGRAM - INSTRUMENT LIGHTS			C	71379
			DWG NO	0470401
SCALE: NONE			150 ALSO FAI 50	PAGE: 11.2

(SR 7900)(SR 7901)(SR 7902)

Change 3 20-53

00-223-0905

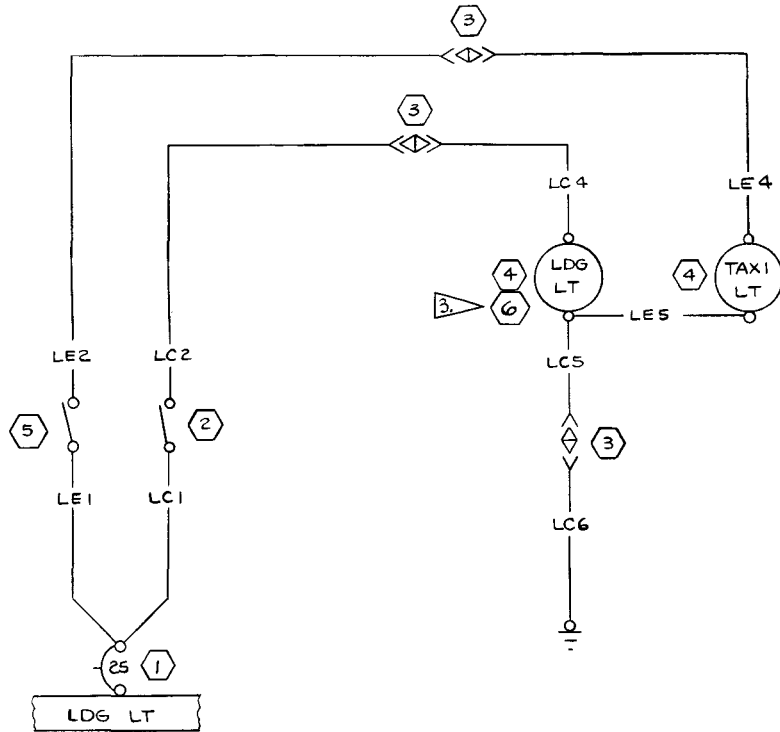

REVISION			
LET	DESCRIPTION	DATE	APPD
A	BY REV: DELETE WIRE LENGTH (SR7900)(SR7901)(SR7902)	C J H 9-13-74	<i>[Signature]</i> RF
B	BY REV: ADD NOTES 2 & 3, 4313, OPT TO TITLE; DELETE OPT FROM WIRE TABLE, LC3, LE3, & 57904-1/LC2&LE2; SER(SR7900)(SR7901)(SR7902)	C J H 9-24-74	<i>[Signature]</i> RF

NOTES:

- LANDING LT WIRING IS STANDARD EQUIPMENT FOR DOMESTIC ACFT; LANDING AND TAXI LIGHT WIRING IS STANDARD EQUIPMENT FOR FRENCH ACFT AND OPTIONAL EQUIPMENT FOR DOMESTIC ACFT.
- LE NUMBERED WIRES USED ON DUAL INSTL ONLY
- USE ON SINGLE LIGHT INSTL ONLY

WIRE NO.	GA	MATERIAL	LG	TERMINALS	SERIALS
LE 5	12			S-1367-3-8	S-1367-3-8
LE 4	12			S-1493-3	S-1367-3-8
LE 2	12			S-1493-3	S-1493-3
LE 1				S-1493-3	S-1367-1-6
LC 6				S-1493-3	S-1367-3-6
LC 5				S-1367-3-8	S-1493-3
LC 4	12			S-1493-3	S-1367-3-8
LC 2	12			S-1493-3	S-1493-3
LC 1	12			S-1493-3	S-1367-1-6

ITEM NO.	PART NO.	DESCRIPTION
6	4313	LAMP
5	S-2160-5	SWITCH
4	4509	100WATT PAR 3 LAMP
3	S-2064-1	CONNECTOR
2	S-2160-4	SWITCH
1	S-1360-25L	CKT BREAKER

EQUIPMENT TABLE	
CES-1000 IS APPLICABLE	SUPERSEDES: 0410011 PG 11.3.4
VENDOR CODES PER S-1400	SUPERSEDED BY:
CES-XXXX-CESSNA SPEC. NO.	
S-XXX OR CMXXXX-CESSNA	
STD. NO.	

CONTRACT NO:			WIRE TABLE		
DESIGN	J.B. MITCHELL	8-16-74	COMMERCIAL AIRCRAFT DIV. 5800 E. PAWNEE WICHITA, KANSAS		
GROUP	<i>[Signature]</i>	8-16-74	TITLE		
DRAWN	B. FROMAN	8-15-74	WIRING DIAGRAM —		
CHECK	J. YOWEL	8-15-74	LANDING & TAXI LIGHTS		
STRESS			(OPTIONAL)		
PROJ	<i>[Signature]</i>	8-19-74	SIZE	CODE IDENT. NO.	DWG NO
APPD			C	71379	0470401
OTHER			SCALE: NONE	150, A150, FA150	PAGE: 11.3

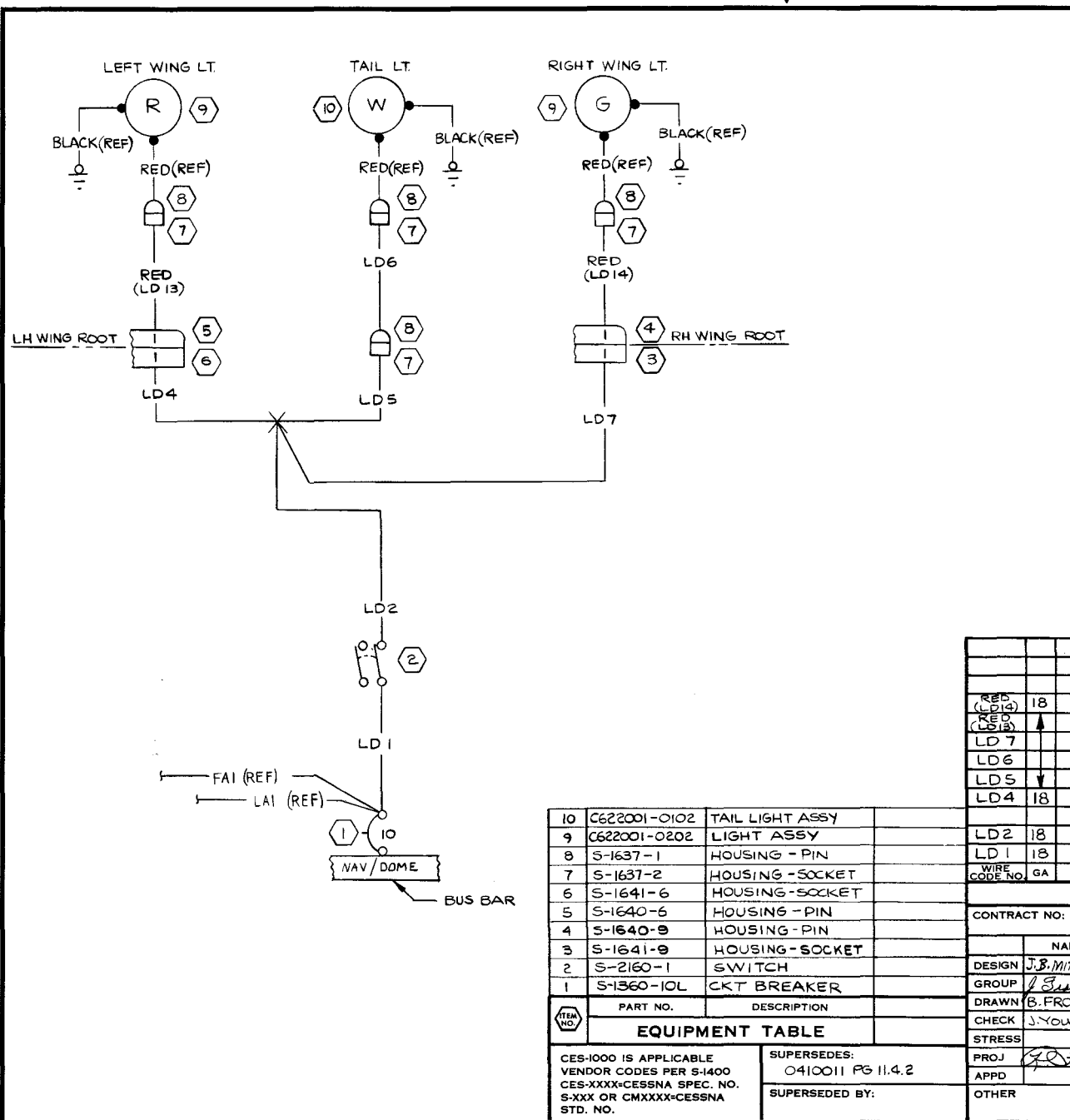

REVISION			
LET	DESCRIPTION	DATE	APPD
A	BY REV: DELETE S-1640-9, S-1641-9, S-1370-2, WIRE LENGTHS; NAV/DOME WAS NAV LTS; S-1635-1/LDZ WAS S-1636-1 (MER E0339)	CTH GS 7-13-74	<i>[Signature]</i> RF
B	BY REV: ADD S-1640-9 & S-1641-9 SER(SR7900)(SR7901)(SR7902)	BLA 10-14-74	<i>[Signature]</i> RF

00-229-0905

ITEM NO.	PART NO.	DESCRIPTION	GA	MATERIAL	LG	TERMINALS	SERIALS
REF (LD14)	18	-18-2		S-1635-1		S-1636-1	
REF (LD13)		-18-2		S-1635-1		S-1636-1	
LD 7				SEE LD 5		S-1636-1	
LD 6				S-1635-1		S-1636-1	
LD 5				S-1370-1		S-1636-1	
LD 4	18			SEE LD 5		S-1636-1	
LD 2	18			S-1493-1		SEE LD 5	
LD 1	18			S-1493-1		S-1367-1-6	

ITEM NO.	PART NO.	DESCRIPTION
10	C622001-0102	TAIL LIGHT ASSY
9	C622001-0202	LIGHT ASSY
8	S-1637-1	HOUSING - PIN
7	S-1637-2	HOUSING - SOCKET
6	S-1641-6	HOUSING - SOCKET
5	S-1640-6	HOUSING - PIN
4	S-1640-9	HOUSING - PIN
3	S-1641-9	HOUSING - SOCKET
2	S-2160-1	SWITCH
1	S-1360-10L	CKT BREAKER

WIRE TABLE

CONTRACT NO: _____

DESIGN: J.B. MITCHELL 8-16-74
 GROUP: *[Signature]* 7-16-74
 DRAWN: B. FROMAN 8-15-74
 CHECK: J. YUCEL 8-15-74
 STRESS: *[Signature]* 8-19-74

COMMERCIAL AIRCRAFT DIV.
 5800 E. PAWNEE
 WICHITA, KANSAS

Cessna AIRCRAFT CO.

TITLE: **WIRING DIAGRAM - NAVIGATION LIGHTS**

SIZE: C
 CODE IDENT. NO.: 71379
 DWG NO.: 0470401

SCALE: NONE
 150, A150, FA150
 PAGE: 11.4

EQUIPMENT TABLE

CES-1000 IS APPLICABLE
 VENDOR CODES PER S-1400
 CES-XXXX-CESSNA SPEC. NO.
 S-XXX OR CMXXXX-CESSNA
 STD. NO.

SUPERSEDES:
 0410011 PG 11.4.2

SUPERSEDED BY:

(SR7900)(SR7901)(SR7902)

Change 3 20-55

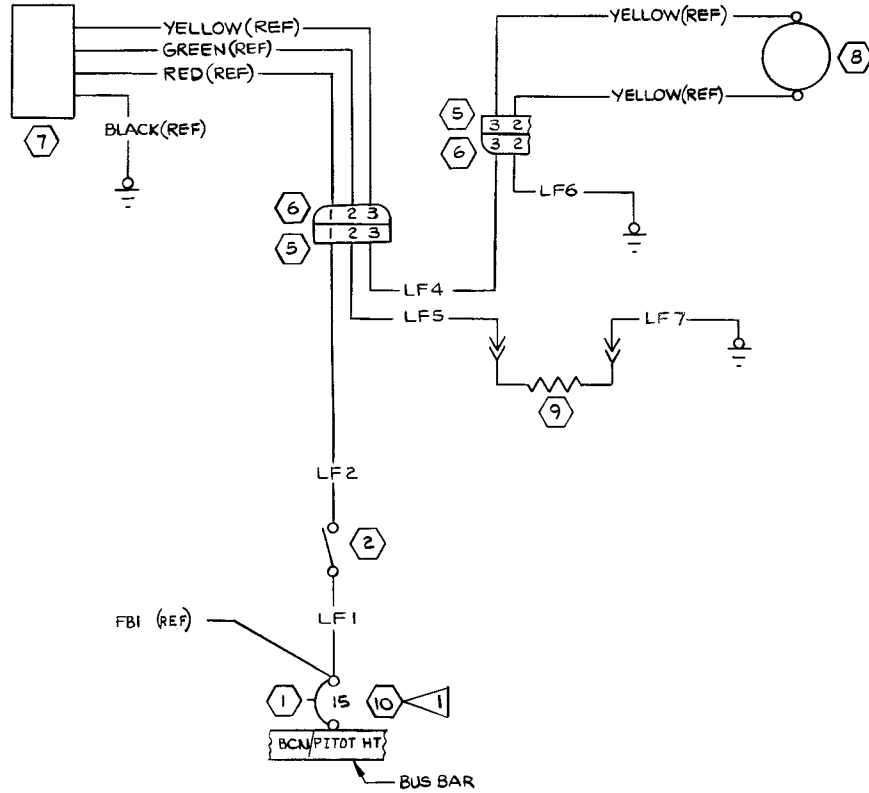

NOTES:

▲ THE 20 AMP CIRCUIT BREAKER IS TO BE USED WHEN THE FLASHING BEACON IS INSTALLED WITH PITOT HEAT.

REVISION			
LET	DESCRIPTION	DATE	APPD
A	BY REV: DELETE S-1640-9, S-1641-9, LF3, WIRE LENGTH; ADD FBI (REF); BCN PITOT HT WAS BCN (MERE0339)	CJH GS 9-13-74	<i>[Signature]</i>
B	BY REV: S-1360-15L WAS S-1360-10L; LF1+LF2/14 GA WIRE WAS 16 GA (SRB260)	BAH 5-13-75	<i>[Signature]</i>

(15077006, A1500610, F150010496, FA150282)

00-223-0905

ITEM NO.	PART NO.	DESCRIPTION
10	S-1360-20L	CKT BREAKER
9	OR95-15	RESISTOR
8	C621001-0106	LIGHT ASSY
7	C594502-0101	FLASHER ASSY
6	S-1638-2	HOUSING-CAP
5	S-1638-1	HOUSING-PLUG
2	S-2160-1	SWITCH
1	S-1360-15L	CKT BREAKER

ITEM NO.	PART NO.	DESCRIPTION
EQUIPMENT TABLE		

CES-1000 IS APPLICABLE
VENDOR CODES PER S-1400
CES-XXXX-CESSNA SPEC. NO.
S-XXX OR CMXXXX-CESSNA
STD. NO.

SUPERSEDES:
0410011 PG 11.6.1
SUPERSEDED BY:

WIRE CODE NO.	GA	MATERIAL	LG	TERMINALS	SERIALS
LF7	16		S-1493-2	S-1367-2-8	
LF6	16		S-1635-2	S-1367-2-8	
LF5	16		S-1493-2	S-1636-2	
LF4	16		S-1635-2	S-1636-2	
LF2	14		S-1493-2	S-1636-2	
LF1	14		S-1493-2	S-1367-2-6	

CONTRACT NO:			Cessna AIRCRAFT CO. COMMERCIAL AIRCRAFT DIV. 5800 E. PAWNEE WICHITA, KANSAS		
DESIGN	NAME	DATE	TITLE		
GROUP	J.B. MITCHELL	8-16-74	WIRING DIAGRAM — LIGHT-FLASHING BEACON (OPTIONAL)		
DRAWN	B. FROMAN	8-15-74			
CHECK	J. YOWEL	8-15-74			
STRESS			SIZE	CODE IDENT. NO.	DWG NO
PROJ	R. J. Fife	8-19-74	C	71379	0470401
APFD			SCALE: NONE	150, A150, FA150	PAGE: 11, 5
OTHER					

(SR 7900)(SR 7901)(SR 7902)

REVISION			
LET	DESCRIPTION	DATE	APPD
A	BY REV: NAV/DOME LTS WAS NAV LTS; DELETE WIRE LENGTH (MER E0339)	C J H 9-13-74	<i>[Signature]</i>

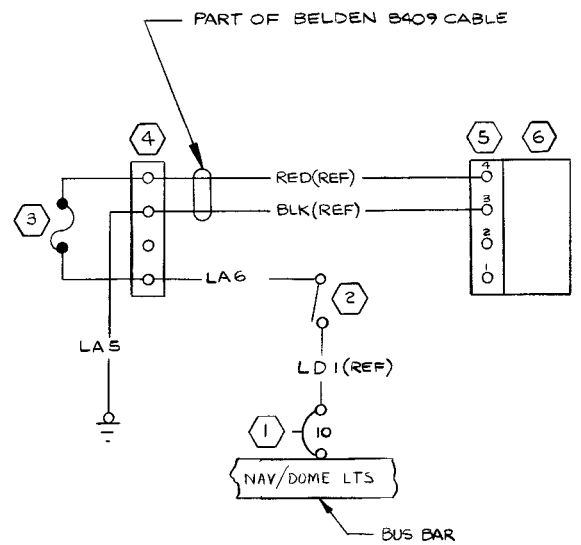

00-223-0905

WIRE CODE NO	GA	MATERIAL	LG	TERMINALS	SERIALS
LA6	20			5-1367-1-329636 (00779)	
LAS	20			5-1493-1-329636 (00779)	

ITEM NO.	PART NO.	DESCRIPTION
6	0570088-1	MAPLIGHT ASSY
5	520-4	TERMINAL BLOCK
4	5-171	TERMINAL BLOCK
3	1570141-1	FUSE ASSY
2	S-2160-1	SWITCH
1	S-1360-10L	CKT BREAKER

EQUIPMENT TABLE	
CES-1000 IS APPLICABLE VENDOR CODES PER S-1400 CES-XXX-CESSNA SPEC. NO. S-XXX OR CMXXXX-CESSNA STD. NO.	SUPERSEDES: 0410011 PG 11.7.1 SUPERSEDED BY:

CONTRACT NO:		COMMERCIAL AIRCRAFT DIV. 5800 E. PAWNEE WICHITA, KANSAS	
DESIGN	J. B. MITCHELL	DATE	8-16-74
GROUP	<i>[Signature]</i>	DATE	8-16-74
DRAWN	B. FROMAN	DATE	8-15-74
CHECK	J. YOUEL	DATE	8-15-74
STRESS			
PROJ	<i>[Signature]</i>	DATE	8-19-74
APPD			
OTHER			

TITLE WIRING DIAGRAM — MAPLIGHT- CONTROL WHEEL	
SIZE	C
CODE IDENT. NO.	71379
DWG NO	0470401
SCALE:	NONE 150, A150, FA150
PAGE:	11.6

(SR7900)(SR7901)(SR7902)

Change 3 20-57

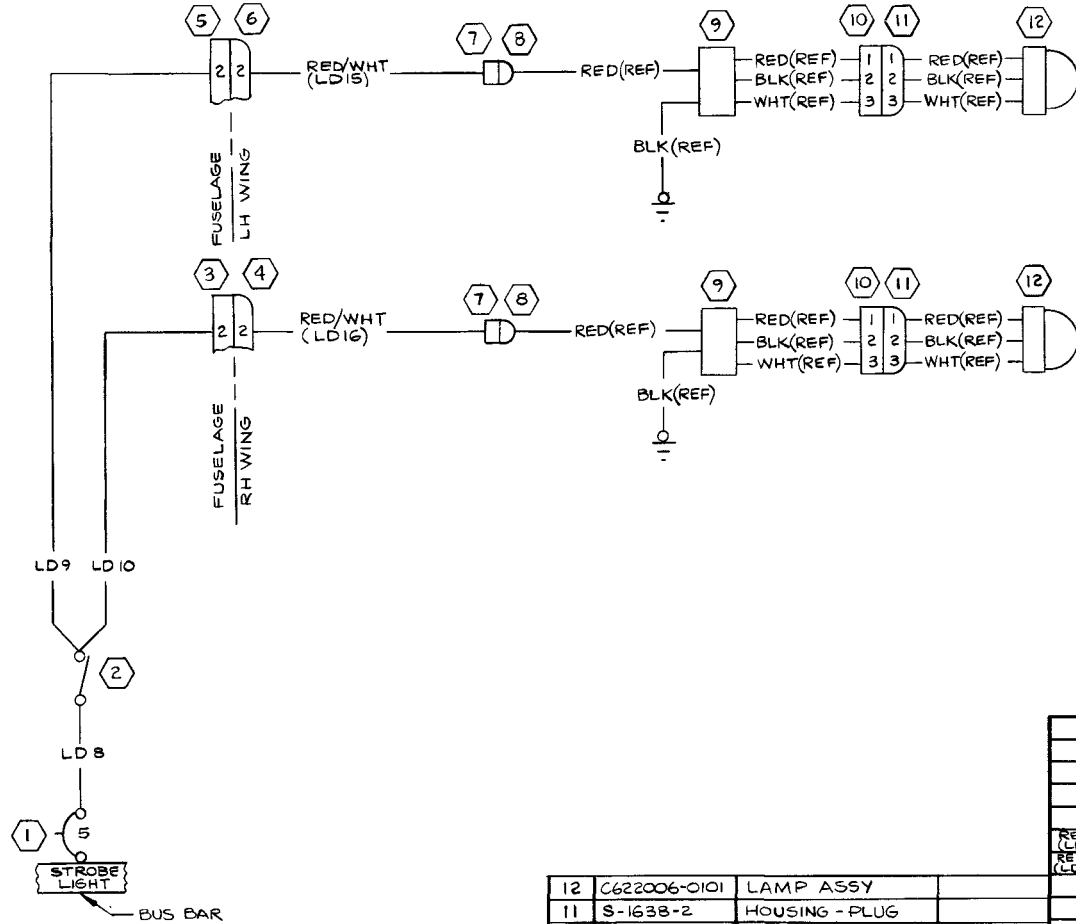

REVISION			
LET	DESCRIPTION	DATE	APPD
A	BY REV: DELETE S-1640-9 (I), S-1641-9 (I), LD-11, LD12, & WIRE LENGTHS (MER E0339)	CTH GS 9-13-74	[Signature]

ITEM NO.	PART NO.	DESCRIPTION
12	C622006-0101	LAMP ASSY
11	S-1638-2	HOUSING - PLUG
10	S-1638-1	HOUSING - PIN
9	C622007-0101	POWER SUPPLY
8	S-1637-1	HOUSING - PLUG
7	S-1637-2	HOUSING - PLUG
6	S-1640-6	HOUSING - PIN
5	S-1641-6	HOUSING - SOCKET
4	S-1640-9	HOUSING - PIN
3	S-1641-9	HOUSING - SOCKET
2	S-2160-1	SWITCH
1	S-1360-5L	CKT BREAKER

EQUIPMENT TABLE

CES-1000 IS APPLICABLE
VENDOR CODES PER S-1400
CES-XXXX-CESSNA SPEC. NO.
S-XXX OR CMXXXX-CESSNA
STD. NO.

SUPERSEDES:
0410011 PG 11.8.1

SUPERSEDED BY:

WIRE CODE NO.	GA	MATERIAL	LG	TERMINALS	SERIALS
RED/WHT (LD 6)	18	-18-2-9	S-1635-1	S-1636-1	(STD)
RED/WHT (LD 8)	18	-18-2-9	S-1635-1	S-1636-1	(STD)
LD 10	18		SEE LD 10	S-1636-1	
LD 9	18		S-1493-2	S-1636-1	
LD 8	18		S-1493-1	S-1367-1-6	

WIRE TABLE

CONTRACT NO:

DESIGN: J.B. MITCHELL 8-16-74
GROUP: [Signature] 8-16-74
DRAWN: B. FROMAN 8-15-74
CHECK: J. YOUSEL 8-15-74
STRESS: [Signature] 8-17-74

PROJ: [Signature] 8-17-74
APPD: [Signature]
OTHER:

COMMERCIAL AIRCRAFT DIV.
CESSNA AIRCRAFT CO.
5800 E. PAWNEE
WICHITA, KANSAS

TITLE: **WIRING DIAGRAM - WING TIP STROBE LIGHT (OPT)**

SIZE: C
CODE IDENT. NO.: 71379
DWG NO.: 0470401

SCALE: NONE
150, A150, FA150
PAGE: 11.7

(SR 7900)(SR 7901)(SR 7902)

00-223-0905

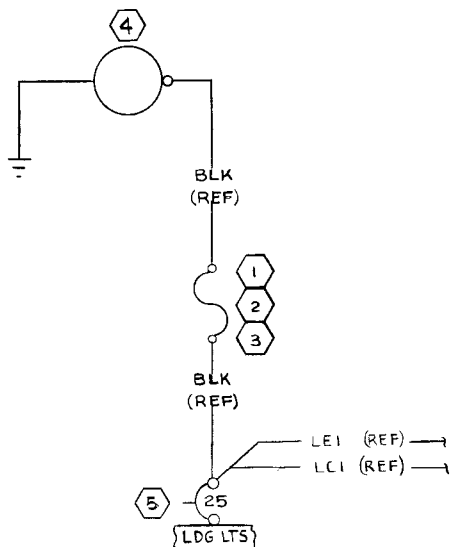

REVISION			
LET	DESCRIPTION	DATE	APPD
A	BY REV: DELETE HC2, 05130524-21, SFE-9, 155109A, DA3, WIRE LENGTHS; MOVED ALT BUS BAR TO CIRCUIT BREAKER; S-1367-2-8 WAS SOLDER (SR7900)(SR7901)(SR7902)(MER E0339)	CTH GS 9-13-74	[Signature] RF
B	BY REV: BLK (REF) WAS HCI: S-1360-25L WAS S-1360-10L SER(SR7900)(SR7901)(SR7902)	CTH BLA 10-23-74	[Signature] RF

5060-1-0905
CO-223-00

WIRE CODE NO.	GA	MATERIAL	LG	TERMINALS	SERIALS

ITEM NO.	PART NO.	DESCRIPTION
5	S-1360-25L	CIRCUIT BREAKER
4	0513052	LIGHTER ASSY
3	0513052	FUSE ASSY
2	SFE 9	FUSE
1	155109A	FUSEHOLDER

CONTRACT NO:			COMMERCIAL AIRCRAFT DIV. 5800 E. PAWNEE WICHITA, KANSAS	
DESIGN	J.B. MITCHELL	8-16-74	Cessna. AIRCRAFT CO.	
GROUP	[Signature]	8-16-74	TITLE	
DRAWN	B. FROMAN	8-15-74	WIRING DIAGRAM - CIGAR LIGHTER (OPT)	
CHECK	J. YUDEL	8-15-74	DWG NO 0470401	
STRESS	[Signature]	8-14-74	SIZE	C
PROJ			CODE IDENT NO.	71379
APPD			DWG NO	0470401
OTHER			SCALE:	NONE

CES-1000 IS APPLICABLE
VENDOR CODES PER S-1400
CES-XXX-CESSNA SPEC. NO.
S-XXX OR CMXXX-CESSNA
STD. NO.

SUPERSEDES:
0410011 PG 13.1.1

SUPERSEDED BY:

(SR7900)(SR7901)(SR7902) PAGE: 13.1

Change 3 20-59

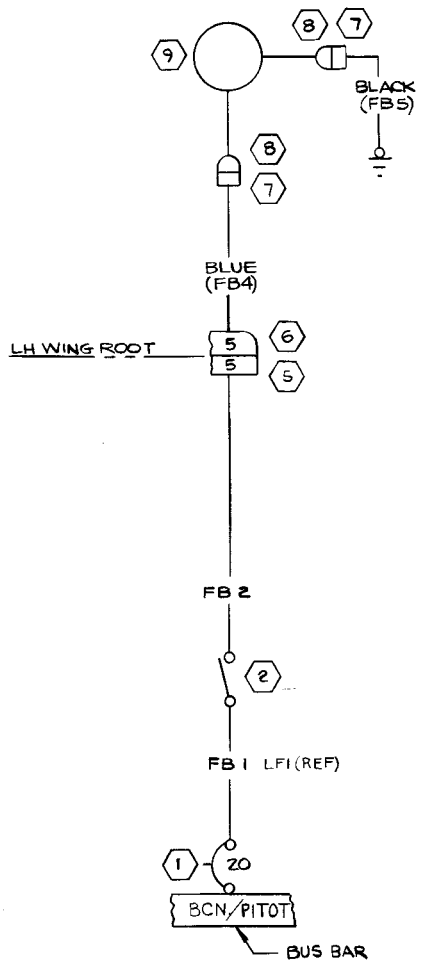

REVISION			
LET	DESCRIPTION	DATE	APPD
A	BY REV: DELETE S-1340-9, S-1341-9, FB3, WIRE LENGTH; BCN/PITOT WAS PITOT HT (MER E0339)	GS 9-13-74	<i>JM</i> <i>RF</i>
B	BY REV: S-1360-20L WAS S-1360-15L; FB1, FB2 + FB4/14 GA WIRE WAS 16 GA (SR8260)	BAH 5-13-75	<i>RF</i>

(15077006; ALSO 0610, F150010496 FA1500282)

00-223-0905

9	0721105-5	PITOT HEATER
8	S-1637-1	HOUSING-CAP
7	S-1637-2	HOUSING-PLUG
6	S-1640-6	HOUSING-PIN
5	S-1641-6	HOUSING-SOCKET

ITEM NO.	PART NO.	DESCRIPTION
2	S-2160-1	SWITCH
1	S-1360-20L	CKT BREAKER

CES-1000 IS APPLICABLE
VENDOR CODES PER S-1400
CES-XXXX-CESSNA SPEC. NO.
S-XXX OR CMXXXX-CESSNA
STD. NO.

SUPERSEDES:
0410011 PG 13.3
SUPERSEDED BY:

WIRE CODE NO.	GA	MATERIAL	LG	TERMINALS	SERIALS
BLACK (FB3)	18	-18-0		S-1636-1	S-1367-1-8
BLUE (FB4)	14	-16-6		S-1635-2	S-1636-2 (STD)
FB 2	14			S-1493-2	S-1636-2
FB 1	14			S-1493-2	S-1367-2-6

CONTRACT NO:			COMMERCIAL AIRCRAFT DIV. 5800 E. PAWNEE WICHITA, KANSAS		
DESIGN	J.B. MITCHELL	8-16-74	Cessna AIRCRAFT CO.		
GROUP	<i>J. Froman</i>	8-16-74	TITLE WIRING DIAGRAM - PITOT HEAT (OPT)		
DRAWN	B. FROMAN	8-15-74	SIZE	CODE IDENT. NO.	DWG NO
CHECK			C	71379	0470401
STRESS			SCALE: NONE	150, A150, FA150	PAGE: 13, 2
PROJ	<i>GR Zife</i>	8-19-74	(SR 7900)(SR 7901)(SR 7902)		
APPD					
OTHER					

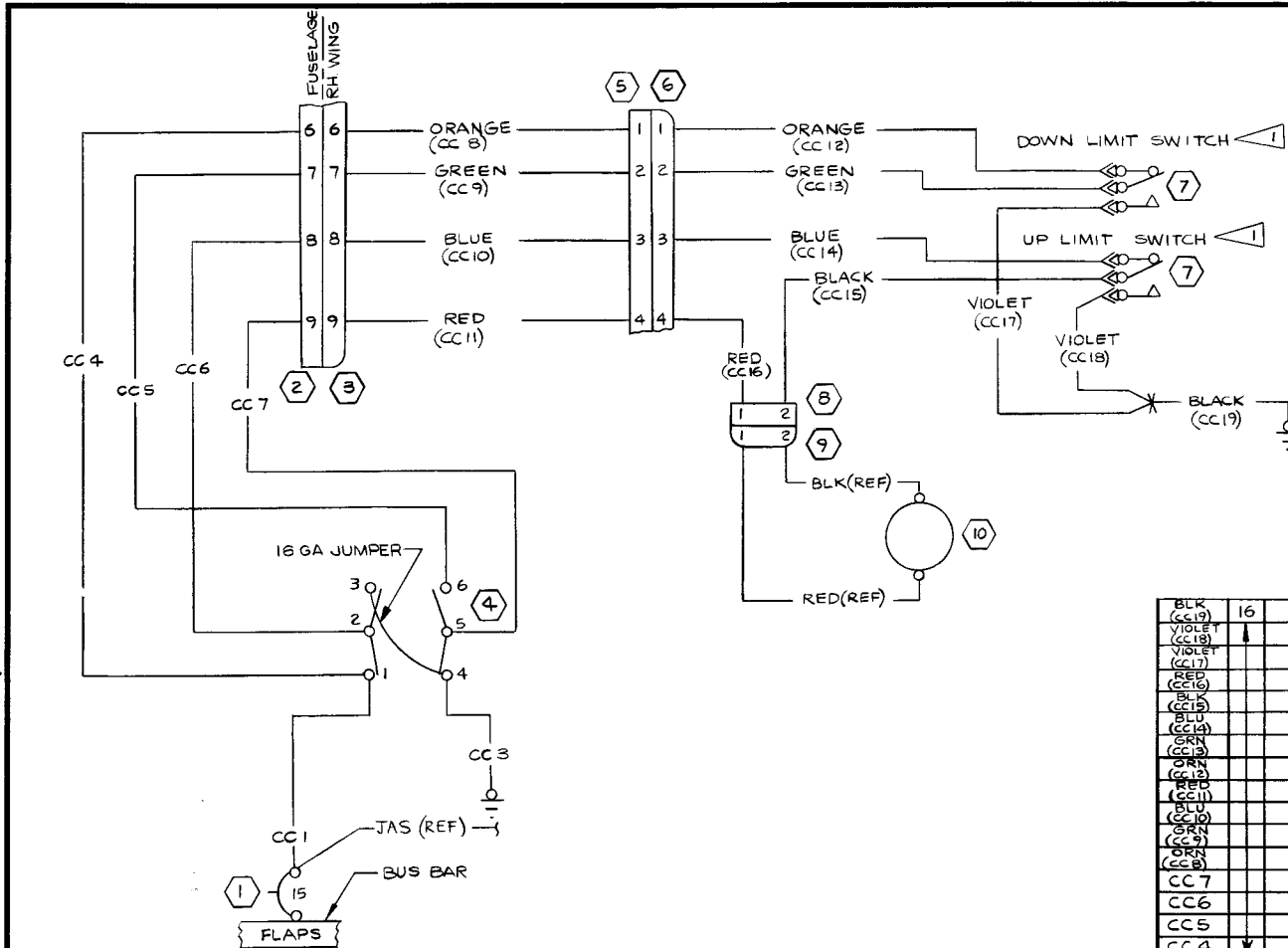

REVISION			
LET	DESCRIPTION	DATE	APPD
A	BY REV: DELETE S-1640-9, S-1641-9, CC2, WIRE LENGTHS; ADD JAF (REF); S-1637-2-6/CCI WAS S-1636-2 (MER E0339)	9-13-74	[Signature]
B	BY REV: ADD 16 GA JUMPER SER (SR7900)(SR7901)(SR7902)	10-14-74	[Signature]

WIRE CODE NO	GA	MATERIAL	LG	TERMINALS	SERIALS
BLK (CC 19)	16	-16-0		S-1370-2	S-1637-2-8
VIOLET (CC 18)		-16-7		S-1493-2	SEE BLK (CC 19)
VIOLET (CC 17)		-16-7		S-1493-2	SEE BLK (CC 19)
RED (CC 16)		-16-2		S-1635-2	S-1636-2
BLK (CC 15)		-16-0		S-1493-2	S-1636-2
BLU (CC 14)		-16-6			S-1635-2
GRN (CC 13)		-16-5			
RED (CC 12)		-16-3		S-1493-2	
RED (CC 11)		-16-2		S-1636-2	
BLU (CC 10)		-16-6			
GRN (CC 9)		-16-5			
GRN (CC 8)		-16-3		S-1636-2	S-1635-2
CC 7				S-1637-2-6	S-1636-2
CC 6					
CC 5					
CC 4					S-1636-2
CC 3	16			S-1637-2-6	S-1637-2-8
CC 1	16			S-1637-2-6	S-1370-2-6

NOTES:
 ▽ THESE SWITCHES ARE PART OF C301002-0101 ACTUATOR ASSY.

ITEM NO	PART NO.	DESCRIPTION
10	C301002-0101	ACTUATOR ASSY
9	S-1638-2	HOUSING - CAP
8	S-1638-1	HOUSING - PLUG
7	V3-1-D7	SWITCH
6	S-1640-6	HOUSING - PIN
5	S-1641-6	HOUSING - PLUG
4	S-1661-2	SWITCH
3	S-1640-9	HOUSING - PIN
2	S-1641-9	HOUSING - PLUG
1	S-1360-15L	CKT BREAKER

EQUIPMENT TABLE	
CES-1000 IS APPLICABLE VENDOR CODES PER S-1400 CES-XXXX-CESSNA SPEC. NO. S-XXX OR CMXXXX-CESSNA STD. NO.	SUPERSEDES: 0410011 PG 14.2.5 SUPERSEDED BY:

WIRE TABLE		
CONTRACT NO:		
DESIGN	J.B. MITCHELL	8-16-74
GROUP	S. J. [Signature]	8-16-74
DRAWN	B. FROMAN	8-15-74
CHECK	J. YOEUL	8-15-74
STRESS		
PROJ	[Signature]	8-17-74
APPD		
OTHER		
COMMERCIAL AIRCRAFT DIV. 5800 E. PAWNEE WICHITA, KANSAS		
TITLE WIRING DIAGRAM — WING FLAPS - ELECTRIC		
SIZE	C	71379
CODE IDENT. NO.		0470401
DWG NO		0470401
SCALE: NONE	150, A150, FA150	PAGE: 14, 1

(SR 7900)(SR 7901)(SR 7902)

Change 3 20-61/(20-62 blank)

5060B23-00

This page intentionally left blank.