

**P&W
R985
WASP JR.
SERIES**

***AN-1, -3, -4, -6, -6B,
-10, -12, -12B, -14B, B3,
B4, AND B5 ENGINES***

**ILLUSTRATED
PARTS
CATALOG**

TABLE OF CONTENTS

<i>Section</i>	<i>Page Number</i>	<i>Section</i>	<i>Page Number</i>
I INTRODUCTION	1	Tachometer and Gun Drive	45
II GROUP ASSEMBLY PARTS LIST	5	Magneto Drive	46
Front Case	5	Vacuum Pump Drive	47
Main Crankcase	8	Fuel Pump Drive	47
Chankshaft and Connecting Rods	12	Gun Synchronizer – (Optional Equipment) ..	48
Cylinders, Pistons and Pistonings	17	Cylinder Priming System	50
Deflectors	22	Ignition System	50
Oil Sump	28	Magneto and Attaching Parts	56
Collector Case and Intake Pipes	30	Carburetor and Attaching Parts	57
Rear Case	36	III ALPHABETICAL PARTS LIST	61
Oil Pump and Pressure Relief Valve	41	IV NUMERICAL PARTS LIST	93
Starter Drive	44	V SERVICE TOOLS LIST	107
Generator Drive	44		

SECTION I INTRODUCTION

1. GENERAL.

a. This catalog lists and describes the parts for Wasp Junior Models R-985-AN-1, -3, -4, -6, -6B, -10, 12, 12B, -14B, B3, B4 & B5 Engines manufactured by Pratt and Whitney Aircraft, Division of United Aircraft Corporation, East Hartford 8, Connecticut, U.S.A., and is divided into five (5) sections as shown in the Table of Contents.

b. The Table of Contents at the front of the catalog shows the method of grouping the parts and the sequence of the groups.

c. The Group Assembly Parts List (Section II) consists of the complete engine divided into 21 main groups as shown in the Table of Contents. Each assembly listed is followed immediately by its component parts properly indented, thereunder, to show their relationship to the assembly. Component parts of the complete engine, which are not included in any assembly, but which are used in conjunction with, attach, or attach to a certain assembly, are listed either preceding the first detail or following the last detail of that assembly, and in line with the major assembly.

d. The quantities listed in the "Units per Assy" column of the Group Assembly Parts List are, in the case of assemblies, the total quantity used per engine at the location indicated, while the component parts indented under the assemblies are the quantity used per assembly. The quantities specified therefore, are not necessarily the total used per engine. Refer to the Numerical Parts List (Section IV) for the total quantities used per engine.

e. Part numbers are used exclusively to identify parts.

f. All dimensions shown herein are nominal. They are inserted to facilitate identification for ordering and are not to be construed as restrictive in inspection.

2. REPLACEMENT STUDS.

Where .004 inch OS studs are listed in the Group Assembly or Alphabetical Parts List Sections, they are used as the first replacement of the standard size studs originally installed in the engine.

3. FRONT AND REAR

The terms "front" and "rear" are determined by considering the propeller end of the engine as the front, and the anti-propeller end as the rear.

4. RIGHT AND LEFT.

The terms "right" and "left" in connection with parts listed in this catalog refer to the viewpoint from the rear of the engine.

5. CYLINDER NUMBERS.

Viewing the engine from the rear, cylinders are numbered consecutively in a clockwise direction around the engine starting with number one cylinder, which is the top cylinder.

6. ABBREVIATIONS.

The abbreviations used throughout this catalog are as follows:

<i>Abbreviation</i>	<i>Full Name</i>
&	and
dia	diameter
ft.	feet
ID	Inside Diameter
in.	inch (es)
lb.	pound
LH	Left Hand
m/m	millimeter
No.	Number (s)
NPT	National Pipe Thread
OD	Outside Diameter
PD	Pitch Diameter
pr	pair
P&W	Pratt & Whitney Aircraft Division of United Aircraft Corporation East Hartford 8, Connecticut, U.S.A.
thd	thread

7. SYMBOLS.

The symbols used throughout this catalog and their explanations are as follows:

- * Indicates a part not to be stocked or requisitioned as a detail part.
- † Indicates a part available in oversize and/or under-size.

INSTRUCTIONS FOR USE OF PARTS CATALOG

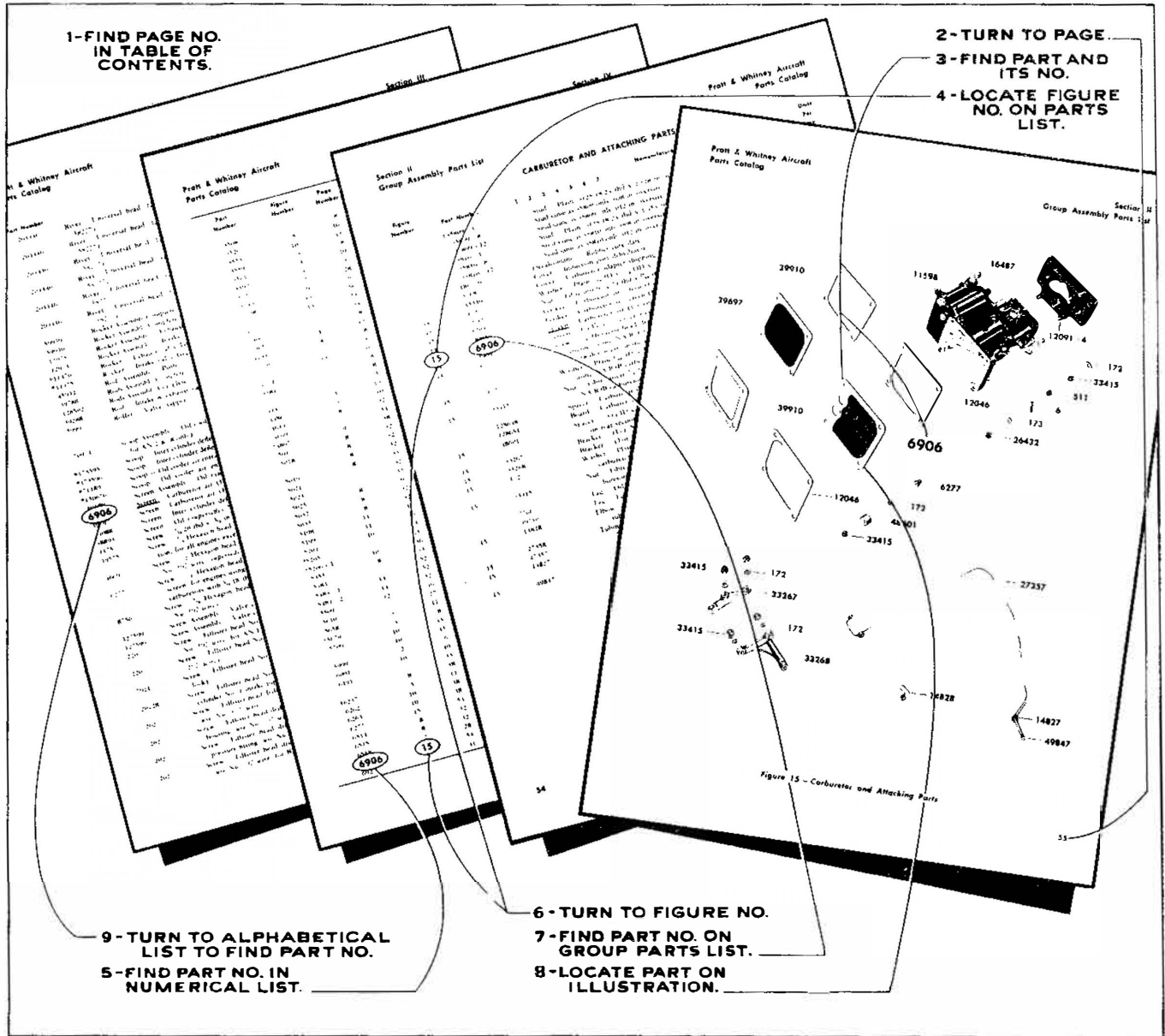

Figure 1

To secure part number when name and location in engine is known or to secure the part name and number where only the appearance of part and location is known:

- (1) Refer to Table of Contents to find page number on which the Major Assembly or system containing the part is shown.
- (2) Turn to the page where the Major Assembly is shown.
- (3) Find part and its part number on illustration.
- (4) Locate part number on Group Assembly Parts List page which will show part name.

To locate part name and location in engine when only part number is known:

- (5) Refer to Numerical Parts List to find part number.
- (6) Turn to page number in Group Assembly Parts List shown on Numerical Parts List for that part.
- (7) Find part number on Group Assembly Parts List page. This will show part name and figure number on which part is illustrated.
- (8) The illustration will show the location of that part on the engine.

To locate part number and location in engine when only part name is known:

- (9) Refer to Alphabetical Parts List to find part number.
- (6) Turn to page number in Group Assembly Parts List shown on Alphabetical Parts List for that part.
- (7) Find part number on Group Assembly Parts List page. This will show figure number on which part is illustrated.
- (8) The illustration will show location of that part on the engine.

SECTION II
GROUP ASSEMBLY PARTS LIST

FRONT CASE

Figure Number	Part Number	1	2	3	4	5	6	7	Nomenclature	Units Per Assy
2	39487								Case & Studs Assembly — Front (for all engines except B4)	1
	109722								Case & Studs Assembly — Front (for B4 only)	1
	*39485								Case — Front section (for all engines except B4)	1
	*109720								Case — Front section (for B4 only)	1
2	†42419+4								Stud — Plain $\frac{3}{8}$ -16-24 thd x $2\frac{3}{8}$ in. long (thrust cover; use (5) units for B4) .004 in. oversize	7
	42419+8								Stud same as 42419 only .008 in. oversize	
	42419+12								Stud same as 4249 only .012 in. oversize	
2	62								Dowel — Straight .250 dia x .625 in. long (thrust cover locating)	1
2	†37966								Liner — Thrust bearing	1
	37966+25								Liner same as 37966 only .025 in. oversize	
	109454								Bushing — .750 ID x 1.1895 OD x .965 in. long (front case; for B4 only)	1
	†77765+4								Stud — Drilled $\frac{3}{8}$ -16-24 thd x 3.060 in. long (thrust cover; for B4 only) .004 in. oversize	2
	77765+8								Stud same as 77765 only .008 in. oversize	
	77765+12								Stud same as 77765 only .012 in. oversize	
2	†12055+4								Stud — Plain $\frac{3}{16}$ -18-24 thd x 1.875 in. long (oil sump fastening; for all engines except B4) .004 in. oversize	2
	12055+8								Stud same as 12055 only .008 in. oversize	
	12055+12								Stud same as 12055 only .012 in. oversize	
	†90106+4								Stud — Plain $\frac{3}{16}$ -18-24 thd x 1.875 in. long (oil sump fastening; for B4 only) .004 in. oversize	2
	90106+8								Stud same as 90106 only .008 in. oversize	
2	†12088+4								Stud — Fitted $\frac{1}{4}$ -20-28 thd x $1\frac{1}{16}$ in. long (propeller regulator valve; for all engines except B4) .004 in. oversize	2
	12088+8								Stud same as 12088 only .008 in. oversize	
	12088+12								Stud same as 12088 only .012 in. oversize	
	†58843+4								Stud — Plain $\frac{3}{16}$ -18-24 thd x 1.42 in. long (propeller regulator valve; for B4 only) .004 in. oversize	2
	58843+8								Stud same as 58843 only .008 in. oversize	
2	†12089+4								Stud — Plain $\frac{1}{4}$ -20-28 thd x 1.125 in. long (propeller regulator valve; for all engines except B4) .004 in. oversize	2
	12089+8								Stud same as 12089 only .008 in. oversize	
	12089+12								Stud same as 12089 only .012 in. oversize	
	†28255+4								Stud — Plain $\frac{1}{4}$ -20-28 thd x 1.188 in. long (propeller regulator valve cover; for B4 only) .004 in. oversize	4
	28255+8								Stud same as 28255 only .008 in. oversize	
	28255+12								Stud same as 28255 only .012 in. oversize	
	109453								Bushing — Flanged .625 ID x .752 OD x .870 in. long (oil transfer tube; for B4 only)	1
	109461								Tube Assembly — Propeller shaft thrust bearing oil transfer (for B4 only)	1

FRONT CASE

Figure Number	Part Number	1	2	3	4	5	6	7	Nomenclature	Units Per Assy
2	†39493								Guide — Intake valve tappet upper (use (5) units on all engines except B4)	9
	39493+5								Guide same as 39493 only .005 in. oversize	
	39493+10								Guide same as 39493 only .010 in. oversize	
	39493+15								Guide same as 39493 only .015 in. oversize	
2	†39494								Guide — Intake valve tappet lower (for all engines except B4)	4
	39494+5								Guide same as 39494 only .005 in. oversize	
	39494+10								Guide same as 39494 only .010 in. oversize	
	39494+15								Guide same as 39494 only .015 in. oversize	
2	†39495								Guide — Exhaust valve tappet upper (use (5) units on all engines except B4)	9
	39495+5								Guide same as 39495 only .005 in. oversize	
	39495+10								Guide same as 39495 only .010 in. oversize	
	39495+15								Guide same as 39495 only .015 in. oversize	
2	†39496								Guide — Exhaust valve tappet lower (for all engines except B4)	4
	39496+5								Guide same as 39496 only .005 in. oversize	
	39496+10								Guide same as 39496 only .010 in. oversize	
	39496+15								Guide same as 39496 only .015 in. oversize	
2	39489								Manifold Brazing Assembly — Rocker oil	1
2	10270								Pipe — Vertical propeller oil feed (for all engines except B4)	1
2	39304								Pipe — 1/4 ID x .312-314 OD x 1 1/16 in. long (propeller regulator valve oil feed)	1
	80984								Gasket — Propeller regulator valve cover (for B4 only)	1
	80983								Cover — Propeller regulator valve (for B4 only)	1
	40111								Valve Assembly Complete — Propeller regulator (for AN engines only)	1
2	19149								Shaft — Oil control valve (for AN engines only)	1
2	9667								Gasket — Oil control valve cover (for AN engines only)	1
2	19209								Cover — Oil control valve (for AN engines only)	1
2	15008								Packing — Hydro valve (for AN engines only)	1
2	8232								Nut — Hydro propeller operating shaft packing (for AN engines only)	1
2	57169								Lever — Propeller regulator valve (supersedes No. 40098 for AN engines)	1
2	44								Pin — Tapered .125 dia x .750 in. long (propeller regulator valve lever locking; for AN engines only)	1
2	9667								Gasket — Propeller governor oil pressure tube flange to front crankcase (for B3 & B5 only)	1
2	116576								Flange — Propeller governor oil pressure tube (for B3 & B5 only)	1
2	91341								Plug — .438 Square head x .375-18 Pipe x .796 in. long (propeller governor oil pressure tube flange hole; use No. AS 100029 wire; for B3 & B5 only)	1
2	12156								Washer — Plain 1 1/16 ID x 1 1/32 OD x 1/32 in. thick (propeller regulator valve cover; for all engines except B4)	4
2	12856								Nut — Fibre insert 1/4-28 thd x 3/16 in. thick (propeller regulator valve cover)	4
2	233								Gasket — 1.3825 ID x .125 OD x .094 in. thick (front crankcase breather plug)	1
2	20159								Plug — 1.000 Hexagon head x 1 3/8-12 thd x 2 3/32 in. long (front crankcase breather; for all engines except B4; use No. AS 100029 wire)	1
	77766								Pipe Assembly — Breather (for B4 only)	1
	77761								Body — Breather connection (for B4 only)	1
	35932								Gasket — 1.281 ID x 1.500 OD x .031 in. thick (body breather connection; for B4 only)	1
	38353								Connection — Breather exhaust (for B4 only)	1
	13700								Bolt — 7/16 Hexagon head drilled x 1/4-28 thd x 1 1/32 in. long (connection breather exhaust; for B4 only)	1
	171								Washer — Plain 1 1/16 ID x 1/2 OD x 1/16 in. thick (connection breather exhaust screw; for B4 only)	1
2	39490								Screw — Rocker oil manifold (use No. AS 100029 wire)	9
2	39491								Screw — Rocker oil manifold (use No. AS 100029 wire)	9
2	45943								Tappet Assembly — Valve	18
	*39492								Tappet — Valve	1
2	33784								Socket — Pushrod ball	1
2	5999								Roller — Valve tappet	18
2	1044								Pin — Roller .3125 dia x .781 in. long (valve tappet roller)	18

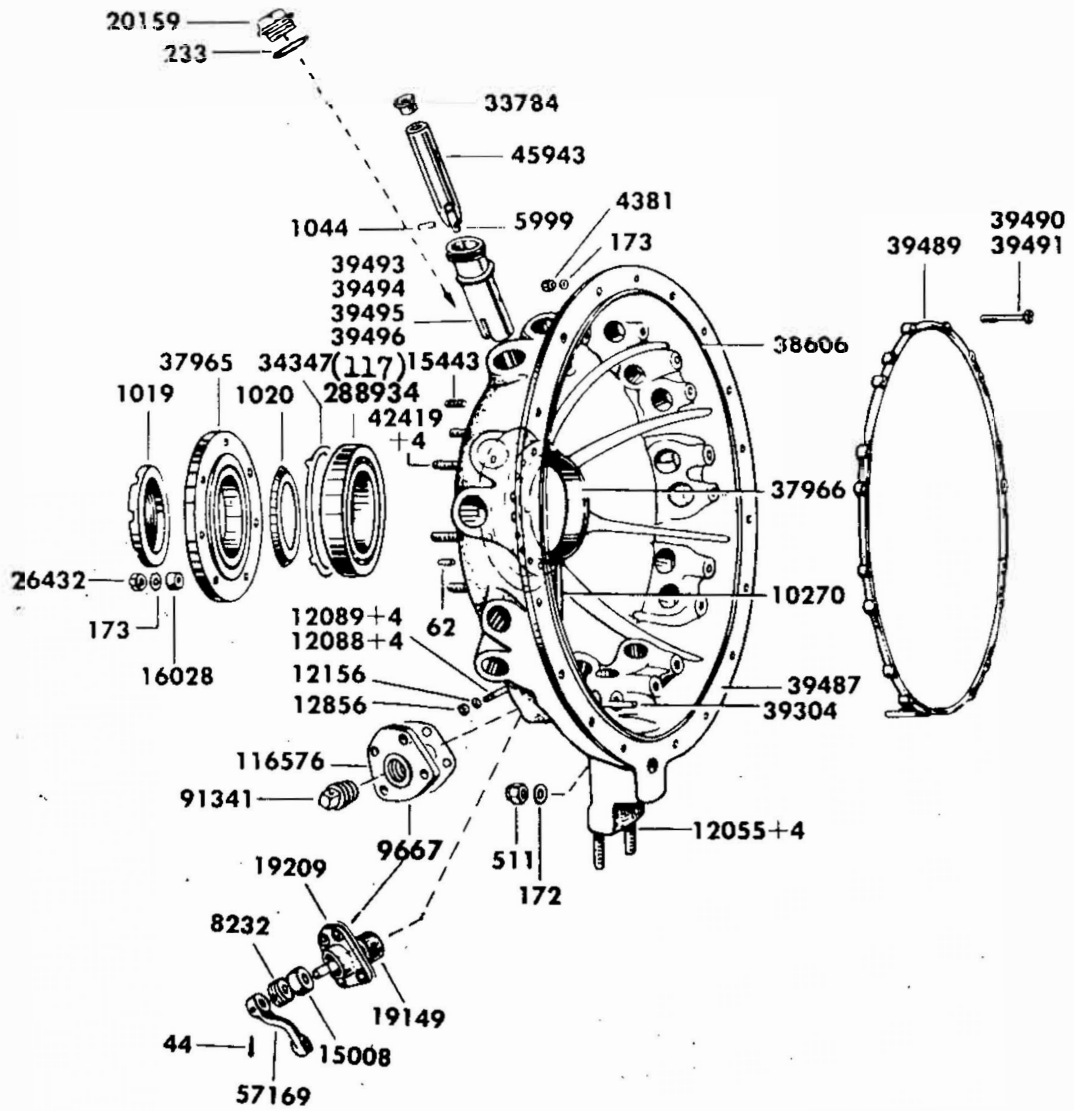

Figure 2. Front Case

FRONT CASE

Figure Number	Part Number	Nomenclature							Units Per Assy
		1	2	3	4	5	6	7	
	39710	Screw — Fillister head drilled 1/4-20 thd x 3/8 in. long (for engines having crankcase with tapped holes in front of the valve tappet guide bosses & opposing holes in the valve tappet guides)							18
2	38606	Seal — 16.625 ID x .125 in. dia Round (nose housing to main crankcase; <i>supersedes No. 12584</i>)							1
2	173	Washer — Plain 29/64 ID x 11/16 OD x 1/16 in. thick (nose section to main crankcase studs)							17
2	4381	Nut — Plain 9/16 Hexagon head x 3/8-24 thd x 21/64 in. thick (for use with Part No. 38300 cowl stud)							6
2	26432	Nut — Fibre insert 3/8-24 thd x 29/64 in. thick (nose section to main crankcase studs)							17
2	172	Washer — Plain 21/64 ID x 9/16 OD x 1/16 in. thick (nose section to Part No. 42422 main crankcase stud)							1
	12009	Nut — Plain 1/2 Hexagon head x 5/16-24 thd x 13/64 in. thick (nose section to Part No. 42422 main crankcase stud)							1
	818	Palnut — .500 in. Hexagon head x .3125-24 PD (nose section to Part No. 42422 main crankcase stud)							1
2	172	Washer — Plain 21/64 ID x 9/16 OD x 1/16 in. thick (main crankcase to nose housing long stud)							1
2	511	Nut — Castled 1/2 Hexagon head x 5/16-24 thd x 21/64 in. thick (main crankcase to nose housing long stud; <i>use No. AS 100029 wire</i>)							1
2	288934	Bearing Option — Propeller thrust (procurement number consists of: Part No. 117 Bearing — Ball 3.1496 ID x 5.518 OD x 1.0236 in. long (optional to Part No. 288902); Part No. 288902 Bearing — Ball 3.1496 ID x 5.518 OD x 1.0236 in. wide (optional to Part No. 117)							1
2	1020	Slinger — Propeller thrust bearing oil							1
2	1019	Spannernut — 23/4-12 PD x 3.600 x 1/2 in. thick (propeller thrust bearing)							1
2	34347	Ring — Propeller thrust bearing spacer							1
2	37965	Cover — Thrust bearing							1
2	16028	Spacer — .391 ID x .688 OD x .312 in. thick (thrust cover)							7
2	173	Washer — Plain 25/64 ID x 11/16 OD x 1/16 in. thick (propeller thrust cover nuts)							7
2	26432	Nut — Fibre insert 3/8-24 thd x 29/64 in. thick (propeller thrust cover)							7
	528	Nut — Castled 5/8 in. Hexagon head x 3/8-16 thd (thrust cover stud; for B4 only)							2
2	†15443	Plug — Plain slotted 5/16-18 thd x 1/4 in. long (optional cowl attaching holes in nose housing)							4
	15443+4	Plug same as 15443 only .004 in. oversize							
	18169	Spacer — .104 ID x .188 OD x .125 in. thick (data plate)							4
	35721	Plate — Engine data (for AN engines only)							1
	37100	Plate — Engine data (for B3 & B5 only)							1
	156	Rivet — Round head .0937 dia x 23/32 in. long (plate data)							4
	179	Washer — 3/32 ID x 1/4 OD x 1/32 in. thick (plate data)							4
	74955	Pipe Assembly — Front case to rear (for B4 only)							1
	74945	Gasket — Pipe front case to rear (for B4 only)							1
	33415	Nut — Fibre insert 5/16-24 thd x 23/64 in. thick (front case to rear pipe flange; for B4 only)							2

MAIN CRANKCASE

Figure Number	Part Number	Nomenclature							Units Per Assy
		1	2	3	4	5	6	7	
3	16475	Crankcase Assembly — Main (for all engines except B4)							1
	80806	Crankcase Assembly — Main (for B4 only)							1
	*13715	Crankcase Machining Assembly — Main (for all engines except B4)							1
	*80805	Crankcase Machining Assembly — Main (for B4 only)							1
	*3508	Crankcase — Front main (for all engines except B4)							1
	*80804	Crankcase — Front main (for B4 only)							1

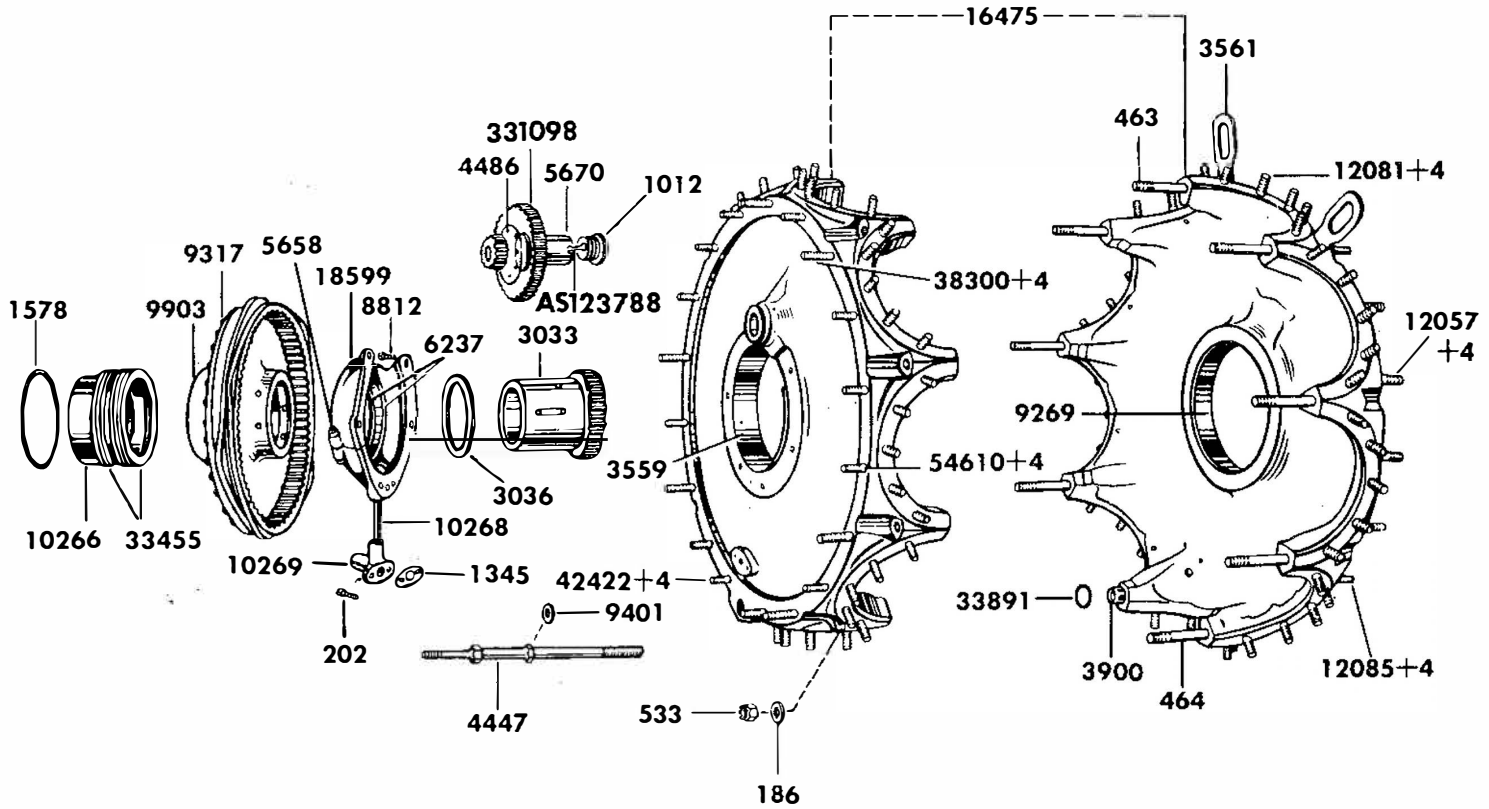

Figure 3. Main Crankcase

MAIN CRANKCASE

Figure Number	Part Number	1	2	3	4	5	6	7	Nomenclature	Units Per Assy
	*13645								Crankcase — Rear main (for all engines except B4)	1
	*74943								Crankcase — Rear main (for B4 only)	1
	†3559								Liner — Front main bearing 5.300 in. OD	1
	3559+3								Liner same as 3559 only .003 in. oversize OD	
	3559+5								Liner same as 3559 only .005 in. oversize OD	
	3559+10								Liner same as 3559 only .010 in. oversize OD	
	3559+20								Liner same as 3559 only .020 in. oversize OD	
3	†9269								Liner — Rear main bearing	1
	9269+3								Liner same as 9269 only .003 in. oversize	
	9269+4								Liner same as 9269 only .004 in. oversize	
	9269+5								Liner same as 9269 only .005 in. oversize	
	9269+10								Liner same as 9269 only .010 in. oversize	
	9269+20								Liner same as 9269 only .020 in. oversize	
	†27								Pin — Straight .1885-.1890 dia x .500 in. long (front & rear main bearing liners)	8
	27+6								Pin same as 27 only .006 in. oversize	
	27+11								Pin same as 27 only .011 in. oversize	
	3900								Ferrule — .594 ID x .6890 OD x 1.000 in. long (crankcase oil hole)	1
3	†5670								Bushing — Flanged .995 ID x 1.189 OD x 1.961 in. long (cam reduction gear)	1
	5670+3								Bushing same as 5670 only .003 in. oversize	
	5670+5								Bushing same as 5670 only .005 in. oversize	
	5670+10								Bushing same as 5670 only .010 in. oversize	
	†15								Pin — Straight .1285 dia x .406 in. long (cam reduction gear bushing)	1
	15+10								Pin same as 15 only .010 in. oversize	
	15+20								Pin same as 15 only .020 in. oversize	
	15+30								Pin same as 15 only .030 in. oversize	
3	†54610+4								Stud — Plain $\frac{3}{8}$ -16-24 thd x 1.75 in. long (main crankcase to nose housing; <i>supersedes</i> No. 15274) .004 in. oversize	11
	54610+8								Stud same as 54610 only .008 in. oversize	
	54610+12								Stud same as 54610 only .012 in. oversize	
3	†38300+4								Stud — Plain .375-16-24 thd x 2.156 in. long (main crankcase to nose section special cowl attaching) .004 in. oversize	6
	38300+8								Stud same as 38300 only .008 in. oversize	
	38300+12								Stud same as 38300 only .012 in. oversize	
3	†12081+4								Stud — Plain .375-16-24 thd x 1.562 in. long (cylinder flange) .004 in. oversize	90
	12081+8								Stud same as 12081 only .008 in. oversize	
	12081+12								Stud same as 12081 only .012 in. oversize	
	12081+16								Stud same as 12081 only .016 in. oversize	
	12081+62								Stud same as 12081 only .062 in. oversize	
	12081+66								Stud same as 12081 only .066 in. oversize	
	12081+70								Stud same as 12081 only .070 in. oversize	
	12081+74								Stud same as 12081 only .074 in. oversize	
3	†12085+4								Stud — Stepped .375-16 & .3125-24 thd & 1.625 in. long (oil sump attaching) .004 in. oversize	1
	12085+8								Stud same as 12085 only .008 in. oversize	
	12085+12								Stud same as 12085 only .012 in. oversize	
3	†42422+4								Stud — Stepped .375-16 & .3125-24 thd x 1.594 in. long (main crankcase to nose section) .004 in. oversize	1
	42422+8								Stud same as 42422 only .008 in. oversize	
	42422+12								Stud same as 42422 only .012 in. oversize	
3	†12057+4								Stud — Plain .375-16-24 thd x 1.938 in. long (main crankcase to blower) .004 in. oversize	17
	12057+8								Stud same as 12057 only .008 in. oversize	
	12057+12								Stud same as 12057 only .012 in. oversize	
	12057+62								Stud same as 12057 only .062 in. oversize	
	13652								Fitting — Main crankcase oil pressure	1
3	202								Screw — Fillister head drilled $\frac{1}{4}$ -20 thd $\frac{5}{16}$ in. long (main crankcase oil pressure fitting; use No. AS 100029 wire)	2

MAIN CRANKCASE

Figure Number	Part Number	1	2	3	4	5	6	7	Nomenclature	Units Per Assy
3	464								Bolt — Shouldered $\frac{3}{8}$ Hexagon head x $\frac{7}{16}$ -20 thd x $4\frac{11}{32}$ in. long (main crankcase halves; use (4) units for B4)	6
3	463								Bolt — Shouldered $\frac{3}{8}$ Hexagon head x $\frac{7}{16}$ -20 thd x $5\frac{1}{8}$ in. long (main crankcase halves & lifting links; use (2) units for all engines except B4)	4
3	3561								Link — Engine lifting (use (2) units for all engines except B4)	4
3	186								Washer — Plain $\frac{21}{64}$ ID x $\frac{7}{8}$ OD x $\frac{3}{32}$ in. thick (main crankcase bolts; use (12) units for B4)	14
3	533								Nut — Castle .4375-20 thd x .454 in. thick (main crankcase bolts)	8
3	9401								Washer — Plain .4531 ID x .802 OD x .093 in. thick (main crankcase stud)	1
3	4447								Stud — Double shouldered $\frac{7}{16}$ -24 & $\frac{5}{16}$ -24 thd x $9\frac{15}{32}$ in. long (main crankcase sections attaching to nose section)	1
3	331098								Gear Assembly — Cam reduction (supersedes No. 3965)	1
	*3447								Gear — Cam reduction small (use with Part No. 3965)	1
	*2987								Gear — Cam countershaft (use with Part No. 3965)	1
3	4486								Rivet — Round head $\frac{7}{32}$ dia x $\frac{3}{8}$ in. long (cam reduction gear; use (6) units for gears with (6) holes)	6
3	1012								Nut — Cam reduction gear	1
3	AS 123788								Cotterpin — .086-.090 dia x .500 in. long (cam reduction gear nut; <i>supersedes No. 7916 or 73127</i>)	1
	83323								Cotterpin — .100-.105 dia x .625 in. long (main crankcase bolt nut)	9
3	33891								Seal — .656 ID x .094 in. thick (main crankcase halves around Part No. 4447 stud)	1
	81186								Gear & Ring Assembly — Cam Drive	1
3	†3033								Gear — Cam drive	1
	3033+3								Gear same as 3033 only .003 in. oversize	
3	3036								Ring — Cam drive gear	1
3	1345								Gasket — .469 ID Pipe flanged x .031 in. thick (blower oil pressure pipe bracket)	1
	81188								Bracket & Pipe Assembly — Oil feed rear	1
	18600								Bracket Assembly — Oil feed rear	1
3	18599								Bracket Assembly — Oil feed	1
	*18016								Bracket — Oil feed	1
3	5658								Bolt — Drilled $\frac{7}{16}$ Hexagon head x $\frac{1}{4}$ -28 thd x $1\frac{15}{16}$ in. long (oil feed bracket)	2
	171								Washer — Plain $\frac{17}{64}$ ID x $\frac{1}{2}$ OD x $\frac{1}{16}$ in. thick (oil feed bracket)	2
	502								Nut — Castled $\frac{7}{16}$ Hexagon head x $\frac{1}{4}$ -28 thd x $\frac{9}{32}$ in. thick (oil feed bracket bolts)	2
	7916								Cotterpin — .072-.076 dia x .500 in. long (oil feed bracket bolt nuts)	2
3	†6237								Ring — Oil seal — Oil feed bracket	2
	6237—5								Ring same as 6237 only .005 in. undersize	
	6237—10								Ring same as 6237 only .010 in. undersize	
3	10269								Bracket — Blower oil pressure pipe	1
3	10268								Pipe — Oil feed upper	1
3	202								Screw — Fillister head drilled $\frac{1}{4}$ -20 thd x $\frac{9}{16}$ in. long (oil pressure pipe bracket; <i>use No. AS100029 wire</i>)	2
3	8812								Screw — Fillister head drilled $\frac{5}{16}$ -18 thd x $1\frac{5}{16}$ in. long (oil feed bracket; <i>use No. AS100029 wire</i>)	6
3	9903								Cam Assembly	1
	*7590								Cam	1
	*1943								Drum — Cam	1
3	9317								Rivet — Round head .157 dia x $1\frac{7}{16}$ in. long (cam assembly)	35
	81189								Spacer Assembly — Crankshaft thrust bearing (for all engines except B4)	1
	110019								Spacer Assembly — Crankshaft thrust bearing (for B4 only)	1
3	10266								Spacer — Crankshaft thrust bearing	1
3	†33455								Ring — Oil seal 3.607 ID x 3.750 OD x .1845 in. thick (crankshaft thrust bearing spacer; use (1) unit for B4)	2

MAIN CRANKCASE

Figure Number	Part Number	1	2	3	4	5	6	7	Nomenclature	Units Per Assy
	33455+5								Ring same as 33455 only .005 in. oversize	
	33455+10								Ring same as 33455 only .010 in. oversize	
	33455+10W								Ring same as 33455 only .010 in. oversize Width	
	33455+20								Ring same as 33455 only .020 in. oversize	
	33455+20W								Ring same as 33455 only .020 in. oversize Width	
	33455R1								Ring same as 33455 only .010 in. oversize on OD and .010 in. oversize on Width	
	33455R2								Ring same as 33455 only .010 in. oversize on OD and .020 in. oversize on Width	
	33455R3								Ring same as 33455 only .020 in. oversize on OD and .010 in. oversize on Width	
	33455R4								Ring same as 33455 only .020 in. oversize on OD and .020 in. oversize on Width	
3	†1578								Spacer — Crankshaft adjusting	1
	1578+35								Spacer same as 1578 only .035 in. oversize	

CRANKSHAFT AND CONNECTING RODS

Figure Number	Part Number	1	2	3	4	5	6	7	Nomenclature	Units Per Assy
4	261280								Crankshaft Balancing Assembly With Plugs — For AN-14B, B3, & B5 engines with 1 ³ / ₄ -16 N-3 in. crankshaft distributor valve thread (replaces No. 42087 crankshaft assembly with 1 ³ / ₁₆ -16 N-3 in. crankshaft distributor valve thread; supersedes No. 39892)	1
	261281								Crankshaft Balancing Assembly With Plugs — For B4 only (supersedes No. 80986 or 261296)	1
	*261279								Crankshaft — Front (for AN-14B, B3, & B5 only; contained in Part No. 39892 crankshaft assembly; replaces No. 40350; supersedes No. 39581)	1
	*261278								Crankshaft — Front (for B4 only; supersedes No. 46553)	1
4	36553								Cap — No. 30 (propeller shaft thread; for AN-14B, B3, & B5 only)	1
4	91745								Cap — No. 30 (propeller shaft thread; for all engines except AN-14B, B3 & B5)	1
	*34467								Counterweight — Front outer (supersedes No. 39917)	1
	*34466								Counterweight — Front inner (supersedes No. 39916)	1
	713								Rivet — .7485 dia x 1.210 in. long (counterweight)	1
	747								Rivet — .7485 dia x 1.798 in. long (counterweight long)	3
	749								Rivet — .9985 dia x 1.798 in. long (counterweight large diameter)	2
	*23834								Crankshaft — Rear	1
	*39915								Counterweight — Rear	1
4	34461								Liner — Flyweight	2
4	34462								Flyweight — Outer	1
4	34463								Flyweight — Outer	1
4	34465								Flyweight — Inner	1
4	34464								Flyweight — Inner	1
4	23902								Screw — Flyweight	2
4	44718								Expander — Flyweight screw	2
	167								Rivet — .7485 dia x 1.305 in. long (counterweight short)	3
	23922								Jet — Crankshaft oil	1
4	23904								Bolt — 1 ¹ / ₈ Hexagon head x 3/4-16 thd x 5 ¹³ / ₁₆ in. long (crankshaft)	1
4	22374								Screw — Flat fillister head No. 10-32 thd x 9/32 in. long (spline locating)	1
4	†44078								Plug — Crankshaft (for all engines except AN-14B, B3 & B5)	1
	44078+30								Plug same as 44078 only .030 in. oversize	
4	39570								Plug — Crankshaft (for AN-14B, B3 & B5 only; contained in Part No. 39892 crankshaft assembly)	1
	39571								Pin — Straight .185 dia x 2.844 in. long (crankshaft plug; for AN-14B, B3 & B5 only; contained in Part No. 39892 crankshaft assembly)	1
	10262								Pipe — Crankshaft (for all engines except AN-14B, B3, B4 & B5)	1

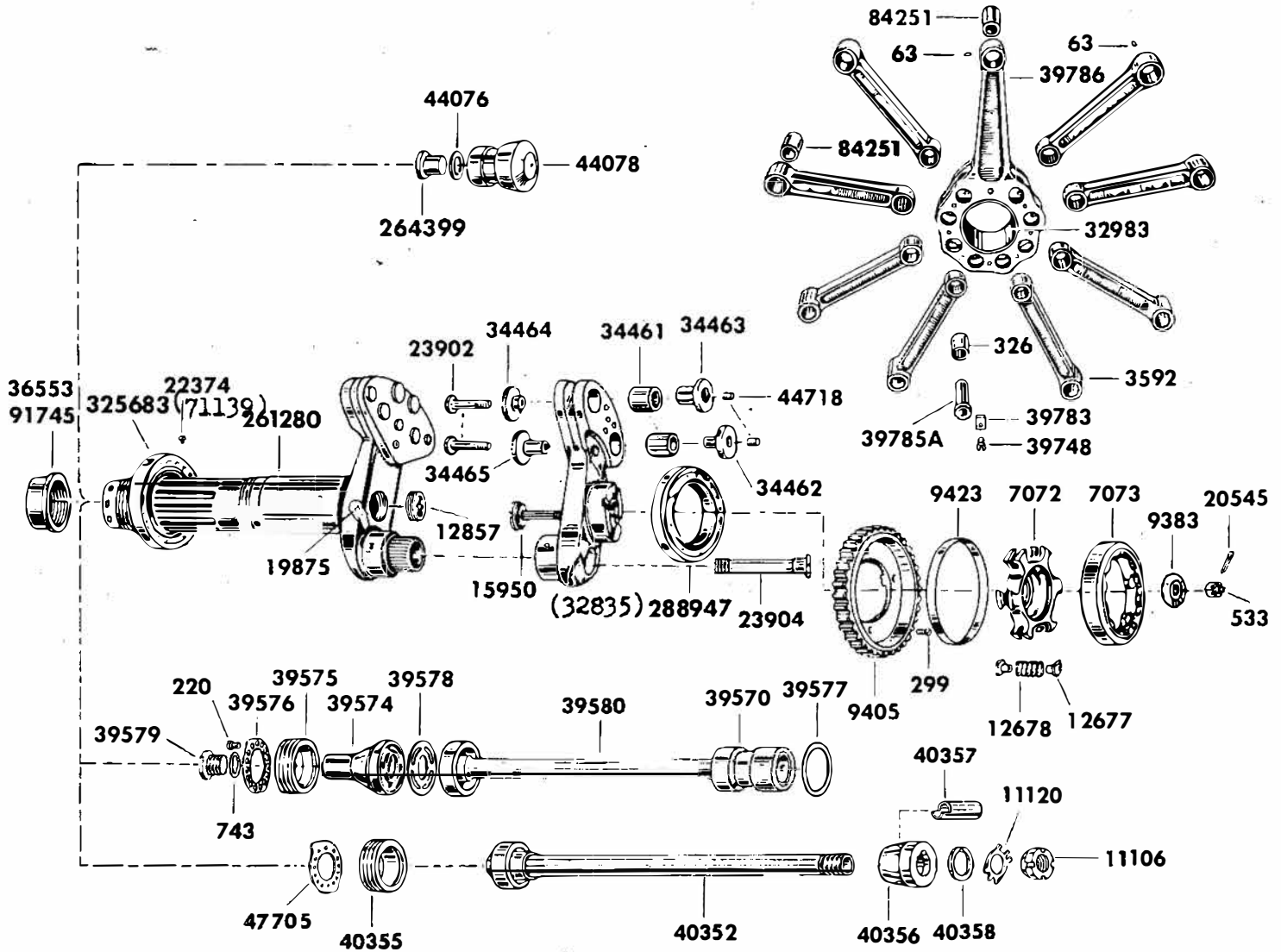

Figure 4. Crankshaft and Connecting Rods

CRANKSHAFT AND CONNECTING RODS

Figure Number	Part Number	1	2	3	4	5	6	7	Nomenclature	Units Per Assy
	10262								Pipe — Crankshaft (for B4 only; supersedes No. 80985)	1
4	44076								Seal — .438 ID x .125 in. thick (front crankshaft plug; for all engines except AN-14B, B3 & B5)	1
4	264399								Plug — Socket head .625-18 thd x .750 in. long (crankshaft plug; supersedes No. 44075; for all engines except AN-14B, B3 & B5)	1
4	12857								Plug — 1 $\frac{3}{4}$ -12 thd x $\frac{1}{2}$ in. long — No. 60 Drill (crankshaft inner)	1
	46								Pin — .191 dia x .500 in. long — No. 60 Drill (crankshaft rear)	1
4	19875								Pipe — Crankshaft	1
4	39580								Pipe Assembly — Crankshaft (for AN-14B, B3 & B5 only; contained in Part No. 39892 crankshaft assembly)	1
4	40352								Pipe Assembly — Crankshaft (for AN-14B, B3 & B5 only; contained in Part No. 42087 crankshaft assembly)	1
4	40356								Support — Crankshaft oil pressure pipe rear (contained in Part No. 42087 crankshaft assembly)	1
4	40357								Tube — Crankshaft oil pressure (contained in Part No. 42087 crankshaft assembly)	2
4	40358								Washer — Plain 1 $\frac{3}{16}$ ID x 1 $\frac{1}{8}$ OD x $\frac{1}{16}$ in. thick (crankshaft oil pressure pipe rear nut; contained in Part No. 42087 crankshaft assembly)	1
4	11120								Tabwasher — .719 ID x .938 OD x .058 in. thick (crankshaft oil pressure pipe rear nut; contained in Part No. 42087 crankshaft assembly)	1
4	11106								Nut — Spanner 1 $\frac{1}{16}$ -16 PD x 1 $\frac{3}{16}$ x $\frac{3}{16}$ in. thick (crankshaft oil pressure pipe rear; contained in Part No. 42087 crankshaft assembly)	1
4	39577								Gasket — 1.469 ID x 1.672 OD x .063 in. thick (crankshaft plug inner; for AN-14B, B3 & B5 only)	1
4	39578								Gasket — Crankshaft plug outer (for AN-14B, B3 & B5 only)	1
4	39574								Plug — Crankshaft front (for AN-14B, B3 & B5 only)	1
4	39579								Plug — .750 Hexagon head x .500-20 NF thd x .688 in. long (crankshaft front plug; for AN-14B, B3 & B5 only)	1
4	743								Gasket — .516 ID x .688 OD x .078 in. thick (crankshaft front plug; for AN-14B, B3 & B5 only)	1
4	39575								Nut — Crankshaft front plug (for AN-14B, B3 & B5 only; contained in Part No. 39892 crankshaft assembly)	1
4	40355								Nut — Crankshaft front plug (for AN-14B, B3 & B5 only; contained in Part No. 42087 crankshaft assembly)	1
4	39576								Washer — Crankshaft front plug (for AN-14B, B3 & B5 only; contained in Part No. 39892 crankshaft assembly)	1
4	47705								Washer — Crankshaft front plug (for AN-14B, B3 & B5 only; contained in Part No. 42087 crankshaft assembly)	1
	12228								Washer — Plain 1 $\frac{1}{16}$ ID x 1 $\frac{1}{16}$ OD x $\frac{1}{32}$ in. thick (crankshaft front plug; for AN-14B, B3 & B5 only)	3
4	220								Screw — Fillister head No. 8-32 thd x $\frac{1}{4}$ in. long (crankshaft front plug; use No. AS100029 wire; for AN-14B, B3 & B5 only)	3
	207098								Plug — Crankshaft front (for AN-14B, B3 & B5; for use in place of Part No. 39574 plug when any interference is encountered at installation)	1
4	20546								Cotterpin — .068-.090 dia x .875 in. long (locks crankshaft bolt; supersedes No. 8)	1
4	288947								Bearing Option — Crankshaft rear main (supersedes No. 10782; procurement number consists of: Part No. 32835 Bearing — Roller 3.1488 ID x 5.518 OD x 1.0236 in. long (optional to Part No. 288914 or 359238) Part No. 288914 Bearing — Roller 3.1488 ID x 5.518 OD x 1.0236 in Wide (optional to Part No. 32835 or 359238) Part No. 359238 Bearing — Roller 3.1488 ID x 5.518 OD x 1.0236 in Wide (optional to Part No. 32835 or 288914)	1
4	9405								Gear — Crankshaft rear	1
4	299								Screw — Flat head 2 $\frac{1}{16}$ -24 thd x $\frac{3}{4}$ in. long (crankshaft rear gear)	4
4	9423								Band — Blower spring drive friction	1
4	7073								Plate — Blower spring drive floating	1

CRANKSHAFT AND CONNECTING RODS

Figure Number	Part Number	Nomenclature	Units Per Assy
4	12677	Button — Blower spring drive	14
4	12678	Spring — Blower spring drive	7
4	7072	Plate — Blower spring drive fixed	1
4	15950	Bolt — Blower spring drive to crankshaft attaching	1
4	9383	Washer — Plain $2\frac{1}{4}$ ID x $1\frac{1}{16}$ OD x $\frac{1}{4}$ in. thick (blower spring drive bolt nut)	1
4	533	Nut — Castle .4375-20 thd x .454 in. thick (blower spring drive bolt)	1
4	20545	Cotterpin — .100-.105 dia x .750 in. long (blower spring drive bolt nut; <i>supersedes No. 11359</i>)	1
4	325683	Bearing Option — Front main (supersedes No. 10781; procurement number consists of: Part No. 71139 Bearing — Roller 2.9528 ID x 5.1181 OD x .9843 in. long (optional to Part No. 325682) Part No. 325682 Bearing — Roller 2.9528 ID x 5.1181 OD x .9843 in. Wide (optional to Part No. 71139)	1
	39788	Rods Assembly Complete — Connecting (for all engines except B4)	1
	128502	Rods Assembly Complete — Connecting (for B4 only)	1
	†39787	Masterod Assembly Complete — (for all engines except B4)	1
	39787—4	Masterod Assembly Complete same as 39787 only .004 in. undersize	
	39787—6	Masterod Assembly Complete same as 39787 only .006 in. undersize	
	128512	Masterod Assembly Complete — (for B4 only)	1
4	†39786	Masterod Bearing Assembly — (for all engines except B4)	1
	39786—2	Masterod Bearing Assembly same as 39786 only .002 in. undersize	
	39786—4	Masterod Bearing Assembly same as 39786 only .004 in. undersize	
	39786—6	Masterod Bearing Assembly same as 39786 only .006 in. undersize	
	128511	Masterod Assembly — (for B4 only)	1
	*39737	Masterod	1
4	84251	Bushing — Plain 1.375 ID x 1.5348 OD x 1.750 in. long (pistonpin; <i>supersedes No. 337</i>)	1
4	63	Dowel — Straight .163 dia x .203 in. long (pistonpin bushing)	1
4	†32983	Bearing — Masterod (for all engines except B4)	1
	32983—2	Bearing same as 32983 only .002 in. undersize	
	32983—4	Bearing same as 32983 only .004 in. undersize	
	32983—6	Bearing same as 32983 only .006 in. undersize	
	32983—8	Bearing same as 32983 only .008 in. undersize	
	32983—10	Bearing same as 32983 only .010 in. undersize	
	32983—12	Bearing same as 32983 only .012 in. undersize	
	32983—14	Bearing same as 32983 only .014 in. undersize	
	32983—16	Bearing same as 32983 only .016 in. undersize	
	32983—18	Bearing same as 32983 only .018 in. undersize	
	32983—20	Bearing same as 32983 only .020 in. undersize	
	32983+5	Bearing same as 32983 only .005 in. oversize	
	32983+5—2	Bearing same as 32983 only .005 in. oversize on OD & .002 in. undersize on ID	
	32983+5—4	Bearing same as 32983 only .005 in. oversize on OD & .004 in. undersize on ID	
	32983+5—6	Bearing same as 32983 only .005 in. oversize on OD & .006 in. undersize on ID	
	32983+5—8	Bearing same as 32983 only .005 in. oversize on OD & .008 in. undersize on ID	
	32983+5—10	Bearing same as 32983 only .005 in. oversize on OD & .010 in. undersize on ID	
	32983+5—12	Bearing same as 32983 only .005 in. oversize on OD & .012 in. undersize on ID	
	32983+5—14	Bearing same as 32983 only .005 in. oversize on OD & .014 in. undersize on ID	
	32983+5—16	Bearing same as 32983 only .005 in. oversize on OD & .016 in. undersize on ID	
	32983+5—18	Bearing same as 32983 only .005 in. oversize on OD & .018 in. undersize on ID	
	32983+5—20	Bearing same as 32983 only .005 in. oversize on OD & .020 in. undersize on ID	
	32983+10	Bearing same as 32983 only .010 in. oversize	
	32983+10—2	Bearing same as 32983 only .010 in. oversize on OD & .002 in. undersize on ID	
	32983+10—4	Bearing same as 32983 only .010 in. oversize on OD & .004 in. undersize on ID	
	32983+10—6	Bearing same as 32983 only .010 in. oversize on OD & .006 in. undersize on ID	
	32983+10—8	Bearing same as 32983 only .010 in. oversize on OD & .008 in. undersize on ID	
	32983+10—10	Bearing same as 32983 only .010 in. oversize on OD & .010 in. undersize on ID	

CRANKSHAFT AND CONNECTING RODS

Figure Number	Part Number	1	2	3	4	5	6	7	Nomenclature	Units Per Assy
	32983+10—12								Bearing same as 32983 only .010 in. oversize on OD & .012 in. undersize on ID	
	32983+10—14								Bearing same as 32983 only .010 in. oversize on OD & .014 in. undersize on ID	
	32983+10—16								Bearing same as 32983 only .010 in. oversize on OD & .016 in. undersize on ID	
	32983+10—18								Bearing same as 32983 only .010 in. oversize on OD & .018 in. undersize on ID	
	32983+10—20								Bearing same as 32983 only .010 in. oversize on OD & .020 in. undersize on ID	
	†128495								Bearing — Masterrod (<i>supersedes</i> No. 32983 for B4)	1
	128495—2								Bearing same as 128495 only .002 in. undersize	
	128495—4								Bearing same as 128495 only .004 in. undersize	
	128495—6								Bearing same as 128495 only .006 in. undersize	
	128495—8								Bearing same as 128495 only .008 in. undersize	
	128495—10								Bearing same as 128495 only .010 in. undersize	
	128495—12								Bearing same as 128495 only .012 in. undersize	
	128495—14								Bearing same as 128495 only .014 in. undersize	
	128495—16								Bearing same as 128495 only .016 in. undersize	
	128495—18								Bearing same as 128495 only .018 in. undersize	
	128495—20								Bearing same as 128495 only .020 in. undersize	
	128495+5								Bearing same as 128495 only .005 in. oversize	
	128495+5—2								Bearing same as 128495 only .005 in. oversize on OD & .002 in. undersize on ID	
	128495+5—4								Bearing same as 128495 only .005 in. oversize on OD & .004 in. undersize on ID	
	128495+5—6								Bearing same as 128495 only .005 in. oversize on OD & .006 in. undersize on ID	
	128495+5—8								Bearing same as 128495 only .005 in. oversize on OD & .008 in. undersize on ID	
	128495+5—10								Bearing same as 128495 only .005 in. oversize on OD & .010 in. undersize on ID	
	128495+5—12								Bearing same as 128495 only .005 in. oversize on OD & .012 in. undersize on ID	
	128495+5—14								Bearing same as 128495 only .005 in. oversize on OD & .014 in. undersize on ID	
	128495+5—16								Bearing same as 128495 only .005 in. oversize on OD & .016 in. undersize on ID	
	128495+5—18								Bearing same as 128495 only .005 in. oversize on OD & .018 in. undersize on ID	
	128495+5—20								Bearing same as 128495 only .005 in. oversize on OD & .020 in. undersize on ID	
	128495+10								Bearing same as 128495 only .010 in. oversize	
	128495+10—2								Bearing same as 128495 only .010 in. oversize on OD & .002 in. undersize on ID	
	128495+10—4								Bearing same as 128495 only .010 in. oversize on OD & .004 in. undersize on ID	
	128495+10—6								Bearing same as 128495 only .010 in. oversize on OD & .006 in. undersize on ID	
	128495+10—8								Bearing same as 128495 only .010 in. oversize on OD & .008 in. undersize on ID	
	128495+10—10								Bearing same as 128495 only .010 in. oversize on OD & .010 in. undersize on ID	
	128495+10—12								Bearing same as 128495 only .010 in. oversize on OD & .012 in. undersize on ID	
	128495+10—14								Bearing same as 128495 only .010 in. oversize on OD & .014 in. undersize on ID	
	128495+10—16								Bearing same as 128495 only .010 in. oversize on OD & .016 in. undersize on ID	
	128495+10—18								Bearing same as 128495 only .010 in. oversize on OD & .018 in. undersize on ID	
	128495+10—20								Bearing same as 128495 only .010 in. oversize on OD & .020 in. undersize on ID	
4	†39785A								Linkpin Assembly — 1.0594-1.0597 in. OD	8
	39785B								Linkpin Assembly 1.0597-1.0600 in. OD	
	39785C								Linkpin Assembly 1.0600-1.0603 in. OD	
	39785D+1								Linkpin Assembly 1.0603-1.0606 in. OD	
	39785E+1								Linkpin Assembly 1.0606-1.0609 in. OD	
	39785F+1								Linkpin Assembly 1.0609-1.0612 in. OD	
	39785A+5								Linkpin Assembly 1.0614-1.0617 in. OD	
	39785B+5								Linkpin Assembly 1.0617-1.0650 in. OD	
	39785C+5								Linkpin Assembly 1.0650-1.0653 in. OD	
	39785D+6								Linkpin Assembly 1.0653-1.0656 in. OD	
	39785E+6								Linkpin Assembly 1.0656-1.0659 in. OD	
	39785F+6								Linkpin Assembly 1.0659-1.0662 in. OD	
	39785A+10								Linkpin Assembly 1.0694-1.0697 in. OD	
	39785B+10								Linkpin Assembly 1.0697-1.0700 in. OD	
	39785C+10								Linkpin Assembly 1.0700-1.0703 in. OD	
	39785D+11								Linkpin Assembly 1.0703-1.0706 in. OD	
	39785E+11								Linkpin Assembly 1.0706-1.0709 in. OD	
	39785F+11								Linkpin Assembly 1.0709-1.0712 in. OD	
	*39782								Linkpin	1

CRANKSHAFT AND CONNECTING RODS

Figure Number	Part Number	1	2	3	4	5	6	7	Nomenclature	Units Per Assy
	39749								Plug — $\frac{3}{8}$ Hollow hexagon x $\frac{11}{16}$ -16 thd x $\frac{3}{8}$ in. long (linkpin)	1
4	39783								Lock — Linkpin	4
4	39748								Screw — Fillister head drilled $\frac{7}{16}$ -24 thd x $\frac{3}{8}$ in. long (linkpin)	8
4	3592								Linkrod Assembly	8
	*3469								Linkrod	1
4	326								Bushing — Plain 1.053 ID x 1.231 OD x 1.366 in. long (linkpin)	1
4	84251								Bushing — Plain 1.375 ID x 1.5348 OD x 1.750 in. long (pistonpin; <i>supersedes No. 337</i>)	1
4	63								Dowel — Straight .163 dia x .203 in. long (pistonpin bushing)	1
	93								Key — Flat $\frac{1}{4}$ x .140 x 1 in. long (locks cam drive gear)	1

CYLINDERS, PISTONS AND PISTONRINGS

Figure Number	Part Number	1	2	3	4	5	6	7	Nomenclature	Units Per Assy
	399353								Cylinder Assembly Complete — Cylinders No. 1, 2, 3, 4, 7, 8 & 9 (cylinders No. 4 & 7 for all engines: cylinders No. 1, 2, 3, 8 & 9 for B4 only; <i>supersedes No. 47555 or 126741</i>)	7
	399354								Cylinder Assembly Complete — Cylinders No. 1, 2, 3, 8 & 9 (<i>supersedes No. 70951 or 126742</i> for all engines except B4)	5
5	399355								Cylinder Assembly Complete — Cylinders No. 5 & 6 (<i>supersedes No. 47556 or 126834</i>)	2
	47518								Cylinder Machining & Studs Assembly — For all cylinders	1
	*39623								Head — Cylinder	1
	*47517								Barrel — Cylinder	1
5	†3500								Seat — Intake valve	1
	3500+5								Seat same as 3500 only .005 in. oversize	
	3500+10								Seat same as 3500 only .010 in. oversize	
	3500+20								Seat same as 3500 only .020 in. oversize	
5	†20786								Seat — Exhaust valve	1
	20786+5								Seat same as 20786 only .005 in. oversize	
	20786+10								Seat same as 20786 only .010 in. oversize	
5	†2108								Bushing — Valve rocker shaft outside	2
	2108+5								Bushing same as 2108 only .005 in. oversize	
5	†2943								Bushing — Flanged .6235 ID x .751 OD x .480 in. long (valve rocker shaft inside)	2
	2943+5								Bushing same as 2943 only .005 in. oversize	
5	†3496								Bushing — 18 m/m-1.5 m/m ID x 1.0811-1.0851 OD-16 Pitch left x $\frac{1}{2}$ in. long (sparkplug)	2
	3496+3								Bushing same as 3496 only .003 in. oversize	
	3496+5								Bushing same as 3496 only .005 in. oversize	
	3496+10								Bushing same as 3496 only .010 in. oversize	
	3496+15								Bushing same as 3496 only .015 in. oversize	
	3496+20								Bushing same as 3496 only .020 in. oversize	
	3496+30								Bushing same as 3496 only .030 in. oversize	
5	†3529								Guide — Intake valve	1
	3529+3								Guide same as 3529 only .003 in. oversize	
	3529+5								Guide same as 3529 only .005 in. oversize	
	3529+10								Guide same as 3529 only .010 in. oversize	
	3529+15								Guide same as 3529 only .015 in. oversize	
	3529+20								Guide same as 3529 only .020 in. oversize	
5	†39523								Guide — Exhaust valve	1
	39523+3								Guide same as 39523 only .003 in. oversize	
	39523+5								Guide same as 39523 only .005 in. oversize	

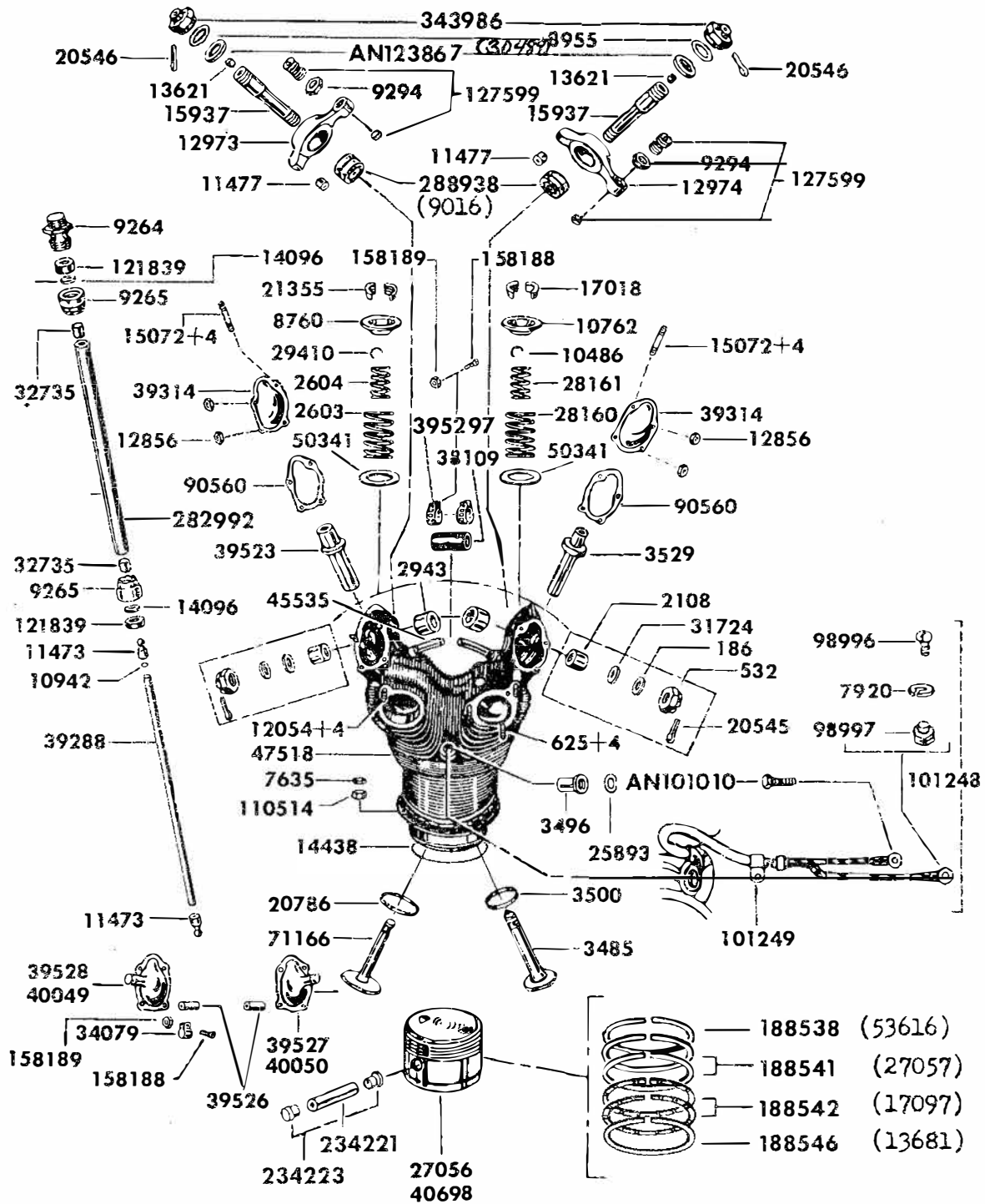

Figure 5. Cylinders, Pistons and Pistonrings
International AeroTech Academy For Training Purpose Only

CYLINDERS, PISTONS AND PISTONRINGS

Figure Number	Part Number	1	2	3	4	5	6	7	Nomenclature	Units Per Assy
	39523+10								Guide same as 39523 only .010 in. oversize	
	39523+20								Guide same as 39523 only .020 in. oversize	
	39523+30								Guide same as 39523 only .030 in. oversize	
	39523+40								Guide same as 39523 only .040 in. oversize	
5	†9264								Connector — Push rod cover	2
	9264+4								Connector same as 9264 only .004 in. oversize	
5	†625+4								Stud — Plain .3125-18-24 thd x 1.500 in. long (exhaust & intake flange) .004 in. oversize	5
	625+8								Stud same as 625 only .008 in. oversize	
	625+12								Stud same as 625 only .012 in. oversize	
	625+62								Stud same as 625 only .062 in. oversize	
5	†12054+4								Stud — Plain .3125-18-24 thd x 1.250 in. long (deflector fastening) .004 in. oversize	2
	12054+8								Stud same as 12054 only .008 in. oversize	
	12054+12								Stud same as 12054 only .012 in. oversize	
5	†15072+4								Stud — Plain .250-20-28 thd x 1.125 in. long (rockerbox cover) .004 in. oversize	8
	15072+8								Stud same as 15072 only .008 in. oversize	
	15072+12								Stud same as 15072 only .012 in. oversize	
5	3485								Valve — Intake	1
5	71166								Valve — Exhaust (<i>supersedes No. 14043</i>)	1
5	50341								Washer — 1.173 ID x 1.692 OD x .420 in. thick (valve spring lower; <i>supersedes No. 8759</i>)	2
5	28161								Spring — 1.600 OD x .154 in. dia Wire (intake valve inside)	1
5	28160								Spring — 1.683 ID x .183 in. dia Wire (intake valve outside)	1
5	2604								Spring — 1.600 OD x .162 in. dia Wire (exhaust valve inside)	1
5	2603								Spring — 1.683 ID x .192 in. dia Wire (exhaust valve outside)	1
5	10486								Circllet — Intake valve	1
5	29410								Lockring — .576 OD x .048 in. thick (exhaust valve)	1
5	10762								Washer — .658 ID x $1\frac{3}{16}$ OD x $\frac{9}{16}$ in. thick (intake valve spring upper)	1
5	8760								Washer — .883 ID x 1 OD x $\frac{9}{16}$ in. thick (exhaust valve spring upper)	1
5	17018								Lock — .616 in. dia x 15° (intake valve)	2
5	21355								Valvelock — Exhaust	2
5	12974								Rocker Assembly — Intake valve	1
	*11475								Rocker — Intake valve large bearing type	1
5	†11477								Cup — Pushrod ball rocker	1
	11477+1								Cup same as 11477 only .001 in. oversize	
	11477+2								Cup same as 11477 only .002 in. oversize	
	11477+4								Cup same as 11477 only .004 in. oversize	
5	12973								Rocker Assembly — Exhaust valve	1
	*11476								Rocker — Exhaust valve large bearing type	1
5	†11477								Cup — Pushrod ball rocker	1
	11477+1								Cup same as 11477 only .001 in. oversize	
	11477+2								Cup same as 11477 only .002 in. oversize	
	11477+4								Cup same as 11477 only .004 in. oversize	
5	127599								Screw Assembly — Valve clearance adjusting (<i>supersedes No. 9514</i>)	2
5	9294								Nut — Plain $\frac{3}{4}$ Hexagon head x $1\frac{9}{32}$ -24 thd x $\frac{5}{32}$ in. thick (valve adjusting screw lock)	2
5	288938								Bearing Option — Rocker arm (procurement number consist of: Part No. 9016 Bearing — Ball .4724 ID x 1.5748 OD x .9449 in. long (optional to Part No. 288906 or 359234) Part No. 288906 Bearing — Bali .4724 ID x 1.5748 OD x .9449 in. long (optional to Part No. 9016 or 359234) Part No. 359234 Bearing — Ball .4724 ID x 1.5748 OD x .9949 in. long (optional to Part No. 9016 or 288906)	2
5	15937								Shaft Assembly — Valve rocker (<i>supersedes No. 45937</i>)	2
	*40052								Shaft — Valve rocker	1
5	13621								Cork — Valve rocker shaft	1

CYLINDERS, PISTONS AND PISTONRINGS

Figure Number	Part Number	1	2	3	4	5	6	7	Nomenclature	Units Per Assy
5	8955								Gasket — .625 ID x .812 OD x .094 in. thick (valve rocker shaft; for use with Part No. 126741, 126742 or 126834)	2
	30489								Seal — .500 ID x .625 OD x .047 in. thick (valve rocker shaft; for use with Part No. 126741, 126742 or 126834)	2
5	AN123867								Packing — Preformed .612 ID x .103 in. thick (valve rocker shaft; for use with Part No. 399353, 399354 or 399355)	2
	16405								Nut — Valve rocker shaft (for use with Part No. 126741, 126742 or 126834)	2
5	343986								Nut — Valve rocker shaft (for use with Part No. 399353, 399354 or 399355)	2
5	20546								Cotterpin — .086-.090 dia x .875 in. long (valve rocker shaft nut)	2
5	31724								Seal — .375 ID x .080 in. thick (valve rocker shaft)	2
5	186								Washer — Plain $\frac{29}{64}$ ID x $\frac{7}{8}$ OD x $\frac{3}{32}$ in. thick (valve rocker shaft)	2
5	532								Nut — Castled $\frac{3}{4}$ Hexagon head x $\frac{7}{16}$ -20 thd x $1\frac{1}{32}$ in. thick (valve rocker shaft)	2
5	20545								Cotterpin — .100-.105 dia x .750 in. long (valve rocker shaft nut)	2
	134								Plug — Hexagon socket .375 in. ANPT (rockerbox cover: cylinders No. 1, 2, 3, 8 & 9; for all engines except B4)	2
5	†45535								Pipe Assembly — Inter ear oil drain (use on cylinders No. 4, 5, 6 & 7; for all engines except B4)	2
	45535+6								Pipe same as 45535 only .006 in. oversize	
5	38109								Hose — Inter ear oil drain pipe (use on cylinders No. 4, 5, 6 & 7; for all engines except B4)	1
	395296								Clamp — Assembly of, inter ear oil drain pipe hose (supersedes No. 38093; use on cylinders No. 4, 5, 6 & 7; for all engines except B4)	2
5	395297								Clamp — Hose (inter ear oil drain pipe)	1
5	158189								Nut — Fibre .190-24 thd x .266 in. thick Special (inter ear oil drain pipe hose clamp)	1
5	158188								Screw — Fillister head .190-24 x 1.000 in. long Special (inter ear oil drain pipe hose clamp)	1
	21027								Screw — Round head No. 10-32 thd x $\frac{3}{16}$ in. long (thermocouple holes)	1
	17346								Plug — .281 Square head x .125-27 Pipe x .578 in. long (primer holes on spare cylinders)	1
5	†27056								Piston — 6:1 (cylinders No. 1, 2, 3, 4, 7, 8 & 9)	1
	27056+10								Piston same as 27056 only .010 in. oversize	
	27056+20								Piston same as 27056 only .020 in. oversize	
5	†40698								Piston — 6:1 (cylinders No. 5 & 6)	1
	40698+10								Piston same as 40698 only .010 in. oversize	
	40698+20								Piston same as 40698 only .020 in. oversize	
5	†188538								Pistonring — Compression chrome plate (supersedes No. 53616)	1
	188538+2W								Pistonring same as 188538 only .002 in. oversize on Width	
	188538+10								Pistonring same as 188538 only .010 in. oversize	
	188538+10W								Pistonring same as 188538 only .010 in. oversize on Width	
	188538R1								Pistonring same as 188538 only .010 in. oversize on OD & .002 in. oversize on Width	
	188538R2								Pistonring same as 188538 only .010 in. oversize on OD & .010 in. oversize on Width	
	188538R3								Pistonring same as 188538 only .010 in. oversize on OD & .020 in. oversize on Width	
	188538+20								Pistonring same as 188538 only .020 in. oversize	
	188538+20W								Pistonring same as 188538 only .020 in. oversize on Width	
	188538R4								Pistonring same as 188538 only .020 in. oversize on OD & .002 in. oversize on Width	
	188538R5								Pistonring same as 188538 only .020 in. oversize on OD & .010 in. oversize on Width	
	188538R6								Pistonring same as 188538 only .020 in. oversize on OD & .020 in. oversize on Width	
5	†188541								Pistonring — Compression (supersedes No. 27057)	2
	188541+2W								Pistonring same as 188541 only .002 in. oversize on Width	
	188541+10								Pistonring same as 188541 only .010 in. oversize	
	188541+10W								Pistonring same as 188541 only .010 in. oversize on Width	
	188541+10+2W								Pistonring same as 188541 only .010 in. oversize on OD & .002 in. oversize on Width	
	188541+10+10W								Pistonring same as 188541 only .010 in. oversize on OD & .010 in. oversize on Width	
	188541+10+20W								Pistonring same as 188541 only .010 in. oversize on OD & .020 in. oversize on Width	
	188541+20								Pistonring same as 188541 only .020 in. oversize	

CYLINDERS, PISTONS AND PISTONRINGS

Figure Number	Part Number	1	2	3	4	5	6	7	Nomenclature	Units Per Assy
	188541+20W								Pistonring same as 188541 only .020 in. oversize on Width	
	188541+20+2W								Pistonring same as 188541 only .020 in. oversize on OD & .002 in. oversize on Width	
	188541+20+10W								Pistonring same as 188541 only .020 in. oversize on OD & .010 in. oversize on Width	
	188541+20+20W								Pistonring same as 188541 only .020 in. oversize on OD & .020 in. oversize on Width	
5	†188542								Pistonring — Dual oil control (<i>supersedes No. 17097</i>)	2
	188542+10								Pistonring same as 188542 only .010 in. oversize	
	188542+10W								Pistonring same as 188542 only .010 in. oversize on Width	
	188542+10+10W								Pistonring same as 188542 only .010 in. oversize on OD & .010 in. oversize on Width	
	188542+20								Pistonring same as 188542 only .020 in. oversize	
	188542+20+10W								Pistonring same as 188542 only .020 in. oversize on OD & .010 in. oversize on Width	
5	†188546								Pistonring — Scraper (<i>supersedes No. 13681</i>)	1
	188546+10								Pistonring same as 188546 only .010 in. oversize	
	188546+20								Pistonring same as 188546 only .020 in. oversize	
	392441								Decalcomania — Rubber assembly date	1
5	234221								Pistonpin Assembly — (<i>supersedes No. 31795</i>)	1
	*31740								Pistonpin	1
5	234223								Plug — Pistonpin (<i>supersedes No. 9002</i>)	2
5	90560								Gasket — Rockerbox cover (<i>supersedes No. 39315</i>)	18
5	39527								Cover — Intake rockerbox (use on cylinders No. 3, 4, 6 & 7; for all engines except B4)	9
5	39314								Cover — Intake & exhaust rockerbox (cylinders No. 1, 2 & 9; for all engines except B4; use (1) unit on cylinder No. 3 exhaust rockerbox & (1) unit on cylinder No. 8 intake rockerbox)	8
5	40050								Cover — Intake valve rocker (cylinder No. 5; for all engines except B4)	1
5	39528								Cover — Exhaust valve rockerbox (cylinders No. 4, 5, 7 & 8; for all engines except B4)	9
5	40049								Cover — Exhaust valve rockerbox (cylinder No. 6; for all engines except B4)	1
5	12856								Nut — Fibre insert 1/4-28 thd x 5/16 in. thick (rockerbox cover)	72
5	14438								Seal — 4.625 ID x .113 in. dia Round (cylinder barrel)	9
5	110514								Nut — Plain .556 Hexagon head x 3/4-24 thd x .375 in. thick (cylinder flange; <i>supersedes No. 10449</i>)	90
5	7635								Palnut — .562 in. Hexagon head x .375-24 PD (cylinder flange)	90
	45942								Rod Assembly — Push	18
5	39288								Rod — Intake & exhaust valve push	1
5	10942								Spacer — Plain 1/4 ID x .551 OD x .040 in. thick (pushrod; spares assemblies are shipped with (2) units)	1
5	11473								Ball — End — Pushrod	2
5	282992								Cover Assembly — Pushrod (<i>supersedes No. 39292</i>)	18
	*39287								Cover — Pushrod	1
5	†32735								Ferrule — .876 ID x .9380 OD x .844 in. long (pushrod cover)	2
	32735—10								Ferrule same as 32735 only .010 in. undersize	
	392441								Decalcomania — Rubber assembly date	1
5	121839								Packing — 1.005 ID x 1.285 OD x .400 in. thick (pushrod tube outer; <i>supersedes No. 88917</i>)	36
5	14096								Packing — 1.015 ID x 1.281 OD x .125 in. thick (pushrod tube inner; <i>supersedes No. 9282</i>)	36
5	9265								Nut — Upper & lower pushrod tube packing (<i>use No. AS100029 wire</i>)	36
	17346								Plug — .281 Square head x .125-27 Pipe x .578 in. long (unused primer holes; cylinders No. 4, 5, 6 & 7)	4
5	39526								Hose — Inter cylinder oil drain pipe connection (use (4) units for all engines except B4)	8
5	34079								Clamp Assembly — 1.125 in. ID Hose (inter cylinder oil drain hose; use (8) units for all engines except B4)	16
5	158188								Screw — Inter cylinder oil drain hose clamp	1
5	158189								Nut — Fibre .190-24 thd x .266 in. thick Special (inter cylinder oil drain hose clamp)	1
	103106								Thermocouple Assembly Complete — Sparkplug gasket type (optional equipment)	1
5	101248								Thermocouple Assembly	1
	*88135								Terminal Assembly — Thermocouple wire lock type	1

CYLINDERS, PISTONS AND PISTONRINGS

Figure Number	Part Number	1	2	3	4	5	6	7	Nomenclature	Units Per Assy
	*88136								Terminal — Thermocouple wire	1
5	98996								Screw — Round head No. 6-32 thd x .312 in. long (thermocouple wire terminal)	1
5	98997								Nut — Lock No. 6-32 thd (thermocouple wire terminal screw)	1
	*88136								Terminal — Thermocouple wire	1
5	101249								Clip — Thermocouple cylinder head	1
5	7920								Lockwasher — .194-205 ID x .337 OD x .047-.057 in. thick (thermocouple clip bolt; supersedes No. 188)	1
5	AN 101010								Bolt — .367-.376 Hexagon head x .190-32 NF-3A thd x .625 in. long (thermocouple clip; supersedes No. 41174)	1
5	25893								Gasket — .718 ID x .968 OD x .0808 in. thick (sparkplug)	18
	303758								Sparkplug — Rem 39N (optional to Part No. 137705, 128095 or 158365)	18
	128095								Sparkplug — BG-RB485S (optional procurement)	18
	137705								Sparkplug — Champion RC-26-S (optional procurement)	18
	158365								Sparkplug — BG-706SR (optional procurement)	18
	56433								Plug — Cylinder dehydrator	18

DEFLECTORS

Figure Number	Part Number	1	2	3	4	5	6	7	Nomenclature	Units Per Assy
	48610								Deflector Assembly Complete — (for B3 & B5 engines with magneto SB9RN)	1
	41461								Deflector Assembly Complete — (for all AN engines except AN-2 & -8; for B3 & B5 engines with magneto SB9RN-4)	1
6	76369								Deflector Assembly Complete — (supersedes No. 120670 for B4)	1
	39980								Deflector Assembly — Inter ear (for all cylinders)	9
	*39979								Body — Deflector inter ear	1
	39995								Brace Assembly — Inter ear deflector	1
	80328								Clip — Inter ear deflector tube	1
	74014								Tube — Inter ear deflector blast	1
	74026								Support — Inter ear deflector tube	1
	58329								Rivet — Brazier head .095 dia x .281 in. long (deflector)	2
	73996								Clip — Inter ear deflector tube	1
	58328								Rivet — Brazier head .095 dia x .218 in. long (deflector)	5
	58322								Rivet — Brazier head .126 dia x .310 in. long (deflector)	3
	73995								Rivet — Brazier head .189 dia x .468 in. long (deflector)	2
	58325								Rivet — Brazier head .126 dia x .562 in. long (deflector)	2
	57945								Rivet — Brazier head .095 dia x .250 in. long (deflector)	2
6	39982								Deflector Assembly — Inter cylinder (cylinders No. 1-2, 3-4, 4-5, 6-7, 7-8, 8-9 & 9-1 for B3 & B5 with magneto SB9RN — use (3) units for B3 & B5 engines with magneto SB9RN-4 & for all AN engines except AN-2 & -8 between cylinders No. 4-5, 6-7 & 9-1; use (4) units for B4 between cylinders No. 1-2, 3-4, 6-7 & 9-1)	7
	*39981								Deflector — Inter cylinder	1
	24883								Guide — Inter cylinder deflector	1
6	24884								Bolt — Latch — Inter cylinder deflector	2
6	14013								Spring — Deflector	1
	12012								Grommet — $\frac{5}{16}$ ID x $\frac{13}{16}$ OD x $\frac{5}{16}$ in. thick (inter ear deflector primer)	1
	23612								Nut — Anchor elastic stop $\frac{1}{4}$ -28 thd (deflector)	1
	151627								Strip — Inter cylinder deflector bearing left	1
	73988								Strip — Inter cylinder deflector bearing right	1
	74016								Strip — Inter cylinder deflector nose blank	1
	74013								Brace — Inter cylinder deflector large	1
	74012								Brace — Inter cylinder deflector small	1

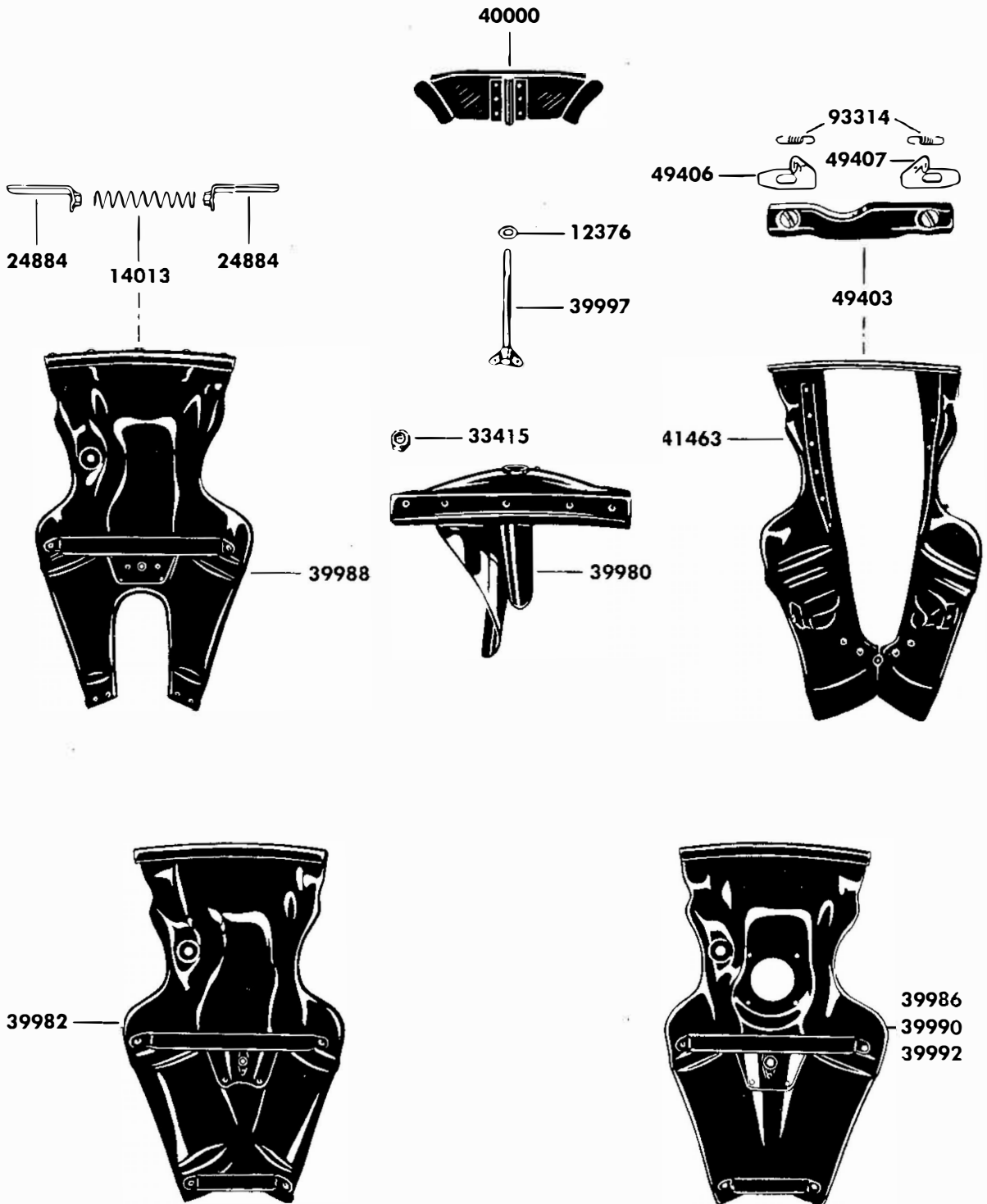

Figure 6. Deflectors
International AeroTech Academy For Training Purpose Only

DEFLECTORS

Figure Number	Part Number	1	2	3	4	5	6	7	Nomenclature	Units Per Assy
	73981								Plate — Inter cylinder deflector	1
	58322								Rivet — Brazier head .126 dia x .310 in. long (deflector)	8
	58323								Rivet — Brazier head .126 dia x .375 in. long (deflector)	2
	57945								Rivet — Brazier head .095 dia x .250 in. long (deflector)	4
	35439								Rivet — Countersunk head $\frac{3}{32}$ dia x $\frac{1}{4}$ in. long (deflector)	6
	204446								Rivet — Universal head .126 dia x .219 in. long (deflector; <i>supersedes</i> No. 58227)	5
6	39988								Deflector Assembly — Inter cylinder (cylinders No. 2-3; for all engines except AN-2, -8 & B4)	1
	*39987								Deflector — Inter cylinder	1
	24883								Guide — Inter cylinder deflector	1
6	24884								Bolt — Latch — Inter cylinder deflector	2
6	14013								Spring — Deflector	1
	12012								Grommet — $\frac{5}{16}$ ID x $\frac{13}{16}$ OD x $\frac{5}{16}$ in. thick (inter ear deflector primer)	1
	23612								Nut — Anchor elastic stop $\frac{1}{4}$ -28 thd (deflector)	1
	151627								Strip — Inter cylinder deflector bearing left	1
	73988								Strip — Inter cylinder deflector bearing right	1
	78928								Plate — Inter cylinder deflector reinforcing	1
	74013								Brace — Inter cylinder deflector large	1
	73989								Plate — Inter cylinder deflector reinforcement	1
	58322								Rivet — Brazier head .126 dia x .310 in. long (deflector)	6
	58332								Rivet — 100° Countersunk head x .126 dia x .313 in. long (deflector; <i>supersedes</i> No. 58322)	4
	58323								Rivet — Brazier head .126 dia x .375 in. long (deflector)	4
	57945								Rivet — Brazier head .095 dia x .250 in. long (deflector)	4
	204446								Rivet — Universal head .126 dia x .219 in. long (deflector; <i>supersedes</i> No. 58227)	5
	80137								Deflector Assembly — Inter cylinder (cylinders No. 2-3; for B4 only)	1
	*80136								Deflector — Inter cylinder	1
	24883								Guide — Deflector	1
6	24884								Bolt — Latch — Inter cylinder deflector	2
6	14013								Spring — Deflector	1
	12012								Grommet — $\frac{5}{16}$ ID x $\frac{13}{16}$ OD x $\frac{5}{16}$ in. thick (deflector)	1
	151627								Strip — Inter cylinder deflector bearing left	1
	73988								Strip — Inter cylinder deflector bearing right	1
	74013								Brace — Inter cylinder deflector	1
	78928								Plate — Inter cylinder deflector reinforcement	1
	74015								Collar — Inter cylinder deflector	1
	57945								Rivet — Brazier head .095 dia x .250 in. long (deflector)	4
	58321								Rivet — Brazier head .126 x .281 in. long (deflector)	6
	204446								Rivet — Universal head .126 dia x .219 in. long (deflector; <i>supersedes</i> No. 58227)	5
	58322								Rivet — Brazier head .126 dia x .310 in. long (deflector)	6
	58332								Rivet — 100° Countersunk head x .126 dia x .313 in. long (deflector; <i>supersedes</i> No. 58322)	4
	58323								Rivet — Brazier head .126 dia x .375 in. long (deflector)	4
	73989								Plate — Inter cylinder deflector attaching	1
	23612								Nut — Anchor elastic stop $\frac{1}{4}$ -28 thd (deflector)	1
6	41463								Deflector Assembly Complete — Inter cylinder (cylinders No. 5-6 sump; for all engines except B4)	1
	71538								Deflector Assembly — Inter cylinder (for all engines except B4)	1
	*41462								Deflector — Inter cylinder left	1
	*151744								Deflector — Inter cylinder right	1
	82516								Bracket — Inter cylinder deflector right	1
	265149								Screw — Round head No. 10-32 thd x $\frac{1}{2}$ in. long (deflector; <i>supersedes</i> No. 13705)	1
	82517								Bracket Assembly — Inter cylinder deflector right (for all engines except B4)	1
	82515								Bracket — Inter cylinder deflector right	1
	71148								Nut — Fibre insert — Deflector	1
	35439								Rivet — Countersunk head $\frac{3}{32}$ dia x $\frac{1}{4}$ in. long (deflector)	2

DEFLECTORS

Figure Number	Part Number	1	2	3	4	5	6	7	Nomenclature	Units Per Assy
	71147								Bracket — Inter cylinder deflector left	1
	71149								Bracket Assembly — Inter cylinder deflector left (for all engines except B4)	1
	71145								Bracket — Inter cylinder deflector left	1
	71148								Nut — Fibre insert — Deflector	1
	35439								Rivet — Countersunk head $\frac{3}{32}$ dia x $\frac{1}{4}$ in. long (deflector)	2
	265149								Screw — Round head No. 10-32 thd x $\frac{1}{2}$ in. long (deflector; <i>supersedes</i> No. 13705)	1
	35431								Spring — Dzus fastener — Deflector	2
	35432								Washer — .126 ID x $\frac{1}{4}$ OD x .025 in. thick (deflector)	4
	49404								Guide — Inter cylinder deflector left hand	1
	49405								Guide — Inter cylinder deflector right hand	1
	106230								Stiffener — Inter cylinder deflector left hand	1
	106229								Stiffener — Inter cylinder deflector right hand	1
	106231								Strip — Inter cylinder deflector right	1
	106232								Strip — Inter cylinder deflector left	1
	115683								Strip — Inter cylinder deflector joining left	1
	115684								Strip Assembly — Inter cylinder deflector joining right (for all engines except B4)	1
	74018								Strip — Inter cylinder deflector nose left hand	1
	74017								Strip — Inter cylinder deflector nose right	1
6	93314								Spring — Inter cylinder deflector guide	2
6	49406								Latch — Inter cylinder deflector left hand	1
6	49407								Latch — Inter cylinder deflector right hand	1
	106233								Seal — Inter cylinder deflector right	1
	106234								Seal — Inter cylinder deflector left	1
	729								Screw — Round head No. 10-32 thd x $\frac{3}{8}$ in. long (deflector)	1
	35438								Rivet — Countersunk head .126 dia x .375 in. long (deflector)	4
	58322								Rivet — Brazier head .126 dia x .310 in. long (deflector)	8
	57945								Rivet — Brazier head .095 dia x .250 in. long (deflector)	2
	35439								Rivet — Countersunk head $\frac{3}{32}$ dia x $\frac{1}{4}$ in. long (deflector)	6
	58404								Rivet — Brazier head .095 dia x .344 in. long (deflector)	20
	58323								Rivet — Brazier head .126 dia x .375 in. long (deflector)	2
6	49403								Plate Assembly — Inter cylinder deflector (for all engines except B4)	1
	49402								Plate — Inter cylinder deflector	1
	49353								Fastener — Dzus type — Deflector	2
	76328								Deflector Assembly — Inter cylinder (cylinders No. 5-6 sump; for B4 only)	1
	*76329								Deflector — Inter cylinder	1
	24883								Guide — Inter cylinder deflector	1
6	14013								Spring — Deflector	1
6	24884								Bolt — Latch — Inter cylinder deflector	2
	204446								Rivet — Universal head .126 dia x .219 in. long (deflector; <i>supersedes</i> No. 58227)	5
	74013								Brace — Inter cylinder deflector large	1
	58322								Rivet — Brazier head .126 dia x .310 in. long (deflector)	8
	151627								Strip — Inter cylinder deflector bearing left	1
	73988								Strip — Inter cylinder deflector bearing right	1
	57945								Rivet — Brazier head .095 dia x .250 in. long (deflector)	4
	73981								Plate — Inter deflector reinforcement	1
	23612								Nut — Anchor elastic stop $\frac{1}{4}$ -28 thd (deflector)	1
	76284								Brace — Inter cylinder deflector center	1
	74016								Strip — Inter cylinder deflector nose	1
	35439								Rivet — Countersunk head $\frac{3}{32}$ dia x $\frac{1}{4}$ in. long (deflector)	2
	12012								Grommet — $\frac{5}{16}$ ID x $\frac{11}{16}$ OD x $\frac{5}{16}$ in. thick (inter car deflector primer)	1
	58323								Rivet — Brazier head .126 dia x .375 in. long (deflector)	2
	77323								Brace — Inter cylinder deflector nose	1
	76785								Rivet — Countersunk head .095 dia x .313 in. long (deflector)	4

DEFLECTORS

Figure Number	Part Number	1	2	3	4	5	6	7	Nomenclature	Units Per Assy
6	39986								Deflector Assembly — Inter cylinder (cylinders No. 3-4 & 8-9; for all engines except AN-2, -8, B4, B3 & B5 with magneto SB9RN)	2
	*39985								Deflector — Inter cylinder	1
6	24884								Bolt — Latch — Inter cylinder deflector	2
6	14013								Spring — Deflector	1
	24883								Guide — Inter cylinder deflector	1
	12012								Grommet — $\frac{5}{16}$ ID x $1\frac{13}{16}$ OD x $\frac{5}{16}$ in. thick (inter ear deflector primer)	1
	151627								Strip — Inter cylinder deflector bearing left	1
	73988								Strip — Inter cylinder deflector bearing right	1
	23612								Nut — Anchor elastic stop $\frac{1}{4}$ -28 thd (deflector)	1
	74016								Strip — Inter cylinder deflector nose blank	1
	74013								Brace — Inter cylinder deflector large	1
	74012								Brace — Inter cylinder deflector small	1
	73981								Plate — Inter cylinder deflector reinforcement	1
	58322								Rivet — Brazier head .126 dia x .310 in. long (deflector)	8
	58323								Rivet — Brazier head .126 dia x .375 in. long (deflector)	2
	57945								Rivet — Brazier head .095 dia x .250 in. long (deflector)	4
	35439								Rivet — Countersunk head $\frac{3}{32}$ dia x $\frac{1}{4}$ in. long (deflector)	6
	204446								Rivet — Universal head .126 dia x .219 in. long (deflector; <i>supersedes No. 58227</i>)	5
	40593								Deflector Assembly — Inter cylinder (cylinders No. 8-9 for B4)	1
	*40592								Deflector — Inter cylinder	1
	24883								Guide — Deflector	1
6	24884								Bolt — Latch — Inter cylinder deflector	2
6	14013								Spring — Deflector	1
	12012								Grommet — $\frac{5}{16}$ ID x $1\frac{13}{16}$ OD x $\frac{5}{16}$ in. thick (deflector)	1
	23612								Nut — Anchor elastic stop $\frac{1}{4}$ -28 thd (deflector)	1
	73984								Collar — Inter cylinder deflector	1
	74013								Brace — Inter cylinder deflector large	1
	74012								Brace — Inter cylinder deflector small	1
	151627								Strip — Inter cylinder deflector bearing left	1
	73988								Strip — Inter cylinder deflector bearing right	1
	74016								Strip — Inter cylinder deflector nose blank	1
	73981								Plate — Inter cylinder deflector reinforcing	1
	58322								Rivet — Brazier head .126 dia x .310 in. long (deflector)	8
	58323								Rivet — Brazier head .126 dia x .375 in. long (deflector)	2
	57945								Rivet — Brazier head .095 dia x .250 in. long (deflector)	4
	35439								Rivet — Countersunk head $\frac{3}{32}$ dia x $\frac{1}{4}$ in. long (deflector)	6
	204446								Rivet — Universal head .126 dia x .219 in. long (deflector; <i>supersedes No. 58227</i>)	5
	58321								Rivet — Brazier head .126 dia x .281 in. long (deflector)	6
6	39992								Deflector Assembly — Inter cylinder (cylinders No. 7-8; for all AN engines except AN-2 & -8; for B3 & B5 engines with magneto SB9RN-4)	1
	*39991								Deflector — Inter cylinder	1
6	14013								Spring — Deflector	1
6	24884								Bolt — Latch — Inter cylinder deflector	2
	24883								Guide — Inter cylinder deflector	1
	12012								Grommet — $\frac{5}{16}$ ID x $1\frac{13}{16}$ OD x $\frac{5}{16}$ in. thick (inter ear deflector primer)	1
	23612								Nut — Anchor elastic stop $\frac{1}{4}$ -28 thd (deflector)	1
	151627								Strip — Inter cylinder deflector bearing left	1
	73988								Strip — Inter cylinder deflector bearing right	1
	74016								Strip — Inter cylinder deflector nose blank	1
	74013								Brace — Inter cylinder deflector large	1
	74012								Brace — Inter cylinder deflector small	1
	73981								Plate — Inter cylinder deflector reinforcement	1
	58322								Rivet — Brazier head .126 dia x .310 in. long (deflector)	8
	58323								Rivet — Brazier head .126 dia x .375 in. long (deflector)	2
	57945								Rivet — Brazier head .095 dia x .250 in. long (deflector)	4
	35439								Rivet — Countersunk head $\frac{3}{32}$ dia x $\frac{1}{4}$ in. long (deflector)	6
	204446								Rivet — Universal head .126 dia x .219 in. long (deflector; <i>supersedes No. 58227</i>)	5

DEFLECTORS

Figure Number	Part Number	1	2	3	4	5	6	7	Nomenclature	Units Per Assy
	76330								Deflector Assembly — Inter cylinder (cylinders No. 7-8; for B4 only)	1
	*76331								Deflector — Inter cylinder	1
	24883								Guide — Inter cylinder deflector	1
6	14013								Spring — Deflector	1
6	24884								Bolt — Latch — Inter cylinder deflector	2
	204446								Rivet — Universal head .126 dia x .219 in. long (deflector; <i>supersedes No. 58227</i>)	5
	74013								Brace — Inter cylinder deflector large	1
	58322								Rivet — Brazier head .126 dia x .310 in. long (deflector)	8
	151627								Strip — Inter cylinder deflector bearing left	1
	73988								Strip — Inter cylinder deflector bearing right	1
	57945								Rivet — Brazier head .095 dia x .250 in. long (deflector)	4
	73981								Plate — Inter cylinder deflector reinforcement	1
	23612								Nut — Anchor elastic stop 1/4-28 thd (deflector)	1
	58323								Rivet — Brazier head .126 dia x .375 in. long (deflector)	2
	74012								Brace — Inter cylinder deflector small	1
	74016								Strip — Inter cylinder deflector nose	1
	35439								Rivet — Countersunk head 3/32 dia x 1/4 in. long (deflector)	6
	12012								Grommet — 5/16 ID x 13/16 OD x 3/16 in. thick (inter ear deflector primer)	1
6	39990								Deflector Assembly — Inter cylinder (cylinders No. 1-2; for all AN engines except AN-2 & -8; for B3 & B5 engines with magneto SB9RN-4)	1
	*39989								Deflector — Inter cylinder	1
6	24884								Bolt — Latch — Inter cylinder deflector	2
6	14013								Spring — Deflector	1
	24883								Guide — Inter cylinder deflector	1
	12012								Grommet — 5/16 ID x 13/16 OD x 3/16 in. thick (inter ear deflector primer)	1
	23612								Nut — Anchor elastic stop 1/4-28 thd (deflector)	1
	151627								Strip — Inter cylinder deflector bearing left	1
	73988								Strip — Inter cylinder deflector bearing right	1
	74016								Strip — Inter cylinder deflector nose blank	1
	74013								Brace — Inter cylinder deflector large	1
	74012								Brace — Inter cylinder deflector small	1
	73981								Plate — Inter cylinder deflector reinforcement	1
	58322								Rivet — Brazier head .126 dia x .310 in. long (deflector)	8
	58323								Rivet — Brazier head .126 dia x .375 in. long (deflector)	2
	57945								Rivet — Brazier head .095 dia x .250 in. long (deflector)	4
	35439								Rivet — Countersunk head 3/32 dia x 1/4 in. long (deflector)	6
	204446								Rivet — Universal head .126 dia x .219 in. long (deflector; <i>supersedes No. 58227</i>)	5
	40589								Deflector Assembly — Inter cylinder (cylinders No. 4-5; for B4 only)	1
	*40588								Deflector — Inter cylinder	1
	24883								Guide — Inter cylinder deflector	1
6	24884								Bolt — Latch — Inter cylinder deflector	2
6	14013								Spring — Deflector	1
	74088								Screen — Inter cylinder deflector scoop	1
	143774								Strip — Inter cylinder deflector bearing	1
	73988								Strip — Inter cylinder deflector bearing	1
	74016								Strip — Inter cylinder deflector nose blank	1
	74012								Brace — Inter cylinder deflector small	1
	73990								Plate — Inter cylinder deflector reinforcement	1
	*173595								Scoop — Inter cylinder deflector left half	1
	*173596								Scoop — Inter cylinder deflector right half	1
	204446								Rivet — Universal head .126 dia x .219 in. long (deflector; <i>supersedes No. 58227</i>)	5
	139479								Rivet — Universal head .094 dia x .250 in. long (deflector; <i>supersedes No. 57945</i>)	4
	126832								Rivet — Universal head .126 dia x .312 in. long (deflector; <i>supersedes No. 58322</i>)	2
	126833								Rivet — Universal head .126 dia x .381 in. long (deflector; <i>supersedes No. 58321</i> for (4) units)	28
	35439								Rivet — Countersunk head 3/32 dia x 1/4 in. long (deflector)	6
	143575								Rivet — Universal head .095 dia x .219 in. long (deflector; <i>supersedes No. 58328</i>)	6

DEFLECTORS

Figure Number	Part Number	1	2	3	4	5	6	7	Nomenclature	Units Per Assy
	126344								Rivet — Universal head .126 dia x .344 in. long (deflector)	2
	38987								Plate & Stud Assembly — Inter cylinder deflector clamp (use with cylinders No. 4-5 deflectors; for B4 only)	1
	73991								Plate — Inter cylinder deflector clamp	1
	20251								Stud — Inter cylinder deflector clamp	1
	58322								Rivet — Brazier head .126 dia x .310 in. long (deflector)	3
6	40000								Clamp Assembly — Inter cylinder deflector (for all locations except cylinders No. 5-6)	8
	39999								Clamp — Inter cylinder deflector	1
	39998								Yoke — Inter cylinder deflector	1
	58322								Rivet — Brazier head .126 dia x .310 in. long (deflector)	6
6	39997								Bolt & Wing Nut Assembly — Inter cylinder deflector (for all locations except cylinders No. 5-6; use No. AS 100029 wire)	8
6	12376								Washer — Plain $1\frac{1}{4}$ ID x $\frac{3}{4}$ OD x $\frac{1}{16}$ in. thick (use (8) units for all engines except B4 — for use with Part No. 39997 bolt & wing nut assembly; on B4 use extra unit on Part No. 5610 wing nut)	9
	5610								Nut — Wing $\frac{1}{4}$ -20 thd x $1\frac{1}{16}$ in. thick (inter cylinder deflector — use (1) unit for B4 between cylinders No. 4-5 on Part No. 38987 plate & stud assembly; use No. AS 100029 wire)	3
6	33415								Nut — Fibre insert $\frac{5}{16}$ -24 thd x $\frac{23}{64}$ in. thick (inter ear deflectors to cylinder head attaching)	18

OIL SUMP

Figure Number	Part Number	1	2	3	4	5	6	7	Nomenclature	Units Per Assy
	81185								Sump & Strainer Assembly Complete — Oil (for all engines except B4)	1
7	48393								Sump Assembly Complete — Oil (for all engines except B4)	1
	*48392								Sump Machining Assembly — Oil (for all engines except B4)	1
	*48388								Sump Casting Assembly — Oil (for all engines except B4)	1
	†20117								Bushing — Flanged 1.18 ID x $1\frac{1}{4}$ -12 OD x $\frac{23}{32}$ in. long (oil sump drain plugs; for all engines except B4)	2
	20117+3								Bushing same as 20117 only .003 in. oversize	
7	91453								Plug — Hexagon socket .500 ANPT x .375 in. long Special (oil sump; supersedes No. 89252 for all engines except B4)	3
7	91454								Plug — Hexagon socket .125 ANPT x .375 in. long Special (oil sump; supersedes No. 138 & 89884 for all engines except B4)	1
	143								Plug — Welch 1.375 in. dia (oil sump; for all engines except B4)	1
7	156011								Disc — Name plate mount (supersedes No. 22464; for all engines except B4)	1
7	156010								Spacer — 1.040-1.080 ID x 1.996-2.000 OD x .010-.020 in. thick (name plate mount disc)	1
7	215								Screw — Flat head No. 8-32 thd x $\frac{5}{16}$ in. long (name plate mount disc; for all engines except B4)	4
7	134448								Plate — Company name (supersedes No. 1196; for all engines except B4)	1
	237								Gasket — 1.008 ID x 1.250 OD x .094 in. thick (oil sump drain plug; for all engines except B4)	2
7	20126								Plug — 1 Hexagon head x No. 1-18 thd x $\frac{31}{32}$ in. long (oil sump drain; use No. AS 100029 wire; for all engines except B4)	2
	19865								Plug — .438 Square head x .375-18 Pipe x .796 in. long (oil sump; use No. AS 100029 wire; for all engines except B4)	1
7	†39079+4								Stud — Plain .3125-18-24 thd x 1.438 in. long (rocket oil drain fitting; supersedes No. 9085 for all engines except B4) .004 in. oversize	2
	39079+8								Stud same as 39079 only .008 in. oversize	
	39079+12								Stud same as 39079 only .012 in. oversize	

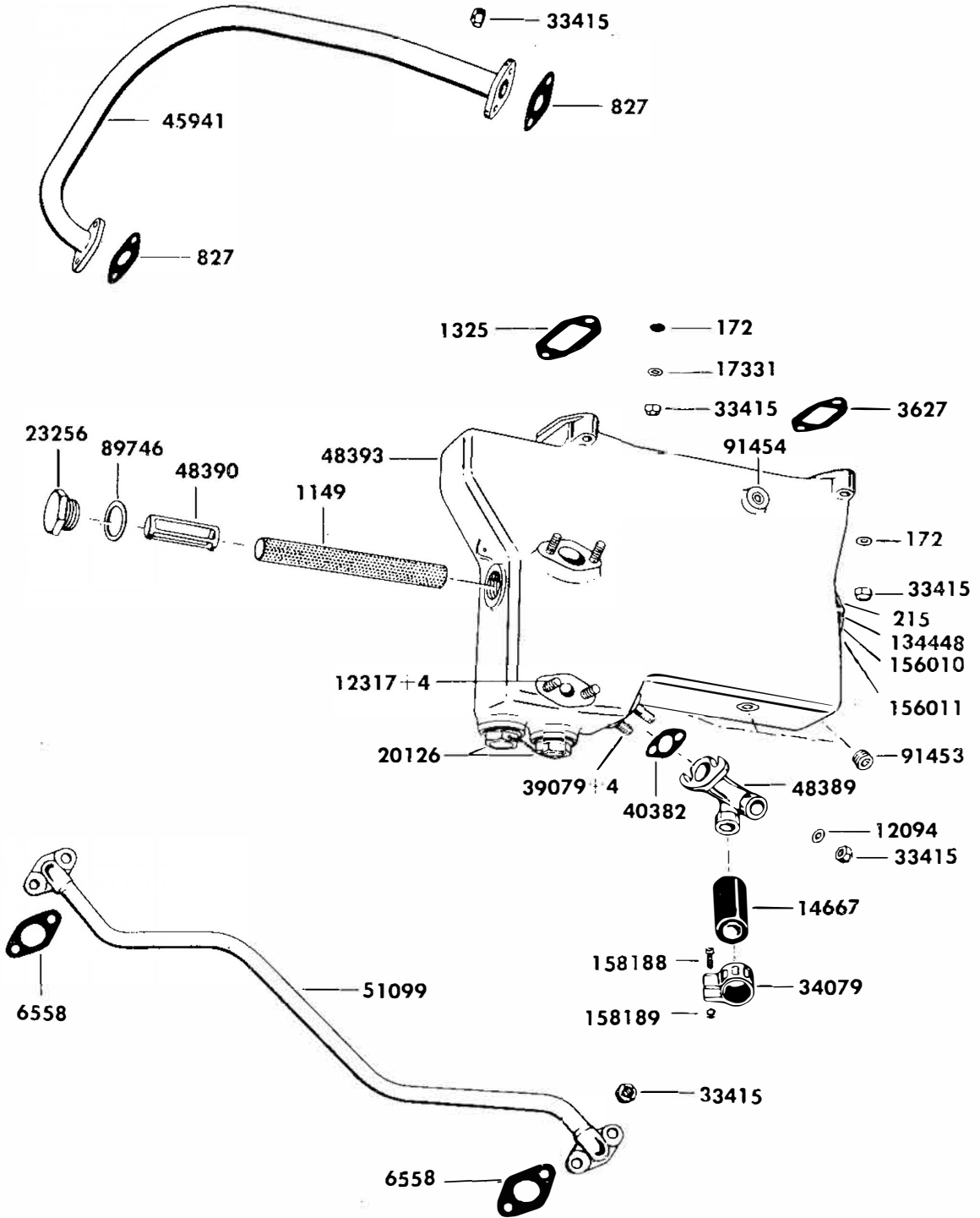

Figure 7. Oil Sump

International AeroTech Academy For Training Purpose Only

OIL SUMP

Figure Number	Part Number	Nomenclature							Units Per Assy
		1	2	3	4	5	6	7	
7	†12317+4							Stud — Plain .3125-18-24 thd x 1.312 in. long (rear oil pump oil scavenge pipes; for all engines except B4) .004 in. oversize	4
	12317+8							Stud same as 12317 only .008 in. oversize	
	12317+12							Stud same as 12317 only .012 in. oversize	
7	1149							Strainer — Oil sump (for all engines except B4)	1
7	48390							Retainer — Oil strainer (for all engines except B4)	1
7	89746							Gasket — 1.000 ID x 1.250 OD x .078 in. thick (sump oil strainer hole plug; <i>supersedes</i> No. 237 for all engines except B4)	1
7	23256							Plug — 1 $\frac{1}{4}$ Hexagon head x 1-14 thd x $\frac{5}{8}$ in. long (sump oil strainer hole; for all engines except B4)	1
7	40382							Gasket — $\frac{3}{4}$ in. Pipe flanged (rocker oil drain fitting; for all engines except B4)	1
7	49389							Fitting — Rocker oil drain (for all engines except B4)	1
7	12094							Washer — Plain $\frac{21}{64}$ ID x $\frac{11}{16}$ OD x $\frac{3}{32}$ in. thick (rocker oil drain fitting; <i>supersedes</i> No. 176 for all engines except B4)	2
7	33415							Nut — Fibre insert $\frac{5}{16}$ -24 thd x $\frac{23}{64}$ in. thick (rocker oil drain fitting; for all engines except B4)	2
7	3627							Gasket — Oil sump to nose housing	1
	74929							Cover — Sump pad front (for B4 only)	1
7	1325							Gasket — Oil sump to blower crankcase	1
	74932							Cover — Sump pad rear (<i>supersedes</i> No. 44932; for B4 only)	1
7	17331							Washer — Plain $\frac{21}{64}$ ID x $\frac{9}{16}$ OD x $\frac{1}{8}$ in. thick (oil sump rear attaching studs; for all engines except B4)	2
7	172							Washer — Plain $\frac{21}{64}$ ID x $\frac{9}{16}$ OD x $\frac{1}{16}$ in. thick (oil sump attaching studs)	4
7	33415							Nut — Fibre insert $\frac{5}{16}$ -24 thd x $\frac{23}{64}$ in. thick (oil sump attaching studs)	4
7	6558							Gasket — .531 ID Pipe flanged x .031 in. thick (rocker drain oil suction pipe; use (1) unit for B4 front case to rear pipe flange)	2
7	51099							Pipe Assembly — Rocker drain oil suction (for all engines except B4)	1
7	33415							Nut — Fibre insert $\frac{5}{16}$ -24 thd x $\frac{23}{64}$ in. thick (rocker drain oil suction pipe; use (2) units for B4 rear oil scavenge pipe flange)	4
7	827							Gasket — .688 ID Pipe flanged x .031 in. thick (main oil suction pipes; for all engines except B4)	2
7	45941							Pipe Assembly — Main oil suction (for all engines except B4)	1
7	33415							Nut — Fibre insert $\frac{5}{16}$ -24 thd x $\frac{23}{64}$ in. thick (main oil suction pipe; use (2) units for B4 front case to rear pipe flange)	4
7	14667							Hose — .750 ID x 1.625 in. long (cylinders No. 5 & 6; rocker box covers to rocker oil drain fitting; for all engines except B4)	2
7	34079							Clamp Assembly — 1.125 in. ID Hose (oil drain hose; for all engines except B4)	4
7	158188							Screw — Oil drain hose clamp	1
7	158189							Nut — Fibre .190-24 thd x .266 in. thick Special (oil drain hose clamp screw)	1

COLLECTOR CASE AND INTAKE PIPES

Figure Number	Part Number	Nomenclature							Units Per Assy
		1	2	3	4	5	6	7	
8	126308							Case & Studs Assembly — Collector (<i>supersedes</i> No. 47972 for AN engines)	1
8	126307							Case & Studs Assembly — Collector (<i>supersedes</i> No. 40987 for B3 & B5)	1
	126310							Case & Studs Assembly — Collector (replaces No. 126309; for B4 with oil seals)	1
	*121211							Case Machining Assembly — Collector (replaces No. 86883; for use with Part No. 126310 collector case)	1
	1989							Pipe — Impeller air bleed (for all engines except B4)	2
8	13651							Fitting — Collector section oil pressure connection	1
8	4199							Pin — Straight .156 dia x 1.031 in. long (oil pressure fitting)	1
	8846							Tube — Internal breather (for all engines except B4)	2
8	21896							Jet — Collector section oil	1

COLLECTOR CASE AND INTAKE PIPES

Figure Number	Part Number	1	2	3	4	5	6	7	Nomenclature	Units Per Assy
	80486								Bearing & Liner Assembly — Impeller shaft (for B4 only)	1
	*80484								Liner — Impeller shaft (for B4 only)	1
	80485								Bearing — Impeller shaft front (for B4 only)	1
	43568								Pin — Straight .1285 dia x .344 in. long (impeller shaft front bearing; for B1 only)	1
	80483								Bearing — Flanged 1.555 ID x 1.798 OD x .946 in. long (impeller shaft rear; for B4 only)	1
	4229								Pin — Straight .1285 dia x .281 in. long (impeller shaft rear bearing; for B1 only)	1
8	5025								Cage — Collector intermediate shaft ball bearing	1
8	24								Pin — Straight .093 dia x .219 in. long (collector intermediate shaft ball bearing cage)	1
	†19649								Plug — Plain slotted 1/4-20 thd x 1/4 in. long (hole in cylinder No. 5 intake port)	1
	19649+4								Plug same as 19649 only .004 in. oversize	
	19649+8								Plug same as 19649 only .008 in. oversize	
	11521								Plug — Hexagon socket .125 in. ANPT (holes each side of cylinder No. 6 intake port)	2
8	17346								Plug — .281 Square head x .125-27 Pipe x .578 in. long (manifold pressure gauge connections)	3
	†9252+4								Stud — Plain .3125-18-24 thd x 2.094 in. long (oil sump fastening; for all engines except B4) .004 in. oversize	2
	9252+8								Stud same as 9252 only .008 in. oversize	
	9252+12								Stud same as 9252 only .012 in. oversize	
	†90105+4								Stud — Plain .3125-18-24 thd x 2.094 in. long (oil sump fastening; for B4 only) .004 in. oversize	2
	90105+8								Stud same as 90105 only .008 in. oversize	
	†7959+4								Stud — Plain .3125-18-24 thd x 1.844 in. long (collector to rear case) .004 in. oversize	3
	7959+8								Stud same as 7959 only .008 in. oversize	
	7959+12								Stud same as 7959 only .012 in. oversize	
	†89102								Stud — Plain .3125-18-24 thd x 1.438 in. long (collector to rear case; <i>supersedes</i> No. 625; use (7) units for B3 & B5)	9
	89102+4								Stud same as 89102 only .004 in. oversize	
	89102+8								Stud same as 89102 only .008 in. oversize	
	†11345+4								Stud — Plain .3125-18-24 thd x 1.562 in. long (collector to rear case; use (2) units for all engines except B3 & B5) .004 in. oversize	1
	11345+8								Stud same as 11345 only .008 in. oversize	
	11345+12								Stud same as 11345 only .012 in. oversize	
	†9085+4								Stud — Plain .3125-18-24 thd x 1.375 in. long (collector to rear case) .004 in. oversize	1
	9085+8								Stud same as 9085 only .008 in. oversize	
	9085+12								Stud same as 9085 only .012 in. oversize	
	†9385+4								Stud — Plain .3125-18-24 thd x 2.281 in. long (collector to rear case) .004 in. oversize	1
	9385+8								Stud same as 9385 only .008 in. oversize	
	9385+12								Stud same as 9385 only .012 in. oversize	
	†12054+4								Stud — Plain .3125-18-24 thd x 1.250 in. long (oil drain pipe connection) .004 in. oversize	1
	12054+8								Stud same as 12054 only .008 in. oversize	
	12054+12								Stud same as 12054 only .012 in. oversize	
	45173								Pin — .0937-.0957 dia x .250 in. long (oil jet; for B1 only)	1
	†121203								Tube — Collector case to rear case oil drain (replaces No. 86826; use with Part No. 126310 collector case)	1
	121203+10								Tube same as 121203 only .010 in. oversize	
	121203+20								Tube same as 121203 only .020 in. oversize	
	121203+30								Tube same as 121203 only .030 in. oversize	
	†121202								Tube — Collector case to rear case oil drain (replaces No. 86890; use with Part No. 126310 collector case)	1
	121202+10								Tube same as 121202 only .010 in. oversize	
	121202+20								Tube same as 121202 only .020 in. oversize	
	121202+30								Tube same as 121202 only .030 in. oversize	

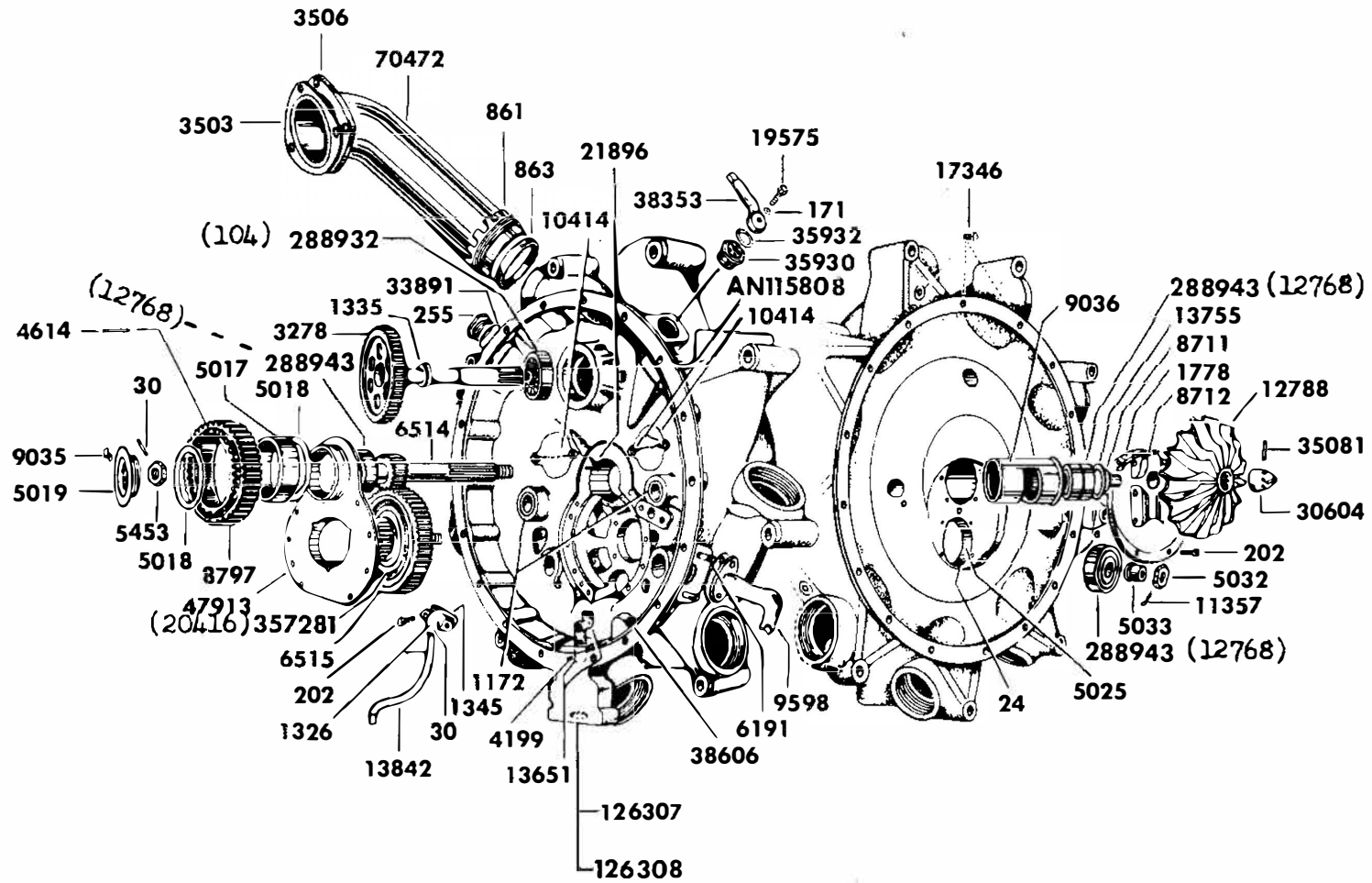

Figure 8. Collector Case and Intake Pipes

COLLECTOR CASE AND INTAKE PIPES

Figure Number	Part Number	Nomenclature							Units
		1	2	3	4	5	6	7	Per Assy
	†15	Pin — Straight .1285 dia x .406 in. long (oil drain tube; for B4 only)							
	15+10	Pin same as 15 only .010 in. oversize							
	15+20	Pin same as 15 only .020 in. oversize							
	15+30	Pin same as 15 only .030 in. oversize							
8	†1172	Bushing — Magneto drive shaft short							
	1172+2	Bushing same as 1172 only .002 in. oversize							
	1172+3	Bushing same as 1172 only .003 in. oversize							
	1172+5	Bushing same as 1172 only .005 in. oversize							
	1172+10	Bushing same as 1172 only .010 in. oversize							
	1172+15	Bushing same as 1172 only .015 in. oversize							
	1172+20	Bushing same as 1172 only .020 in. oversize							
	1172+25	Bushing same as 1172 only .025 in. oversize							
	1172+30	Bushing same as 1172 only .030 in. oversize							
	1172+40	Bushing same as 1172 only .040 in. oversize							
8	10414	Plate — Crankcase collector section (for all engines except B4)							2
8	AN 115808	Screw — Flat fillister drilled head .190 (No. 10)-32NF 3A thd x .438 in. long (crankcase collector section plate; use No. 192 wire; supersedes No. 282; for all engines except B4)							4
8	†9036	Cage — Collector shaft ball bearing (for all engines except B4)							1
	9036+5	Cage same as 9036 only .005 in. oversize							
8	1778	Gasket — Collector bearing cover (for all engines except B4)							1
8	8712	Cover Assembly — Collector bearing (for all engines except B4)							1
	*8710	Cover — Collector bearing (for all engines except B4)							1
	7644	Pin — Straight .165 dia x .781 in. long (collector bearing cover; for all engines except B4)							2
	AN 122705	Pin — Dowel, steel .1875 dia x .500 in. long (collector bearing cover; supersedes No. 7577; for all engines except B4)							2
8	202	Screw — Fillister head drilled 1/4-20 thd x 9/16 in. long (collector bearing cover; use No. AS 100029 wire; for all engines except B4)							8
	36090	Seal — .750 ID x .125 in. thick (collector case to rear case oil drain tube; for use with Part No. 126310 collector case)							2
	44076	Seal — .438 ID x .125 in. thick (collector case to rear case oil drain tube; for use with Part No. 126310 collector case)							1
	80493	Cover Assembly — Impeller shaft bearing (for B4 only)							1
	*80492	Cover — Collector bearing (for B4 only)							1
	87241	Seal — Oil 1.032 ID x 2.004 OD x .750 in. thick (impeller shaft oil; for B4 only)							1
	AN 122705	Pin — Dowel, steel .1875 dia x .500 in. long (collector bearing cover; supersedes No. 7577; for B4 only)							2
	14438	Seal — 4.625 ID x .113 in. dia Round (impeller shaft bearing cover; for B4 only)							1
	38602	Screw — Flat fillister head 1/4-20 thd x 9/16 in. long (impeller cover; for B4 only)							8
8	288943	Bearing Option — Collector intermediate (procurement number consists of: Part No. 12768 Bearing — Ball .7874 ID x 2.0472 OD x .5906 in. long (optional to Part No. 288910 or 359236) Part No. 288910 Bearing — Ball .7874 ID x 2.0472 OD x .5906 in. Wide (optional to Part No. 12768 or 359236) Part No. 359236 Bearing — Ball .7874 ID x 2.0472 OD x .5906 in. Wide (optional to Part No. 12768 or 288910)							1
8	5033	Spacer — Collector intermediate bearing							1
8	357281	Bearing Option — Collector intermediate (supersedes No. 12769; procurement number consists of: Part No. 20416 Bearing — Ball 1.7717 ID x 2.0472 OD x .5906 in. long (optional to Part No. 357276) Part No. 357276 Bearing — Ball 1.7717 ID x 2.0472 OD x .5906 in. Wide (optional to Part No. 20416)							1
8	6515	Gear — 10:1 (collector intermediate)							1
8	5032	Nut — Plain 1 1/8 Hexagon head x 1/2-20 thd x 5/16 in. thick (collector intermediate gear)							1
8	11357	Cotterpin — .086-.090 dia x 1.250 in. long (collector intermediate gear nut)							1
8	47913	Cage Assembly — Main collector drive (for all engines except B4)							1

COLLECTOR CASE AND INTAKE PIPES

Figure Number	Part Number	1	2	3	4	5	6	7	Nomenclature	Units Per Assy
	97927								Cage Assembly — Collector drive (for B4 only)	1
	*5021								Cage — Impeller intermediate gear front bearing (for all engines except B4)	1
	*80494								Cage — Impeller shaft bearing (for B4 only)	1
	46816								Pin — Straight .156 dia x .203 in. long (impeller cage; <i>supersedes No. 47</i>)	1
8	202								Screw — Fillister head drilled $\frac{1}{4}$ -20 thd x $\frac{9}{16}$ in. long (impeller cage; <i>use No. AS 100029 wire</i>)	8
8	5017								Race — Inner roller bearing floating gear	1
8	5018								Spacer — Floating gear end thrust	1
8	8797								Gear — Collector drive floating	1
8	4614								Pin — Roller .1181 dia x .7795 in. long (collector drive floating gear)	79
8	5018								Spacer — Floating gear end thrust	1
8	288943								Bearing Option — Collector intermediate (procurement number consists of: Part No. 12768 Bearing — Ball .7874 ID x 2.0472 OD x .5906 in. long (optional to Part No. 288910 or 359236) Part No. 288910 Bearing — Ball .7874 ID x 2.0472 OD x .5906 in. Wide (optional to Part No. 12768 or 359236) Part No. 359236 Bearing — Ball .7874 ID x 2.0472 OD x .5906 in. Wide (optional to Part No. 12768 or 288910)	1
	19559								Impeller & Shaft Assembly — 10:1 (for all engines except B4)	1
	81058								Impeller & Shaft Assembly — (for B4 only)	1
8	12788								Impeller	1
8	6514								Shaft — Impeller (for all engines except B4)	1
	81170								Shaft Assembly — Impeller (for B4 only)	1
	*80487								Shaft — Impeller (for B4 only)	1
	80489								Journal — Impeller shaft (for B4 only)	1
8	5453								Nut — Plain $1\frac{1}{16}$ Hexagon head x $\frac{3}{4}$ -16 thd x $\frac{3}{16}$ in. thick (front impeller shaft; for all engines except B4)	1
	34749								Nut — Front impeller shaft (for B4 only)	1
8	30								Pin — Straight .098 dia x 1.375 in. long (front impeller shaft nut; for all engines except B4)	1
	2								Cotterpin — .072-.076 dia x 1.000 in. long (impeller shaft nut; for B4 only)	1
8	9035								Lock — Collector drive retaining nut	1
8	5019								Nut — Floating gear & blower shaft retainer	1
	80490								Spacer — Impeller shaft rear (for B4 only)	1
8	288943								Bearing Option — Impeller shaft (for all engines except B4; procurement number consists of: Part No. 12768 Bearing — Ball .7874 ID x 2.0472 OD x .5906 in. long (optional to Part No. 288910 or 359236) Part No. 288910 Bearing — Ball .7874 ID x 2.0472 OD x .5906 in. Wide (optional to Part No. 12768 or 359236) Part No. 359236 Bearing — Ball .7874 ID x 2.0472 OD x .5906 in. Wide (optional to Part No. 12768 or 288910)	2
8	13755								Baffle — Collector drive oil (for all engines except B4)	1
	5023								Closure — Collector shaft ball bearing (for all engines except B4)	1
8	†8711								Spacer — Rear collector shaft oil (for all engines except B4)	1
	8711+10								Spacer same as 8711 only .010 in. oversize	
	8711+20								Spacer same as 8711 only .020 in. oversize	
8	30604								Nut — Impeller	1
8	35081								Pin — .140 dia x 1 in. long (impeller nut)	1
8	1345								Gasket — .469 ID Pipe flanged x .031 in. thick (collector oil pressure pipe bracket)	1
8	13842								Nozzle & Bracket Assembly — Collector oil pressure	1
	*13841								Pipe & Nozzle Assembly — Collector oil pressure	1
8	1326								Bracket — Collector oil pressure pipe	1
8	30								Pin — Straight .098 dia x 1.375 in. long (oil pressure pipe to bracket)	1
8	202								Screw — Fillister head drilled $\frac{1}{4}$ -20 thd x $\frac{9}{16}$ in. long (oil bracket to collector housing; <i>use No. AS 100029 wire</i>)	2

COLLECTOR CASE AND INTAKE PIPES

Figure Number	Part Number	1	2	3	4	5	6	7	Nomenclature	Units Per Assy
8	33891								Seal — .656 ID x .094 in. thick (collector breather plug; use (1) unit for all engines except B4)	2
8	255								Plug — 1 $\frac{3}{8}$ -12 dia x $\frac{7}{16}$ in. long (collector case breather hole; use (1) unit for all engines except B4)	2
8	17346								Plug — .281 Square head x .125-27 Pipe x .578 in. long (collector case; use No. AS 100029 wire)	1
	6191								Gasket — .812 ID Pipe flanged x .031 in. thick (collector case pipe flange; for B4 only)	1
	75162								Flange — Blank .344 OD x .219 in. thick (collector case pipe opening; for B4 only)	1
	33415								Nut — Fibre insert $\frac{5}{16}$ -24 thd x $\frac{23}{64}$ in. thick (collector case blank flange; for B4 only)	2
	38436								Breather Assembly — Rear (for all engines except B4)	1
8	35932								Gasket — 1.281 ID x 1.500 OD x .031 in. thick (rear breather connection; for all engines except B4)	1
8	35930								Body — Breather connection (for all engines except B4)	1
	38354								Connection — Breather (for all engines except B4)	1
8	38353								Connection — Breather exhaust (for all engines except B4)	1
8	171								Washer — Plain $\frac{17}{64}$ ID x $\frac{1}{2}$ OD x $\frac{1}{16}$ in. thick (breather connection screw; for all engines except B4)	1
8	19575								Screw — $\frac{7}{16}$ Hexagon head drilled x $\frac{1}{4}$ -28 thd x $1\frac{1}{16}$ in. long (breather connection; for all engines except B4)	1
	38355								Clamp — Breather connection (for all engines except B4)	1
	265149								Screw — Round head No. 10-32 thd x $\frac{1}{2}$ in. long (breather connection clamp; <i>supersedes No. 13705</i> ; for all engines except B4)	1
	11748								Nut — Fibre insert No. 10-32 thd x $\frac{15}{64}$ in. thick (breather connection clamp; for all engines except B4)	1
	25049								Bolt — Plain .625 Hexagon head x .4375-14 thd x 3.938 in. long (engine mount)	8
	720								Washer — Plain $\frac{15}{32}$ ID x $\frac{7}{8}$ OD x $\frac{1}{16}$ in. thick (engine mount bolt)	8
	534								Nut — Plain $\frac{25}{32}$ Hexagon head x $\frac{7}{16}$ -14 thd x $\frac{7}{16}$ in. thick (engine mount bolt)	8
	25050								Nut — Plain $\frac{25}{32}$ Hexagon head x $\frac{7}{16}$ -14 thd x $\frac{9}{32}$ in. thick (engine mount bolt)	8
8	38606								Seal — 16.625 ID x .125 in. dia Round (collector to main crankcase; <i>supersedes No. 12584</i>)	1
9	1187								Gasket — Collector to rear crankcase	1
	172								Washer — Plain $\frac{21}{64}$ ID x $\frac{9}{16}$ OD x $\frac{1}{16}$ in. thick (collector to main crankcase)	1
	512								Nut — Plain $\frac{1}{2}$ Hexagon head x $\frac{5}{16}$ -24 thd x $\frac{17}{64}$ in. thick (collector to main crankcase)	1
	818								Palnut — .500 in. Hexagon head x .3125-24 PD (collector to main crankcase)	1
	173								Washer — Plain $\frac{25}{64}$ ID x $\frac{11}{16}$ OD x $\frac{1}{16}$ in. thick (collector to main crankcase)	17
	4381								Nut — Plain $\frac{9}{16}$ Hexagon head x $\frac{3}{8}$ -24 thd x $\frac{21}{64}$ in. thick (collector to main crankcase)	17
	AN 121504								Nut — Plain $\frac{9}{16}$ Hexagon head x .375-24 thd x .328 in. thick (collector to main crankcase)	13
	7635								Palnut — .562 in. Hexagon head x .375-24 PD (collector to main crankcase)	17
8	3503								Gasket — Intake & exhaust flange	18
8	70472								Pipe — Intake (<i>supersedes No. 7621</i>)	9
8	3506								Flange — 2.156 in. OD Pipe (intake pipe)	9
	10464								Flange — 2.156 in. OD Pipe (exhaust pipe; for all engines except B5)	9
8	863								Packing — Intake pipe	9
8	861								Nut — 2 $\frac{1}{2}$ -12 thd (intake pipe packing)	9
	172								Washer — Plain $\frac{21}{64}$ ID x $\frac{9}{16}$ OD x $\frac{1}{16}$ in. thick (intake pipe studs & bolt)	27
	4669								Screw — $\frac{1}{2}$ Hexagon head drilled x $\frac{5}{16}$ -18 thd x $1\frac{15}{16}$ in. long (intake pipe; use No. AS 100029 wire; <i>supersedes No. 206</i>)	9
	33415								Nut — Fibre insert $\frac{5}{16}$ -24 thd x $\frac{23}{64}$ in. thick (intake pipe studs)	18
	72430								Gasket — Exhaust port shipping cover	9
	3773								Cover — Exhaust port shipping (for all engines except B5)	9
	40383								Cover — Exhaust port shipping (for B5 only)	1
	513								Nut — Plain $\frac{1}{2}$ Hexagon head x $\frac{5}{16}$ -24 thd x $\frac{3}{8}$ in. thick (exhaust port studs)	27
	818								Palnut — .500 in. Hexagon head x .3125-24 PD (exhaust port studs)	27

REAR CASE

Figure Number	Part Number	1	2	3	4	5	6	7	Nomenclature	Units Per Assy
	48564								Case Assembly Complete — Rear (for AN engines using NA-R9B carburetors)	1
	48565								Case Assembly Complete — Rear (for AN engines using NA-R9C2 carburetors)	1
	114377								Case Assembly Complete — Rear (for B3 & B5 engines using NA-R9B carburetors)	1
	114378								Case Assembly Complete — Rear (for B3 & B5 engines using NA-R9C2 carburetors)	1
	123724								Case Assembly Complete — Rear (replaces No. 123547; for B4 with oil seals)	1
9, 10	126299								Case & Studs Assembly — Rear (for AN engines using NA-R9B carburetors; <i>supersedes No. 47554</i>)	1
9, 10	151882								Case & Studs Assembly — Rear (for AN engines using NA-R9C2 carburetors; <i>supersedes No. 47616</i>)	1
9, 10	126301								Case & Studs Assembly — Rear (for B3 & B5 engines using NA-R9B carburetors; <i>supersedes No. 45948 & 114380</i>)	1
9, 10	126302								Case & Studs Assembly — Rear (for B3 & B5 engines using NA-R9C2 carburetors; <i>supersedes No. 45949 & 114381</i>)	1
	126304								Case & Studs Assembly — Rear (replaces No. 126305; for use with Part No. 123724 rear case & studs assembly; for B4 only)	1
	*57999								Case Machining Assembly — Rear (for all engines except B4)	1
	*121217								Case Machining Assembly — Rear (replaces No. 80496; for use with Part No. 123724 rear case & studs assembly; for B4 only)	1
	*39106								Case Casting Assembly — Rear (for all engines except B4)	1
	*121216								Case Casting Assembly — Rear (for use with Part No. 123724 case & studs assembly; for B4 only)	1
	*80495								Case Casting Assembly — Rear (for use with Part No. 123547 rear case & studs assembly; for B4 only)	1
	136								Plug — Hexagon socket .750 ANPT x .500 in. long Special (rear crankcase)	3
	129								Plug — Hexagon socket .250 in. ANPT (rear crankcase)	2
	10897								Pipe — Oil pressure rear crankcase	1
	57852								Pin — Straight .0985 dia x .740 in. long (pressure pipe fastens rear crankcase; <i>supersedes No. 30</i>)	1
	138								Plug — Hexagon socket .125 in. ANPT (rear case; for B4 only)	1
	†1171								Bushing — Gun control	2
	1171+3								Bushing same as 1171 only .003 in. oversize	
	1171+5								Bushing same as 1171 only .005 in. oversize	
	1171+10								Bushing same as 1171 only .010 in. oversize	
	1171+15								Bushing same as 1171 only .015 in. oversize	
	1171+20								Bushing same as 1171 only .020 in. oversize	
10	†10682								Bushing — Flanged 3/8-18 ID x 3/4-14 OD x 7/8 in. long (pipe reducing)	1
	10682+10								Bushing same as 10682 only .010 in. oversize	
	25								Pin — Straight .165 dia x .500 in. long (fastens Part No. 1171 bushing)	2
	2075								Tube — Tachometer drive oil	2
	24929								Screw — Flat fillister head 1/4-20 thd x 7/16 in. long (rear case)	2
10	11521								Plug — Hexagon socket .125 in. ANPT (rear case; use (8) units for B4)	9
	17346								Plug — .281 Square head x .125-27 Pipe x .578 in. long (rear case; use (4) units for B4)	5
	41514								Plug — .076 Square head x .750-14 Pipe x .962 in. long (gun drive left hand rear case; for B4 only)	1
10	19865								Plug — .438 Square head x .375-18 Pipe x .796 in. long (rear case pressure pipe hole)	1
	28834								Dowel — Straight .128 dia x .312 in. long (vacuum pump adapter locating)	1
9, 10	†11051								Dowel — Straight .312 dia x .500 in. long (magneto locating)	4
	11051+2								Dowel same as 11051 only .002 in. oversize	
	62								Dowel — Straight .250 dia x .625 in. long (oil pump locating)	1
	28								Pin — Straight .072 dia x .312 in. long (magneto oil shield; for use with magnetos not having lip type oil seal)	2
10	19865								Plug — .438 Square head x .375-18 Pipe x .796 in. long (rear case oil)	1
9	3649								Plate — Vane discharge	1

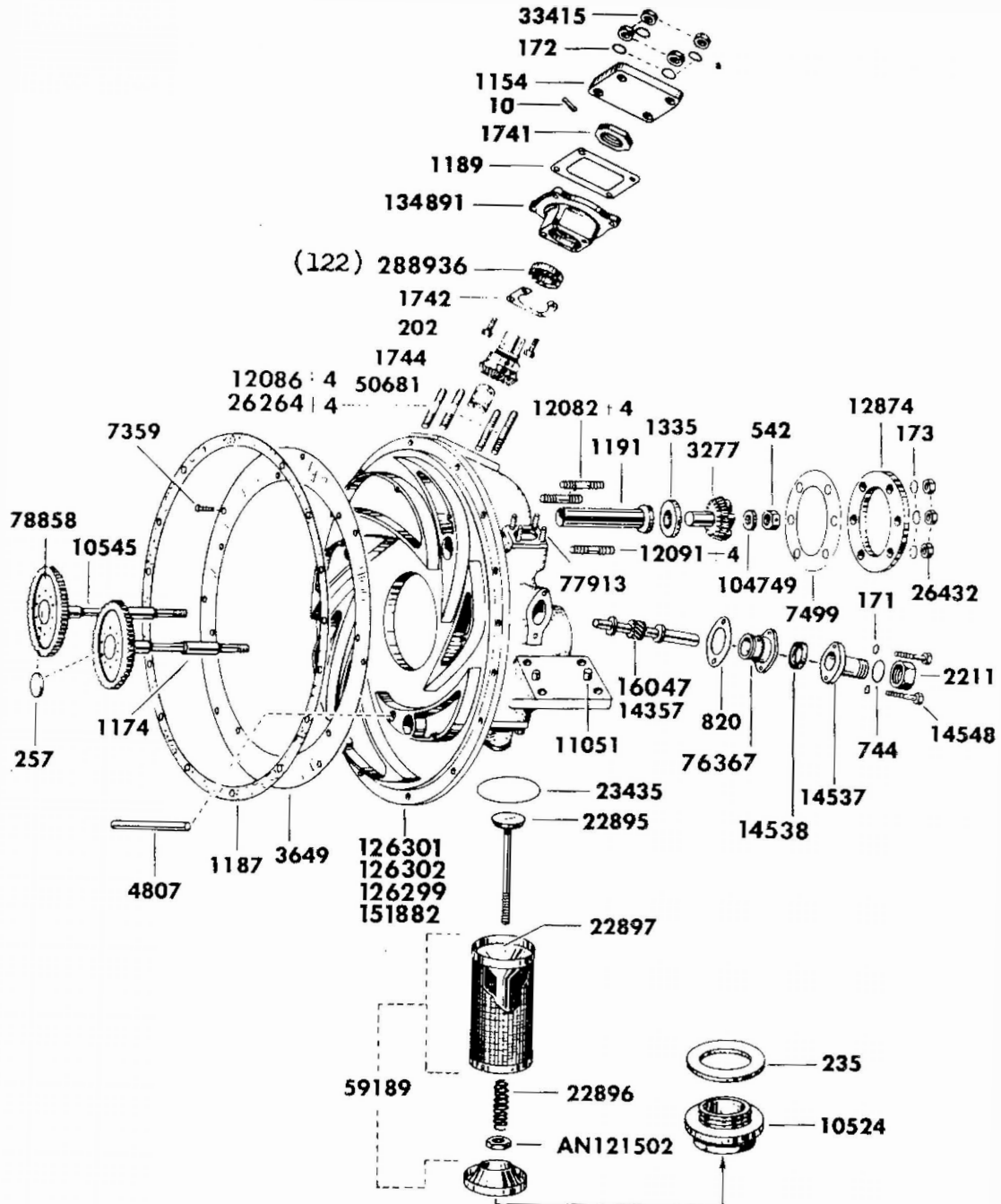

Figure 9. Rear Case

International AeroTech Academy For Training Purpose Only

REAR CASE

Figure Number	Part Number	1	2	3	4	5	6	7	Nomenclature	Units Per Assy
9	7359								Screw — Flat head No. 10-32 thd x 1/2 in. long (vane discharge plate; <i>supersedes</i> No. 214)	7
	138								Plug — Hexagon socket .125 in. ANPT (oil strainer inspection hole)	1
10	†656+4								Stud — Plain .3125-18-24 thd x 1.625 in. long (fuel pump) .004 in. oversize	4
	656+8								Stud same as 656 only .008 in. oversize	
	656+12								Stud same as 656 only .012 in. oversize	
10	†23299+4								Stud — Plain .3125-18-24 thd x 3.125 in. long (oil pump) .004 in. oversize	2
	23299+8								Stud same as 23299 only .008 in. oversize	
	23299+12								Stud same as 23299 only .012 in. oversize	
10	†19868+4								Stud — Plain .3125-18-24 thd x 2.375 in. long (oil pump) .004 in. oversize	4
	19868+8								Stud same as 19868 only .008 in. oversize	
	19868+12								Stud same as 19868 only .012 in. oversize	
9	†12082+4								Stud — Plain .375-16-24 thd x 1.531 in. long (starter) .004 in. oversize	2
	12082+8								Stud same as 12082 only .008 in. oversize	
	12082+12								Stud same as 12082 only .012 in. oversize	
9	†12091+4								Stud — Plain .375-16-24 thd x 1.781 in. long (starter) .004 in. oversize	4
	12091+8								Stud same as 12091 only .008 in. oversize	
	12091+12								Stud same as 12091 only .012 in. oversize	
10	†12317+4								Stud — Plain .3125-18-24 thd x 1.312 in. long (oil pipe connections; <i>supersedes</i> No. 12054) .004 in. oversize	6
	12317+8								Stud same as 12317 only .008 in. oversize	
	12317+12								Stud same as 12317 only .012 in. oversize	
	†43613								Stud — Drilled 1/4-20-28 thd x 1.250 in. long (governor pad; use with Part No. 502 nut)	8
	43613+4								Stud same as 43613 only .004 in. oversize	
	43613+8								Stud same as 43613 only .008 in. oversize	
	43613+12								Stud same as 43613 only .012 in. oversize	
9, 10	†77913								Stud — Plain 1/4-20-28 thd x 1.380 in. long (gun synchronizer; <i>supersedes</i> No. 43613; for B3 & B5 only; use (4) unit on the left hand side for AN & B4 engines; use with Part No. 12856 & 214219 nut)	8
	77913+4								Stud same as 77913 only .004 in. oversize	
	77913+8								Stud same as 77913 only .008 in. oversize	
	77913+12								Stud same as 77913 only .012 in. oversize	
10	†5206+4								Stud — Drilled .250-20-28 thd x 2.578 in. long (gun synchronizer right hand; for AN engines only) .004 in. oversize	4
	5206+8								Stud same as 5206 only .008 in. oversize	
	5206+12								Stud same as 5206 only .012 in. oversize	
10	†626+4								Stud — Drilled .3125-18-24 thd x 1.500 in. long (carburetor adapter) .004 in. oversize	2
	626+8								Stud same as 626 only .008 in. oversize	
	626+12								Stud same as 626 only .012 in. oversize	
	626+62								Stud same as 626 only .062 in. oversize	
	†658+4								Stud — Plain .3125-18-24 thd x 1.938 in. long (carburetor adapter; for engines using NA-R9C2 carburetors) .004 in. oversize	2
	658+8								Stud same as 658 only .008 in. oversize	
	658+12								Stud same as 658 only .012 in. oversize	
	†40180+4								Stud — Plain .3125-18-24 thd x 1.516 in. long (carburetor bracket; for engines using NA-R9C2 carburetors) .004 in. oversize	1
	40180+8								Stud same as 40180 only .008 in. oversize	
	40180+12								Stud same as 40180 only .012 in. oversize	
10	†11345+4								Stud — Plain .3125-18-24 thd x 1.562 in. long (carburetor adapter; for engines using NA-R9B carburetors; use (2) units for engines using NA-R9C2 carburetors) .004 in. oversize	4
	11345+8								Stud same as 11345 only .008 in. oversize	
	11345+12								Stud same as 11345 only .012 in. oversize	

REAR CASE

Figure Number	Part Number	1	2	3	4	5	6	7	Nomenclature	Units Per Assy
9	†26264+4								Stud — Drilled .3125-18-24 thd x 1.781 in. long (generator; for AN engines) .004 in. oversize	4
	26264+8								Stud same as 26264 only .008 in. oversize	
	26264+12								Stud same as 26264 only .012 in. oversize	
9	†12086+4								Stud — Plain .3125-18-24 thd x 2.000 in. long (generator; for B3 & B5 only) .004 in. oversize	4
	12086+8								Stud same as 12086 only .008 in. oversize	
	12086+12								Stud same as 12086 only .012 in. oversize	
	†9085+4								Stud — Plain .3125-18-24 thd x 1.375 in. long (generator; for B4 only) .004 in. oversize	4
	9085+8								Stud same as 9085 only .008 in. oversize	
	9085+12								Stud same as 9085 only .012 in. oversize	
	†123423+4								Stud — Plain .250-20-28 thd x 1.750 in. long (vacuum pump; <i>supersedes</i> No. 35142) .004 in. oversize	4
	123423+8								Stud same as 123423 only .008 in. oversize	
	123423+12								Stud same as 123423 only .012 in. oversize	
	46256								Gasket — 1.05 ID x 1.6 OD x .015 in. thick (swivel fitting; for all engines except B4)	2
10	46253								Fitting — .750 in. NPT (swivel; for all engines except B4)	2
10	46254								Support — Swivel fitting (for all engines except B4)	2
10	48139								Gasket — .90 ID x 1.500 OD x .015 in. thick (swivel fitting nut; for all engines except B4)	2
10	46255								Plug — 1½ Hexagon head x 7/8-14 thd x 1¼ in. long (swivel fitting; for all engines except B4)	2
10	†10682								Bushing — Flanged 5/8-18 ID x 3/4-14 OD x 7/8 in. long (pipe reducing swivel fitting; for all engines except B4)	2
	10682+10								Bushing same as 10682 only .010 in. oversize	
10	19865								Plug — .438 Square head x .375-18 Pipe x .796 in. long (swivel fitting; for all engines except B4)	2
	74963								Elbow — Rear oil scavenge pipe to case (for B4 only)	1
	74957								Pipe Assembly — Rear oil scavenge (for B4 only)	1
	827								Gasket — .688 ID Pipe flanged x .031 in. thick (rear oil scavenge; for B4 only)	1
	33415								Nut — Fibre insert 5/16-24 thd x 23/64 in. thick (rear oil scavenge pipe flange, for B4 only)	2
	34079								Clamp Assembly — 1.125 ID Hose (cylinder head oil drain; for B4 only)	3
	158188								Screw — Cylinder head oil drain clamp	1
	158189								Nut — Fibre .190-24 thd x .266 in. thick Special (cylinder head oil drain clamp screw)	1
	59739								Tee — Pipe hose — Cylinder head oil drain No. 7 & 8 (for B4 only)	1
	74956								Pipe Assembly — Cylinder head oil drain (for B4 only)	1
9	†1191								Bushing — Starter shaft	1
	1191+2								Bushing same as 1191 only .002 in. oversize	
	1191+3								Bushing same as 1191 only .003 in. oversize	
	1191+5								Bushing same as 1191 only .005 in. oversize	
	1191+10								Bushing same as 1191 only .010 in. oversize	
	1191+15								Bushing same as 1191 only .015 in. oversize	
	1191+20								Bushing same as 1191 only .020 in. oversize	
	1191+30								Bushing same as 1191 only .030 in. oversize	
	1191+40								Bushing same as 1191 only .040 in. oversize	
	†121207								Spacer — Starter bushing oil (for use with Part No. 123724 rear case & studs assembly; for B4 only)	1
	121207+2								Spacer same as 121207 only .002 in. oversize	
	121207+3								Spacer same as 121207 only .003 in. oversize	
	121207+5								Spacer same as 121207 only .005 in. oversize	
	121207+10								Spacer same as 121207 only .010 in. oversize	
	121207+15								Spacer same as 121207 only .015 in. oversize	

REAR CASE

Figure Number	Part Number	1	2	3	4	5	6	7	Nomenclature	Units Per Assy
	121207+20								Spacer same as 121207 only .020 in. oversize	
	121207+30								Spacer same as 121207 only .030 in. oversize	
	28955								Seal — 1.156 ID x .125 in. thick (starter bushing oil: for use with Part No. 123724 rear case & studs assembly; for B4 only)	1
9	†1174								Bushing — Magneto drive shaft long	2
	1174+2								Bushing same as 1174 only .002 in. oversize	
	1174+3								Bushing same as 1174 only .003 in. oversize	
	1174+5								Bushing same as 1174 only .005 in. oversize	
	1174+10								Bushing same as 1174 only .010 in. oversize	
	1174+15								Bushing same as 1174 only .015 in. oversize	
	1174+20								Bushing same as 1174 only .020 in. oversize	
	1174+30								Bushing same as 1174 only .030 in. oversize	
	1174+40								Bushing same as 1174 only .040 in. oversize	
	†121208								Spacer — Magneto bushing oil (for use with Part No. 123724 rear case & studs assembly; for B4 only)	2
	121208+2								Spacer same as 121208 only .002 in. oversize	
	121208+3								Spacer same as 121208 only .003 in. oversize	
	121208+5								Spacer same as 121208 only .005 in. oversize	
	121208+10								Spacer same as 121208 only .010 in. oversize	
	121208+15								Spacer same as 121208 only .015 in. oversize	
	121208+20								Spacer same as 121208 only .020 in. oversize	
	121208+30								Spacer same as 121208 only .030 in. oversize	
	36090								Seal — .750 ID x .125 in. thick (magneto bushing oil: for use with Part No. 123724 rear case & studs assembly; for B4 only)	2
9	†4807								Tube — Rear to collector case oil pressure	1
	4807+10								Tube same as 4807 only .010 in. oversize	
	4807+20								Tube same as 4807 only .020 in. oversize	
	4807+30								Tube same as 4807 only .030 in. oversize	
	4807+40								Tube same as 4807 only .040 in. oversize	
	4807+50								Tube same as 4807 only .050 in. oversize	
	†121209								Spacer — Oil pressure tube oil (for use with Part No. 123724 rear case & studs assembly; for B4 only)	1
	121209+10								Spacer same as 121209 only .010 in. oversize	
	121209+20								Spacer same as 121209 only .020 in. oversize	
	44076								Seal — .438 ID x .125 in. thick (oil pressure tube oil: for use with Part No. 123724 rear case & studs assembly; for B4 only)	1
	25820								Gasket — Carburetor ell cover (for AN engines only)	1
	25821								Cover — Carburetor ell (for AN engines only)	1
	44107								Screw — Fillister head drilled 1/4-20 thd x 7/16 in. long (carburetor ell cover: use AS 100029 wire; for AN engines only)	3
	234								Gasket — .625 ID x .938 OD x .078 in. thick (carburetor ell cover plug; for AN engines only)	1
	131								Plug — Round head 5/16-18 thd x 9/16 in. long (carburetor ell cover; for AN engines only)	1
10	6262								Cover — Carburetor ell (for B3, B4 & B5 only)	1
10	171								Washer — Plain 1/16 ID x 1/2 OD x 1/16 in. thick (carburetor ell cover screws; for B3, B4 & B5 only)	3
10	6263								Screw — Fillister head drilled 1/4-20 thd x 7/16 in. long (carburetor ell cover: use No. AS 100029 wire; for B3, B4 & B5 only)	3
8	6191								Gasket — .812 ID Pipe flanged x .031 in. thick (rear oil drain; for all engines except B4)	2
8	9598								Pipe Assembly — Oil drain rear (for all engines except B4)	1
	33415								Nut — Fibre insert 3/16-24 thd x 23/64 in. thick (rear oil drain pipe; use (2) units for B4)	4
	†15443								Plug — Plain slotted 5/16-18 thd x 1/4 in. long (rear case)	2
	15443+4								Plug same as 15443 only .004 in. oversize	
	12094								Washer — Plain 23/64 ID x 11/16 OD x 3/32 in. thick (rear case to collector)	16
	33415								Nut — Fibre insert 3/16-24 thd x 23/64 in. thick (rear case to collector)	15
	12009								Nut — Plain 1/2 Hexagon head x 3/16-24 thd x 13/64 in. thick (rear case to collector)	1
	818								Palnut — .500 in. Hexagon head x .3125-24 PD (rear case to collector)	1

OIL PUMP AND PRESSURE RELIEF VALVE

Figure Number	Part Number	1	2	3	4	5	6	7	Nomenclature	Units Per Assy
10	17009								Gasket — Rear oil pump to rear case	1
	38366								Pump Assembly Complete — Oil (<i>supersedes No. 47563</i>)	1
10	86266								Pump Machining Assembly — Oil (<i>supersedes No. 38365</i>)	1
	*38360								Body — Oil pressure pump	1
	*38361								Body — Oil suction pump	1
	*38362								Body — Oil pump suction	1
	*1579								Plate — Oil pump end	1
10	38368								Bolt — $\frac{7}{16}$ Slotted hexagon head x $\frac{1}{4}$ -28 thd x $3\frac{1}{2}$ in. long (oil pump)	4
10	502								Nut — Castled .438 Hexagon head x .250-28 NF-3 thd x .282 in. thick (oil pump bolt; <i>use No. AS 100029 wire</i>)	4
10	†12317+4								Stud — Plain .3125-18-24 thd x 1.312 in. long (oil suction pump; <i>supersedes No. 12054</i>) .004 in. oversize	2
	12317+8								Stud same as 12317 only .008 in. oversize	
	12317+12								Stud same as 12317 only .012 in. oversize	
10	†12317+4								Stud — Plain .3125-18-24 thd x 1.312 in. long (oil inlet connection) .004 in. oversize	2
	12317+8								Stud same as 12317 only .008 in. oversize	
	12317+12								Stud same as 12317 only .012 in oversize	
	†314047								Ring — Oil seal .093 ID x 3.216 OD x .101 in. thick (oil pump; <i>supersedes No. 8138</i>)	1
	314047+5								Ring same as 314047 only .005 in. oversize	
	314047+10								Ring same as 314047 only .010 in. oversize	
	314047+10W								Ring same as 314047 only .010 in. oversize on Width	
	314047R1								Ring same as 314047 only .005 in. oversize on OD and .010 in oversize on Width	
	314047R2								Ring same as 314047 only .010 in. oversize on OD and .010 in oversize on Width	
	38367								Gear & Shaft Assembly — Oil pump idler	1
10	38364								Shaft — Oil pump idler	1
10	8735								Gear — Drilled hole .561 dia x 1.2485 in. long (idler oil suction pump)	1
10	AN 122696								Pin — Dowel, steel .1250 dia x .875 in. long (oil pump idler gear to shaft; <i>supersedes No. 37</i>)	1
10	149								Plug — Disc .625 dia x .064 in. long (oil pump)	1
10	10110								Gear — Drilled hole .561 dia x .3755 in. long (idler oil suction rockerbox)	1
10	1428								Gear — Drilled hole .561 dia x .9355 in. long (idler oil pressure pump)	1
10	38363								Gear — Oil pump drive	1
10	†224883								Key — Flat .125 x .150 x $\frac{3}{4}$ in. long (oil suction pump gear; <i>supersedes No. 87</i>)	1
	224883+2								Key same as 224883 only .002 in. oversize	
	224883+5								Key same as 224883 only .005 in. oversize	
	224883+10								Key same as 224883 only .010 in. oversize	
	224883+20								Key same as 224883 only .020 in. oversize	
	224883+20S								Key — Stepped same as 224883 only .020 in. oversize	
	224883+30								Key same as 224883 only .030 in. oversize	
	224883+30S								Key — Stepped same as 224883 only .030 in. oversize	
	224883+40S								Key — Stepped same as 224883 only .040 in. oversize	
	224883+50S								Key — Stepped same as 224883 only .050 in. oversize	
	224883+60S								Key — Stepped same as 224883 only .060 in. oversize	
10	8734								Gear — Keyed .561 dia x 1.2485 in. long (oil suction pump)	1
10	†224884								Key — Flat .1275 x .141 x .312 in. long (oil suction pump; <i>supersedes No. 10128</i>)	1
	224884+2								Key same as 224884 only .002 in. oversize	
	224884+5								Key same as 224884 only .005 in. oversize	
	224884+10								Key same as 224884 only .010 in. oversize	
	224884+20								Key same as 224884 only .020 in. oversize	
	224884+20S								Key — Stepped same as 224884 only .020 in. oversize	
	224884+30								Key same as 224884 only .030 in. oversize	
	224884+30S								Key — Stepped same as 224884 only .030 in. oversize	
	224884+40S								Key — Stepped same as 224884 only .040 in. oversize	
	224884+50S								Key — Stepped same as 224884 only .050 in. oversize	
	224884+60S								Key — Stepped same as 224884 only .060 in. oversize	

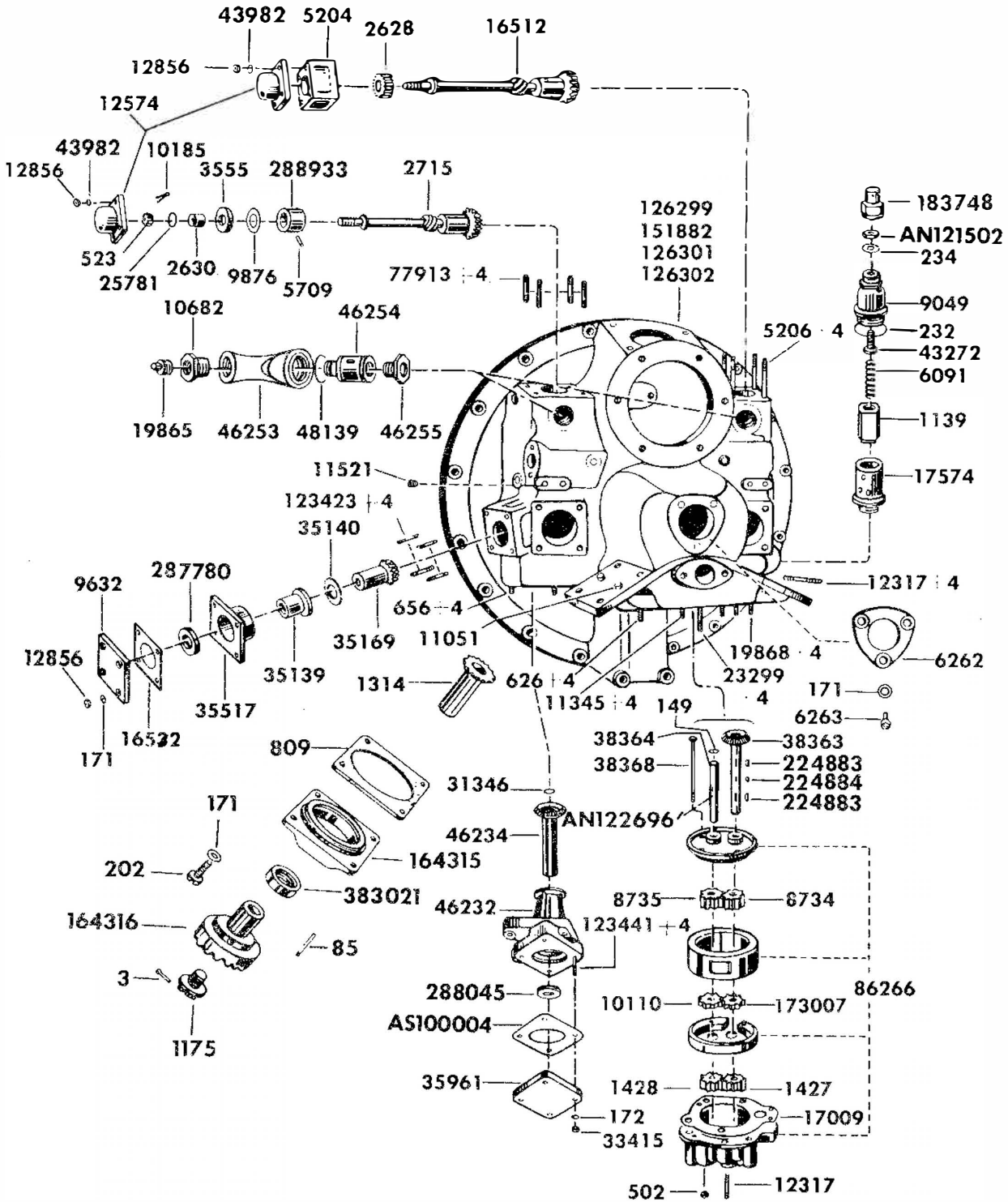

Figure 10. Oil Pump and Pressure Relief Valve

OIL PUMP AND PRESSURE RELIEF VALVE

Figure Number	Part Number	Nomenclature							Units Per Assy
		1	2	3	4	5	6	7	
10	173007	Gear — Oil suction rockerbox (<i>supersedes No. 10129</i>)							1
10	†224883	Key — Flat .125 x .150 x 3/4 in. long (oil pressure pump gear; <i>supersedes No. 87</i>)							1
	224883+2	Key same as 224883 only .002 in. oversize							
	224883+5	Key same as 224883 only .005 in. oversize							
	224883+10	Key same as 224883 only .010 in. oversize							
	224883+20	Key same as 224883 only .020 in. oversize							
	224883+20S	Key — Stepped same as 224883 only .020 in. oversize							
	224883+30	Key same as 224883 only .030 in. oversize							
	224883+30S	Key — Stepped same as 224883 only .030 in. oversize							
	224883+40S	Key — Stepped same as 224883 only .040 in. oversize							
	224883+50S	Key — Stepped same as 224883 only .050 in. oversize							
	224883+60S	Key — Stepped same as 224883 only .060 in. oversize							
10	1427	Gear — Keyed .561 dia x .9355 in. long (oil pressure pump)							1
	24250	Packing — 1 1/32 ID x 3/8 OD x 5/32 in. thick (oil pump body; <i>supersedes No. 71972</i>)							2
	132	Plug — Disc .625 dia x .064 in. long (oil pump)							2
	172	Washer — Plain 2 1/64 ID x 3/16 OD x 1/16 in. thick (oil pump)							6
	33415	Nut — Fibre insert 5/16-24 thd x 2 3/4 in. thick (oil pump)							5
	519	Nut — Slotted 5/16 x .24 in. thick Special (oil pump)							1
10	17374	Body — Oil pressure relief valve							1
10	1139	Plunger — Oil pressure relief valve							1
10	6091	Spring — Oil pressure relief valve							1
10	232	Gasket — 1.1325 ID x .125 Wall x .094 in. thick (oil pressure relief valve housing to rear case; <i>supersedes No. 236</i>)							1
10	9049	Housing — Oil pressure relief valve							1
10	43272	Screw — Oil pressure relief valve adjusting							1
10	AN 121502	Nut — Plain .250-28 thd x .219 in. thick (locks Part No. 43272 screw; <i>supersedes No. 501</i>)							1
10	234	Gasket — .625 ID x .938 OD x .078 in. thick (oil pressure relief valve cap)							1
10	183748	Cap — .625-18 NS thd (oil pressure relief valve; use No. AS 100029 wire; <i>supersedes No. 8699</i>)							1
9	59189	Screen Assembly — Oil (<i>supersedes No. 22545</i>)							1
	25978	Valve & Seat Assembly — Oil return check							1
9	22897	Seat — Oil return check valve							1
9	22896	Spring — .559 OD x .038 in. dia Wire (oil return check valve)							1
9	22895	Valve — Oil return check							1
9	AN 121502	Nut — Plain .250-28 thd x .219 in. thick (oil return check valve; <i>supersedes No. 501</i>)							1
9	23435	Seal — 1.688 ID x .141 in. thick (oil return check valve)							1
9	235	Gasket — 2.575 ID x 2.750 OD x .094 in. thick (oil screen cover)							1
9	10524	Cover — Oil screen							1
10	234	Gasket — .625 ID x .938 OD x .078 in. thick (oil thermometer hole plug)							1
	131	Plug — Round head 5/8-18 thd x 3/16 in. long (oil thermometer hole)							1
	6924	Gasket — .703 ID x .938 OD x .078 in. thick (oil pressure hole plug)							1
	13404	Plug — Oil pressure hole to right of vacuum pump drive pad (use No. AS 100029 wire)							1
	84106	Gasket — Oil inlet & outlet connections (for shipping only; use Part No. 11042 gasket for engine operation)							1
	33858	Cover — Oil connection shipping							2
	33415	Nut — Fibre insert 5/16-24 thd x 2 3/4 in. thick (oil connection shipping cover)							1
	84623	Pipe Assembly — Oil thermostat connection (optional equipment)							1
	11042	Gasket — 1.016 ID Pipe flanged x .016 in. thick (oil inlet connection)							1
	11045	Pipe Assembly — Oil thermometer connection							1
10	234	Gasket — .625 ID x .938 OD x .078 in. thick (oil inlet plug)							1
	131	Plug — Round head 5/8-18 thd x 3/16 in. long (oil inlet connection; use No. AS 100029 wire)							1
	33415	Nut — Fibre insert 5/16-24 thd x 2 3/4 in. thick (oil inlet cover)							1
	12398	Bolt — Plain .500 Hexagon head x .3125-24 thd x .953 in. long (oil inlet cover)							1

STARTER DRIVE

Figure Number	Part Number	1	2	3	4	5	6	7	Nomenclature	Units Per Assy
8	288932								Bearing Option — Starter gear (procurement number consists of: Part No. 104 Bearing — Ball 1.1811 ID x 2.4409 OD x .6229 in. long (optional to Part No. 288900 or 359231) Part No. 288900 Bearing — Ball 1.1811 ID x 2.4409 OD x .6229 in. Wide (optional to Part No. 104 or 359231) Part No. 359231 Bearing — Ball 1.1811 ID x 2.4409 OD x .6229 in. Wide (optional to Part No. 104 or 288900)	1
8, 9	1335								Spacer — Starter gear	1
8	3278								Gear — Starter	1
	3277								Jaw — Starter (for installations requiring a three tooth jaw; for use with Part No. 135054 housing & shaftgear assembly generator drive)	1
	17090								Jaw — Starter (for installations requiring a three tooth jaw: for use with Part No. 120645 strengthened housing & shaftgear assembly generator drive; for AN-1, -3, -14B & B5 only)	1
	24040								Jaw — Starter (for installations requiring a twelve tooth jaw)	1
9	104749								Washer — Plain .516 ID x 1.188 OD x .125 in. thick (starter shaft; <i>supersedes No. 184</i>)	1
9	542								Nut — 3/4 Slotted hexagon head x 1/2-20 thd x 2 1/64 in. thick (starter shaft)	1
	AS 123791								Cotterpin — .086-.090 dia x .750 in. long (starter shaft nut; P&W Part No. 11359)	1
9	7499								Gasket — Starter cover	1
9	12874								Cover — Accessory pad (<i>supersedes No. 70964</i>)	1
9	173								Washer — Plain 25/64 ID x 1 1/16 OD x 1/16 in. thick (accessory pad cover)	6
9	26432								Nut — Fibre insert 3/8-24 thd x 25/64 in. thick (accessory pad cover)	6

GENERATOR DRIVE

	31123								Seal — 2.500 ID x 2.542 OD x .021 in. thick (generator drive; for all engines except B4)	1
	135054								Housing & Shaftgear Assembly — Generator drive (for all engines except B4 having old generator drives; <i>supersedes No. 1899</i>)	1
	120645								Housing & Shaftgear Assembly — Generator drive (for AN-1, -3, -14B & B5 having strengthened generator drive)	1
	119528								Housing and Shaftgear Assembly — Generator drive (optional to Part No. 120645 generator drive; for B5 only)	1
9	134891								Housing — Generator drive (for use with Part No. 135054 housing assembly; for all engines except B4; <i>supersedes No. 28626</i>)	1
	119527								Housing — Generator drive (for use with Part No. 120645 or 119528 housing assembly; for AN-1, -3, 14B & B5 only)	1
9	1742								Plate — Generator outboard bearing (for all engines except B4)	1
9	202								Screw — Fillister head drilled .250-20 NC thd x .562 in. long (generator outboard bearing plate: use <i>No. AS 100029 wire</i> ; for all engines except B4)	4
9	288936								Bearing Option — Generator pinion (for use with Part No. 120645 or 119528: use (1) unit with Part No. 135054: for all engines except B4; procurement number consists of: Part No. 122 Bearing — Ball 1.1811 ID x 2.4409 OD x .3037 in. long (optional to Part No. 288904 or 359233) Part No. 288904 Bearing — Ball 1.1811 ID x 2.4409 OD x .3037 in. Wide (optional to Part No. 122 or 359233) Part No. 359233 Bearing — Ball 1.1811 ID x 2.4409 OD x .3037 in. Wide (optional to Part No. 122 or 288904)	2
9	1744								Pinion — Generator drive (for use with Part No. 135054 housing assembly; for all engines except B4)	1

GENERATOR DRIVE

Figure Number	Part Number	Nomenclature							Units Per Assy
		1	2	3	4	5	6	7	
	17091	Pinion — Generator drive (for use with Part No. 120645 housing assembly; for AN-1, -3, -14B & B5 only)							1
9	50681	Cork — Generator drive pinion (for all engines except B4; <i>supersedes No. 7435</i>)							1
9	1741	Spannernut — $1\frac{3}{16}$ -12 PD x $1\frac{9}{16}$ x $\frac{1}{4}$ in. thick (generator outboard bearing: for use with Part No. 135054 housing assembly; for all engines except B4)							1
	18746	Nut — Spanner $1\frac{3}{16}$ -12 PD x $1\frac{9}{16}$ x $\frac{1}{4}$ in. thick (generator outboard bearing: for use with Part No. 120645 housing assembly; for AN-1, -3, -14B & B5 only)							1
9	10	Cotterpin — .058-.061 dia x .500 in. long (generator outboard bearing nut: for use with Part No. 135054 housing assembly; for all engines except B4)							1
	17088	Tabwasher — 1.203 ID x 1.438 OD x .058 in. thick (generator drive: for use with Part No. 120645 housing assembly; for AN-1, -3, -14B & B5)							1
	17089	Spacer — Generator drive (for use with Part No. 120645 housing assembly; for AN-1, -3, -14B & B5 only)							1
	119525	Shaftgear — Generator drive (for use with Part No. 119528 housing assembly; for B5 only)							1
	119526	Jaw — Generator drive, gear and starter (for use with Part No. 119528 housing assembly; for B5 only)							1
9	1189	Gasket — Generator drive cover (<i>supersedes No. 84108</i>)							1
9	1154	Cover — Generator drive (<i>supersedes No. 79514</i>)							1
9	172	Washer — Plain $2\frac{1}{16}$ ID x $9\frac{1}{16}$ OD x $\frac{1}{16}$ in. thick (generator drive cover)							4
9	33415	Nut — Fibre insert $3\frac{1}{16}$ -24 thd x $2\frac{3}{16}$ in. thick (generator drive cover)							4

TACHOMETER AND GUN DRIVE

Figure Number	Part Number	Nomenclature							Units Per Assy
		1	2	3	4	5	6	7	
9	16047	Gear Assembly — Tachometer drive (for AN engines only)							2
9	14357	Gear Assembly — Tachometer drive (for B3 & B5 only; use (1) unit for B4)							2
	*14604	Gear — Tachometer drive (for AN engines only)							1
	*14356	Gear — Tachometer drive (for B3, B4 & B5 only)							1
	1177	Insert — Tachometer drive gear							1
9	820	Gasket — .981 ID Pipe flanged x .016 in. thick (tachometer flange)							2
	2146	Tube — Tachometer drive oil plug right hand (for B4 only)							1
	2147	Cover — Tachometer drive right hand (for B4 only)							1
	11590	Coupling — Tachometer right hand (for B3 & B5 only)							1
	13028	Coupling — Tachometer left hand (for B3, B4 & B5 only)							1
9	76367	Coupling Assembly — Tachometer inner (for AN engines only)							2
	76365	Coupling — Tachometer (for AN engines only)							1
	76366	Bearing — Flanged .490 ID x .626 OD x .592 in. long (tachometer coupling; for AN engines only)							1
	43567	Pin — Straight .072 dia x .125 in. long (tachometer inner; for AN engines only)							1
9	287788	Seal Option — Tachometer drive (procurement number consists of: Part No. 14538 Seal — Oil (optional to Part No. 287778) Part No. 287778 Seal — Oil (optional to Part No. 14538)							2
9	14537	Coupling — Tachometer rear half (for AN engines only)							2
9	171	Washer — Plain $1\frac{7}{16}$ ID x $\frac{1}{2}$ OD x $\frac{1}{16}$ in. thick (tachometer coupling)							4
9	14548	Screw — Fillister head drilled $\frac{1}{4}$ -20 thd x $1\frac{13}{32}$ in. long (tachometer coupling: <i>use No. AS 100029 wire</i> ; for AN engines only)							4
	202	Screw — Fillister head drilled $\frac{1}{4}$ -20 thd x $9\frac{1}{16}$ in. long (tachometer coupling: <i>use No. AS 100029 wire</i> ; for B3, B4 & B5 only)							4
9	744	Gasket — $\frac{5}{16}$ ID x .688 OD x .078 in. thick (tachometer coupling; use (1) unit for B4)							2
9	2211	Cap — Tachometer coupling (use (1) unit for B4)							2
10	2715	Gear Assembly — Gun control (use (1) unit for AN engines)							2
	*2627	Shaft — Gun control tachometer drive gear							1

TACHOMETER AND GUN DRIVE

Figure Number	Part Number	1	2	3	4	5	6	7	Nomenclature	Units Per Assy
	17038								Plug — Tachometer drive oil distributor	1
10	5709								Pin — Straight .0949 dia x 1.031 in. long (tachometer drive oil distributor)	1
10	16512								Gear Assembly — Gun synchronizer drive (for AN engines only)	1
	*5205								Shaft — Gun control tachometer drive gear (for AN engines only)	1
	17038								Plug — Tachometer drive oil distributor (for AN engines only)	1
10	5709								Pin — Straight .0949 dia x 1.031 in. long (tachometer drive oil distributor; for AN engines only)	1
10	5204								Adapter — Gun synchronizer housing (for AN engines only)	1
10	2630								Liner — Gun synchronizer bearing	2
10	288933								Bearing Option — Gun control shaft (procurement number consists of: Part No. 109 Bearing — Ball .5906 ID x 1.3780 OD x .4331 in. long (optional to Part No. 288901 or 359233) Part No. 288901 Bearing — Ball .5906 ID x 1.3780 OD x .4331 in. Wide (optional to Part No. 109 or 359232) Part No. 359232 Bearing — Ball .5906 ID x 1.3780 OD x .4331 in. Wide (optional to Part No. 109 or 288901)	2
10	3555								Spacer — $\frac{37}{64}$ ID x $\frac{25}{32}$ OD x $\frac{9}{16}$ in. thick (gun control shaft; use (1) for AN-4, -6, -6B, -10, -12, -12B & -14B)	2
10	9876								Washer — Plain $\frac{25}{64}$ ID x $\frac{3}{4}$ OD x $\frac{3}{32}$ in. thick (gun drive; use (1) unit for AN-4, -6, -6B, -10, -12, -12B & -14B)	2
10	25781								Washer — Plain $\frac{25}{64}$ ID x $\frac{5}{8}$ OD x $\frac{3}{32}$ in. thick (gun drive right hand; for all engines except AN-1, -3, B3, B4 & B5)	1
10	523								Nut — Shear .562 Hexagon head x .375-24 thd x .328 in. thick (gun drive; <i>supersedes No. 23212</i>)	2
10	2628								Gear — Gun drive right hand (for all engines except AN-1, -3, B3, B4 & B5)	1
10	10185								Cotterpin — .072-.076 dia x .750 in. long (gun drive)	2
10	12574								Cover — Gun drive	2
	43982								Spacer — .266 ID x .500 OD x .234 in. thick (gun drive cover; use (4) units for AN engines)	8
10	171								Washer — Plain $\frac{17}{64}$ ID x $\frac{1}{2}$ OD x $\frac{1}{16}$ in. thick (gun drive cover; for AN engines only)	4
10	12856								Nut — Fibre insert $\frac{1}{4}$ -28 thd x $\frac{5}{16}$ in. thick (gun drive cover; for use with plain studs)	8
	214214								Nut — Nylon insert $\frac{1}{4}$ -28 x $\frac{5}{16}$ in. thick (gun drive cover: for use with plain or drilled studs; optional to Part No. 12856 nut)	8

MAGNETO DRIVE

Figure Number	Part Number	1	2	3	4	5	6	7	Nomenclature	Units Per Assy
9	10545								Shaft Assembly — Magneto drive	2
	10538								Shaft — Magneto drive	1
9	257								Plug — Welch .875 in. dia (magneto drive shaft)	1
	10502								Gear — Magneto drive	1
9	78858								Rivet — Flat head .186 dia x .375 in. long (magneto drive gear; <i>supersedes No. 151</i>)	6
10	†85								Key — Flat $\frac{3}{16}$ x $\frac{3}{32}$ x $1\frac{3}{32}$ in. long (fuel pump & gun control drive gear)	2
	85+2								Key same as 85 only .002 in. oversize	
10	1314								Gear — Fuel pump & gun control drive	2
	1108								Shield — Magneto drive oil (for use with magnetos not having lip type oil seal)	2
	981								Spring — 1.020 OD x .041 dia Wire x .205 in. long Free length compression (packing adjusting; for use with magnetos not having lip type oil seal)	2
10	809								Gasket — 2½ in. Square (magneto drive cover)	2
10	164315								Housing — Magneto drive oil seal (for use with magnetos having lip type oil seal)	2
10	383021								Seal — Oil .875 ID x 1.754 OD x .250 in. Wide (magneto housing: for use with magnetos having lip type oil seal; <i>supersedes No. 164314</i>)	2

MAGNETO DRIVE

Figure Number	Part Number	Nomenclature							Units Per Assy	
		1	2	3	4	5	6	7		
	1482								Cover Assembly — Magneto drive (for use with magnetos not having lip type oil seal)	2
	11468								Packing — Magneto shaft (for use with magnetos not having lip type oil seal)	1
	2383								Cover — Magneto drive (for use with magnetos not having lip type oil seal)	1
	1093								Washer — Magneto shaft packing (for use with magnetos not having lip type oil seal)	1
	153								Rivet — Round head .095 dia x .375 in. long (magneto drive cover; for use with magnetos not having lip type oil seal)	6
	175147								Rivet — Universal head .095 dia x .375 in. long (for service procurement; for use with magnetos not having lip type oil seal)	12
10	171								Washer — Plain $\frac{17}{64}$ ID x $\frac{1}{2}$ OD x $\frac{1}{16}$ in. thick (magneto drive cover)	8
10	202								Screw — Fillister head drilled $\frac{1}{4}$ -20 thd x $\frac{3}{16}$ in. long (magneto drive cover; use No. AS 100029 wire)	8
10	164316								Coupling — Magneto drive (for use with magnetos having lip type oil seal)	2
	11049								Gear — Magneto drive coupling (for use with magnetos not having lip type oil seal)	2
10	1175								Screw — $\frac{7}{16}$ -20 thd x $\frac{13}{16}$ in. long (magneto drive shaft)	2
10	3								Cotterpin — .072-.076 dia x 1.500 in. long (magneto drive shaft screws)	2

VACUUM PUMP DRIVE

Figure Number	Part Number	Nomenclature							Units Per Assy	
		1	2	3	4	5	6	7		
	9633								Gasket — Vacuum pump drive	1
	37907								Gear Assembly — Vacuum pump drive	1
10	35517								Adapter Assembly — Vacuum pump splined drive	1
	*35138								Adapter — Vacuum pump splined drive	1
10	35139								Bushing — Flanged .865 ID x 1.033 OD x .859 in. long (vacuum pump splined drive)	1
10	35140								Spacer — .875 ID x 1.438 OD x .109 in. thick (vacuum pump gear)	1
10	35169								Gear — Vacuum pump splined drive	1
10	287780								Seal — Oil .875 ID x 1.379 ID x .375 in. thick (vacuum pump gear; replaces No. 30684; supersedes No. 287792)	1
10	16532								Gasket — .0016 in. thick (accessory pad vacuum pump drive cover)	1
10	9632								Cover — Vacuum pump drive	1
10	171								Washer — Plain $\frac{17}{64}$ ID x $\frac{1}{2}$ OD x $\frac{1}{16}$ in. thick (vacuum pump drive cover; use (4) units with plain studs)	8
10	12856								Nut — Fibre insert $\frac{1}{4}$ -28 thd x $\frac{5}{16}$ in. thick (vacuum pump drive cover; for use with plain studs)	4

FUEL PUMP DRIVE

Figure Number	Part Number	Nomenclature							Units Per Assy	
		1	2	3	4	5	6	7		
	34637								Gasket — Fuel pump & lubrication drive bracket	1
	123596								Bracket Assembly — Fuel pump drive gear (supersedes No. 46235)	1
10	46232								Bracket — Fuel pump drive gear	1
10	†123441+4								Stud — Drilled .3125-18-24 thd x 1.562 in. long (fuel pump; supersedes No. 37812) .004 in. oversize	4
	123441+8								Stud same as 123441 only .008 in. oversize	
	123441+12								Stud same as 123441 only .012 in. oversize	
10	288045								Seal — Oil .750 ID x 1.379 OD x .312 in. Wide (fuel pump drive shaft; supersedes No. 37819)	1

FUEL PUMP DRIVE

Figure Number	Part Number	1	2	3	4	5	6	7	Nomenclature	Units Per Assy
10	172								Washer — Plain $\frac{21}{64}$ ID x $\frac{9}{16}$ OD x $\frac{1}{16}$ in. thick (fuel pump drive bracket)	4
10	33415								Nut — Fibre insert $\frac{5}{16}$ -24 thd x $\frac{23}{64}$ in. thick (fuel pump drive bracket)	4
10	46234								Gear Assembly — Fuel pump drive	1
	*46233								Gear — Fuel pump drive	1
10	31346								Plug — Welch .593 in. dia (fuel pump drive gear)	1
10	AS 100004								Gasket — Fuel pump drive cover (<i>supersedes No. 21099 or 77908</i>)	1
10	35961								Cover — .375 in. thick (accessory pad; fuel pump drive; <i>supersedes No. 77907</i>)	1
10	172								Washer — Plain $\frac{21}{64}$ ID x $\frac{9}{16}$ OD x $\frac{1}{16}$ in. thick (fuel pump drive cover)	4
10	33415								Nut — Fibre insert $\frac{5}{16}$ -24 thd x $\frac{23}{64}$ in. thick (fuel pump drive cover; for use with plain studs)	4

GUN SYNCHRONIZER — (OPTIONAL EQUIPMENT)

Figure Number	Part Number	1	2	3	4	5	6	7	Nomenclature	Units Per Assy
	24116								Generator Assembly — 35° Gun synchronizer right hand	1
	24117								Generator Assembly — 35° Gun synchronizer left hand	1
11	7916								Cotterpin — .072-.076 dia x .500 in. long (gun synchronizer; <i>supersedes No. 11754</i>)	1
11	69								Dowel — Shouldered .1405-.1415 dia x .188 in. long (gun synchronizer)	1
11	70								Dowel — Straight .1875 dia x .688 in. long (gun synchronizer)	2
11	288933								Bearing Option — Gun synchronizer (procurement number consists of: Part No. 109 Bearing — Ball .5906 ID x 1.3780 OD x .4331 in. long (optional to Part No. 288901 or 359232) Part No. 288901 Bearing — Ball .5906 ID x 1.3780 OD x .4331 in. long (optional to Part No. 109 or 359232) Part No. 359232 Bearing — Ball .5906 ID x 1.3780 OD x .4331 in. Wide (optional to Part No. 109 or 288901)	2
11	722								Washer — Plain $\frac{17}{64}$ ID x $\frac{25}{32}$ OD x $\frac{1}{16}$ in. thick (gun synchronizer)	1
11	220								Screw — Fillister head No. 8-32 thd x $\frac{1}{4}$ in. long (gun synchronizer; <i>use No. AS 100029 wire</i>)	2
11	242								Gasket — Inspection port	1
11	171								Washer — Plain $\frac{17}{64}$ ID x $\frac{1}{2}$ OD x $\frac{1}{16}$ in. thick (gun synchronizer)	4
11	285								Screw — Fillister head drilled $\frac{1}{4}$ -20 thd x $\frac{23}{32}$ in. long (gun synchronizer)	4
11	502								Nut — Castled $\frac{7}{16}$ Hexagon head x $\frac{1}{4}$ -28 thd x $\frac{9}{32}$ in. thick (gun synchronizer)	1
11	1921								Plate — Inspection port	1
11	2032								Cap — Cam plunger	1
11	744								Gasket — $\frac{5}{16}$ ID x .688 OD x .078 in. thick (gun synchronizer)	1
11	39171								Plug — Cam plunger lock	1
11	5199								Housing — Right hand gun synchronizer	1
11	5198								Housing — Left hand gun synchronizer	1
11	2631								Cam — 35° Angle (magnetic gun control)	1
11	2634								Shim — Cam adjusting	1
11	39133								Cover — Gun synchronizer	1
11	2636								Bolt — Cam special (gun synchronizer gear)	1
11	2651								Retainer — Bearing & cam gear	1
11	8288								Follower Assembly — Gun synchronizer	1
11	208								Screw — Round head No. 8-32 thd x $\frac{1}{4}$ in. long (gun synchronizer)	2
11	10941								Plate — Data	1
11	70489								Washer — Plain .781 ID x 1.00 OD x .031 in. thick (gun synchronizer)	1

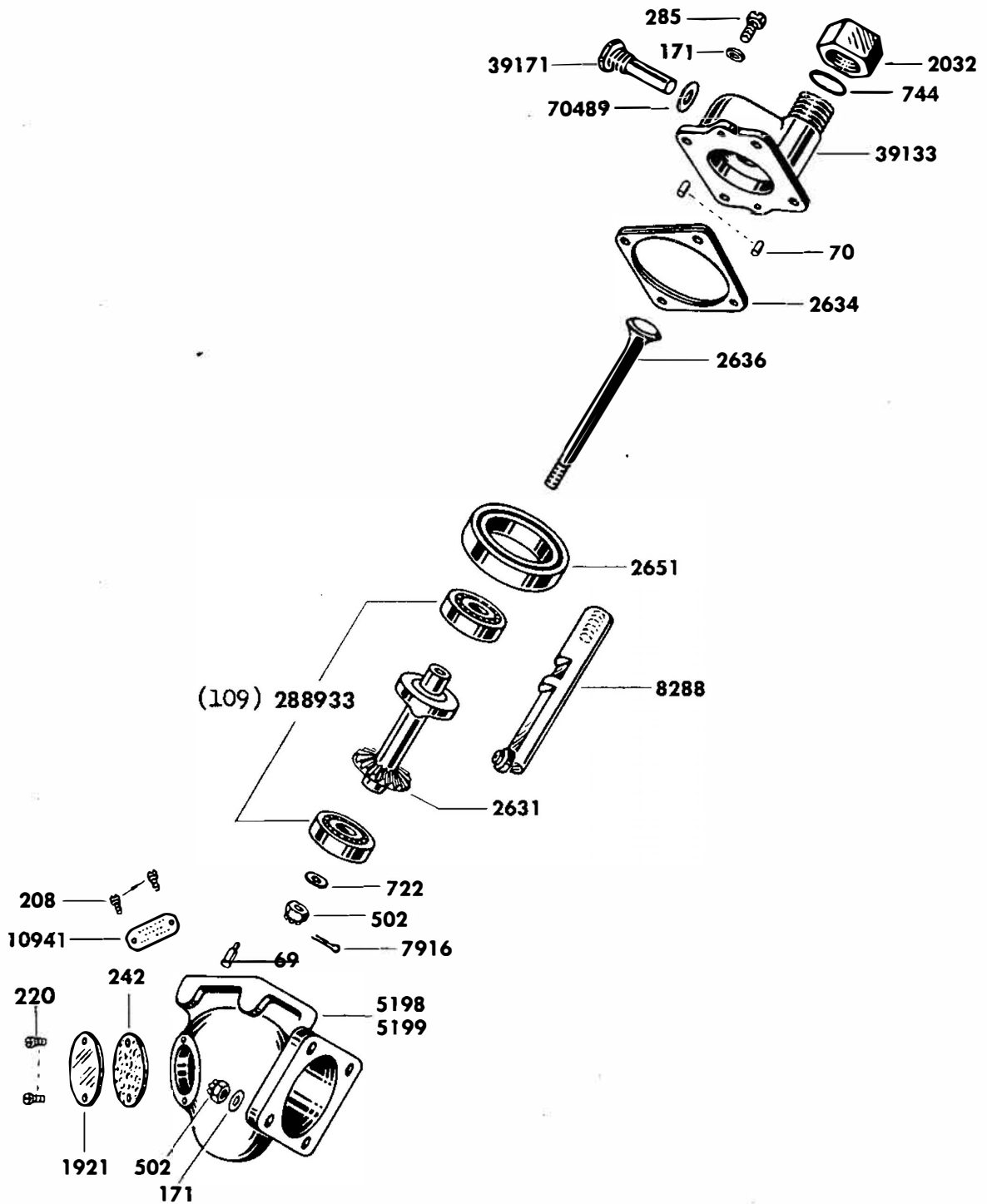

Figure 11. Gun Synchronizer — (Optional Equipment)

CYLINDER PRIMING SYSTEM

Figure Number	Part Number	1	2	3	4	5	6	7	Nomenclature	Units Per Assy
	45936								Connections Assembly — Primer	1
12	27205								Tubing Complete — Cylinder No. 1 primer	1
12	27206								Tubing Complete — Cylinder No. 2 primer	1
12	27207								Tubing Complete — Cylinder No. 3 primer	1
12	27208								Tubing Complete — Cylinder No. 8 primer	1
12	26508								Tubing Complete — Cylinder No. 9 primer	1
12	48776								Clamp Assembly — Primer tubing to intake pipes	10
12	8650								Screw — Round head No. 6-32 thd x 1 in. long (primer tubing to intake pipe clamps)	10
12	23930								Clip — Cylinders No. 3 & 8 (primer tubing to ignition manifold)	2
12	23000								Screw — Round head No. 8-36 thd x 1/2 in. long (cylinders No. 3 & 8; primer tubing clips; <i>supersedes No. 42016</i>)	2
12	11747								Nut — Fibre insert No. 8-36 thd x 15/64 in. thick (cylinders No. 3 & 8; primer tubing clip screws)	2
12	20229								Elbow Assembly — 1/8 in. Tubing (primer fuel; cylinder end of primer tubing)	5
	100186								Distributor Assembly — Engine primer	1
12	27210								Distributor — Engine primer	1
12	4220								Washer — Plain 1 3/64 ID x 3/8 OD x 3/64 in. thick (primer distributor to cylinder No. 1 intake pipe screws; <i>supersedes No. 11751</i>)	2
12	20228								Screw — Fillister head No. 10-24 thd x 1.500 in. long (primer distributor to cylinder No. 1 intake pipe; <i>use No. AS 100029 wire</i>)	2
12	5509								Nipple — Union .125-27 ANPT x .125 in. dia Tube (distributor end of primer tubing)	5
12	17346								Plug — .281 Square head x .125-27 Pipe x .578 in. long (unused holes in primer distributor; <i>use No. AS 100029 wire</i>)	4
	53723								Tag — Breather opening warning	1
	55753								Tag — Notice — To outside of plioilm bag	1

IGNITION SYSTEM

BOSCH MAGNETOS ARE NO LONGER AVAILABLE FROM THE MANUFACTURER. CUSTOMERS REQUIRING MAGNETOS MUST ORDER THE SCINTILLA MAGNETO LISTED IN THE TEXT BELOW. WHEN USING SCINTILLA MAGNETOS WITH IGNITION HARNESSES ORIGINALLY USING BOSCH MAGNETOS IT IS NECESSARY TO REWIRE THE ENTIRE HARNESS AS THE DISTRIBUTOR BLOCKS ARE MOUNTED AT DIFFERENT ANGLES.

Figure Number	Part Number	1	2	3	4	5	6	7	Nomenclature	Units Per Assy
13	165376								Cable Assembly — Radio shielded ignition front (for use with Scintilla magnetos SB9RN-4; <i>supersedes No. 90461 & 90480</i>)	1
	113811								Cable Assembly — Radio shielded ignition front (for use with Scintilla magnetos SB9RN; has plain brass sparkplug elbows & full length ceramic sparkplug connectors)	1
	84462								Cable Assembly — Radio shielded ignition front (for use with Bosch magnetos; has cadmium plated sparkplug elbows & inland neoprene & ceramic sparkplug connectors)	1
	47131								Cable Assembly — Radio shielded ignition front (for use with Bosch magnetos; has cadmium plated sparkplug elbows & full length ceramic sparkplug connectors)	1
	39650								Cable Assembly — Radio shielded ignition front (for use with Scintilla magnetos & has non-detachable sparkplug elbows; for B3 only)	1
13	33688								Manifold — Front ignition harness	1
13	39377								Plate — Ignition harness data (detail of assembly No. 84462)	1
	231626								Plate — Ignition manifold data (detail of assemblies No. 113811, 165376, 47131)	1
13	123790								Cable — Special purpose electrical ignition 7 m/m (detail of all assemblies except No. 90461; <i>supersedes No. 37141</i> ; use as required)	1
	96121								Cable — Special purpose electrical ignition 5 m/m (detail of assembly No. 90461; use as required)	1

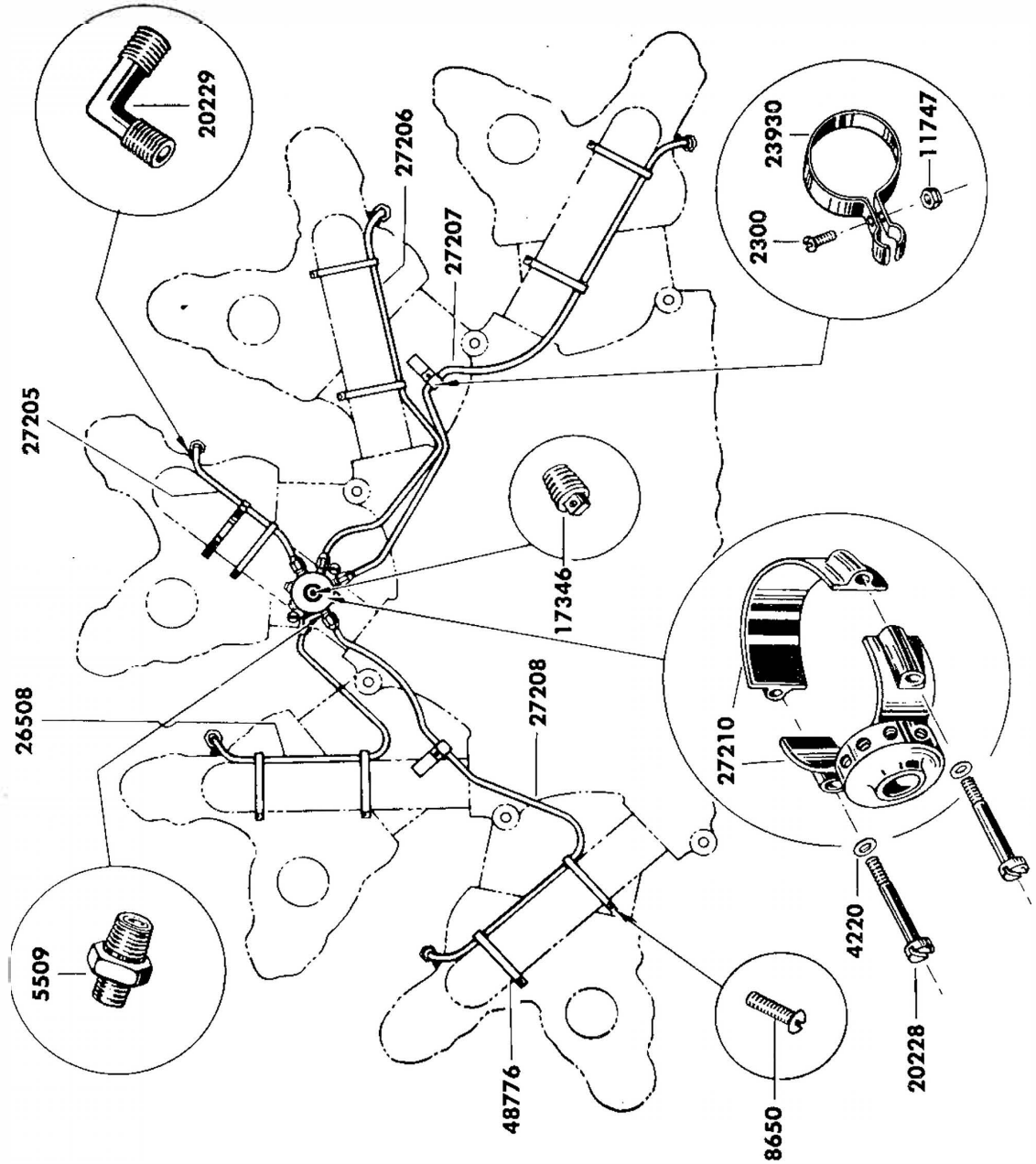

Figure 12. Cylinder Priming System

IGNITION SYSTEM

Figure Number	Part Number	Nomenclature							Units Per Assy
		1	2	3	4	5	6	7	
	32383	Grommet — 7 m/m Sparkplug lead at manifold outlet (detail of all assemblies except No. 90461)							9
	96347	Grommet — .503-.513 OD x .550 in. long (5 m/m sparkplug lead at manifold outlet; detail of assembly No. 90461)							9
13	92367	Conduit Assembly — Manifold to sparkplug (detail of all assemblies except No. 39650)							9
13	92370	Conduit — Flexible .320 ID x .500 in. OD (manifold to sparkplug)							7 in.
13	92368	Nut — .745-.755 Hexagon head x .438 in. thick (sparkplug conduit coupling)							2
13	92369	Ferrule — .521-.527 ID x .630-.635 OD x .310 in. long (sparkplug conduit)							2
	34587	Conduit Assembly — Manifold to sparkplug (detail of assembly No. 39650)							9
	29894	Conduit — Flexible $2\frac{1}{16}$ ID x $\frac{7}{16}$ in. OD (manifold to sparkplug)							6 in.
	29593	Washer — Plain .311 ID x .459 OD x $\frac{3}{32}$ in. thick (sparkplug conduit)							1
	29941	Elbow — Sparkplug							1
	29893	Nut — Sparkplug conduit coupling							1
	29407	Ferrule — .459 ID x .531 OD x $1\frac{1}{16}$ in. long (sparkplug conduit)							1
	38674	Grommet — Sparkplug elbow (for 7 m/m cable; detail of all assemblies except No. 90461 & 39650)							9
	96125	Grommet — .345-.355 ID x .200-.206 in. long (sparkplug elbow; for 5 m/m cable; detail of assembly No. 90461)							9
13	185956	Elbow — Sparkplug (detail of assembly No. 113811, 90480, 90461, 165376, 84462 & 47131; <i>supersedes</i> No. 92366 & 78643)							9
	96122	Packing — For inside of sparkplug elbow when using 5 m/m cable (detail of assembly No. 90461)							9
	59482	Collar — Sparkplug elbow waterproof (detail of assembly No. 84462)							9
13	82307	Connector — Sparkplug full length ceramic (detail of assembly No. 113811, 90480, 47131 & 165376)							9
	304914	Contact Option — Sparkplug neoprene & ceramic (detail of assemblies No. 90461 or 84462; procurement number consists of: Part No. 59477 Contact — (optional to Part No. 304911) Part No. 304911 Contact — (optional to Part No. 59477)							9
	29783	Connector — Sparkplug yellow bakelite (detail of assembly No. 39650)							9
13	54364	Cap — .625-24-NS-1 in. (sparkplug connector protecting; detail of all assemblies except No. 39650)							9
	54363	Cap — .5625-27-NS-1 in. (sparkplug connector protecting; detail of assembly No. 39650)							9
13	90437	Conduit Assembly — Front ignition manifold to magneto (detail of assembly No. 113811, 90480, 90461 & 165376)							1
	*362612	Conduit — Front ignition manifold to magneto (<i>supersedes</i> No. 33692)							22 in.
	*88708	Nut — Magneto conduit coupling							2
	*231623	Ferrule — Magneto conduit (<i>supersedes</i> No. 32370)							2
13	231627	Clamp Assembly Complete — Magneto conduit to rear ignition manifold (<i>supersedes</i> No. 35091)							1
	231628	Clamp Assembly — Magneto conduit (<i>supersedes</i> No. 37123)							1
	12079	Screw — Round head No. 10-32 thd x $\frac{3}{4}$ in. long (magneto conduit clamp)							1
	11748	Nut — Fibre insert No. 10-32 thd x $1\frac{1}{16}$ in. thick (magneto conduit clamp screw)							1
	33694	Conduit Assembly — Front ignition manifold to magneto (detail of all assemblies except No. 113811, 90480, 90461 & 165376)							1
	*362612	Conduit — Front ignition manifold to magneto (<i>supersedes</i> No. 33692)							22 in.
	*231623	Ferrule — Coupling nut (<i>supersedes</i> No. 32370)							1
	*256309	Nut — Coupling							1
13	231627	Clamp Assembly Complete — Magneto conduit to rear ignition manifold (<i>supersedes</i> No. 35091)							1
	231628	Clamp Assembly — Magneto conduit (<i>supersedes</i> No. 37123)							1
	12079	Screw — Round head No. 10-32 thd x $\frac{3}{4}$ in. long (magneto conduit clamp)							1

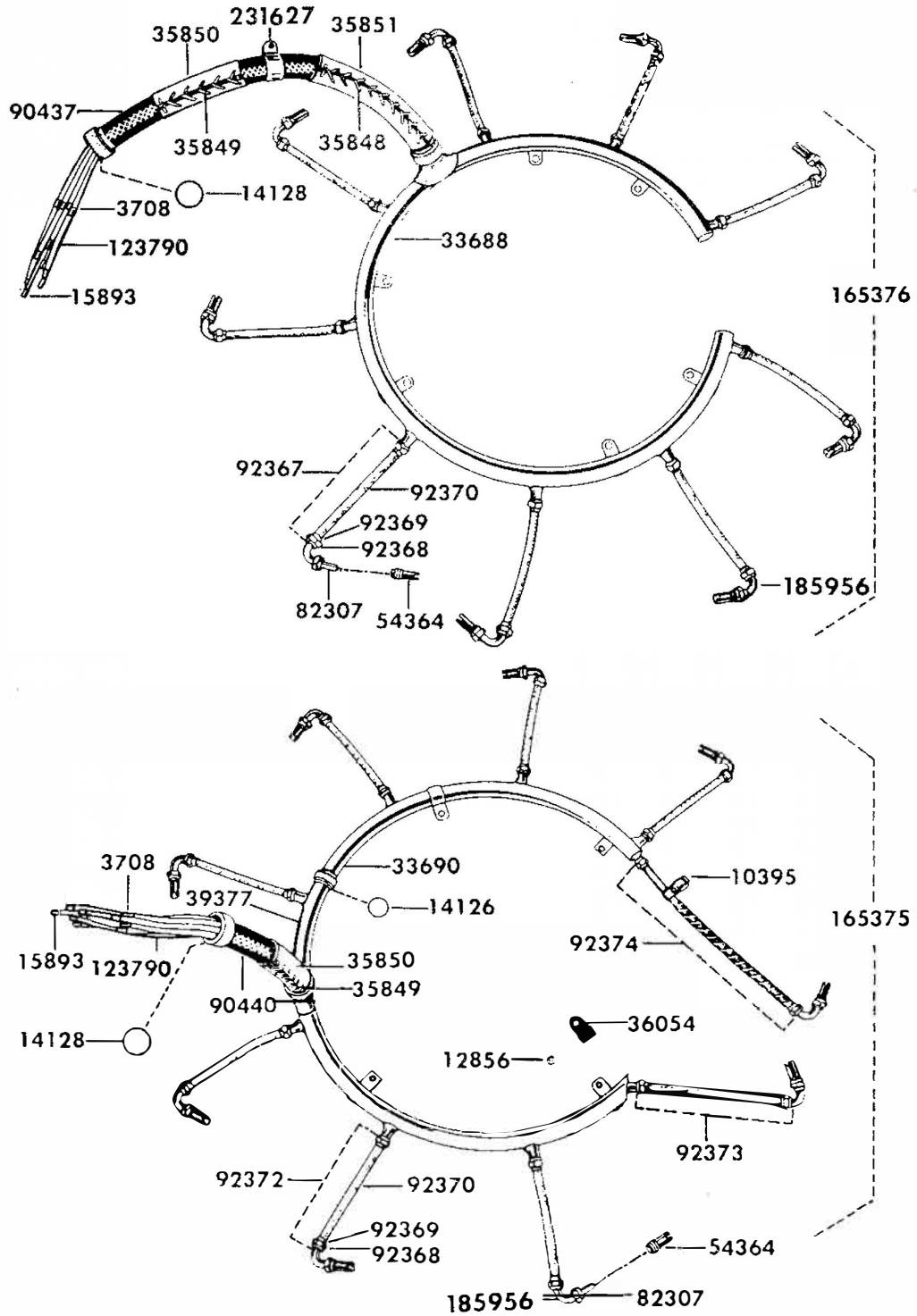

Figure 13. Ignition System

IGNITION SYSTEM

Figure Number	Part Number	1	2	3	4	5	6	7	Nomenclature	Units Per Assy
	11748								Nut — Fibre insert No. 10-32 thd x $1\frac{5}{16}$ in. thick (magneto conduit clamp screw)	1
	99953								Tube — .253-.273 ID x 14.875-15.125 in. long (5 m/m ignition cable protecting inside magneto conduit; detail of assembly No. 90461)	9
13	3708								Marker — Ignition cable (detail of all assemblies except No. 39650)	9
13	14128								Gasket — 1.422 ID x 1.562 OD x .031 in. thick (manifold to magneto conduit coupling nut)	1
	96124								Sleeve — .200-.208 ID x 2.500 in. long (magneto end of 5 m/m sparkplug cable waterproof; detail of assembly No. 90461)	9
13	15893								Ferrule — .292 ID x .312 OD x .500 in. long (magneto end of 7 m/m ignition cable; detail of all assemblies except No. 90461)	9
	47266								Ferrule — .292 ID x .312 OD x .375 in. long (magneto end of 5 m/m ignition cable; detail of assembly No. 90461)	9
13	35851								Guard — Magneto conduit	1
13	35848								Lacing — Magneto conduit guard	1
13	35850								Guard — Magneto conduit	1
13	35849								Lacing — Magneto conduit guard	1
13	165375								Cable Assembly — Radio shielded ignition rear (for use with Scintilla magnetos SB9RN-4; supersedes No. 90456 & 90481)	1
	113812								Cable Assembly — Radio shielded ignition rear (for use with Scintilla magnetos SB9RN; has plain brass sparkplug elbows & full length ceramic sparkplug connectors)	1
	84463								Cable Assembly — Radio shielded ignition rear (for use with Bosch magnetos; has cadmium plated sparkplug elbows & inland neoprene & ceramic sparkplug connectors)	1
	47132								Cable Assembly — Radio shielded ignition rear (for use with Bosch magnetos; has cadmium plated sparkplug elbows & full length ceramic sparkplug connectors)	1
	39649								Cable Assembly — Radio shielded ignition rear (for use with Scintilla magnetos & has non-detachable sparkplug elbows; for B3 only)	1
13	33690								Manifold — Rear ignition harness	1
13	14126								Gasket — 1.000 ID x 1.188 OD x .078 in. thick (rear ignition manifold sections coupling nut)	1
13	39377								Plate — Ignition harness data (detail of assembly No. 84463)	1
	231626								Plate — Ignition manifold data (detail of assemblies 113812, 165375 or 47132)	1
13	123790								Cable — Special purpose electrical ignition 7 m/m (detail of all assemblies except No. 90456; supersedes No. 37141; use as required)	
	96121								Cable — Special purpose electrical ignition 5 m/m (detail of assembly No. 90456; use as required)	
	32383								Grommet — 7 m/m Sparkplug lead at manifold outlet (detail of all assemblies except No. 90456)	9
	96347								Grommet — .503-.513 OD x .550 in. long (5 m/m sparkplug lead at manifold outlet; detail of assembly No. 90456)	9
13	92372								Conduit Assembly — Manifold to sparkplug (cylinders No. 1, 2, 3, 4, 7, 8 & 9; detail of all assemblies except No. 39649)	7
13	92370								Conduit — Flexible .320 ID x .500 in. OD (manifold to sparkplug)	7 in.
13	92368								Nut — .745-.755 Hexagon head x .438 in. thick (sparkplug conduit coupling)	2
13	92369								Ferrule — .521-.527 ID x .630-.635 OD x .310 in. long (sparkplug conduit)	2
	34588								Conduit Assembly — Manifold to sparkplug (cylinders No. 1, 2, 3, 4, 7, 8 & 9; detail of assembly No. 39649)	7
	29894								Conduit — Flexible $2\frac{1}{16}$ ID x $7\frac{1}{16}$ in. OD (manifold to sparkplug)	6 in.
	29593								Washer — Plain .311 ID x .459 OD x $\frac{3}{32}$ in. thick (sparkplug conduit)	1
	29941								Elbow — Sparkplug	1
	29893								Nut — Sparkplug conduit coupling	1
	29407								Ferrule — .459 ID x .531 OD x $1\frac{3}{16}$ in. long (sparkplug conduit)	1
13	92373								Conduit Assembly — Manifold to sparkplug (cylinder No. 6; detail of all assemblies except No. 39649)	1
13	92370								Conduit — Flexible .320 ID x .500 in. OD (manifold to sparkplug)	9 in.
13	92368								Nut — .745-.755 Hexagon head x .438 in. thick (sparkplug conduit coupling)	2

IGNITION SYSTEM

Figure Number	Part Number	1	2	3	4	5	6	7	Nomenclature	Units Per Assy
13	92369								Ferrule — .521-.527 ID x .630-.635 OD x .310 in. long (sparkplug conduit)	2
	34585								Conduit Assembly — Manifold to sparkplug (cylinder No. 6; detail of assembly No. 39649)	1
	29894								Conduit — Flexible $2\frac{1}{4}$ ID x $\frac{7}{16}$ in. OD (manifold to sparkplug)	8 in.
	29593								Washer — Plain .311 ID x .459 OD x $\frac{3}{32}$ in. thick (sparkplug conduit)	1
	29355								Elbow — Sparkplug	1
	29893								Nut — Sparkplug conduit coupling	1
	29407								Ferrule — .459 ID x .531 OD x $1\frac{3}{16}$ in. long (sparkplug conduit)	1
13	92374								Conduit Assembly — Manifold to sparkplug (cylinder No. 5; detail of all assemblies except No. 39649)	1
13	92370								Conduit — Flexible .320 ID x .500 in. OD (manifold to sparkplug)	13 in.
13	92368								Nut — .745-.755 Hexagon head x .438 in. thick (sparkplug conduit coupling)	2
13	92369								Ferrule — .521-.527 ID x .630-.635 OD x .310 in. long (sparkplug conduit)	2
	33241								Conduit Assembly — Manifold to sparkplug (cylinder No. 5; detail of assembly No. 39649)	1
	29894								Conduit — Flexible $2\frac{1}{4}$ ID x $\frac{7}{16}$ in. OD (manifold to sparkplug)	12 in.
	29593								Washer — Plain .311 ID x .459 OD x $\frac{3}{32}$ in. thick (sparkplug conduit)	1
	29355								Elbow — Sparkplug	1
	29893								Nut — Sparkplug conduit coupling	1
	29407								Ferrule — .459 ID x .531 OD x $1\frac{3}{16}$ in. long (sparkplug conduit)	1
	38674								Grommet — Sparkplug elbow (for 7 m/m cable; detail of all assemblies except No. 90456 & 39649)	9
	96125								Grommet — .345-.355 ID x .200-.206 in. long (sparkplug elbow; for 5 m/m cable; detail of assembly No. 90456)	9
13	185956								Elbow — Sparkplug (detail of assembly No. 113812, 90481, 90456, 165375, 84463 & 47132; <i>supersedes</i> No. 92366 & 78643)	9
	96122								Packing — For inside of sparkplug elbow when using 5 m/m cable (detail of assembly No. 90456)	9
	59482								Collar — Sparkplug elbow waterproof (detail of assembly No. 84463)	9
13	82307								Connector — Sparkplug full length ceramic (detail of assembly No. 113812, 90481, 47132 & 165375)	9
	304914								Contact Option Sparkplug neoprene & ceramic (detail of assemblies No. 90456 & 84463; procurement number consists of: Part No. 59477 Contact — (optional to Part No. 304911) Part No. 304911 Contact — (optional to Part No. 59477)	9
	29783								Connector — Sparkplug yellow bakelite (detail of assembly No. 39649)	9
13	54364								Cap — .625-24-NS-1 in. (sparkplug connector protecting; detail of all assemblies except No. 39649)	9
	54363								Cap — .5625-27-NS-1 in. (sparkplug connector protecting; detail of assembly No. 39649)	9
13	90440								Conduit Assembly — Rear ignition manifold to magneto (detail of assembly No. 113812, 90481, 90456 & 165375)	1
	33695								Conduit Assembly — Rear ignition manifold to magneto (detail of all assemblies except No. 113812, 90481, 90456 & 165375)	1
	99953								Tube — .253-.273 ID x 14.875-15.125 in. long (5 m/m ignition cable protecting inside magneto conduit; detail of assembly No. 90456)	9
13	3708								Marker — Ignition cable (detail of all assemblies except No. 39649)	9
13	14128								Gasket — 1.422 ID x 1.562 OD x .031 in. thick (manifold to magneto conduit coupling nut)	1
	96124								Sleeve — .200-.208 ID x 2.500 in. long (magneto end of 5 m/m sparkplug cable waterproof; detail of assembly No. 90456)	9
13	15893								Ferrule — .292 ID x .312 OD x .500 in. long (magneto end of 7 m/m ignition cable; detail of all assemblies except No. 90456)	9
	47266								Ferrule — .292 ID x .312 OD x .375 in. long (magneto end of 5 m/m ignition cable; detail of assembly No. 90456)	9
13	35850								Guard — Magneto conduit	1

IGNITION SYSTEM

Figure Number	Part Number	1	2	3	4	5	6	7	Nomenclature	Units Per Assy
13	35849								Lacing — Magneto conduit guard	1
13	10395								Clip — No. 5 Sparkplug lead to suction pipe (detail of all assemblies except No. 39649)	1
	35013								Clamp Assembly — No. 5 sparkplug lead to suction pipe (detail of assembly No. 39649)	1
	35012								Clamp — No. 5 Sparkplug lead to suction pipe	1
	19727								Screw — Round head No. 8-36 thd x $\frac{5}{8}$ in. long (suction pipe clamp)	1
	11747								Nut — Fibre insert No. 8-36 thd x $\frac{15}{64}$ in. thick (suction pipe clamp screw)	1
13	36054								Brace Assembly — Ignition manifold to crankcase stud	4
13	12856								Nut — Fibre insert $\frac{1}{4}$ -28 thd x $\frac{5}{16}$ in. thick (ignition manifold to crankcase stud brace screw)	4
	127015								Neoprene Tape — (for service procurement)	40 ft.
	A-25696								Stud — Sparkplug connector (Titeflex; for service procurement)	18
	B-25697								Sleeve — Sparkplug barrel sealing (Titeflex; for service procurement)	18
	A-25695								Assemble Contact — Spring & retaining nut (Titeflex; for service procurement)	18
	A-22883								Sleeve Adapter — (Titeflex; for service procurement)	18

MAGNETO AND ATTACHING PARTS

Figure Number	Part Number	1	2	3	4	5	6	7	Nomenclature	Units Per Assy
14	24437								Magneto — SB9RN-4 (radio shielded fixed ignition right hand)	1
14	28853								Magneto — SB9RN-4 (radio shielded fixed ignition left hand)	1
	27962								Magneto & Gear Assembly — (for use with Scintilla magnetos SB9RN)	2
	27961								Magneto & Shield Assembly — (for use with Scintilla magnetos SB9RN)	1
14	27953								Magneto — Scintilla SB9RN	1
	5484								Shield Assembly — Magneto (Scintilla SB9RN)	1
14	5484-1								Shield — Magneto	1
14	5484-2								Shield — Magneto	1
14	245								Bolt — Plain .375 Hexagon head x No. 10-32 thd x .812 in. long (magneto shields attaching)	2
14	MS 122030								Washer — Lock, spring .194-.205 ID x .337 OD x .047-.053 in. thick (magneto shields attaching screw nuts; <i>supersedes</i> No. 726)	2
14	520								Nut — Plain $\frac{3}{8}$ Hexagon head x No. 10-32 thd x $\frac{3}{16}$ in. thick (magneto shields attaching screws)	2
14	7920								Lockwasher — .194-.205 ID x .337 OD x .047-.057 in. thick (magneto conduit elbow lock screw)	1
14	7921								Screw — Fillister head No. 10-24 thd x .373 in. long (magneto conduit elbow lock)	1
14	11048								Flange — Magneto coupling	1
14	11050								Washer — $\frac{25}{64}$ ID x $\frac{13}{16}$ OD x .172 in. thick (magneto coupling flange)	1
14	11052								Disc — Rubber magneto coupling	2
	173								Washer — Plain $\frac{25}{64}$ ID x $\frac{11}{16}$ OD x $\frac{1}{16}$ in. thick (magneto mounting)	6
	8756								Screw — $\frac{9}{16}$ Hexagon head drilled x $\frac{3}{8}$ -16 thd x 1 in. long (magneto mounting; <i>use</i> No. ASI00029 wire)	6
14	13089								Elbow Assembly — Right hand magneto conduit radio shielding (for use with Scintilla magnetos SB9RN)	1
	14319								Elbow — Right hand magneto conduit	1
	14320								Plug — $\frac{3}{4}$ Hexagon head x $\frac{11}{16}$ -24 x $\frac{11}{32}$ in. long (right hand magneto conduit elbow)	2
	14321								Coupling — High tension lead	1
	14322								Cap — $\frac{11}{16}$ -24 x $\frac{23}{32}$ in. OD (high tension lead coupling)	1
14	13090								Elbow Assembly — Left hand magneto conduit radio shielding (for use with Scintilla magnetos SB9RN)	1
	14319								Elbow — Left hand magneto conduit	1
	14320								Plug — $\frac{3}{4}$ Hexagon head x $\frac{11}{16}$ -24 x $\frac{11}{32}$ in. long (left hand magneto conduit elbow)	3

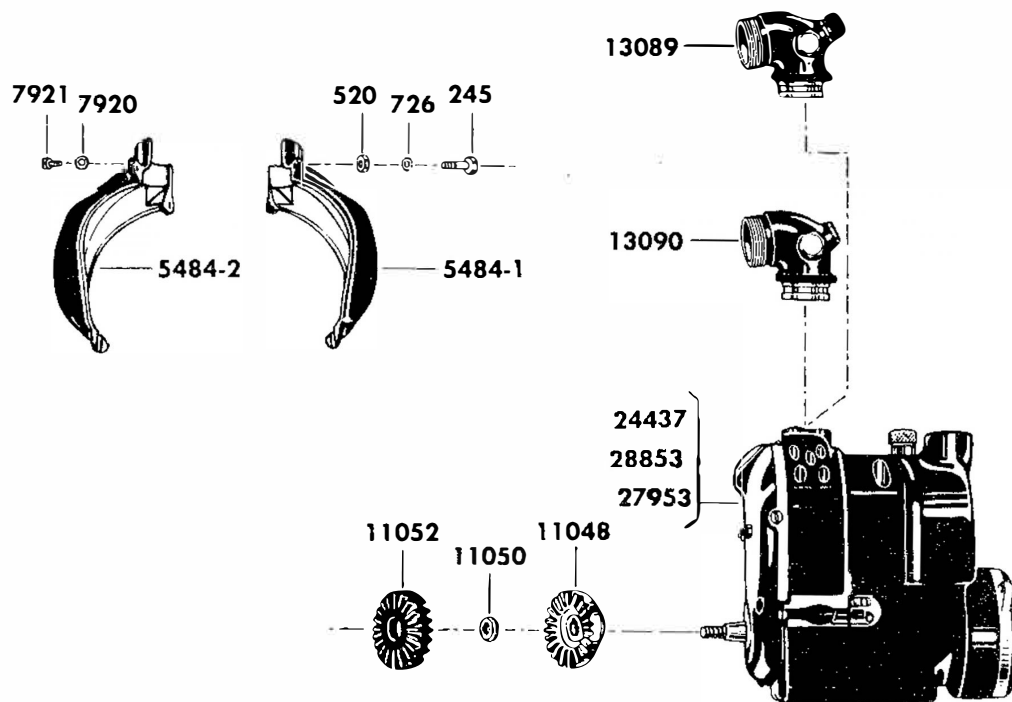

Figure 14. Magneto and Attaching Parts

CARBURETOR AND ATTACHING PARTS

Figure Number	Part Number	1	2	3	4	5	6	7	Nomenclature	Units Per Assy
15	16487								Adapter & Studs Assembly — NA-R9 Carburetor (for all engines except B4)	1
	74947								Elbow & Studs Assembly — Carburetor adapter NA-R9B-19 carburetor (for B4 only)	1
	*10413								Adapter — Carburetor (for all engines except B4)	1
	*74927								Elbow — Carburetor adapter (for B4 only)	1
15	†12091+4								Stud — Plain .375-16-24 thd x 1.781 in. long (carburetor) .004 in. oversize	4
	12091+8								Stud same as 12091 only .008 in. oversize	
	12091+12								Stud same as 12091 only .012 in. oversize	
15	172								Washer — Plain $\frac{2}{16}$ ID x $\frac{9}{16}$ OD x $\frac{1}{16}$ in. thick (carburetor adapter nuts: for engines using NA-R9B carburetors; use (4) units for engines using NA-R9C2 carburetors)	6
15	33415								Nut — Fibre insert $\frac{5}{16}$ -24 thd x $\frac{23}{64}$ in. thick (carburetor adapter to rear crankcase)	4
15	AN 121553								Nut — Castle .3125-24 thd x .328 in. thick (carburetor adapter to rear crankcase; supersedes No. 511)	2
15	6								Cotterpin — .072-.076 dia x .750 in. long (for use with Part No. 511 carburetor adapter nuts)	2
	37091								Carburetor — NA-R9B-18	1
15	11598								Carburetor — NA-R9B-19	1
	91316								Carburetor & Studs Assembly — NA-R9C2-4	1
	91317								Carburetor & Studs Assembly — NA-R9C2-5	1
	91318								Carburetor & Studs Assembly — NA-R9C2-5	1
	35815								Carburetor & Studs Assembly — NA-R9C2-6	1
	91291								Carburetor — NA-R9C2-4	1

CARBURETOR AND ATTACHING PARTS

Figure Number	Part Number	1	2	3	4	5	6	7	Nomenclature	Units Per Assy
	91292								Carburetor — NA-R9C2-5	1
	91293								Carburetor — NA-R9C2-5	1
	34094								Carburetor — NA-R9C2-6	1
	†35807+4								Stud — Plain .3125-18-24 thd x 1.390 in. long (carburetor bracket top) .004 in. oversize	1
	35807+8								Stud same as 35807 only .008 in. oversize	
	35807+12								Stud same as 35807 only .012 in. oversize	
	†35809+4								Stud — Plain .3125-18-24 thd x 2.328 in. long (carburetor bracket) .004 in. oversize	1
	35809+8								Stud same as 35809 only .008 in. oversize	
	35809+12								Stud same as 35809 only .012 in. oversize	
	†35810+4								Stud — Plain .3125-18-24 thd x 1.453 in. long (carburetor bracket) .004 in. oversize	1
	35810+8								Stud same as 35810 only .008 in. oversize	
	35810+12								Stud same as 35810 only .012 in. oversize	
	180799								Decalcomania — Rubber cure date	1
	57686								Cover — Induction port dehydrator	1
	43340								Cover — Carburetor adapter shipping	1
15	173								Washer — Plain $\frac{25}{64}$ ID x $\frac{11}{16}$ OD x $\frac{1}{16}$ in. thick (carburetor nuts)	4
15	26432								Nut — Fibre insert $\frac{3}{8}$ -24 thd x $\frac{29}{64}$ in. thick (carburetor to adapter)	4
15	12046								Gasket — Carburetor air screen (for engines using NA-R9B carburetors)	2
15	39910								Gasket — Carburetor air screen (for engines using NA-R9C2 carburetors)	2
15	6906								Screen — Carburetor air (for engines using NA-R9B carburetors)	1
15	39697								Screen — Carburetor air (for engines using NA-R9C2 carburetors)	1
15	6277								Screw — $\frac{1}{2}$ Hexagon head drilled x $\frac{5}{16}$ -18 thd x $\frac{3}{8}$ in. long (carburetor air screen; for engines using NA-R9C2 carburetors & for engines using NA-R9B carburetors with $\frac{5}{16}$ -18 thd inserts in the intake flange)	4
15	172								Washer — Plain $\frac{21}{64}$ ID x $\frac{9}{16}$ OD x $\frac{1}{16}$ in. thick (carburetor air screen nuts; for engines using NA-R9B carburetors with $\frac{5}{16}$ -24 thd studs in the intake flange)	4
15	33415								Nut — Fibre insert $\frac{5}{16}$ -24 thd x $\frac{23}{64}$ in. thick (carburetor air screen; for engines using NA-R9B carburetors with $\frac{5}{16}$ -24 thd studs in the intake flange)	4
	128648								Spacer — Carburetor shipping	2
	128651								Board — Carburetor shipping	1
15	48601								Spacer — .344 ID x .688 OD x .406 in. thick (for use when installing NA-R9B carburetors on rear sections studded for NA-R9C2 carburetors)	2
15	33267								Bracket — (For NA-R9C2 carburetors)	1
15	33268								Bracket — (For NA-R9C2 carburetors)	1
15	172								Washer — Plain $\frac{21}{64}$ ID x $\frac{9}{16}$ OD x $\frac{1}{16}$ in. thick (carburetor bracket nuts; for NA-R9C2 carburetors)	4
15	33415								Nut — Fibre insert $\frac{5}{16}$ -24 thd x $\frac{23}{64}$ in. thick (carburetor brackets; for NA-R9C2 carburetors)	4
	7766								Tag — Oil slushed carburetor warning	1
	49710								Tag — Fuel warning	1
15	14828								Elbow — .250 dia Tubing union 90° x .125-27 in. ANPT (carburetor to primer distributor tubing connection; for B3 & B5 only)	1
	27358								Tubing Assembly — Carburetor to primer distributor (for B3 & B5 only)	1
15	27357								Tubing — Carburetor to primer distributor (for B3 & B5 only)	1
15	14827								Nut — .562 Hexagon head x .4375-20 thd x .500 in. thick (primer distributor tubing coupling; for B3 & B5 only)	2
15	49847								Cone — .250 in. dia Tubing union (primer distributor tubing; for B3 & B5 only)	2

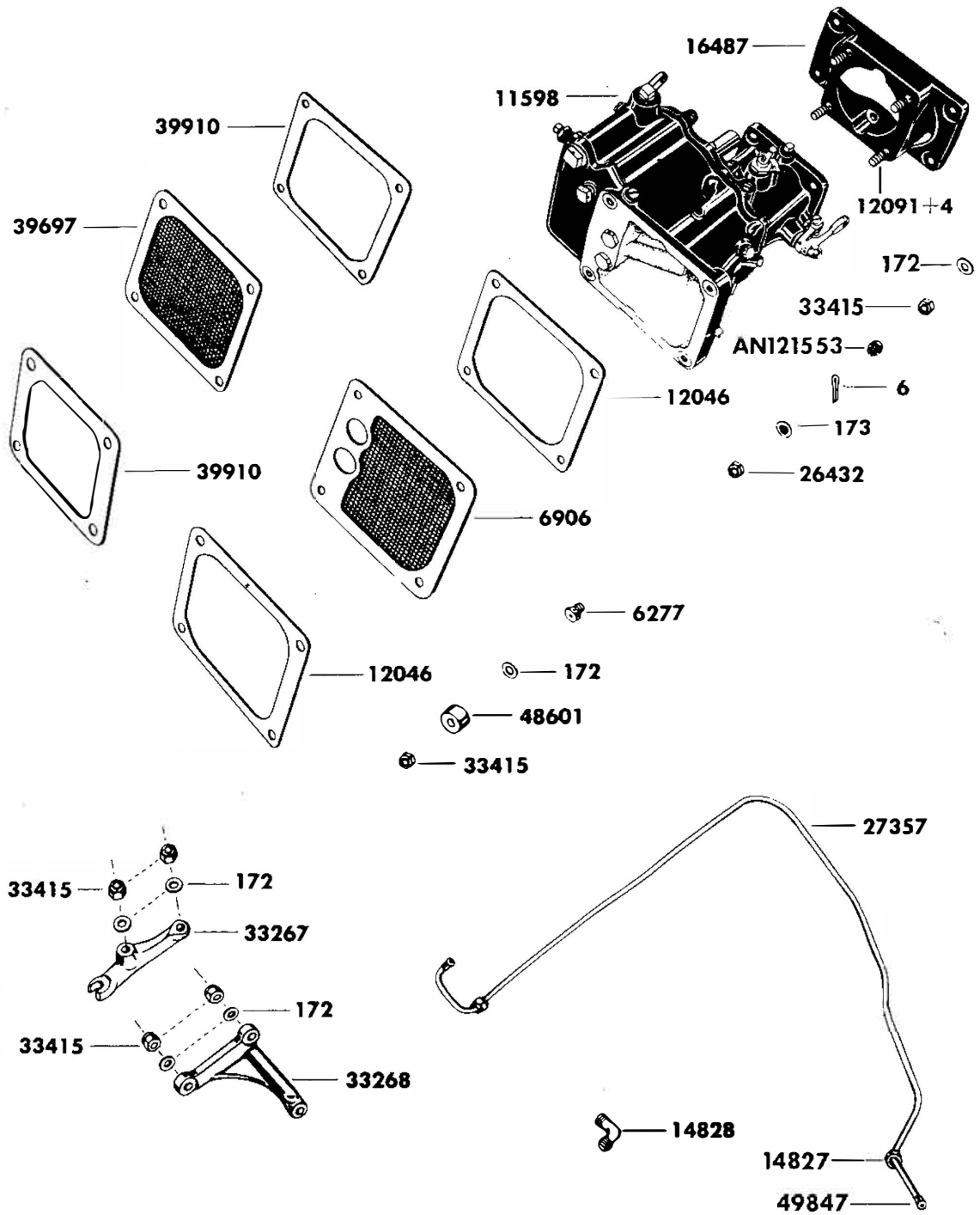

Figure 15. Carburetor and Attaching Parts

**P&W
R985
WASP JR.
SERIES**

***AN-1, -3, -4, -6, -6B,
-10, -12, -12B, -14B, B3,
B4, AND B5 ENGINES***

**ILLUSTRATED
PARTS
CATALOG**

SECTION III
ALPHABETICAL PARTS LIST

Part Number	Nomenclature	Figure Number	Page Number	Total Units Assy.
A				
35517	Adapter Assembly — Vacuum pump splined drive	10	47	1
*10413	Adapter — Carburetor (for all engines except B4)		57	1
5204	Adapter — Gun synchronizer housing (for AN engines only)	10	46	1
16487	Adapter & Studs Assembly — NA-R9 Carburetor (for all engines except B4) ..	15	57	1
*35138	Adapter — Vacuum pump splined drive		47	1
A-25695	Assemble Contact — Spring & retaining nut (Titeflex; for service procurement)		56	18
B				
13755	Baffle — Collector drive oil (for all engines except B4)	8	34	1
11473	Ball — End — Pushrod	5	21	36
*2488	Ball — Valve Clearance adjusting screw		18	9
*2488	Ball — Valve Clearance adjusting screw		18	9
9423	Band — Blower spring drive friction	4	14	1
*47517	Barrel — Cylinder		17	9
76366	Bearing — Flanged .490 ID x .626 OD x .592 in. long (tachometer coupling; for AN engines only)		45	1
80483	Bearing — Flanged 1.555 ID x 1.798 OD x .946 in. long (impeller shaft rear; for B4 only)		31	1
80485	Bearing — Impeller shaft front (for B4 only)		31	1
80486	Bearing & Liner Assembly — Impeller shaft (for B4 only)		31	1
†32983	Bearing — Masterod (for all engines except B4)	4	15	1
†128495	Bearing — Masterod (<i>supersedes</i> No. 32983 for B4)		16	1
288943	Bearing Option — Collector intermediate (procurement number consists of: Part No. 12768, 288910 & 359236 bearing)	8	33	1
		8	34	1
357281	Bearing Option — Collector intermediate (<i>supersedes</i> No. 12769; procurement number consists of: Part No. 20416 & 357276 bearing)	8	33	1
288947	Bearing Option — Crankshaft rear main (procurement number consists of: Part No. 32835, 288914 & 359238 bearing)	4	14	1
325683	Bearing Option — Front main (procurement number consists of: Part No. 71139 & 325682 bearing)	4	15	1
288936	Bearing Option — Generator pinion (procurement number consists of: Part No. 122, 288904 & 359233 bearing)	9	44	2
288933	Bearing Option — Gun control shaft (procurement number consists of: Part No. 109, 288901 & 359232 bearing)	10	46	2
288933	Bearing Option — Gun synchronizer (procurement number consists of: Part No. 109, 288901 & 359232 bearing)	11	48	2
288943	Bearing Option — Impeller shaft (for all engines except B4; procurement number consists of: Part No. 12768, 288910 & 359236 bearing)	8	34	2
288934	Bearing Option — Propeller thrust (procurement number consists of: Part No. 117 & 288902 bearing)	2	8	1
288938	Bearing Option — Rocker arm (procurement number consists of: Part No. 9016, 288906 & 359234 bearing)	5	19	18

Section III
Alphabetical Parts List

Parts Catalog

Part Number	Nomenclature	Figure Number	Page Number	Total Units Assy.
288932	Bearing Option— Starter gear (procurement number consists of: Part No. 104, 288900 & 359231 bearing)	8	44	1
71139	Bearing— Roller 2.9524-2.9528 ID x 5.1176-5.1181 OD x .9813-.9843 in. long (front main; <i>supersedes No. 10781</i>)	4	14	1
128651	Board — Carburetor shipping		58	1
35230	Body — Breather connection (for all engines except B4)	8	35	1
77761	Body — Breather connection (for B4 only)		6	1
*39979	Body Deflector — Inter ear		22	9
*38360	Body — Oil pressure pump		41	1
17574	Body — Oil pressure relief valve	10	43	1
*38362	Body — Oil pump suction		41	1
*38361	Body — Oil suction pump		41	1
AN 101010	Bolt — .367-.376 Hexagon head x .190-32 NF-3A thd x .625 in. long (thermo-couple clip; <i>supersedes No. 41174</i>)	5	22	1
13700	Bolt — $\frac{7}{16}$ Hexagon head drilled x $\frac{1}{4}$ -28 thd x $1\frac{9}{32}$ in. long (connection breather exhaust; for B4 only)		6	1
23904	Bolt — $1\frac{1}{8}$ Hexagon head x $\frac{3}{4}$ -16 thd x $5\frac{19}{64}$ in. long (crankshaft)	4	12	1
38368	Bolt — $\frac{7}{16}$ Slotted hexagon head x $\frac{1}{4}$ -28 thd x $3\frac{15}{16}$ in. long (oil pump)	10	41	4
15950	Bolt — Blower spring drive to crankshaft attaching	4	15	1
2636	Bolt — Cam special (gun synchronizer gear)	11	48	1
5658	Bolt — Drilled $\frac{7}{16}$ Hexagon head x $\frac{1}{4}$ -28 thd x $1\frac{45}{64}$ in. long (oil feed bracket)	3	11	2
24884	Bolt — Latch — Inter cylinder deflector	6	22	14
24884	Bolt — Latch — Inter cylinder deflector	6	24	2
24884	Bolt — Latch — Inter cylinder deflector	6	24	2
24884	Bolt — Latch — Inter cylinder deflector	6	25	2
24884	Bolt — Latch — Inter cylinder deflector	6	26	4
24884	Bolt — Latch — Inter cylinder deflector	6	26	2
24884	Bolt — Latch — Inter cylinder deflector	6	26	2
24884	Bolt — Latch — Inter cylinder deflector	6	27	2
24884	Bolt — Latch — Inter cylinder deflector	6	27	2
245	Bolt — Plain .375 Hexagon head x No. 10-32 thd x .812 in. long (magneto shields attaching)	14	56	4
12398	Bolt — Plain .500 Hexagon head x .3125-24 thd x .953 in. long (oil inlet cover)		43	2
25049	Bolt — Plain .625 Hexagon head x .4375-14 thd x 3.938 in. long (engine mount)		35	8
463	Bolt — Shouldered $\frac{5}{8}$ Hexagon head x $\frac{7}{16}$ -20 thd x $5\frac{1}{8}$ in. long (main crankcase halves & lifting links; use (2) units for all engines except B4)	3	11	4
464	Bolt — Shouldered $\frac{5}{8}$ Hexagon head x $\frac{7}{16}$ -20 thd x $4\frac{31}{32}$ in. long (main crankcase halves; use (4) units for B4)	3	11	6
39997	Bolt & Wing Nut Assembly — Inter cylinder deflector (for all locations except cylinders No. 5-6; use No. AS 100029 wire)	6	28	8
36054	Brace Assembly — Ignition manifold to crankcase stud	13	56	4
39995	Brace Assembly — Inter ear deflector		22	9
74012	Brace — Inter cylinder deflector small		26	2
74012	Brace — Inter cylinder deflector small		22	7
74012	Brace — Inter cylinder deflector small		26	1
74012	Brace — Inter cylinder deflector small		26	1
74012	Brace — Inter cylinder deflector small		27	1
74012	Brace — Inter cylinder deflector small		27	1
74012	Brace — Inter cylinder deflector small		27	1
74013	Brace — Inter cylinder deflector large		22	7
74013	Brace — Inter cylinder deflector large		24	1
74013	Brace — Inter cylinder deflector large		24	1
74013	Brace — Inter cylinder deflector large		26	2
74013	Brace — Inter cylinder deflector large		25	1
74013	Brace — Inter cylinder deflector large		26	1
74013	Brace — Inter cylinder deflector large		26	1
74013	Brace — Inter cylinder deflector large		27	1
74013	Brace — Inter cylinder deflector large		27	1
74013	Brace — Inter cylinder deflector large		27	1
76284	Brace — Inter cylinder deflector center		25	1

Parts Catalog

Part Number	Nomenclature	Figure Number	Page Number	Total Units Assy.
77323	Brace — Inter cylinder deflector nose		25	1
123596	Bracket Assembly — Fuel pump drive gear (<i>supersedes No. 46235</i>)		47	1
71149	Bracket Assembly — Inter cylinder deflector left (for all engines except B4)		25	1
82517	Bracket Assembly — Inter cylinder deflector right (for all engines except B4)		24	1
18599	Bracket Assembly — Oil feed	3	11	1
18600	Bracket Assembly — Oil feed rear		11	1
10269	Bracket — Blower oil pressure pipe	3	11	1
1326	Bracket — Collector oil pressure pipe	8	34	1
33267	Bracket — (for NA-R9C2 carburetors)	15	58	1
33268	Bracket — (for NA-R9C2 carburetors)	15	58	1
46232	Bracket — Fuel pump drive gear	10	47	1
71145	Bracket — Inter cylinder deflector left		25	1
71147	Bracket — Inter cylinder deflector left		25	1
82515	Bracket — Inter cylinder deflector right		24	1
82516	Bracket — Inter cylinder deflector right		24	1
*18016	Bracket — Oil feed		11	1
81188	Bracket & Pipe Assembly — Oil feed rear		11	1
38436	Breather Assembly — Rear (for all engines except B4)		35	1
†3496	Bushing — 18 m/m-1.5 m/m ID x 1.0811-1.0851 OD — 16 Pitch left x 1/2 in. long (sparkplug)	5	17	18
109454	Bushing — .750 ID x 1.1895 OD x .965 in. long (front case; for B4 only)		5	1
†10682	Bushing — Flanged 3/8-18 ID x 3/4-14 OD x 7/8 in. long (pipe reducing)	10	36	1
†10682	Bushing — Flanged 3/8-18 ID x 3/4-14 OD x 7/8 in. long (pipe reducing swivel fitting; for all engines except B4)	10	39	2
†2943	Bushing — Flanged .6245 ID x .751 OD x .480 in. long (valve rocker shaft inside)	5	17	18
109453	Bushing — Flanged .625 ID x .752 OD x .870 in. long (oil transfer tube; for B4 only)		5	1
35139	Bushing — Flanged .865 ID x 1.053 OD x .859 in. long (vacuum pump splined drive)	10	47	1
†5670	Bushing — Flanged .995 ID x 1.189 OD x 1.961 in. long (cam reduction gear)	3	10	1
†20117	Bushing — Flanged 1.18 ID x 1 1/16-12 OD x 2 3/32 in. long (oil sump drain plugs; for all engines except B4)		28	2
†1171	Bushing — Gun control		36	2
†1172	Bushing — Magneto drive shaft short	8	33	2
†1174	Bushing — Magneto drive shaft long	9	40	2
326	Bushing — Plain 1.053 ID x 1.231 OD x 1.366 in. long (linkpin)	4	17	8
84251	Bushing — Plain 1.375 ID x 1.5348 OD x 1.750 in. long (pistonpin; <i>supersedes No. 337</i>)	4	15	1
84251	Bushing — Plain 1.375 ID x 1.5348 OD x 1.750 in. long (pistonpin; <i>supersedes No. 337</i>)	4	17	8
†1191	Bushing — Starter shaft	9	39	1
†2108	Bushing — Valve rocker shaft outside	5	17	18
12677	Button — Blower spring drive	4	15	14

C

165376	Cable Assembly — Radio shielded ignition front (for use with Scintilla magnetos SB9RN-4; <i>supersedes No. 90461 & 90480</i>)	13	50	1
165375	Cable Assembly — Radio shielded ignition rear (for use with Scintilla magnetos SB9RN-4; <i>supersedes No. 90456 & 90481</i>)	13	54	1
39649	Cable Assembly — Radio shielded ignition rear (for use with Scintilla magnetos & has non-detachable sparkplug elbows; for B3 only)		54	1
39650	Cable Assembly — Radio shielded ignition front (for use with Scintilla magnetos & has non-detachable sparkplug elbows; for B3 only)		50	1
47131	Cable Assembly — Radio shielded ignition front (for use with Bosch magnetos; has cadmium plated sparkplug elbows & full length ceramic sparkplug connectors)		50	1
47132	Cable Assembly — Radio shielded ignition rear (for use with Bosch magnetos; has cadmium plated sparkplug elbows & full length ceramic sparkplug connectors)		54	1

Section III
Alphabetical Parts List

Parts Catalog

Part Number	Nomenclature	Figure Number	Page Number	Total Units Assy.
84462	Cable Assembly — Radio shielded ignition front (for use with Bosch magnetos; had cadmium plated sparkplug elbows & inland neoprene & ceramic sparkplug connectors)		50	1
84463	Cable Assembly — Radio shielded ignition rear (for use with Bosch magnetos; had cadmium plated sparkplug elbows & inland neoprene & ceramic sparkplug connectors)		54	1
113811	Cable Assembly — Radio shielded ignition front (for use with Scintilla magnetos SB9RN; has plain brass sparkplug elbows & full length ceramic sparkplug connectors)		50	1
113812	Cable Assembly — Radio shielded ignition rear (for use with Scintilla magnetos SB9RN; has plain brass sparkplug elbows & full length ceramic sparkplug connectors)		54	1
96121	Cable — Special purpose electrical ignition 5 M/M (detail of assembly No. 90461; use as required)		50	
96121	Cable — Special purpose electrical ignition 5 M/M (detail of assembly No. 90456; use as required)		54	
123790	Cable — Special purpose electrical ignition 7 M/M (detail of all assemblies except No. 90461; <i>supersedes</i> No. 37141; use as required)	13	50	
123790	Cable — Special purpose electrical ignition 7 M/M (detail of all assemblies except No. 90456; <i>supersedes</i> No. 37141; use as required)	13	54	
97927	Cage Assembly — Collector drive (for B4 only)		34	1
47913	Cage Assembly — Main collector drive (for all engines except B4)	8	33	1
5025	Cage — Collector intermediate shaft ball bearing	8	31	1
*9036	Cage — Collector shaft ball bearing (for all engines except B1)	8	33	1
*5021	Cage — Impeller intermediate gear front bearing (for all engines except B4)		34	1
*80494	Cage — Impeller shaft bearing (for B4 only)		34	1
*7590	Cam		11	1
2631	Cam — 35° Angle (magnetic gun control)	11	48	1
9903	Cam Assembly	3	11	1
54363	Cap — .5625-27-NS-1 in. (sparkplug connector protecting; detail of assembly No. 39650)		52	9
54363	Cap — .5625-27-NS-1 in. (sparkplug connector protecting; detail of assembly No. 39649)		55	9
183748	Cap — .625-18 NS thd (oil pressure relief valve; <i>use</i> No. A5 100029 <i>uire</i> ; <i>supersedes</i> No. 8699)	10	43	1
54364	Cap — .625-24-NS-1 in. (sparkplug connector protecting; detail of all assemblies except No. 39650)	13	52	9
54364	Cap — .625-24-NS-1 in. (sparkplug connector protecting; detail of all assemblies except No. 39649)	13	55	9
14322	Cap — 11/16-24 x 2 1/2 in. OD (high tension lead coupling)		56	1
36553	Cap — No. 30 (propeller shaft thread; for AN-14B, B3 & B5 only)	4	12	1
91745	Cap — No. 30 (propeller shaft thread; for all engines except AN-14B, B3 & B5)	4	12	1
2032	Cap — Cam plunger	11	48	1
2211	Cap — Tachometer coupling (use (1) unit for B4)	9	45	2
37091	Carburetor — NA-R9B-18		57	1
11598	Carburetor — NA-R9B-19	15	57	1
91291	Carburetor — NA-R9C2-4		57	1
91292	Carburetor — NA-R9C2-5		58	1
91293	Carburetor — NA-R9C2-5		58	1
34094	Carburetor — NA-R9C2-6		58	1
35815	Carburetor & Studs Assembly — NA-R9C2-6		57	1
91316	Carburetor & Studs Assembly — NA-R9C2-4		57	1
91317	Carburetor & Studs Assembly — NA-R9C2-5		57	1
91318	Carburetor & Studs Assembly — NA-R9C2-5		57	1
48564	Case Assembly Complete — Rear (for AN engines using NA-R9B carburetors)		36	1
48565	Case Assembly Complete — Rear (for AN engines using NA-R9C2 carburetors)		36	1
114377	Case Assembly Complete — Rear (for B3 & B5 engines using NA-R9B carburetors)		36	1
114378	Case Assembly Complete — Rear (for B3 & B5 engines using NA-R9C2 carburetors)		36	1

Part Number	Nomenclature	Figure Number	Page Number	Total Units Assy.
123724	Case Assembly Complete — Rear (replaces No. 123547; for B4 with oil seals)		36	1
*39106	Case Casting Assembly — Rear (for all engines except B4)		36	1
*80495	Case Casting Assembly — Rear (for use with Part No. 123547 rear case & studs assembly; for B4 only)		36	1
*121216	Case Casting Assembly — Rear (for use with Part No. 123724 case & studs assembly; for B4 only)		36	1
*39485	Case — Front section (for all engines except B4)		5	1
*109720	Case — Front section (for B4 only)		5	1
*121211	Case Machining Assembly — Collector (replaces No. 86883; for use with Part No. 126310 collector case)		30	1
*57999	Case Machining Assembly — Rear (for all engines except B4)		36	1
*121217	Case Machining Assembly — Rear (replaces No. 80496; for use with Part No. 123724 rear case & studs assembly; for B4 only)		36	1
39487	Case & Studs Assembly — Front (for all engines except B4)	2	5	1
109722	Case & Studs Assembly — Front (for B4 only)		5	1
126299	Case & Studs Assembly — Rear (for AN engines using NA-R9B carburetors; <i>supersedes No. 47554</i>)	9, 10	36	1
126301	Case & Studs Assembly — Rear (for B3 & B5 engines using NA-R9B carburetors; <i>supersedes No. 45948 & 114380</i>)	9, 10	36	1
126302	Case & Studs Assembly — Rear (for B3 & B5 engines using NA-R9C2 carburetors; <i>supersedes No. 45949 & 114381</i>)	9, 10	36	1
126304	Case & Studs Assembly — Rear (replaces No. 126305; for use with Part No. 123724 rear case & studs assembly; for B4 only)		36	1
126307	Case & Stud Assembly — Collector (<i>supersedes No. 40987</i> for B3 & B5)	8	30	1
126308	Case & Studs Assembly — Collector (<i>supersedes No. 47972</i> for AN engines)	8	30	1
126310	Case & Studs Assembly — Collector (replaces No. 126309; for B4 with oil seals)		30	1
151882	Case & Studs Assembly — Rear (for AN engines using NA-R9C2 carburetors; <i>supersedes No. 47616</i>)	9, 10	36	1
10486	Circllet — Intake valve	5	19	9
35012	Clamp — No. 5 Sparkplug lead to suction pipe		56	1
34079	Clamp Assembly — 1.125 in. ID Hose (inter cylinder oil drain hose; use (8) units for all engines except B4)	5	21	16
34079	Clamp Assembly — 1.125 in. ID Hose (oil drain hose; for all engines except B4)	7	30	4
34079	Clamp Assembly — 1.125 in. ID Hose (cylinder head oil drain; for B4 only)		39	3
35013	Clamp Assembly — No. 5 Sparkplug lead to suction pipe (detail of assembly No. 39649)		56	1
231627	Clamp Assembly Complete — Magneto conduit to rear ignition manifold (<i>supersedes No. 35091</i>)	13	52	1
231627	Clamp Assembly Complete — Magneto conduit to rear ignition manifold (<i>supersedes No. 35091</i>)	13	52	1
40000	Clamp Assembly — Inter cylinder deflector (for all locations except cylinders No. 5-6)	6	28	8
231628	Clamp Assembly — Magneto conduit (<i>supersedes No. 37123</i>)		52	1
231628	Clamp Assembly — Magneto conduit (<i>supersedes No. 37123</i>)		52	1
395296	Clamp — Assembly of, inter ear oil drain pipe hose (<i>supersedes No. 38093</i> ; use on cylinders No. 4, 5, 6 & 7; for all engines except B4)	5	20	18
48776	Clamp Assembly — Primer tubing to intake pipes	12	50	10
38355	Clamp — Breather connection (for all engines except B4)		35	1
395297	Clamp — Hose (inter ear oil drain pipe)	5	20	18
39999	Clamp — Inter cylinder deflector		28	8
10395	Clip — No. 5 Spark plug lead to suction pipe (detail of all assemblies except No. 39649)	13	56	1
23930	Clip — Cylinders No. 3 & 8 (primer tubing to ignition manifold)	12	50	2
73996	Clip — Inter ear deflector tube		22	9
80328	Clip — Inter ear deflector tube		22	9
101249	Clip — Thermocouple cylinder head	5	22	1
5023	Closure — Collector shaft ball bearing (for all engines except B4)		34	1
73984	Collar — Inter cylinder deflector		26	1

Section III
 Alphabetical Parts List

Parts Catalog

Part Number	Nomenclature	Figure Number	Page Number	Total Units Assy.
74015	Collar—Inter cylinder deflector		24	1
59482	Collar—Spark plug elbow waterproof (detail of assembly No. 84462)		52	9
59482	Collar—Spark plug elbow waterproof (detail of assembly No. 84463)		55	9
33694	Conduit Assembly—Front ignition manifold to magneto (detail of all assemblies except No. 113811, 90480, 90461 & 165376)		52	1
90437	Conduit Assembly—Front ignition manifold to magneto (detail of assembly No. 113811, 90480, 90461 & 165376)	13	52	1
33241	Conduit Assembly—Manifold to spark plug (cylinder No. 5; detail of assembly No. 39649)		55	1
34585	Conduit Assembly—Manifold to spark plug (cylinder No. 6; detail of assembly No. 39649)		55	1
34587	Conduit Assembly—Manifold to spark plug (detail of assembly No. 39650)		52	9
34588	Conduit Assembly—Manifold to spark plug (cylinders No. 1, 2, 3, 4, 7, 8 & 9; detail of assembly No. 39649)		54	7
92367	Conduit Assembly—Manifold to spark plug (detail of all assemblies except No. 39650)	13	52	9
92372	Conduit Assembly—Manifold to spark plug (cylinders No. 1, 2, 3, 4, 7, 8 & 9; detail of all assemblies except No. 39649)	13	54	7
92373	Conduit Assembly—Manifold to spark plug (cylinder No. 6; detail of all assemblies except No. 39649)	13	54	1
92374	Conduit Assembly—Manifold to spark plug (cylinder No. 5; detail of all assemblies except No. 39649)	13	55	1
33695	Conduit Assembly—Rear ignition manifold to magneto (detail of all assemblies except No. 113812, 90481, 90456 & 165375)		55	1
90440	Conduit Assembly—Rear ignition manifold to magneto (detail of assembly No. 113812, 90481, 90456 & 165375)	13	55	1
92370	Conduit—Flexible .320 ID x .500 in. OD (manifold to spark plug)	13	52	63 in.
92370	Conduit—Flexible .320 ID x .500 in. OD (manifold to spark plug)	13	54	49 in.
92370	Conduit—Flexible .320 ID x .500 in. OD (manifold to spark plug)	13	54	9 in.
92370	Conduit—Flexible .320 ID x .500 in. OD (manifold to spark plug)	13	55	13 in.
29894	Conduit—Flexible $2\frac{1}{16}$ ID x $\frac{7}{16}$ in. OD (manifold to spark plug)		52	54 in.
29894	Conduit—Flexible $2\frac{1}{16}$ ID x $\frac{7}{16}$ in. OD (manifold to spark plug)		54	42 in.
29894	Conduit—Flexible $2\frac{1}{16}$ ID x $\frac{7}{16}$ in. OD (manifold to spark plug)		55	8 in.
29894	Conduit—Flexible $2\frac{1}{16}$ ID x $\frac{7}{16}$ in. OD (manifold to spark plug)		55	12 in.
*362612	Conduit—Front ignition manifold to magneto (<i>supersedes</i> No. 33692)		52	22 in.
*362612	Conduit—Front ignition manifold to magneto (<i>supersedes</i> No. 33692)		52	22 in.
49847	Cone—.250 in. dia Tubing union (primer distributor tubing; for B4 & B5 only)	15	58	2
45936	Connections Assembly—Primer		30	1
38354	Connection—Breather (for all engines except B4)		35	1
38353	Connection—Breather exhaust (for B4 only)		6	1
38353	Connection—Breather exhaust (for all engines except B4)	8	35	1
†9264	Connector—Push rod cover	5	19	18
82307	Connector—Sparkplug full length ceramic (detail of assembly No. 113811, 90480, 47131 & 165376)	13	52	9
82307	Connector—Sparkplug full length ceramic (detail of assembly No. 113812, 90481, 47132 & 165375)	13	55	9
29783	Connector—Sparkplug yellow bakelite (detail of assembly No. 39650)		52	9
29783	Connector—Sparkplug yellow bakelite (detail of assembly No. 39649)		55	9
304914	Contact Option—Sparkplug neoprene & ceramic (detail of assemblies No. 90461 or 84462; procurement number consists of: Part No. 59477 & 304911 contact)		52	9
304914	Contact Option—Sparkplug neoprene & ceramic (detail of assemblies No. 90456 or 84463; procurement number consists of: Part No. 59477 & 304911 contact)		55	9
50681	Cork—Generator drive pinion (for all engines except B4; <i>supersedes</i> No. 7435)	9	45	1
13621	Cork—Valve rocker shaft	5	19	18
10	Cotterpin—.058-.061 dia x .500 in. long (generator outboard bearing nut; for use with Part No. 135054 housing assembly; for all engines except B4)	9	45	1
3	Cotterpin—.072-.076 dia x 1.500 in. long (magneto drive shaft screws)	10	47	2

Parts Catalog

Alphabetical Parts List

Part Number	Nomenclature	Figure Number	Page Number	Total Units Assy.
2	Cotterpin — .072-.076 dia x 1.000 in. long (impeller shaft nut; for B4 only)		34	1
6	Cotterpin — .072-.076 dia x .750 in. long (for use with Part No. 511 carburetor adapter nuts)	15	57	2
7916	Cotterpin — .072-.076 dia x .500 in. long (oil feed bracket bolt nuts)		11	2
7916	Cotterpin — .072-.076 dia x .500 in. long (gun synchronizer; <i>supersedes</i> No. 11754)			
10185	Cotterpin — .072-.076 dia x .750 in. long (gun drive)	11	48	1
11357	Cotterpin — .086-.090 dia x 1.250 in. long (collector intermediate gear nut)	10	46	2
AS 123791	Cotterpin — .086-.090 dia x .750 in. long (starter shaft nut; P&W Part No. 11359)	8	33	1
20546	Cotterpin — .086-.090 dia x .875 in. long (locks crankshaft bolt; <i>supersedes</i> No. 8)		44	1
20546	Cotterpin — .086-.090 dia x .875 in. long (valve rocker shaft nut)		14	1
AS 123778	Cotterpin — .086-.090 dia x .500 in. long (cam reduction gear nut; <i>supersedes</i> No. 7916 or 73127)	5	20	18
20545	Cotterpin — .100-.105 dia x .750 in. long (blower spring drive bolt nut; <i>supersedes</i> No. 11359)	3	11	1
20545	Cotterpin — .100-.105 dia x .750 in. long (valve rocker shaft nut)	4	15	1
83323	Cotterpin — .100-.105 dia x .625 in. long (main crankcase bolt nut)	5	20	18
*34466	Counterweight — Front inner (<i>supersedes</i> No. 39916)		11	9
*34467	Counterweight — Front outer (<i>supersedes</i> No. 39917)		12	1
*39915	Counterweight — Rear		12	1
76467	Coupling Assembly — Tachometer inner (for AN engines only)	9	45	2
14321	Coupling — High tension lead		56	1
164316	Coupling — Magneto drive (for use with magnetos having lip type oil seal)	10	47	2
76365	Coupling — Tachometer (for AN engines only)		45	1
13028	Coupling — Tachometer left hand (for B3, B4 & B5 only)		45	1
14537	Coupling — Tachometer rear half (for AN engines only)	9	45	2
11590	Coupling — Tachometer right hand (for B3 & B5 only)		45	1
35961	Cover — .375 in. thick (accessory pad: fuel pump drive; <i>supersedes</i> No. 77907)	10	48	1
12874	Cover — Accessory pad (<i>supersedes</i> No. 70964)	9	44	1
8712	Cover Assembly — Collector bearing (for all engines except B4)	8	33	1
80493	Cover Assembly — Impeller shaft bearing (for B4 only)		33	1
1482	Cover Assembly — Magneto drive (for use with magnetos not having lip type oil seal)		47	2
282992	Cover Assembly — Pushrod (<i>supersedes</i> No. 39292)	5	21	18
43340	Cover — Carburetor adapter shipping		58	1
6262	Cover — Carburetor ell (for B3, B4 & B5 only)	10	40	1
25821	Cover — Carburetor ell (for AN engines only)		40	1
*8710	Cover — Collector bearing (for all engines except B4)		33	1
*80492	Cover — Collector bearing (for B4 only)		33	1
3773	Cover — Exhaust port shipping (for all engines except B5)		35	9
40383	Cover — Exhaust port shipping (for B5 only)		35	1
39528	Cover — Exhaust valve rockerbox (cylinders No. 4, 5, 7 & 8; for all engines except B4)	5	21	9
40049	Cover — Exhaust valve rockerbox (cylinder No. 6; for all engines except B4)	5	21	1
1154	Cover — Generator drive (<i>supersedes</i> No. 79514)	9	45	1
12574	Cover — Gun drive	10	46	2
39133	Cover — Gun synchronizer	11	48	1
57686	Cover — Induction port dehydrator		58	1
39314	Cover — Intake & exhaust rockerbox (cylinders No. 1, 2 & 9; for all engines except B4; use (1) unit on cylinder No. 3 exhaust rockerbox & (1) unit on cylinder No. 8 intake rockerbox)	5	21	8
39527	Cover — Intake rockerbox (use on cylinders No. 3, 4, 6 & 7; for all engines except B4)	5	21	9
40050	Cover — Intake valve rocker (cylinder No. 5; for all engines except B4)	5	21	1
2383	Cover — Magneto drive (for use with magnetos not having lip type oil seal)		47	2
33858	Cover — Oil connection shipping		43	2
19209	Cover — Oil control valve (for AN engines only)	2	6	1
10524	Cover — Oil screen	9	43	1

Section III
Alphabetical Parts List

Parts Catalog

Part Number	Nomenclature	Figure Number	Page Number	Total Units Assy.
80983	Cover — Propeller regulator valve (for B4 only)		6	1
*39287	Cover — Pushrod		21	18
74929	Cover — Sump pad front (for B4 only)		30	1
74932	Cover — Sump pad rear (<i>supersedes No. 44932</i> ; for B4 only)		30	1
2147	Cover — Tachometer drive right hand (for B4 only)		45	1
37965	Cover — Thrust bearing	2	8	1
9632	Cover — Vacuum pump drive	10	47	1
16475	Crankcase Assembly — Main (for all engines except B4)	3	8	1
80806	Crankcase Assembly — Main (for B4 only)		8	1
*3508	Crankcase — Front main (for all engines except B4)		8	1
*80804	Crankcase — Front main (for B4 only)		8	1
*13715	Crankcase Machining Assembly — Main (for all engines except B4)		8	1
*80805	Crankcase Machining Assembly — Main (for B4 only)		8	1
*13645	Crankcase — Rear main (for all engines except B4)		10	1
*74943	Crankcase — Rear main (for B4 only)		10	1
261280	Crankshaft Balancing Assembly With Plugs — (for AN-14B, B3 & B5 with 1 ³ / ₁₆ -16N-3 in. crankshaft distributor valve thread; replaces No. 42087 crankshaft assembly with 1 ⁵ / ₁₆ -16N-3 in. crankshaft distributor valve thread; <i>supersedes No. 39892</i>)	4	12	1
261281	Crankshaft Balancing Assembly With Plugs — (for B4 only; <i>supersedes No. 80986 or 261296</i>)		12	1
*261278	Crankshaft — Front (for B4 only; <i>supersedes No. 46553</i>)		12	1
*261279	Crankshaft — Front (for AN-14B, B3 & B5 only; contained in Part No. 39892 crankshaft assembly; replaces No. 40350; <i>supersedes No. 39581</i>)		12	1
*39891	Crankshaft Machining & Balancing Assembly — (for AN-14B, B3 & B5 only; contained in Part No. 39892 crankshaft assembly; replaces No. 42086)		11	1
*47781	Crankshaft Machining & Balancing Assembly — (for B4 only)		11	1
*23834	Crankshaft — Rear		12	1
†11477	Cup — Pushrod ball rocker	5	19	9
†11477	Cup — Pushrod ball rocker	5	19	9
399353	Cylinder Assembly Complete — Cylinders No. 1, 2, 3, 4, 7, 8 & 9 (cylinders No. 4 & 7 for all engines; cylinders No. 1, 2, 3, 8 & 9 for B4 only; <i>supersedes No. 47555 or 126741</i>)		17	7
399354	Cylinder Assembly Complete — Cylinders No. 1, 2, 3, 8 & 9 (<i>supersedes No. 70951 or 126742</i> ; for all engines except B4)		17	5
399355	Cylinder Assembly Complete — Cylinders No. 5 & 6 (<i>supersedes No. 47556 or 126834</i>)		17	2
47518	Cylinder Machining & Studs Assembly — For all cylinders	5	17	9
D				
392441	Decalcomania — Rubber assembly date		21	1
392441	Decalcomania — Rubber assembly date		21	1
180799	Decalcomania — Rubber cure date		58	1
41461	Deflector Assembly Complete — (for all AN engines except AN-2 & -8; for B3 & B5 engines with magneto SB9RN-4)		22	1
41463	Deflector Assembly Complete — Inter cylinder (cylinders No. 5-6 sump; for all engines except B4)	6	24	1
48610	Deflector Assembly Complete — (for B3 & B5 engines with magneto SB9RN)		22	1
76369	Deflector Assembly Complete — (<i>supersedes No. 120670</i> for B4)		22	1
40593	Deflector Assembly — Inter cylinder (cylinders No. 8-9 for B4)		26	1
39982	Deflector Assembly — Inter cylinder (cylinders No. 1-2, 3-4, 4-5, 6-7, 7-8, 8-9 & 9-1 for B3 & B5 with magneto SB9RN — use (3) units for B3 & B5 engines with magneto SB9RN-4 & for all AN engines except AN-2 & -8 between cylinders No. 4-5, 6-7 & 9-1; use (4) units for B4 between cylinders No. 1-2, 3-4, 6-7 & 9-1)	6	22	7
39980	Deflector Assembly — Inter ear (for all cylinders)	6	22	9
39986	Deflector Assembly — Inter cylinder (cylinders No. 3-4 & 8-9; for all engines except AN-2, -8, B4, B3 & B5 with magneto SB9RN)	6	26	2
39988	Deflector Assembly — Inter cylinder (cylinders No. 2-3; for all engines except AN-2, -8 & B4)	6	24	1

Part Number	Nomenclature	Figure Number	Page Number	Total Units Assy.
39990	Deflector Assembly — Inter cylinder (cylinders No. 1-2; for all AN engines except AN-2 & -8; for B3 & B5 engines with magneto SB9RN-4)	6	27	1
39992	Deflector Assembly — Inter cylinder (cylinders No. 7-8; for all AN engines except AN-2 & -8; for B3 & B5 engines with magneto SB9RN-4)	6	26	1
40589	Deflector Assembly — Inter cylinder (cylinders No. 4-5; for B4 only)	27	27	1
71538	Deflector Assembly — Inter cylinder (for all engines except B4)	24	24	1
76328	Deflector Assembly — Inter cylinder (cylinders No. 5-6 sump; for B4 only)	25	25	1
76330	Deflector Assembly — Inter cylinder (cylinders No. 7-8; for B4 only)	27	27	1
80137	Deflector Assembly — Inter cylinder (cylinders No. 2-3; for B4 only)	24	24	1
*39981	Deflector — Inter cylinder	22	22	7
*39985	Deflector — Inter cylinder	26	26	2
*39987	Deflector — Inter cylinder	24	24	1
*39989	Deflector — Inter cylinder	27	27	1
*39991	Deflector — Inter cylinder	26	26	1
*40588	Deflector — Inter cylinder	27	27	1
*40592	Deflector — Inter cylinder	26	26	1
*41462	Deflector — Inter cylinder left	24	24	1
*76329	Deflector — Inter cylinder	25	25	1
*76331	Deflector — Inter cylinder	27	27	1
*80136	Deflector — Inter cylinder	24	24	1
*151744	Deflector — Inter cylinder right	24	24	1
156011	Disc — Name plate mount (<i>supersedes No. 22464</i> ; for all engines except B4)	7	28	1
11052	Disc — Rubber magneto coupling	14	56	2
100186	Distributor Assembly — Engine primer	50	50	1
27210	Distributor — Engine primer	12	50	1
69	Dowel — Shouldered .1405-.1415 dia x .188 in. long (gun synchronizer)	11	48	1
28834	Dowel — Straight .128 dia x .312 in. long (vacuum pump adapter locating)	36	36	1
63	Dowel — Straight .163 dia x .203 in. long (pistonpin bushing)	4	15	1
63	Dowel — Straight .163 dia x .203 in. long (pistonpin bushing)	4	17	8
70	Dowel — Straight .1875 dia x .688 in. long (gun synchronizer)	11	48	2
62	Dowel — Straight .250 dia x .625 in. long (thrust cover locating)	2	5	1
62	Dowel — Straight .250 dia x .625 in. long (oil pump locating)	36	36	1
†11051	Dowel — Straight .312 dia x .500 in. long (magneto locating)	9, 10	36	4
*1943	Drum — Cam	11	11	1

E

14828	Elbow — .250 dia Tubing union 90° x .125-27 in. ANPT (carburetor to primer distributor tubing connection; for B4 & B5 only)	15	58	1
20229	Elbow Assembly — 1/8 in. Tubing (primer fuel; cylinder end of primer tubing)	12	50	5
13090	Elbow Assembly — Left hand magneto conduit radio shielding (for use with Scintilla magnetos SB9RN)	14	56	1
13089	Elbow Assembly — Right hand magneto circuit radio shielding (for use with Scintilla magnetos SB9RN)	14	56	1
*74927	Elbow — Carburetor adapter (for B4 only)	57	57	1
14319	Elbow — Left hand magneto conduit	56	56	1
74963	Elbow — Rear oil scavenge pipe to case (for B4 only)	39	39	1
14319	Elbow — Right hand magneto conduit	56	56	1
29355	Elbow — Sparkplug	55	55	1
29355	Elbow — Sparkplug	55	55	1
29941	Elbow — Sparkplug	52	52	9
29941	Elbow — Sparkplug	54	54	7
185956	Elbow — Sparkplug (detail of assembly No. 113811, 90480, 90461, 165376, 84462 & 47131; <i>supersedes No. 92366 & 78643</i>)	13	52	9
185956	Elbow — Sparkplug (detail of assembly No. 113812, 90481, 90456, 165375, 84463 & 47132; <i>supersedes No. 92366 & 78643</i>)	13	55	9
74947	Elbow & Studs Assembly — Carburetor adapter NA-R9B-19 carburetor (for B4 only)	57	57	1
44718	Expander — Flyweight screw	4	12	2

Section III
Alphabetical Parts List

Parts Catalog

Part Number	Nomenclature	Figure Number	Page Number	Total Units Assy.
F				
49353	Fastener — Dzus type deflector		25	2
15893	Ferrule — .292 ID x .312 OD x .500 in. long (magneto end of 7 m/m ignition cable; detail of all assemblies except No. 90461)	13	54	9
15893	Ferrule — .292 ID x .312 OD x .500 in. long (magneto end of 7 m/m ignition cable; detail of all assemblies except No. 90456)	13	55	9
47266	Ferrule — .292 ID x .312 OD x .375 in. long (magneto end of 5 m/m ignition cable; detail of assembly No. 90461)		54	9
47266	Ferrule — .292 ID x .312 OD x .375 in. long (magneto end of 5 m/m ignition cable; detail of assembly No. 90456)		55	9
29407	Ferrule — .459 ID x .531 OD x $1\frac{3}{16}$ in. long (sparkplug conduit)		52	9
29407	Ferrule — .459 ID x .531 OD x $1\frac{3}{16}$ in. long (sparkplug conduit)		54	7
29407	Ferrule — .459 ID x .531 OD x $1\frac{3}{16}$ in. long (sparkplug conduit)		55	1
29407	Ferrule — .459 ID x .531 OD x $1\frac{3}{16}$ in. long (sparkplug conduit)		55	1
92369	Ferrule — .521-.527 ID x .630-.635 OD x .310 in. long (sparkplug conduit)	13	52	18
92369	Ferrule — .521-.527 ID x .630-.635 OD x .310 in. long (sparkplug conduit)	13	54	14
92369	Ferrule — .521-.527 ID x .630-.635 OD x .310 in. long (sparkplug conduit)	13	55	2
92369	Ferrule — .521-.527 ID x .630-.635 OD x .310 in. long (sparkplug conduit)	13	55	2
3900	Ferrule — .594 ID x .6890 OD x 1.000 in. long (crankcase oil hole)		10	1
†32735	Ferrule — .876 ID x .9380 OD x .844 in. long (pushrod cover)	5	21	36
*231623	Ferrule — Coupling nut		52	1
*231623	Ferrule — Magneto conduit (<i>supersedes No. 32370</i>)		52	2
46253	Fitting — .750 in. NPT (swivel; for all engines except B4)	10	39	2
13651	Fitting — Collector section oil pressure connection	8	30	1
13652	Fitting — Main crankcase oil pressure		10	1
48389	Fitting — Rocker oil drain (for all engines except B4)	7	30	1
3506	Flange — 2.156 in. OD Pipe (intake pipe)	8	35	9
10464	Flange — 2.156 in. OD Pipe (exhaust pipe; for all engines except B5)		35	9
75162	Flange — Blank .344 OD x .219 in. thick (collector case pipe opening; for B4 only)		35	1
11048	Flange — Magneto coupling	14	56	2
116576	Flange — Propeller governor oil pressure tube (For B3 & B5 only)	2	6	1
34464	Flyweight — Inner	4	12	1
34465	Flyweight — Inner	4	12	1
34462	Flyweight — Outer	4	12	1
34463	Flyweight — Outer	4	12	1
8288	Follower Assembly — Gun synchronizer	11	48	1
G				
16532	Gasket — .0016 in. thick (accessory pad vacuum pump drive cover)	10	47	1
744	Gasket — $\frac{5}{16}$ ID x .688 OD x .078 in. thick (tachometer coupling; use (1) unit for B4)	9	45	2
744	Gasket — $\frac{5}{16}$ ID x .688 OD x .078 in. thick (gun synchronizer)	11	48	1
1345	Gasket — .469 ID Pipe flanged x .031 in. thick (blower oil pressure pipe bracket)	3	11	1
1345	Gasket — .469 ID Pipe flanged x .031 in. thick (collector oil pressure pipe bracket)	8	34	1
743	Gasket — .516 ID x .688 OD x .078 in. thick (crankshaft front plug; for AN-14B, B3 & B5 only)	4	14	1
6558	Gasket — .531 ID Pipe flanged x .031 in. thick (rocker drain oil suction pipe; use (1) unit for B4 front case to rear pipe flange)	7	30	2
234	Gasket — .625 ID x .938 OD x .078 in. thick (carburetor ell cover plug; for AN engines only)		40	1
234	Gasket — .625 ID x .938 OD x .078 in. thick (oil inlet plug)	10	43	1
234	Gasket — .625 ID x .938 OD x .078 in. thick (oil thermometer hole plug)	10	43	1
234	Gasket — .625 ID x .938 OD x .078 in. thick (oil pressure relief valve cap)	10	43	1
8955	Gasket — .625 ID x .812 OD x .094 in. thick (valve rocker shaft; for use with Part No. 126741, 126742 or 126834)	5	20	18
827	Gasket — .688 ID Pipe flanged x .031 in. thick (main oil suction pipes; for all engines except B4)	7	30	2

Part Number	Nomenclature	Figure Number	Page Number	Total Units Assy.
827	Gasket — .688 ID Pipe flanged x .031 in. thick (rear oil scavenge; for B4 only)		39	1
6924	Gasket — .703 ID x .938 OD x .078 in. thick (oil pressure hole plug)		43	1
25893	Gasket — .718 ID x .968 OD x .0808 in. thick (spark plug)	5	22	18
40382	Gasket — 3/4 in. Pipe flanged (rocker oil drain fitting; for all engines except B4)	7	30	1
6191	Gasket — .812 ID Pipe flanged x .031 in. thick (collector case pipe flange; for B4 only)		35	1
6191	Gasket — .812 ID Pipe flanged x .031 in. thick (rear oil drain; for all engines except B4)	8	40	2
820	Gasket — .891 ID Pipe flanged x .016 in. thick (tachometer flange)	9	45	2
48139	Gasket — .90 ID x 1.500 OD x .015 in. thick (swivel fitting nut; for all engines except B4)	10	39	2
14126	Gasket — 1.000 ID x 1.188 OD x .078 in. thick (rear ignition manifold sections coupling nut)	13	54	1
89746	Gasket — 1.000 ID x 1.250 OD x .078 in. thick (sump oil strainer hole plug; supersedes No. 237 for all engines except B4)	7	30	1
237	Gasket — 1.008 ID x 1.250 OD x .094 in. thick (oil sump drain plug; for all engines except B4)		28	2
11042	Gasket — 1.016 ID Pipe flanged x .016 in. thick (oil inlet connection)		43	1
46256	Gasket — 1.05 ID x 1.6 OD x .015 in. thick (swivel fitting; for all engines except B4)		39	2
232	Gasket — 1.1325 ID x .125 Wall x .094 in. thick (oil pressure relief valve housing to rear case; supersedes No. 236)	10	43	1
35932	Gasket — 1.281 ID x 1.500 OD x .031 in. thick (body breather connection; for B4 only)		6	1
35932	Gasket — 1.281 ID x 1.500 OD x .031 in. thick (rear breather connection; for all engines except B4)	8	35	1
233	Gasket — 1.3825 ID x .125 Wall x .094 in. thick (front crankcase breather plug)	2	6	1
14128	Gasket — 1.422 ID x 1.562 OD x .031 in. thick (manifold to magneto conduit coupling nut)	13	54	1
14128	Gasket — 1.422 ID x 1.562 OD x .031 in. thick (manifold to magneto conduit coupling nut)	13	55	1
39577	Gasket — 1.469 ID x 1.672 OD x .063 in. thick (crankshaft plug inner; for AN-14B, B3 & B5 only)	4	14	1
235	Gasket — 2.375 ID x 2.750 OD x .094 in. thick (oil screen cover)	9	43	1
809	Gasket — 2 1/2 in. Square (magneto drive cover)	10	46	2
12046	Gasket — Carburetor air screen (for engines using NA-R9B carburetors)	15	58	2
39910	Gasket — Carburetor air screen (for engines using NA-R9C2 carburetors)	15	58	2
25820	Gasket — Carburetor ell cover (for AN engines only)		40	1
1778	Gasket — Collector bearing cover (for all engines except B4)	8	33	1
1187	Gasket — Collector to rear crankcase	9	35	1
39578	Gasket — Crankshaft plug outer (for AN-14B, B3 & B5 only)	4	14	1
72430	Gasket — Exhaust port shipping cover		35	9
34637	Gasket — Fuel pump & lubricator drive bracket		47	1
AS 100004	Gasket — Fuel pump drive cover (supersedes No. 21099 or 77908)	10	48	1
1189	Gasket — Generator drive cover (supersedes No. 84108)	9	45	1
242	Gasket — Inspection port	11	48	1
3503	Gasket — Intake & exhaust flange	8	35	18
9667	Gasket — Oil control valve cover (for AN engines only)	2	6	1
84106	Gasket — Oil inlet & outlet connections (for shipping only; use Part No. 11042 gasket for engine operation)		43	2
1325	Gasket — Oil sump to blower crankcase	7	30	1
3627	Gasket — Oil sump to nose housing	7	30	1
74945	Gasket — Pipe front case to rear (for B4 only)		8	1
9667	Gasket — Propeller governor oil pressure tube flange to front crankcase (for B3 & B5 only)	2	6	1
80984	Gasket — Propeller regulator valve cover (for B4 only)		6	1
17009	Gasket — Rear oil pump to rear case	10	41	1
90560	Gasket — Rockerbox cover (supersedes No. 39315)	5	21	18
7499	Gasket — Starter cover	9	44	1

Section III
Alphabetical Parts List

Pratt & Whitney Aircraft
Parts Catalog

Part Number	Nomenclature	Figure Number	Page Number	Total Units Assy.
9633	Gasket — Vacuum pump drive		47	1
6515	Gear — 10:1 (collector intermediate)	8	33	1
331098	Gear Assembly — Cam reduction (<i>supersedes No. 3965</i>)	3	11	1
46234	Gear Assembly — Fuel pump drive	10	48	1
16512	Gear Assembly — Gun synchronizer drive (for AN engines only)	10	46	1
2715	Gear Assembly — Gun control (use (1) unit for AN engines)	10	45	2
14357	Gear Assembly — Tachometer drive (for B3 & B5 only; use (1) unit for B4)	9	45	2
16047	Gear Assembly — Tachometer drive (for AN engines only)	9	45	2
37907	Gear Assembly — Vacuum pump drive		47	1
*2987	Gear — Cam countershaft (use with Part No. 3965)		11	1
†3033	Gear — Cam drive	3	11	1
*3447	Gear — Cam reduction small (use with Part No. 3965)		11	1
8797	Gear — Collector drive floating	8	34	1
9405	Gear — Crankshaft rear	4	14	1
1428	Gear — Drilled hole .561 dia x .9355 in. long (idler oil pressure pump)	10	41	1
8735	Gear — Drilled hole .561 dia x 1.2485 in. long (idler oil suction pump)	10	41	1
10110	Gear — Drilled hole .561 dia x .3755 in. long (idler oil suction rockerbox)	10	41	1
*46233	Gear — Fuel pump drive		48	1
1314	Gear — Fuel pump & gun control drive	10	46	2
2628	Gear — Gun drive right hand (for all engines except AN-1, -3, B3, B4 & B5)	10	46	1
1427	Gear — Keyed .561 dia x .9355 in. long (oil pressure pump)	10	43	1
8734	Gear — Keyed .561 dia x 1.2485 in. long (oil suction pump)	10	41	1
10502	Gear — Magneto drive		46	2
11049	Gear — Magneto drive coupling (for use with magnetos not having lip type oil seal)		47	2
38363	Gear — Oil pump drive	10	41	1
173007	Gear — Oil suction rockerbox (<i>supersedes No. 10129</i>)	10	43	1
81186	Gear & Ring Assembly — Cam drive		11	1
38367	Gear & Shaft Assembly — Oil pump idler		41	1
3278	Gear — Starter	8	44	1
*14356	Gear — Tachometer drive (for B3, B4 & B5 only)		45	1
*14604	Gear — Tachometer drive (for AN engines only)		45	1
35169	Gear — Vacuum pump splined drive	10	47	1
24116	Generator Assembly — 35° Gun synchronizer right hand		48	1
24117	Generator Assembly — 35° Gun synchronizer left hand		48	1
12012	Grommet — $\frac{5}{16}$ ID x $\frac{13}{16}$ OD x $\frac{5}{16}$ in. thick (inter ear deflector primer)		22	7
12012	Grommet — $\frac{5}{16}$ ID x $\frac{13}{16}$ OD x $\frac{5}{16}$ in. thick (inter ear deflector primer)		24	1
12012	Grommet — $\frac{5}{16}$ ID x $\frac{13}{16}$ OD x $\frac{5}{16}$ in. thick (deflector)		24	1
12012	Grommet — $\frac{5}{16}$ ID x $\frac{13}{16}$ OD x $\frac{5}{16}$ in. thick (inter ear deflector primer)		26	2
12012	Grommet — $\frac{5}{16}$ ID x $\frac{13}{16}$ OD x $\frac{5}{16}$ in. thick (inter ear deflector primer)		25	1
12012	Grommet — $\frac{5}{16}$ ID x $\frac{13}{16}$ OD x $\frac{5}{16}$ in. thick (deflector)		26	1
12012	Grommet — $\frac{5}{16}$ ID x $\frac{13}{16}$ OD x $\frac{5}{16}$ in. thick (inter ear deflector primer)		26	1
12012	Grommet — $\frac{5}{16}$ ID x $\frac{13}{16}$ OD x $\frac{5}{16}$ in. thick (inter ear deflector primer)		27	1
12012	Grommet — $\frac{5}{16}$ ID x $\frac{13}{16}$ OD x $\frac{5}{16}$ in. thick (inter ear deflector primer)		27	1
96125	Grommet — .345-.355 ID x .200-.206 in. long (spark plug elbow: for 5 m/m cable; detail of assembly No. 90461)		52	9
96125	Grommet — .345-.355 ID x .200-.206 in. long (spark plug elbow: for 5 m/m cable; detail of assembly No. 90456)		55	9
96347	Grommet — .503-.513 OD x .550 in. long (5 m/m spark plug lead at manifold outlet; detail of assembly No. 90461)		52	9
96347	Grommet — .503-.513 OD x .550 in. long (5 m/m spark plug lead at manifold outlet; detail of assembly No. 90456)		54	9
32383	Grommet — 7 m/m Spark plug lead at manifold outlet (detail of all assemblies except No. 90461)		52	9
32383	Grommet — 7 m/m Spark plug lead at manifold outlet (detail of all assemblies except No. 90456)		54	9
38674	Grommet — Spark plug elbow (for 7 m/m cable; detail of all assemblies except No. 90461 & 39650)		52	9
38674	Grommet — Spark plug elbow (for 7 m/m cable; detail of all assemblies except No. 90456 & 39649)		55	9

Parts Catalog

Part Number	Nomenclature	Figure Number	Page Number	Total Units Assy.
35850	Guard — Magneto conduit	13	54	1
35850	Guard — Magneto conduit	13	55	1
35851	Guard — Magneto conduit	13	54	1
24883	Guide — Deflector		24	1
24883	Guide — Deflector		26	1
†39495	Guide — Exhaust valve tappet (use (5) units on all engines except B4)	2	6	9
†39496	Guide — Exhaust valve tappet lower (for all engines except B4)	2	6	4
†39523	Guide — Exhaust valve	5	17	9
†3529	Guide — Intake valve	5	17	9
†39493	Guide — Intake valve tappet upper (use (5) units on all engines except B4) ...		5	9
†39494	Guide — Intake valve tappet lower (for all engines except B4)	2	6	4
24883	Guide — Inter cylinder deflector		22	7
24883	Guide — Inter cylinder deflector		24	1
24883	Guide — Inter cylinder deflector		26	2
24883	Guide — Inter cylinder deflector		25	1
24883	Guide — Inter cylinder deflector		26	1
24883	Guide — Inter cylinder deflector		27	1
24883	Guide — Inter cylinder deflector		27	1
24883	Guide — Inter cylinder deflector		27	1
49404	Guide — Inter cylinder deflector left hand		25	1
49405	Guide — Inter cylinder deflector right hand		25	1
H				
*39623	Head — Cylinder		17	9
14667	Hose — .750 ID x 1.625 in. long (cylinders No. 5 & 6; rocker box covers to rocker oil drain fitting; for all engines except B4)	7	30	2
39526	Hose — Inter cylinder oil drain pipe connection (use (4) units for all engines except B4)	5	21	8
38109	Hose — Inter ear oil drain pipe (use on cylinders No. 4, 5, 6 & 7; for all engines except B4)	5	20	9
119527	Housing — Generator drive (for use with Part No. 120645 housing assembly; for AN-1, -3, -14B & B5 only)		44	1
134891	Housing — Generator drive (for use with Part No. 135054 housing assembly; for all engines except B4; <i>supersedes No. 28626</i>)	9	44	1
5198	Housing — Left hand gun synchronizer	11	48	1
164315	Housing — Magneto drive oil seal (for use with magnetos having lip type oil seal)	10	46	2
9049	Housing — Oil pressure relief valve	10	43	1
5199	Housing — Right hand gun synchronizer	11	48	1
119528	Housing & Shaftgear Assembly — Generator drive (optional to Part No. 120645 generator drive; for B5 only)		44	1
120645	Housing & Shaftgear Assembly — Generator drive (for AN-1, -3, -14B & B5 having strengthened generator drive)		44	1
135054	Housing & Shaftgear Assembly — Generator drive (for all engines except B4 having old generator drives; <i>supersedes No. 1899</i>)		44	1
I				
12788	Impeller	8	34	1
19559	Impeller & Shaft Assembly — 10:1 (for all engines except B4)		34	1
81058	Impeller & Shaft Assembly — (for B4 only)		34	1
1177	Insert — Tachometer drive gear		45	1
J				
119526	Jaw — Generator drive, gear & starter (for use with Part No. 119528 housing assembly; for B5 only)		45	1
3277	Jaw — Starter (for installations requiring a three tooth jaw; for use with Part No. 135054 housing & shaftgear assembly generator drive)		44	1

Section III
Alphabetical Parts List

Parts Catalog

Part Number	Nomenclature	Figure Number	Page Number	Total Units Assy.
17090	Jaw — Starter (for installations requiring a three tooth jaw: for use with Part No. 120645 strengthened housing & shaftgear assembly generator drive; for AN-1, -3, -14B & B5 only)		44	1
24040	Jaw — Starter (for installations requiring a twelve tooth jaw)		44	1
21896	Jet — Collector section oil	8	30	1
23922	Jet — Crankshaft oil		12	1
80489	Journal — Impeller shaft (for B4 only)		34	1
K				
†224883	Key — Flat .125 x .150 x $\frac{3}{4}$ in. long (oil pressure pump gear; <i>supersedes No. 87</i>)	10	43	1
†224883	Key — Flat .125 x .150 x $\frac{3}{4}$ in. long (oil suction pump gear; <i>supersedes No. 87</i>)	10	41	1
†224884	Key — Flat .1275 x .141 x .312 in. long (oil suction pump; <i>supersedes No. 10128</i>)	10	41	1
†85	Key — Flat $\frac{3}{16}$ x $\frac{3}{32}$ x $1\frac{3}{32}$ in. long (fuel pump & gun control drive gear)	10	46	2
93	Key — Flat $\frac{1}{4}$ x .140 x 1 in. long (locks cam drive gear)		17	1
L				
35848	Lacing — Magneto conduit guard	13	54	1
35849	Lacing — Magneto conduit guard	13	54	1
35849	Lacing — Magneto conduit guard	13	56	1
49406	Latch — Inter cylinder deflector left hand	6	25	1
49407	Latch — Inter cylinder deflector right hand	6	25	1
57169	Lever — Propeller regulator valve (<i>supersedes No. 40098</i> for AN engines)	2	6	1
34461	Liner — Flyweight	4	12	2
†3559	Liner — Front main bearing	3	10	1
2630	Liner — Gun synchronizer bearing	10	46	2
*80484	Liner — Impeller shaft (for B4 only)		31	1
†9269	Liner — Rear main bearing	3	10	1
†37966	Liner — Thrust bearing	2	5	1
3561	Link — Engine lifting (use (2) units for all engines except B4)	3	11	4
*39782	Linkpin		16	1
†39785	Linkpin Assembly — 1.0594-1.0597 in. OD	4	16	8
*3469	Linkrod		17	8
3592	Linkrod Assembly	4	17	8
17018	Lock — .616 in. dia x .15" (intake valve)	5	19	18
9035	Lock — Collector drive retaining nut	8	34	1
39783	Lock — Linkpin	4	17	4
29410	Lockring — .576 OD x .048 in. thick (exhaust valve)	5	19	9
7920	Lockwasher — .194-.205 ID x .337 OD x .047-.057 in. thick (thermocouple clip bolt; <i>supersedes No. 188</i>)	5	22	1
7920	Lockwasher — .194-.205 ID x .337 OD x .047-.057 in. thick (magneto conduit elbow lock screw)	14	56	2
M				
27962	Magneto & Gear Assembly — (for use with Scintilla magnetos SB9RN)		56	2
28853	Magneto — SB9RN-4 (radio shielded fixed ignition left hand)	14	56	1
24437	Magneto — SB9RN-4 (radio shielded fixed ignition right hand)	14	56	1
27953	Magneto — Scintilla SB9RN	14	56	2
27961	Magneto & Shield Assembly — (for use with Scintilla magnetos SB9RN)		56	2
39489	Manifold Brazing Assembly — Rocker oil	2	6	1
33688	Manifold — Front ignition harness	13	50	1
33690	Manifold — Rear ignition harness	13	54	1
3708	Marker — Ignition cable (detail of all assemblies except No. 39650)	13	54	9
3708	Marker — Ignition cable (detail of all assemblies except No. 39649)	13	55	9
*39737	Masterod		15	1
128511	Masterod Assembly — (for B4 only)		15	1

Part Number	Nomenclature	Figure Number	Page Number	Total Units Assy.
†39787	Masterrod Assembly Complete — (for all engines except B4)		15	1
128512	Masterrod Assembly Complete — (for B4 only)		15	1
†39786	Masterrod Bearing Assembly — (for all engines except B4)	4	15	1
N				
127015	Neoprene Tape — (for service procurement)		56	40 ft.
5509	Nipple — Union .125-27 ANPT x .125 in. dia Tube (distributor end of primer tubing)	12	50	5
13842	Nozzle & Bracket Assembly — Collector oil pressure	8	34	1
14827	Nut — .562 Hexagon head x .4375-20 thd x .500 in. thick (primer distributor tubing coupling; for B4 & B5 engines only)	15	58	2
92368	Nut — .745-.755 Hexagon head x .438 in. thick (sparkplug conduit coupling)	13	52	18
92368	Nut — .745-.755 Hexagon head x .438 in. thick (sparkplug conduit coupling)	13	54	14
92368	Nut — .745-.755 Hexagon head x .438 in. thick (sparkplug conduit coupling)	13	54	2
92368	Nut — .745-.755 Hexagon head x .438 in. thick (sparkplug conduit coupling)	13	55	2
542	Nut — 3/4 Slotted hexagon head x 1/2-20 thd x 2 1/4 in. thick (starter shaft)	9	44	1
861	Nut — 2 1/2-12 thd (intake pipe packing)	8	35	9
23612	Nut — Anchor elastic stop 1/4-28 thd (deflector)		22	7
23612	Nut — Anchor elastic stop 1/4-28 thd (deflector)		24	1
23612	Nut — Anchor elastic stop 1/4-28 thd (deflector)		24	1
23612	Nut — Anchor elastic stop 1/4-28 thd (deflector)		26	2
23612	Nut — Anchor elastic stop 1/4-28 thd (deflector)		26	1
23612	Nut — Anchor elastic stop 1/4-28 thd (deflector)		26	1
23612	Nut — Anchor elastic stop 1/4-28 thd (deflector)		27	1
23612	Nut — Anchor elastic stop 1/4-28 thd (deflector)		27	1
23612	Nut — Anchor elastic stop 1/4-28 thd (deflector)		25	1
1012	Nut — Cam reduction gear	3	11	1
AN 121553	Nut — Castle .3125-24 thd x .328 in. thick (carburetor adapter to rear crankcase; <i>supersedes No. 511</i>)	15	57	2
502	Nut — Castled 7/16 Hexagon head x 1/4-28 thd x 9/32 in. thick (oil feed bracket bolts)		11	2
502	Nut — Castled .438 Hexagon head x .250-28 NF-3 thd x .282 in. thick (oil pump bolt; <i>use No. AS 100029 wire</i>)	10	41	4
502	Nut — Castled 7/16 Hexagon head x 1/4-28 thd x 9/32 in. thick (gun synchronizer)	11	48	1
511	Nut — Castled 1/2 Hexagon head x 5/16-24 thd x 2 1/4 in. thick (main crankcase to nose housing long stud; <i>use No. AS 100029 wire</i>)	2	8	1
528	Nut — Castled 3/8 in. Hexagon head x 3/8-16 thd (thrust cover stud; for B4 only)		8	2
533	Nut — Castled .4375-20 thd x .454 in. thick (main crankcase bolts)	3	11	8
533	Nut — Castled .4375-20 thd x .454 in. thick (blower spring drive bolt)	4	15	1
532	Nut — Castled 3/4 Hexagon head x 7/16-20 thd x 1 1/32 in. thick (valve rocker shaft)	5	20	18
*256309	Nut — Coupling		52	1
39575	Nut — Crankshaft front plug (for AN-14B, B3 & B5 only; contained in Part No. 39892 crankshaft assembly)	4	14	1
40355	Nut — Crankshaft front plug (for AN-14B, B3 & B5 only; contained in Part No. 42087 crankshaft assembly)	4	14	1
158189	Nut — Fibre .190-24 thd x .266 in. thick Special (inter ear oil drain pipe hose clamp)	5	20	18
158189	Nut — Fibre .190-24 thd x .266 in. thick Special (inter cylinder oil drain hose clamp)	5	21	16
158189	Nut — Fibre .190-24 thd x .266 in. thick Special (oil drain hose clamp screw)	7	30	4
158189	Nut — Fibre .190-24 thd x .266 in. thick Special (cylinder head oil drain clamp screw)		39	1
12856	Nut — Fibre insert 1/4-28 thd x 5/16 in. thick (propeller regulator valve cover)	2	6	4
12856	Nut — Fibre insert 1/4-28 thd x 5/16 in. thick (rockerbox cover)	5	21	72
12856	Nut — Fibre insert 1/4-28 thd x 5/16 in. thick (ignition manifold to crankcase stud brace screw)	13	56	4
12856	Nut — Fibre insert 1/4-28 thd x 5/16 in. thick (gun drive cover; for use with plain studs)	10	46	8

Section III
Alphabetical Parts List

Parts Catalog

Part Number	Nomenclature	Figure Number	Page Number	Total Units Assy.
12856	Nut — Fibre insert $\frac{1}{4}$ -28 thd x $\frac{5}{16}$ in. thick (vacuum pump drive cover; for use with plain studs)	10	47	4
33415	Nut — Fibre insert $\frac{5}{16}$ -24 thd x $\frac{23}{64}$ in. thick (front case to rear pipe flange; for B4 only)		8	2
33415	Nut — Fibre insert $\frac{5}{16}$ -24 thd x $\frac{23}{64}$ in. thick (inter ear deflectors to cylinder head attaching)	6	28	18
33415	Nut — Fibre insert $\frac{5}{16}$ -24 thd x $\frac{23}{64}$ in. thick (rocker oil drain fitting; for all engines except B4)	7	30	2
33415	Nut — Fibre insert $\frac{5}{16}$ -24 thd x $\frac{23}{64}$ in. thick (oil sump attaching studs)	7	30	4
33415	Nut — Fibre insert $\frac{5}{16}$ -24 thd x $\frac{23}{64}$ in. thick (rocker drain oil suction pipe; use (2) units for B4 rear oil scavenge pipe flange)	7	30	4
33415	Nut — Fibre insert $\frac{5}{16}$ -24 thd x $\frac{23}{64}$ in. thick (main oil suction pipe; use (2) units for B4 front case to rear pipe flange)	7	30	4
33415	Nut — Fibre insert $\frac{5}{16}$ -24 thd x $\frac{23}{64}$ in. thick (collector case blank flange; for B4 only)		35	2
33415	Nut — Fibre insert $\frac{5}{16}$ -24 thd x $\frac{23}{64}$ in. thick (intake pipe studs)		35	18
33415	Nut — Fibre insert $\frac{5}{16}$ -24 thd x $\frac{23}{64}$ in. thick (rear oil scavenge pipe flange; for B4 only)		39	2
33415	Nut — Fibre insert $\frac{5}{16}$ -24 thd x $\frac{23}{64}$ in. thick (rear oil drain pipe; use (2) units for B4)		40	4
33415	Nut — Fibre insert $\frac{5}{16}$ -24 thd x $\frac{23}{64}$ in. thick (rear case to collector)		40	15
33415	Nut — Fibre insert $\frac{5}{16}$ -24 thd x $\frac{23}{64}$ in. thick (oil pump)		43	5
33415	Nut — Fibre insert $\frac{5}{16}$ -24 thd x $\frac{23}{64}$ in. thick (oil connection shipping cover)		43	4
33415	Nut — Fibre insert $\frac{5}{16}$ -24 thd x $\frac{23}{64}$ in. thick (oil inlet cover)		43	2
33415	Nut — Fibre insert $\frac{5}{16}$ -24 thd x $\frac{23}{64}$ in. thick (generator drive cover)	9	45	4
33415	Nut — Fibre insert $\frac{5}{16}$ -24 thd x $\frac{23}{64}$ in. thick (fuel pump drive bracket)	10	48	4
33415	Nut — Fibre insert $\frac{5}{16}$ -24 thd x $\frac{23}{64}$ in. thick (fuel pump drive cover; for use with plain studs)	10	48	4
33415	Nut — Fibre insert $\frac{5}{16}$ -24 thd x $\frac{23}{64}$ in. thick (carburetor adapter to rear crankcase)	15	57	4
33415	Nut — Fibre insert $\frac{5}{16}$ -24 thd x $\frac{23}{64}$ in. thick (carburetor air screen; for engines using NA-R9B carburetors with $\frac{5}{16}$ -24 thd studs in the intake flange)	15	58	4
33415	Nut — Fibre insert $\frac{5}{16}$ -24 thd x $\frac{23}{64}$ in. thick (carburetor brackets; for NA-R9C2 carburetors)	15	58	4
26432	Nut — Fibre insert $\frac{3}{8}$ -24 thd x $\frac{29}{64}$ in. thick (nose section to main crankcase studs)	2	8	17
26432	Nut — Fibre insert $\frac{3}{8}$ -24 thd x $\frac{29}{64}$ in. thick (propeller thrust cover)	2	8	7
26432	Nut — Fibre insert $\frac{3}{8}$ -24 thd x $\frac{29}{64}$ in. thick (accessory pad cover)	9	44	6
26432	Nut — Fibre insert $\frac{3}{8}$ -24 thd x $\frac{29}{64}$ in. thick (carburetor to adapter)	15	58	4
11747	Nut — Fibre insert No. 8-36 thd x $\frac{15}{64}$ in. thick (cylinders No. 3 & 8; primer tubing clip screws)	12	50	2
11747	Nut — Fibre insert No. 8-36 thd x $\frac{15}{64}$ in. thick (suction pipe clamp screw)		56	1
11748	Nut — Fibre insert No. 10-32 thd x $\frac{19}{64}$ in. thick (breather connection clamp; for all engines except B4)		35	1
11748	Nut — Fibre insert No. 10-32 thd x $\frac{15}{64}$ in. thick (magneto conduit clamp screw)		52	1
11748	Nut — Fibre insert No. 10-32 thd x $\frac{15}{64}$ in. thick (magneto conduit clamp screw)		54	1
71148	Nut — Fibre insert anchor — Deflector		24	1
71148	Nut — Fibre insert — Deflector		25	1
5019	Nut — Floating gear & blower shaft retainer	8	34	1
34749	Nut — Front impeller shaft (for B4 only)		34	1
8232	Nut — Hydro propeller operating shaft packing (for AN engines only)	2	6	1
30604	Nut — Impeller	8	34	1
98997	Nut — Lock No. 6-32 thd (thermocouple wire terminal screw)	5	22	1
*88708	Nut — Magneto conduit coupling		52	2
214214	Nut — Nylon insert $\frac{1}{4}$ -28 x $\frac{5}{16}$ in. thick (gun drive cover; for use with plain or drilled studs; optional to Part No. 12856 nut)		46	8
AN 121502	Nut — Plain .250-28 thd x .219 in. thick (oil return check valve; <i>supersedes</i> No. 501)	9	43	1

Part Number	Nomenclature	Figure Number	Page Number	Total Units Assy.
AN 121502	Nut — Plain .250-28 thd x .219 in. thick (locks Part No. 43272 screw; <i>supersedes No. 501</i>)	10	43	1
520	Nut — Plain $\frac{3}{8}$ Hexagon head x No. 10-32 thd x $\frac{3}{16}$ in. thick (magneto shields attaching screws)	14	56	4
512	Nut — Plain $\frac{1}{2}$ Hexagon head x $\frac{5}{16}$ -24 thd x $1\frac{1}{64}$ in. thick (collector to main crankcase)		35	1
513	Nut — Plain $\frac{1}{2}$ Hexagon head x $\frac{5}{16}$ -24 thd x $\frac{3}{8}$ in. thick (exhaust port studs)		35	27
12009	Nut — Plain $\frac{1}{2}$ Hexagon head x $\frac{5}{16}$ -24 thd x $1\frac{3}{64}$ in. thick (nose section to Part No. 42422 main crankcase stud)		8	1
12009	Nut — Plain $\frac{1}{2}$ Hexagon head x $\frac{5}{16}$ -24 thd x $1\frac{3}{64}$ in. thick (rear case to collector)		40	1
110514	Nut — Plain .556 Hexagon head x $\frac{3}{8}$ -24 thd x .375 in. thick (cylinder flange; <i>supersedes No. 10449</i>)	5	21	90
4381	Nut — Plain $\frac{9}{16}$ Hexagon head x $\frac{3}{8}$ -24 thd x $2\frac{1}{64}$ in. thick (used with Part No. 38300 cowl stud)	2	8	6
4381	Nut — Plain $\frac{9}{16}$ Hexagon head x $\frac{3}{8}$ -24 thd x $2\frac{1}{64}$ in. thick (collector to main crankcase)		35	17
AN 121504	Nut — Plain $\frac{9}{16}$ Hexagon head x .375-24 thd x .328 in. thick (collector to main crankcase)		35	13
9294	Nut — Plain $\frac{3}{4}$ Hexagon head x $1\frac{19}{32}$ -24 thd x $\frac{5}{32}$ in. thick (valve adjusting screw lock)	5	19	9
534	Nut — Plain $2\frac{25}{32}$ Hexagon head x $\frac{7}{16}$ -14 thd x $\frac{7}{16}$ in. thick (engine mount bolt)		35	8
25050	Nut — Plain $2\frac{25}{32}$ Hexagon head x $\frac{7}{16}$ -14 thd x $\frac{9}{32}$ in. thick (engine mount bolt)		35	8
5453	Nut — Plain $1\frac{1}{16}$ Hexagon head x $\frac{3}{4}$ -16 thd x $\frac{5}{16}$ in. thick (front impeller shaft; for all engines except B4)	8	34	1
5032	Nut — Plain $1\frac{1}{8}$ Hexagon head x $\frac{1}{2}$ -20 thd x $\frac{5}{16}$ in. thick (collector intermediate gear)	8	33	1
523	Nut — Shear .562 Hexagon head x .375-24 thd x .328 in. thick (gun drive; <i>supersedes No. 23212</i>)	10	46	2
519	Nut — Slotted $\frac{5}{16}$ x .24 in. thick Special (oil pump)		43	1
18746	Nut — Spanner $1\frac{3}{16}$ -12 PD x $1\frac{1}{16}$ x $\frac{1}{4}$ in. thick (generator outboard bearing; for use with Part No. 120645 housing assembly; for AN-1, -3, -14B & B5 only)		45	1
11106	Nut — Spanner $1\frac{1}{4}$ -16 PD x $1\frac{3}{16}$ x $\frac{5}{16}$ in. thick (crankshaft oil pressure pipe rear; contained in Part No. 42087 crankshaft assembly)	4	14	1
29893	Nut — Sparkplug conduit coupling		52	9
29893	Nut — Sparkplug conduit coupling		54	7
29893	Nut — Sparkplug conduit coupling		55	1
29893	Nut — Sparkplug conduit coupling		55	1
9265	Nut — Upper & lower pushrod tube packing (<i>use No. AS 100029 wire</i>)	5	21	36
16405	Nut — Valve rocker shaft (for use with Part No. 126741, 126742 or 126834)		20	18
343986	Nut — Valve rocker shaft (for use with Part No. 399353, 399354 or 399355)	5	20	18
5610	Nut — Wing $\frac{1}{4}$ -20 thd x $1\frac{1}{16}$ in. thick (inter cylinder deflector — use (1) unit for B4 between cylinders No. 4-5 on Part No. 38987 plate & stud assembly; <i>use No. AS 100029 wire</i>)		28	3
P				
24230	Packing — $1\frac{19}{32}$ ID x $\frac{7}{8}$ OD x $\frac{5}{32}$ in. thick (oil pump body; <i>supersedes No. 71972</i>)		43	2
14096	Packing — 1.015 ID x 1.281 OD x .125 in. thick (pushrod tube inner; <i>supersedes No. 9282</i>)	5	21	36
121839	Packing — 1.005 ID x 1.285 OD x .400 in. thick (pushrod tube outer; <i>supersedes No. 88917</i>)	5	21	36
96122	Packing — For inside of sparkplug elbow when using 5 m/m cable (detail of assembly No. 90461)		52	9
96122	Packing — For inside of sparkplug elbow when using 5 m/m cable (detail of assembly No. 90456)		55	9
15008	Packing — Hydro valve (for AN engines only)	2	6	1

Section III
Alphabetical Parts List

Parts Catalog

Part Number	Nomenclature	Figure Number	Page Number	Total Units Assy.
863	Packing — Intake pipe	8	35	9
11468	Packing — Magneto shaft (for use with magnetos not having lip type oil seal)		47	2
AN 123867	Packing — Preformed .612 ID x .103 in. thick (valve rocker shaft; for use with Part No. 399353, 399354 or 399355)	5	20	18
818	Palnut — .500 in. Hexagon head x .3125-24 PD (nose section to Part No. 42422 main crankcase stud)		8	1
818	Palnut — .500 in. Hexagon head x .3125-24 PD (collector to main crankcase)		35	1
818	Palnut — .500 in. Hexagon head x .3125-24 PD (exhaust port studs)		35	27
818	Palnut — .500 in. Hexagon head x .3125-24 PD (rear case to collector)		40	1
7635	Palnut — .562 in. Hexagon head x .375-24 PD (cylinder flange)	5	21	90
7635	Palnut — .562 in. Hexagon head x .375-24 PD (collector to main crankcase)		35	17
45173	Pin — .0947-.0957 dia x .250 in. long (oil jet; for B4 only)		31	1
35081	Pin — .140 dia x 1 in. long (impeller nut)	8	34	1
46	Pin — .191 dia x .500 in. long — No. 60 Drill (crankshaft rear)		14	1
AN 122696	Pin — Dowel, steel .1250 dia x .875 in. long (oil pump idler gear to shaft; <i>supersedes No. 37</i>)	10	41	1
AN 122705	Pin — Dowel, steel .1875 dia x .500 in. long (collector bearing cover; <i>supersedes No. 7577; for B4 only</i>)		33	2
AN 122705	Pin — Dowel, steel .1875 dia x .500 in. long (collector bearing cover; <i>supersedes No. 7577; for all engines except B4</i>)		33	2
4614	Pin — Roller .1181 dia x .7795 in. long (collector drive floating gear)	8	34	79
1044	Pin — Roller .3125 dia x .781 in. long (valve tappet roller)	2	6	18
28	Pin — Straight .072 dia x .312 in. long (magneto oil shield; for use with magnetos not having lip type oil seal)		36	2
43567	Pin — Straight .072 dia x .125 in. long (tachometer inner; for AN engines only)		45	1
24	Pin — Straight .093 dia x .219 in. long (collector intermediate shaft ball bearing cage)	8	31	1
5709	Pin — Straight .0949 dia x 1.031 in. long (tachometer drive oil distributor)	10	46	2
5709	Pin — Straight .0949 dia x 1.031 in. long (tachometer drive oil distributor; for AN engines only)	10	46	1
30	Pin — Straight .098 dia x 1.375 in. long (front impeller shaft nut; for all engines except B4)	8	34	1
30	Pin — Straight .098 dia x 1.375 in. long (oil pressure pipe to bracket)	8	34	1
57852	Pin — Straight .0985 dia x .740 in. long (pressure pipe fastens rear crankcase; <i>supersedes No. 30</i>)		36	1
†15	Pin — Straight .1285 dia x .406 in. long (oil drain tube; for B4 only)		33	2
†15	Pin — Straight .1285 dia x .406 in. long (cam reduction gear bushing)		10	1
4229	Pin — Straight .1285 dia x .281 in. long (impeller shaft rear bearing; for B4 only)		31	1
43568	Pin — Straight .1285 dia x .344 in. long (impeller shaft front bearing; for B4 only)		31	1
46816	Pin — Straight .156 dia x .203 in. long (impeller cage; <i>supersedes No. 47</i>)		34	1
4199	Pin — Straight .156 dia x 1.031 in. long (oil pressure fitting)	8	30	1
25	Pin — Straight .165 dia x .500 in. long (fastens Part No. 1171 bushing)		36	2
7644	Pin — Straight .165 dia x .781 in. long (collector bearing cover; for all engines except B4)		33	2
39571	Pin — Straight .185 dia x 2.844 in. long (crankshaft plug; for AN-14B, B3 & B5 only; contained in Part No. 39892 crankshaft assembly)		12	1
†27	Pin — Straight .1885-.1890 dia x .500 in. long (front & rear main bearing liners)		10	8
44	Pin — Tapered .125 dia x .750 in. long (propeller regulator valve lever locking; for AN engines only)	2	6	1
17091	Pinion — Generator drive (for use with Part No. 120645 housing assembly; for AN-1, -3, -14B & B5 only)		45	1
1744	Pinion — Generator drive (for use with Part No. 135054 housing assembly; for all engines except B4)		44	1
39304	Pipe — ¼ ID x .312-.314 OD x 1 ¹⁵ / ₁₆ in. long (propeller regulator valve oil feed)	2	6	1
77766	Pipe Assembly — Breather (for B4 only)		6	1
39580	Pipe Assembly — Crankshaft (for AN-14B, B3 & B5 only; contained in Part No. 39892 crankshaft assembly)	4	14	1

Part Number	Nomenclature	Figure Number	Page Number	Total Units Assy.
40352	Pipe Assembly — Crankshaft (for AN-14B, B3 & B5 only; contained in Part No. 42087 crankshaft assembly)	4	14	1
74956	Pipe Assembly — Cylinder head oil drain (for B4 only)		39	1
74955	Pipe Assembly — Front case to rear (for B4 only)		8	1
†45535	Pipe Assembly — Inter ear oil drain (use on cylinders No. 4, 5, 6 & 7; for all engines except B4)	5	20	18
45941	Pipe Assembly — Main oil suction (for all engines except B4)	7	30	1
11045	Pipe Assembly — Oil thermometer connection		43	1
84623	Pipe Assembly — Oil thermostat connection (optional equipment)		43	1
9598	Pipe Assembly — Oil drain rear (for all engines except B4)	8	40	1
74957	Pipe Assembly — Rear oil scavenge (for B4 only)		39	1
51099	Pipe Assembly — Rocker drain oil suction (for all engines except B4)	7	30	1
19875	Pipe — Crankshaft	4	14	1
10262	Pipe — Crankshaft (for all engines except AN-14B, B3, B4 & B5)		12	1
10262	Pipe — Crankshaft (for B4 only; <i>supersedes No. 80985</i>)		14	1
1989	Pipe — Impeller air bleed (for all engines except B4)		30	2
70472	Pipe — Intake (<i>supersedes No. 7621</i>)	8	35	9
*13841	Pipe & Nozzle Assembly — Collector oil pressure		34	1
10268	Pipe — Oil feed upper	3	11	1
10897	Pipe — Oil pressure rear crankcase		36	1
10270	Pipe — Vertical propeller oil feed (for all engines except B4)	2	6	1
†27056	Piston — 6:1 (cylinders No. 1, 2, 3, 4, 7, 8 & 9)	5	20	7
†40698	Piston — 6:1 (cylinders No. 5 & 6)	5	26	2
*31740	Pistonpin		21	2
234221	Pistonpin Assembly — (<i>supersedes No. 31795</i>)	5	21	9
†188541	Pistonring — Compression (<i>supersedes No. 27057</i>)	5	20	18
†188538	Pistonring — Compression chrome plate (<i>supersedes No. 53616</i>)	5	20	9
†188542	Pistonring — Dual oil control (<i>supersedes No. 17097</i>)	5	21	18
†188546	Pistonring — Scraper (<i>supersedes No. 13681</i>)	5	21	9
49403	Plate Assembly — Inner cylinder deflector (for all engines except B4)	6	25	1
7072	Plate — Blower spring drive fixed	4	15	1
7073	Plate — Blower spring drive floating	4	14	1
134448	Plate — Company name (<i>supersedes No. 1196</i> ; for all engines except B4)	7	28	1
10414	Plate — Crankcase collector section (for all engines except B4)	8	33	2
10941	Plate — Data	11	48	1
35721	Plate — Engine data (for AN engines only)		8	1
37100	Plate — Engine data (for B3 & B5 only)		8	1
1742	Plate — Generator outboard bearing (for all engines except B4)	9	44	1
39377	Plate — Ignition harness data (detail of assembly No. 84462)	13	50	1
39377	Plate — Ignition harness data (detail of assembly No. 84463)	13	54	1
231626	Plate — Ignition manifold data (detail of assemblies No. 113811, 165376 or 47131)		50	1
231626	Plate — Ignition manifold data (detail of assemblies No. 113812, 165375 or 47132)		54	1
1921	Plate — Inspection port	11	48	1
49402	Plate — Inter cylinder deflector		25	1
73981	Plate — Inter cylinder deflector		24	7
73981	Plate — Inter cylinder deflector reinforcement		26	2
73981	Plate — Inter cylinder deflector reinforcement		26	1
73981	Plate — Inter cylinder deflector reinforcement		26	1
73981	Plate — Inter cylinder deflector reinforcement		27	1
73981	Plate — Inter cylinder deflector reinforcement		27	1
73989	Plate — Inter cylinder deflector reinforcement		24	1
73989	Plate — Inter cylinder deflector attaching		24	1
73990	Plate — Inter cylinder deflector reinforcement		27	1
73991	Plate — Inter cylinder deflector clamp		28	1
78928	Plate — Inter cylinder deflector reinforcing		24	1
78928	Plate — Inter cylinder deflector reinforcement		24	1
73981	Plate — Inter deflector reinforcement		25	1
*1579	Plate — Oil pump end		41	1
38987	Plate & Stud Assembly — Inter cylinder deflector clamp (use with cylinders No. 4-5 deflectors; for B4 only)		28	1

Section III
Alphabetical Parts List

Pratt & Whitney Aircraft
Parts Catalog

Part Number	Nomenclature	Figure Number	Page Number	Total Units Assy.
3649	Plate — Vane discharge	9	36	1
39749	Plug — $\frac{3}{8}$ Hollow hexagon x $\frac{11}{16}$ -16 thd x $\frac{3}{4}$ in. long (linkpin)		17	1
14320	Plug — $\frac{3}{4}$ Hexagon head x $\frac{11}{16}$ -24 x $\frac{11}{32}$ in. long (left hand magneto conduit elbow)		56	3
14320	Plug — $\frac{3}{4}$ Hexagon head x $\frac{11}{16}$ -24 x $\frac{11}{32}$ in. long (right hand magneto conduit elbow)		56	2
41514	Plug — .076 Square head x .750-14 Pipe x .962 in. long (gun drive left hand rear case; for B4 only)		36	1
17346	Plug — .281 Square head x .125-27 Pipe x .578 in. long (primer holes on spare cylinders)		20	9
17346	Plug — .281 Square head x .125-27 Pipe x .578 in. long (unused primer holes; cylinders No. 4, 5, 6 & 7)		21	4
17346	Plug — .281 Square head x .125-27 Pipe x .578 in. long (manifold pressure gauge connections)	8	31	3
17346	Plug — .281 Square head x .125-27 Pipe x .578 in. long (collector case; use No. AS 100029 wire)	8	35	1
17346	Plug — .281 Square head x .125-27 Pipe x .578 in. long (rear case; use (4) units for B4)		36	5
17346	Plug — .281 Square head x .125-27 Pipe x .578 in. long (unused holes in primer distributor; use No. AS 100029 wire)	12	50	4
19865	Plug — .438 Square head x .375-18 Pipe x .796 in. long (oil sump; use No. AS 100029 wire; for all engines except B4)		28	1
19865	Plug — .438 Square head x .375-18 Pipe x .796 in. long (rear case pressure pipe hole)	10	36	1
19865	Plug — .438 Square head x .375-18 Pipe x .796 in. long (rear case oil)	10	36	1
19865	Plug — .438 Square head x .375-18 Pipe x .796 in. long (swivel fitting; for all engines except B4)	10	39	2
91341	Plug — .438 Square head x .375-18 Pipe x .796 in. long (propeller governor oil pressure tube flange hole; use No. AS 100029 wire; for B3 & B5 only)	2	6	1
39579	Plug — .750 Hexagon head x .500-20 NF thd x .688 in. long (crankshaft front plug; for AN-14B, B3 & B5 only)	4	14	1
20126	Plug — 1 Hexagon head x No. 1-18 thd x $\frac{31}{32}$ in. long (oil sump drain; use No. AS 100029 wire; for all engines except B4)	7	28	2
20159	Plug — 1.000 Hexagon head x $1\frac{3}{8}$ -12 thd x $\frac{25}{32}$ in. long (front crankcase breather; for all engines except B4; use No. AS 100029 wire)	2	6	1
23256	Plug — $1\frac{1}{4}$ Hexagon head x 1-14 thd x $\frac{5}{8}$ in. long (sump oil strainer hole; for all engines except B4)	7	30	1
255	Plug — $1\frac{3}{8}$ -12 dia x $\frac{7}{16}$ in. long (collector case breather hole; use (1) unit for all engines except B4)	8	35	2
46255	Plug — $1\frac{1}{2}$ Hexagon head x $\frac{7}{8}$ -14 thd x $\frac{11}{16}$ in. long (swivel fitting; for all engines except B4)	10	39	2
12857	Plug — $1\frac{3}{4}$ -12 thd x $\frac{1}{2}$ in. long — No. 60 Drill (crankshaft inner)	4	14	1
39171	Plug — Cam plunger lock	11	48	1
39570	Plug — Crankshaft (for AN-14B, B3 & B5 only; contained in Part No. 39892 crankshaft assembly)	4	12	1
†44078	Plug — Crankshaft (for all engines except AN-14B, B3 & B5)	4	12	1
39574	Plug — Crankshaft front (for AN-14B, B3 & B5 only)	4	14	1
207098	Plug — Crankshaft front (for AN-14B, B3 & B5; for use in place of Part No. 39574 plug when any interference is encountered at installation)		14	1
56433	Plug — Cylinder dehydrator		22	18
149	Plug — Disc .625 dia x .064 in. long (oil pump)	10	41	1
132	Plug — Disc .625 dia x .064 in. long (oil pump)		43	2
91454	Plug — Hexagon socket .125 ANPT x .375 in. long Special (oil sump; supersedes No. 138 & 89884 for all engines except B4)	7	28	1
11521	Plug — Hexagon socket .125 in. ANPT (holes each side of cylinder No. 6 intake port)		31	2
11521	Plug — Hexagon socket .125 in. ANPT (rear case; use (8) units for B4)	10	36	9
138	Plug — Hexagon socket .125 in. ANPT (rear case; for B4 only)		36	1
138	Plug — Hexagon socket .125 in. ANPT (oil strainer inspection hole)		38	1
129	Plug — Hexagon socket .250 in. ANPT (rear crankcase)		36	2

Part Number	Nomenclature	Figure Number	Page Number	Total Units Assy.
134	Plug — Hexagon socket .375 in. ANPT (rockerbox cover; cylinders No. 1, 2, 3, 8 & 9; for all engines except B4)		20	10
91453	Plug — Hexagon socket .500 ANPT x .375 in. long Special (oil sump; <i>supersedes No. 89252</i> for all engines except B4)	7	28	3
136	Plug — Hexagon socket .750 ANPT x .500 in. long Special (rear crankcase)		36	3
13404	Plug — Oil pressure hole to right of vacuum pump drive pad (<i>use No. AS 100029 wire</i>)		43	1
234223	Plug — Pistonpin (<i>supersedes No. 9002</i>)	5	21	18
†15443	Plug — Plain slotted $\frac{5}{16}$ -18 thd x $\frac{1}{4}$ in. long (optional cowl attaching holes in nose housing)	2	8	4
†15443	Plug — Plain slotted $\frac{5}{16}$ -18 thd x $\frac{1}{4}$ in. long (rear case)		40	2
†19649	Plug — Plain slotted $\frac{1}{4}$ -20 thd x $\frac{1}{4}$ in. long (hole in cylinder No. 5 intake port)		31	1
131	Plug — Round head $\frac{5}{8}$ -18 thd x $\frac{3}{16}$ in. long (oil thermometer hole)		43	1
131	Plug — Round head $\frac{5}{8}$ -18 thd x $\frac{3}{16}$ in. long (carburetor ell cover; for AN engines only)		40	1
131	Plug — Round head $\frac{5}{8}$ -18 thd x $\frac{3}{16}$ in. long (oil inlet connection; <i>use No. AS 100029 wire</i>)		43	1
264399	Plug — Socket head .625-18 thd x .750 in. long (crankshaft plug; for all engines except AN-14, B3 & B5; <i>supersedes No. 44075</i>)	4	14	1
17038	Plug — Tachometer drive oil distributor		46	2
17038	Plug — Tachometer drive oil distributor (for AN engines only)		46	1
31346	Plug — Welch .593 in. dia (fuel pump drive gear)	10	48	1
257	Plug — Welch .875 in. dia (magneto drive shaft)	9	46	2
143	Plug — Welch 1.375 in. dia (oil sump; for all engines except B4)		28	1
1139	Plunger — Oil pressure relief valve	10	43	1
38366	Pump Assembly Complete — Oil (<i>supersedes No. 47563</i>)		41	1
86266	Pump Machining Assembly — Oil (<i>supersedes No. 38365</i>)	10	41	1
R				
5017	Race — Inner roller bearing floating gear	8	34	1
2651	Retainer — Bearing & cam gear	11	48	1
48390	Retainer — Oil strainer (for all engines except B4)	7	30	1
3036	Ring — Cam drive gear	3	11	1
†314047	Ring — Oil seal .093 ID x 3.216 OD x .101 in. thick (oil pump; <i>supersedes No. 8138</i>)		41	1
†33455	Ring — Oil seal 3.607 ID x 3.750 OD x .1845 in. thick (crankshaft thrust bearing spacer; use (1) unit for B4)	3	11	2
†6237	Ring — Oil seal — Oil feed bracket	3	11	2
34347	Ring — Propeller thrust bearing spacer	2	8	1
167	Rivet — .7485 dia x 1.305 in. long (counterweight short)		12	3
713	Rivet — .7485 dia x 1.210 in. long (counterweight)		12	1
747	Rivet — .7485 dia x 1.798 in. long (counterweight long)		12	3
749	Rivet — .9985 dia x 1.798 in. long (counterweight large diameter)		12	2
58332	Rivet — 100° Countersunk head x .126 dia x .313 in. long (deflector; <i>supersedes No. 58322</i>)		24	4
58332	Rivet — 100° Countersunk head x .126 dia x .313 in. long (deflector; <i>supersedes No. 58322</i>)		24	4
58329	Rivet — Brazier head .095 dia x .281 in. long (deflector)		22	18
57945	Rivet — Brazier head .095 dia x .250 in. long (deflector)		22	18
57945	Rivet — Brazier head .095 dia x .250 in. long (deflector)		24	28
57945	Rivet — Brazier head .095 dia x .250 in. long (deflector)		24	4
57945	Rivet — Brazier head .095 dia x .250 in. long (deflector)		24	4
57945	Rivet — Brazier head .095 dia x .250 in. long (deflector)		25	2
57945	Rivet — Brazier head .095 dia x .250 in. long (deflector)		25	4
57945	Rivet — Brazier head .095 dia x .250 in. long (deflector)		26	8
57945	Rivet — Brazier head .095 dia x .250 in. long (deflector)		26	4
57945	Rivet — Brazier head .095 dia x .250 in. long (deflector)		26	4
57945	Rivet — Brazier head .095 dia x .250 in. long (deflector)		27	4
57945	Rivet — Brazier head .095 dia x .250 in. long (deflector)		27	4
58328	Rivet — Brazier head .095 dia x .218 in. long (deflector)		22	45

Section III
Alphabetical Parts List

Pratt & Whitney Aircraft
Parts Catalog

Part Number	Nomenclature	Figure Number	Page Number	Total Units Assy.
58404	Rivet — Brazier head .095 dia x .344 in. long (deflector)		25	20
58322	Rivet — Brazier head .126 dia x .310 in. long (deflector)		24	56
58322	Rivet — Brazier head .126 dia x .310 in. long (deflector)		28	48
58323	Rivet — Brazier head .126 dia x .375 in. long (deflector)		24	4
58323	Rivet — Brazier head .126 dia x .375 in. long (deflector)		24	4
58323	Rivet — Brazier head .126 dia x .375 in. long (deflector)		25	2
58323	Rivet — Brazier head .126 dia x .375 in. long (deflector)		25	2
58321	Rivet — Brazier head .126 dia x .281 in. long (deflector)		24	6
58321	Rivet — Brazier head .126 dia x .281 in. long (deflector)		26	6
58322	Rivet — Brazier head .126 dia x .310 in. long (deflector)		22	27
58322	Rivet — Brazier head .126 dia x .310 in. long (deflector)		24	6
58322	Rivet — Brazier head .126 dia x .310 in. long (deflector)		24	3
58322	Rivet — Brazier head .126 dia x .310 in. long (deflector)		25	8
58322	Rivet — Brazier head .126 dia x .310 in. long (deflector)		26	16
58322	Rivet — Brazier head .126 dia x .310 in. long (deflector)		25	8
58322	Rivet — Brazier head .126 dia x .310 in. long (deflector)		26	8
58322	Rivet — Brazier head .126 dia x .310 in. long (deflector)		26	8
58322	Rivet — Brazier head .126 dia x .310 in. long (deflector)		27	8
58322	Rivet — Brazier head .126 dia x .310 in. long (deflector)		27	8
58322	Rivet — Brazier head .126 dia x .310 in. long (deflector)		28	3
58323	Rivet — Brazier head .126 dia x .375 in. long (deflector)		24	14
58323	Rivet — Brazier head .126 dia x .375 in. long (deflector)		26	4
58323	Rivet — Brazier head .126 dia x .375 in. long (deflector)		26	2
58323	Rivet — Brazier head .126 dia x .375 in. long (deflector)		26	2
58323	Rivet — Brazier head .126 dia x .375 in. long (deflector)		27	2
58323	Rivet — Brazier head .126 dia x .375 in. long (deflector)		27	2
58325	Rivet — Brazier head .126 dia x .562 in. long (deflector)		22	18
73995	Rivet — Brazier head .189 dia x .468 in. long (deflector)		22	18
35438	Rivet — Countersunk head .126 dia x .375 in. long (deflector)		25	4
35439	Rivet — Countersunk head $\frac{3}{32}$ dia $\frac{1}{4}$ in. long (deflector)		24	42
35439	Rivet — Countersunk head $\frac{3}{32}$ dia $\frac{1}{4}$ in. long (deflector)		24	2
35439	Rivet — Countersunk head $\frac{3}{32}$ dia $\frac{1}{4}$ in. long (deflector)		25	2
35439	Rivet — Countersunk head $\frac{3}{32}$ dia $\frac{1}{4}$ in. long (deflector)		25	6
35439	Rivet — Countersunk head $\frac{3}{32}$ dia $\frac{1}{4}$ in. long (deflector)		25	2
35439	Rivet — Countersunk head $\frac{3}{32}$ dia $\frac{1}{4}$ in. long (deflector)		26	12
35439	Rivet — Countersunk head $\frac{3}{32}$ dia $\frac{1}{4}$ in. long (deflector)		26	6
35439	Rivet — Countersunk head $\frac{3}{32}$ dia $\frac{1}{4}$ in. long (deflector)		26	6
35439	Rivet — Countersunk head $\frac{3}{32}$ dia $\frac{1}{4}$ in. long (deflector)		27	6
35439	Rivet — Countersunk head $\frac{3}{32}$ dia $\frac{1}{4}$ in. long (deflector)		27	6
35439	Rivet — Countersunk head $\frac{3}{32}$ dia $\frac{1}{4}$ in. long (deflector)		27	6
76785	Rivet — Countersunk head .095 dia x .313 in. long (deflector)		25	4
78858	Rivet — Flat head .186 dia x .375 in. long (magneto drive gear; <i>supersedes No. 151</i>)	9	46	12
156	Rivet — Round head .0937 dia x $\frac{23}{32}$ in. long (plate data)		8	4
153	Rivet — Round head .095 dia x .375 in. long (magneto drive cover; for use with magnetos not having lip type oil seal)		47	12
9317	Rivet — Round head .157 dia x $\frac{17}{64}$ in. long (cam assembly)	3	11	35
4486	Rivet — Round head $\frac{3}{32}$ dia x $\frac{3}{8}$ in. long (cam reduction gear; use (6) units for gears with 6 holes)	3	11	6
139479	Rivet — Universal head .094 dia x .250 in. long (deflector; <i>supersedes No. 57945</i>)		27	4
143575	Rivet — Universal head .095 dia x .219 in. long (deflector; <i>supersedes No. 58328</i>)		27	6
175147	Rivet — Universal head .095 dia x .375 in. long (for service procurement; for use with magnetos not having lip type oil seal)		47	12
126832	Rivet — Universal head .125 dia x .312 in. long (deflector; <i>supersedes No. 58322</i>)		27	2
204446	Rivet — Universal head .126 dia x .219 in. long (deflector; <i>supersedes No. 58227</i>)		24	35

Part Number	Nomenclature	Figure Number	Page Number	Total Units Assy.
204446	Rivet — Universal head .126 dia x .219 in. long (deflector; <i>supersedes No. 58227</i>)		24	5
204446	Rivet — Universal head .126 dia x .219 in. long (deflector; <i>supersedes No. 58227</i>)		24	5
204446	Rivet — Universal head .126 dia x .219 in. long (deflector; <i>supersedes No. 58227</i>)		25	5
204446	Rivet — Universal head .126 dia x .219 in. long (deflector; <i>supersedes No. 58227</i>)		26	10
204446	Rivet — Universal head .126 dia x .219 in. long (deflector; <i>supersedes No. 58227</i>)		26	5
204446	Rivet — Universal head .126 dia x .219 in. long (deflector; <i>supersedes No. 58227</i>)		26	5
204446	Rivet — Universal head .126 dia x .219 in. long (deflector; <i>supersedes No. 58227</i>)		27	5
204446	Rivet — Universal head .126 dia x .219 in. long (deflector; <i>supersedes No. 58227</i>)		27	5
204446	Rivet — Universal head .126 dia x .219 in. long (deflector; <i>supersedes No. 58227</i>)		27	5
126833	Rivet — Universal head .126 dia x .281 in. long (deflector; <i>supersedes No. 5832 for (4) units</i>)		27	28
126344	Rivet — Universal head .126 dia x .344 in. long (deflector)		28	2
12973	Rocker Assembly — Exhaust valve	5	19	9
12974	Rocker Assembly — Intake valve	5	19	9
*11476	Rocker — Exhaust valve large bearing type		19	9
*11475	Rocker — Intake valve large bearing type		19	9
45942	Rod Assembly — Push		21	18
39788	Rods Assembly Complete — Connecting (for all engines except B4)		15	1
128502	Rods Assembly Complete — Connecting (for B4 only)		15	1
39288	Rod — Intake & exhaust valve push	5	21	18
5999	Roller — Valve tappet	2	6	18
S				
*173595	Scoop — Inter cylinder deflector left half		27	1
*173596	Scoop — Inter cylinder deflector right half		27	1
59189	Screen Assembly — Oil (<i>supersedes No. 22545</i>)	9	43	1
6906	Screen — Carburetor air (for engines using NA-R9B carburetors)	15	58	1
39697	Screen — Carburetor air (for engines using NA-R9C2 carburetors)	15	58	1
74088	Screen — Inter cylinder deflector scoop		27	1
1175	Screw — $\frac{7}{16}$ -20 thd x $1\frac{15}{16}$ in. long (magneto drive shaft)	10	47	2
19575	Screw — $\frac{7}{16}$ Hexagon head drilled x $\frac{1}{4}$ -28 thd x $1\frac{1}{2}$ in. long (breather connection; for all engines except B4)	8	35	1
4669	Screw — $\frac{1}{2}$ Hexagon head drilled x $\frac{5}{16}$ -18 thd x $1\frac{5}{16}$ in. long (intake pipe; <i>use No. AS 100029 wire; supersedes No. 206</i>)		35	9
6277	Screw — $\frac{1}{2}$ Hexagon head drilled x $\frac{3}{16}$ -18 thd x $\frac{3}{8}$ in. long (carburetor air screen; for engines using NA-R9C2 carburetors & for engines using NA-R9B carburetors with $\frac{5}{16}$ -18 thd inserts in the intake flange)	15	58	4
8756	Screw — $\frac{9}{16}$ Hexagon head drilled x $\frac{3}{8}$ -16 thd x 1 in. long (magneto; <i>use No. AS 100029 wire</i>)		56	6
127599	Screw Assembly — Valve clearance adjusting (<i>supersedes No. 9514</i>)	5	19	9
220	Screw — Fillister head No. 8-32 thd x $\frac{1}{4}$ in. long (crankshaft front plug; <i>use No. AS 100029 wire; for AN-14B, B3 & B5 only</i>)	4	14	3
158188	Screw — Fillister head .190-24 x 1.000 in. long Special (inter ear oil drain pipe hose clamp)	5	20	18
220	Screw — Fillister head No. 8-32 thd x $\frac{1}{4}$ in. long (gun synchronizer; <i>use No. AS 100029 wire</i>)	11	48	2
7921	Screw — Fillister head No. 10-24 thd x .373 in. long (magneto conduit elbow lock)	14	56	2
20228	Screw — Fillister head No. 10-24 thd x 1.500 in. long (primer distributor to cylinder No. 1 intake pipe; <i>use No. AS 100029 wire</i>)	12	50	2

Section III
Alphabetical Parts List

Pratt & Whitney Aircraft
Parts Catalog

Part Number	Nomenclature	Figure Number	Page Number	Total Units Assy.
202	Screw — Fillister head drilled $\frac{1}{4}$ -20 thd x $\frac{9}{16}$ in. long (oil pressure pipe bracket; use No. AS 100029 wire)	3	11	2
202	Screw — Fillister head drilled $\frac{1}{4}$ -20 thd x $\frac{9}{16}$ in. long (oil bracket to collector housing; use No. AS 100029 wire)	8	34	2
202	Screw — Fillister head drilled $\frac{1}{4}$ -20 thd x $\frac{9}{16}$ in. long (main crankcase oil pressure fitting; use No. AS 100029 wire)	3	10	2
202	Screw — Fillister head drilled $\frac{1}{4}$ -20 thd x $\frac{9}{16}$ in. long (tachometer coupling; use No. AS 100029 wire; for B3, B4 & B5 only)	9	45	4
202	Screw — Fillister head drilled $\frac{1}{4}$ -20 thd x $\frac{9}{16}$ in. long (impeller cage; use No. AS 100029 wire)	8	33	8
202	Screw — Fillister head drilled .250-20 NC thd x .562 in. long (generator out-board bearing plate; use No. AS 100029 wire; for all engines except B4)	9	44	4
202	Screw — Fillister head drilled $\frac{1}{4}$ -20 thd x $\frac{9}{16}$ in. long (magneto drive cover; use No. AS 100029 wire)	10	47	8
202	Screw — Fillister head drilled $\frac{1}{4}$ -20 thd x $\frac{9}{16}$ in. long (collector bearing cover; use No. AS 100029 wire; for all engines except B4)	8	34	8
285	Screw — Fillister head drilled $\frac{1}{4}$ -20 thd x $2\frac{3}{32}$ in. long (gun synchronizer)	11	48	4
6263	Screw — Fillister head drilled $\frac{1}{4}$ -20 thd x $\frac{7}{16}$ in. long (carburetor ell cover; use No. AS 100029 wire; for B3, B4 & B5 only)	10	40	3
8812	Screw — Fillister head drilled $\frac{5}{16}$ -18 thd x $1\frac{1}{16}$ in. long (oil feed bracket; use No. AS 100029 wire)	3	11	6
14548	Screw — Fillister head drilled $\frac{1}{4}$ -20 thd x $1\frac{5}{32}$ in. long (tachometer coupling; use No. AS 100029 wire; for AN engines only)	9	45	4
39710	Screw — Fillister head drilled $\frac{1}{4}$ -20 thd x $\frac{3}{4}$ in. long (for engines having crankcases with tapped holes in front of the valve tappet guide bosses & opposing holes in the valve tappet guides)		8	18
39748	Screw — Fillister head drilled $\frac{5}{16}$ -24 thd x $\frac{3}{8}$ in. long (link in)	4	17	8
44107	Screw — Fillister head drilled $\frac{1}{4}$ -20 thd x $\frac{7}{16}$ in. long (carburetor ell cover; use No. AS 100029 wire; for AN engines only)		40	3
AN 115808	Screw — Flat fillister drilled head .190(10)-32NF-3A thd x .438 in. long (crankcase collector section plate; use No. 192 wire; supersedes No. 282; for all engines except B4)	8	33	4
22374	Screw — Flat fillister head No. 10-32 thd x $\frac{9}{32}$ in. long (spline locating)	4	12	1
24929	Screw — Flat fillister head $\frac{1}{4}$ -20 thd x $\frac{7}{16}$ in. long (rear case)		36	2
38602	Screw — Flat fillister head $\frac{1}{4}$ -20 thd x $\frac{9}{16}$ in. long (impeller cover; for B4 only)		33	8
299	Screw — Flat head $\frac{7}{16}$ -24 thd x $\frac{3}{4}$ in. long (crankshaft rear gear)	4	14	4
215	Screw — Flat head No. 8-32 thd x $\frac{5}{16}$ in. long (name plate mount disc; for all engines except B4)	7	28	4
7359	Screw — Flat head No. 10-32 thd x $\frac{1}{2}$ in. long (vane discharge plate; supersedes No. 214)	9	38	7
23902	Screw — Flyweight	4	12	2
158188	Screw — Cylinder head oil drain clamp		39	1
158188	Screw — Inter cylinder oil drain hose clamp	5	21	16
158188	Screw — Oil drain hose clamp	7	30	4
43272	Screw — Oil pressure relief valve adjusting	10	43	1
39490	Screw — Rocker oil manifold (use No. AS 100029 wire)	2	6	9
39491	Screw — Rocker oil manifold (use No. AS 100029 wire)	2	6	9
12079	Screw — Round head No. 10-32 thd x $\frac{3}{4}$ in. long (magneto conduit clamp)		52	1
12079	Screw — Round head No. 10-32 thd x $\frac{3}{4}$ in. long (magneto conduit clamp)		52	1
23000	Screw — Round head No. 8-36 thd x $\frac{1}{2}$ in. long (cylinders No. 3 & 8 primer tubing clips; supersedes No. 42016)	12	50	2
8650	Screw — Round head No. 6-32 thd x 1 in. long (primer tubing to intake pipe clamps)	12	50	10
98996	Screw — Round head No. 6-32 thd x .312 in. long (thermocouple wire terminal)	5	22	1
208	Screw — Round head No. 8-32 thd x $\frac{1}{4}$ in. long (gun synchronizer)	11	48	2
19727	Screw — Round head No. 8-36 thd x $\frac{3}{8}$ in. long (suction pipe clamp)		56	1
729	Screw — Round head No. 10-32 thd x $\frac{3}{8}$ in. long (deflector)		25	1
265149	Screw — Round head No. 10-32 thd x $\frac{1}{2}$ in. long (deflector; supersedes No. 13705)		24	1

Part Number	Nomenclature	Figure Number	Page Number	Total Units Assy.
265149	Screw — Round head No. 10-32 thd x ½ in. long (deflector; <i>supersedes No. 13705</i>)		25	1
265149	Screw — Round head No. 10-32 thd x ½ in. long (breather connection clamp; <i>supersedes No. 13705</i> ; for all engines except B4)		35	1
21027	Screw — Round head No. 10-32 thd x 5/16 in. long (thermocouple holes)		20	9
31724	Seal — .375 ID x .080 in. thick (valve rocker shaft)	5	20	18
44076	Seal — .438 ID x .125 in. thick (front crankshaft plug; for all engines except AN-14B, B3 & B5)	4	14	1
44076	Seal — .438 ID x .125 in. thick (collector case to rear case oil drain tube; for use with Part No. 126310 collector case)		33	1
44076	Seal — .438 ID x .125 in. thick (oil pressure tube oil; for use with Part No. 123724 rear case & studs assembly; for B4 only)		40	1
30489	Seal — .500 ID x .625 OD x .047 in. thick (valve rocker shaft; for use with Part No. 126741, 126742 or 126834)		20	18
33891	Seal — .656 ID x .094 in. thick (main crankcase halves around Part No. 4447 stud)	3	11	1
33891	Seal — .656 ID x .094 in. thick (collector breather plug; use (1) unit for all engines except B4)	8	35	2
36090	Seal — .750 ID x .125 in. thick (collector case to rear case oil drain tube; for use with Part No. 126310 collector case)		33	2
36090	Seal — .750 ID x .125 in. thick (magneto bushing oil; for use with Part No. 123724 rear case & studs assembly; for B4 only)		40	2
28955	Seal — 1.156 ID x .125 in. thick (starter bushing oil; for use with Part No. 123724 rear case & studs assembly; for B4 only)		40	1
23435	Seal — 1.688 ID x .141 in. thick (oil return check valve)	9	43	1
31123	Seal — 2.500 ID x 2.542 OD x .021 in. thick (generator drive; for all engines except B4)		44	1
14438	Seal — 4.625 ID x .113 in. dia Round (cylinder barrel)	5	21	9
14438	Seal — 4.625 ID x .113 in. dia Round (impeller shaft bearing cover; for B4 only)		33	1
38606	Seal — 16.625 ID x .125 in. dia Round (nose housing to main crankcase; <i>supersedes No. 12584</i>)	2	8	1
38606	Seal — 16.625 ID x .125 in. dia Round (collector to main crankcase; <i>supersedes No. 12584</i>)	8	35	1
106233	Seal — Inter cylinder deflector right		25	1
106234	Seal — Inter cylinder deflector left		25	1
287780	Seal — Oil .875 ID x 1.379 OD x .375 in. thick (vacuum pump gear; <i>supersedes No. 287792</i>)	10	47	1
288045	Seal — Oil .750 ID x 1.379 OD x .312 in. wide (fuel pump drive shaft; <i>supersedes No. 37819</i>)	10	47	1
383021	Seal — Oil .875 ID x 1.754 OD x .250 in wide (magneto housing; for use with magnetos having lip type oil seal; <i>supersedes No. 164314</i>)	10	46	2
87241	Seal — Oil 1.032 ID x 2.004 OD x .750 in. thick (impeller shaft oil; for B4 only)		33	1
287788	Seal Option — Tachometer drive (procurement number consists of: Part No. 14538 & 287778 seal)	9	45	2
†20786	Seal — Exhaust valve	5	17	9
†3500	Seat — Intake valve	5	17	9
22897	Seat — Oil return check valve	9	43	1
81170	Shaft Assembly — Impeller (for B4 only)		34	1
10545	Shaft Assembly — Magneto drive	9	46	2
15937	Shaft Assembly — Valve rocker; <i>supersedes No. 45937</i>)	5	19	18
*2627	Shaft — Gun control tachometer drive gear		45	2
*5205	Shaft — Gun control tachometer drive gear (for AN engines only)		46	1
6514	Shaft — Impeller (for all engines except B4)	8	34	1
*80487	Shaft — Impeller (for B4 only)		34	1
10538	Shaft — Magneto drive		46	2
19149	Shaft — Oil control valve (for AN engines only)	2	6	1
38364	Shaft — Oil pump idler	10	41	1
*40052	Shaft — Valve rocker		19	18

Section III
Alphabetical Parts List

Parts Catalog

Part Number	Nomenclature	Figure Number	Page Number	Total Units Assy.
119525	Shaftgear — Generator drive (for use with Part No. 119528 housing assembly; for B5 only)		45	1
5484	Shield Assembly — Magneto (Scintilla SB9RN)		56	2
5484-1	Shield — Magneto	14	56	2
5484-2	Shield — Magneto	14	56	2
1108	Shield — Magneto drive oil (for use with magnetos not having lip type oil seal)		46	2
2634	Shim — Cam adjusting	11	48	1
96124	Sleeve — .200-.208 ID x 2.500 in. long (magneto end of 5 m/m sparkplug cable waterproof; detail of assembly No. 90461)		54	9
96124	Sleeve — .200-.208 ID x 2.500 in. long (magneto end of 5 m/m sparkplug cable waterproof; detail of assembly No. 90456)		55	9
A-22883	Sleeve Adapter — (Titeflex; for service procurement)		56	18
B-25697	Sleeve — Sparkplug barrel sealing (Titeflex; for service procurement)		56	18
1020	Slinger — Propeller thrust bearing oil	2	8	1
33784	Socket — Pushrod ball	2	6	18
18169	Spacer — .104 ID x .188 OD x .125 in. thick (data plate)		8	4
43982	Spacer — .266 ID x .500 OD x .234 in. thick (gun drive cover; use (4) units for AN engines)		46	8
48601	Spacer — .344 ID x .688 OD x .406 in. thick (for use when installing NA-R9B carburetors on rear sections studded for NA-R9C2 carburetors)	15	58	2
16028	Spacer — .391 ID x .688 OD x .312 in. thick (thrust cover)	2	8	7
3555	Spacer — $\frac{37}{64}$ ID x $\frac{25}{32}$ OD x $\frac{9}{16}$ in. thick (gun control shaft; use (1) unit for AN-4, -6, -6B, -10, -12, -12B & -14B)	10	46	2
35140	Spacer — .875 ID x 1.438 OD x .109 in. thick (vacuum pump gear)	10	47	1
156010	Spacer — 1.040-1.080 ID x 1.996-2.000 OD x .010-.020 in. thick (name plate mount disc)	7	28	1
81189	Spacer Assembly — Crankshaft thrust bearing (for all engines except B4)		11	1
110019	Spacer Assembly — Crankshaft thrust bearing (for B4 only)		11	1
128648	Spacer — Carburetor shipping		58	2
5033	Spacer — Collector intermediate bearing	8	33	1
†1578	Spacer — Crankshaft adjusting	3	12	1
10266	Spacer — Crankshaft thrust bearing	3	11	1
5018	Spacer — Floating gear end thrust	8	34	1
5018	Spacer — Floating gear end thrust	8	34	1
17089	Spacer — Generator drive (for use with Part No. 120645 housing assembly; for AN-1, -3, -14B & B5 only)		45	1
80490	Spacer — Impeller shaft rear (for B4 only)		34	1
†121208	Spacer — Magneto bushing oil (for use with Part No. 123724 rear case & studs assembly; for B4 only)		40	2
†121209	Spacer — Oil pressure tube oil (for use with Part No. 123724 rear case & studs assembly; for B4 only)		40	1
10942	Spacer — Plain $\frac{1}{4}$ ID x .551 OD x .040 in. thick (pushrod; spares assemblies are shipped with (2) units)	5	21	18
†8711	Spacer — Rear collector shaft oil (for all engines except B4)	8	34	1
†121207	Spacer — Starter bushing oil (for use with Part No. 123724 rear case & studs assembly; for B4 only)		39	1
1335	Spacer — Starter gear	8, 9	44	1
1741	Spannernut — $1\frac{3}{16}$ -12 PD x $1\frac{9}{16}$ x $\frac{1}{4}$ in. thick (generator outboard bearing; for use with Part No. 135054 housing assembly; for all engines except B4)	9	45	1
1019	Spannernut — $2\frac{3}{4}$ -12 PD x 3.600 x $\frac{1}{2}$ in. thick (propeller thrust bearing)	2	8	1
128095	Sparkplug — BG-RB485S (optional procurement)		22	18
158365	Sparkplug — BG-706SR (optional procurement)		22	18
137705	Sparkplug — Champion RC-26-S (optional procurement)		22	18
303758	Sparkplug — Rem 39N (optional to Part No. 137705, 128095 or 158365)		22	18
22896	Spring — .350 OD x .038 in. dia Wire (oil return check valve)	9	43	1
981	Spring — 1.020 OD x .041 dia Wire x .205 in. long Free length compression (packing adjusting; for use with magnetos not having lip type oil seal)		46	2
28161	Spring — 1.600 OD x .154 in. dia Wire (intake valve inside)	5	19	9
2604	Spring — 1.600 OD x .162 in. dia Wire (exhaust valve inside)	5	19	9
2603	Spring — 1.683 ID x .192 in. dia Wire (exhaust valve outside)	5	19	9

Part Number	Nomenclature	Figure Number	Page Number	Total Units Assy.
28160	Spring — 1.683 ID x .183 in. dia Wire (intake valve outside)	5	19	9
12678	Spring — Blower spring drive	4	15	7
14013	Spring — Deflector	6	22	7
14013	Spring — Deflector	6	24	1
14013	Spring — Deflector	6	24	1
14013	Spring — Deflector	6	26	2
14013	Spring — Deflector	6	25	1
14013	Spring — Deflector	6	26	1
14013	Spring — Deflector	6	26	1
14013	Spring — Deflector	6	27	1
14013	Spring — Deflector	6	27	1
14013	Spring — Deflector	6	27	1
35431	Spring — Dzus fastener — Deflector		25	2
93314	Spring — Inter cylinder deflector guide	6	25	2
6091	Spring — Oil pressure relief valve	10	43	1
106230	Stiffener — Inter cylinder deflector left hand		25	1
106229	Stiffener — Inter cylinder deflector right hand		25	1
1149	Strainer — Oil sump (for all engines except B4)	7	30	1
115684	Strip Assembly — Inter cylinder deflector joining right (for all engines except B4)		25	1
73988	Strip — Inter cylinder deflector bearing right		22	7
73988	Strip — Inter cylinder deflector bearing right		24	1
73988	Strip — Inter cylinder deflector bearing right		24	1
73988	Strip — Inter cylinder deflector bearing right		26	2
73988	Strip — Inter cylinder deflector bearing right		25	1
73988	Strip — Inter cylinder deflector bearing right		26	1
73988	Strip — Inter cylinder deflector bearing right		26	1
73988	Strip — Inter cylinder deflector bearing right		27	1
73988	Strip — Inter cylinder deflector bearing right		27	1
73988	Strip — Inter cylinder deflector bearing		27	1
151627	Strip — Inter cylinder deflector bearing left		22	7
151627	Strip — Inter cylinder deflector bearing left		24	1
151627	Strip — Inter cylinder deflector bearing left		24	1
151627	Strip — Inter cylinder deflector bearing left		26	2
151627	Strip — Inter cylinder deflector bearing left		25	1
151627	Strip — Inter cylinder deflector bearing left		26	1
151627	Strip — Inter cylinder deflector bearing left		26	1
151627	Strip — Inter cylinder deflector bearing left		27	1
151627	Strip — Inter cylinder deflector bearing left		27	1
143774	Strip — Inter cylinder deflector bearing		27	1
74016	Strip — Inter cylinder deflector nose blank		22	7
74016	Strip — Inter cylinder deflector nose		25	1
74016	Strip — Inter cylinder deflector nose blank		26	2
74016	Strip — Inter cylinder deflector nose blank		26	1
74016	Strip — Inter cylinder deflector nose blank		26	1
74016	Strip — Inter cylinder deflector nose		27	1
74016	Strip — Inter cylinder deflector nose blank		27	1
74016	Strip — Inter cylinder deflector nose blank		27	1
74017	Strip — Inter cylinder deflector nose right		25	1
74018	Strip — Inter cylinder deflector nose left hand		25	1
106231	Strip — Inter cylinder deflector right		25	1
106232	Strip — Inter cylinder deflector left		25	1
115683	Strip — Inter cylinder deflector joining left		25	1
4447	Stud — Double shouldered $\frac{3}{16}$ -24 & $\frac{5}{16}$ -24 thd x $9\frac{1}{32}$ in. long (main crankcase sections attaching to nose section)	3	11	1
†5206+4	Stud — Drilled .250-20-28 thd x 2.578 in. long (gun synchronizer right hand; for AN engines only)	10	38	4
†43613	Stud — Drilled $\frac{1}{4}$ -20-28 thd x 1.250 in. long (governor pad; use with Part No. 502 nut)		38	8
†626+4	Stud — Drilled .3125-18-24 thd x 1.500 in. long (carburetor adapter)	10	38	2

Section III
Alphabetical Parts List

Parts Catalog

Part Number	Nomenclature	Figure Number	Page Number	Total Units Assy.
†26264+4	Stud — Drilled .3125-18-24 thd x 1.781 in. long (generator; for AN engines)	9	39	4
†123441+4	Stud — Drilled .3125-18-24 thd x 1.562 in. long (fuel pump; <i>supersedes</i> No. 37812)	10	47	4
†77765+4	Stud — Drilled .375-16-24 thd x 3.060 in. long (thrust cover; for B4 only)		5	2
†12088+4	Stud — Fitted ¼-20-28 thd x 1½ in. long (propeller regulator valve; for all engines except B4)	2	5	2
20251	Stud — Inter cylinder deflector clamp		28	1
†12089+4	Stud — Plain .250-20-28 thd x 1.125 in. long (propeller regulator valve; for all engines except B4)	2	5	2
†15072+4	Stud — Plain .250-20-28 thd x 1.125 in. long (rockerbox cover)	5	19	72
†28255+4	Stud — Plain .250-20-28 thd x 1.188 in. long (propeller regulator valve cover; for B4 only)		5	4
†77913+4	Stud — Plain ¼-20-28 thd x 1.380 in. long (gun synchronizer; <i>supersedes</i> No. 43613; for B3 & B5 only; use (4) units on the left hand side for AN & B4 engines; use with Part No. 12856 & 214219 nut)	9, 10	38	8
†123423+4	Stud — Plain .250-20-28 thd x 1.750 in. long (vacuum pump; <i>supersedes</i> No. 35142)	10	39	4
†89102	Stud — Plain .3125-18-24 thd x 1.438 in. long (collector to rear case; <i>supersedes</i> No. 625; use (7) units for B-5)		31	9
†625+4	Stud — Plain .3125-18-24 thd x 1.500 in. long (exhaust & intake flange)	5	19	45
†656+4	Stud — Plain .3125-18-24 thd x 1.625 in. long (fuel pump)	10	38	4
†658+4	Stud — Plain .3125-18-24 thd x 1.938 in. long (carburetor adapter; for engines using NA-R9C2 carburetors)		38	2
†7959+4	Stud — Plain .3125-18-24 thd x 1.844 in. long (collector to rear case)		31	3
†9085+4	Stud — Plain .3125-18-24 thd x 1.375 in. long (collector to rear case)		31	1
†9085+4	Stud — Plain .3125-18-24 thd x 1.375 in. long (generator; for B4 only)		39	4
†9252+4	Stud — Plain .3125-18-24 thd x 2.094 in. long (oil sump fastening; for all engines except B4)		31	2
†9385+4	Stud — Plain .3125-18-24 thd x 2.281 in. long (collector to rear case)		31	1
†11345+4	Stud — Plain .3125-18-24 thd x 1.562 in. long (collector to rear case; use (2) units for all engines except B3 & B5)		31	4
†11345+4	Stud — Plain .3125-18-24 thd x 1.562 in. long (carburetor adapter; for engines using NA-R9B carburetors; use (2) units for engines using NA-R9C2 carburetors)	10	38	4
†12054+4	Stud — Plain .3125-18-24 thd x 1.250 in. long (deflector fastening)	5	19	18
†12054+4	Stud — Plain .3125-18-24 thd x 1.250 in. long (oil drain pipe connection)		31	2
†12055+4	Stud — Plain .3125-18-24 thd x 1.875 in. long (oil sump fastening; for all engines except B4)	2	5	2
†12086+4	Stud — Plain .3125-18-24 thd x 2.000 in. long (generator; for B3 & B5 only)	9	39	4
†12317+4	Stud — Plain .3125-18-24 thd x 1.312 in. long (rear oil pump oil scavenge pipes; for all engines except B4)	7	30	4
†12317+4	Stud — Plain .3125-18-24 thd x 1.312 in. long (oil pipe connection; <i>supersedes</i> No. 12054)	10	38	6
†12317+4	Stud — Plain .3125-18-24 thd x 1.312 in. long (oil suction pipe; <i>supersedes</i> No. 12054)		41	2
†12317+4	Stud — Plain .3125-18-24 thd x 1.312 in. long (oil inlet connection)	10	41	2
†19868+4	Stud — Plain .3125-18-24 thd x 2.375 in. long (oil pump)	10	38	4
†23299+4	Stud — Plain .3125-18-24 thd x 3.125 in. long (oil pump)	10	38	2
†35807+4	Stud — Plain .3125-18-24 thd x 1.390 in. long (carburetor bracket top)		58	1
†35809+4	Stud — Plain .3125-18-24 thd x 2.328 in. long (carburetor bracket)		58	1
†35810+4	Stud — Plain .3125-18-24 thd x 1.453 in. long (carburetor bracket)		58	1
†39079+4	Stud — Plain .3125-18-24 thd x 1.438 in. long (rocker oil drain fitting; <i>supersedes</i> No. 9085; for all engines except B4)	7	28	2
†40180+4	Stud — Plain .3125-18-24 thd x 1.516 in. long (carburetor bracket; for engines using NA-R9C2 carburetors)		38	1
†58843+4	Stud — Plain .3125-18-24 thd x 1.42 in. long (propeller regular valve; for B4 only)		5	2
†90105+4	Stud — Plain .3125-18-24 thd x 2.094 in. long (oil sump fastening; for B4 only)		31	2
†90106+4	Stud — Plain .3125-18-24 thd x 1.875 in. long (oil sump fastening; for B4 only)		5	2
†12057+4	Stud — Plain .375-16-24 thd x 1.938 in. long (main crankcase to blower)	3	10	17

Part Number	Nomenclature	Figure Number	Page Number	Total Units Assy.
†12081+4	Stud — Plain .375-16-24 thd x 1.562 in. long (cylinder flange)	3	10	90
†12082+4	Stud — Plain .375-16-24 thd x 1.531 in. long (starter)	9	38	2
†12091+4	Stud — Plain .375-16-24 thd x 1.781 in. long (starter)	9	38	4
†12091+4	Stud — Plain .375-16-24 thd x 1.781 in. long (carburetor)	15	57	4
†38300+4	Stud — Plain .375-16-24 thd x 2.156 in. long (main crankcase to nose section special cowl attaching)	3	10	6
†42419+4	Stud — Plain $\frac{3}{8}$ -16-24 thd x 2 $\frac{3}{8}$ in. long (thrust cover; use (5) units for B4)	2	5	7
†54610+4	Stud — Plain $\frac{3}{8}$ -16-24 thd x 1.75 in. long (main crankcase to nose housing; supersedes No. 15274)	3	10	11
A-25696	Stud — Sparkplug connector (Tireflex; for service procurement)		56	18
†12085+4	Stud — Stepped .375-16 & .3125-24 thd x 1.625 in. long (oil sump attaching)	3	10	1
†42422+4	Stud — Stepped .375-16 & .3125-24 thd x 1.594 in. long (main crankcase to nose section)	3	10	1
48393	Sump Assembly Complete — Oil (for all engines except B4)	7	28	1
*48388	Sump Casting Assembly — Oil (for all engines except B4)		28	1
*48392	Sump Machining Assembly — Oil (for all engines except B4)		28	1
81185	Sump & Strainer Assembly Complete — Oil (for all engines except B4)		28	1
40356	Support — Crankshaft oil pressure pipe rear (contained in Part No. 42087 crankshaft assembly)	4	14	1
74026	Support — Inter ear deflector tube		22	9
46254	Support — Swivel fitting (for all engines except B4)	10	39	2

T

11120	Tabwasher — .719 ID x .938 OD x .058 in. thick (crankshaft oil pressure pipe rear nut; contained in Part No. 42087 crankshaft assembly)	4	14	1
17088	Tabwasher — 1.203 ID x 1.438 OD x .058 in. thick (generator drive; for use with Part No. 120645 housing assembly; for AN-1, -3, -14B & B5 only)		45	1
53723	Tag — Breather opening warning		50	1
49710	Tag — Fuel warning		58	1
55753	Tag — Notice — To outside of pliofilm bag		50	1
7766	Tag — Oil slushed carburetor warning		58	1
45943	Tappet Assembly — Valve	2	6	18
*39492	Tappet — Valve		6	18
59739	Tee — Pipe hose — Cylinder head oil drain No. 7 & 8 (for B4 only)		39	1
*88135	Terminal Assembly — Thermocouple wire lock type		21	1
*88136	Terminal — Thermocouple wire		22	1
*88136	Terminal — Thermocouple wire		22	1
101248	Thermocouple Assembly	5	21	1
103106	Thermocouple Assembly Complete — Sparkplug gasket type (optional equipment)		21	1
99953	Tube — .253-.273 ID x 14.875-15.125 in. long (5 m/m ignition cable protecting inside magneto conduit; detail of assembly No. 90461)		54	9
99953	Tube — .253-.273 ID x 14.875-15.125 in. long (5 m/m ignition cable protecting inside magneto conduit; detail of assembly No. 90456)		55	9
109461	Tube Assembly — Propeller shaft thrust bearing oil transfer (for B4 only)		5	1
†121202	Tube — Collector case to rear case oil drain (replaces No. 86890; for use with Part No. 126310 collector case)		31	1
†121203	Tube — Collector case to rear case oil drain (replaces No. 86826; for use with Part No. 126310 collector case)		31	1
40357	Tube — Crankshaft oil pressure (contained in Part No. 42087 crankshaft assembly)	4	14	2
74014	Tube — Inter ear deflector blast		22	9
8846	Tube — Internal breather (for all engines except B4)		30	2
†4807	Tube — Rear to collector case oil pressure	9	40	1
2075	Tube — Tachometer drive oil		36	2
2146	Tube — Tachometer drive oil plug right hand (for B4 only)		45	1
27358	Tubing Assembly — Carburetor to primer distributor (for B4 & B5 only)		58	1
27357	Tubing — Carburetor to primer distributor (for B4 & B5 only)		58	1
26508	Tubing Complete — Cylinder No. 9 primer	12	50	1

Section III
Alphabetical Parts List

Pratt & Whitney Aircraft
Parts Catalog

Part Number	Nomenclature	Figure Number	Page Number	Total Units Assy.
27205	Tubing Complete — Cylinder No. 1 primer	12	50	1
27206	Tubing Complete — Cylinder No. 2 primer	12	50	1
27207	Tubing Complete — Cylinder No. 3 primer	12	50	1
27208	Tubing Complete — Cylinder No. 8 primer	12	50	1
V				
40111	Valve Assembly Complete — Propeller regulator (for AN engines only)		6	1
71166	Valve — Exhaust (<i>supersedes No. 14043</i>)	5	19	9
3485	Valve — Intake	5	19	9
22895	Valve — Oil return check	9	43	1
25978	Valve & Sear Assembly — Oil return check		43	1
21355	Valvelock — Exhaust	5	19	18
W				
179	Washer — $\frac{3}{32}$ ID x $\frac{1}{4}$ OD x $\frac{1}{32}$ in. thick (plate data)		8	4
35432	Washer — .126 ID x $\frac{1}{4}$ OD x .025 in. thick (deflector)		25	4
11050	Washer — $\frac{25}{64}$ ID x $\frac{13}{16}$ OD x .172 in. thick (magneto coupling flange)	14	56	2
10762	Washer — .658 ID x $\frac{13}{16}$ OD x $\frac{9}{16}$ in. thick (intake valve spring upper)	5	19	9
8760	Washer — .883 ID x 1 OD x $\frac{9}{16}$ in. thick (exhaust valve spring upper)	5	19	9
50341	Washer — 1.173 ID x 1.692 OD x .420 in. thick (valve spring lower; <i>supersedes No. 8759</i>)	5	19	18
39576	Washer — Crankshaft front plug (for AN-14B, B3 & B5 only; contained in Part No. 39892 crankshaft assembly)	4	14	1
47705	Washer — Crankshaft front plug (for AN-14B, B3 & B5 only; contained in Part No. 42087 crankshaft assembly)	4	14	1
MS 122030	Washer-Lock, spring .194-.205 ID x .337 OD x .047-.053 in. thick (magneto shields attaching screw nuts; <i>supersedes No. 726</i>)	14	56	4
1093	Washer — Magneto shaft packing (for use with magnetos not having lip type oil seal)		47	2
12228	Washer — Plain $\frac{11}{64}$ ID x $\frac{5}{16}$ OD x $\frac{1}{32}$ in. thick (crankshaft front plug; for AN-14B, B3 & B5 only)		14	3
4220	Washer — Plain $\frac{13}{64}$ ID x $\frac{3}{8}$ OD x $\frac{3}{64}$ in. thick (primer distributor to cylinder No. 1 intake pipe screws; <i>supersedes No. 11751</i>)	12	50	2
171	Washer — Plain $\frac{17}{64}$ ID x $\frac{1}{2}$ OD x $\frac{1}{16}$ in. thick (connection breather exhaust screw; for B4 only)		6	1
171	Washer — Plain $\frac{17}{64}$ ID x $\frac{1}{2}$ OD x $\frac{1}{16}$ in. thick (oil feed bracket)		11	2
171	Washer — Plain $\frac{17}{64}$ ID x $\frac{1}{2}$ OD x $\frac{1}{16}$ in. thick (breather connection screw; for all engines except B4)	8	35	1
171	Washer — Plain $\frac{17}{64}$ ID x $\frac{1}{2}$ OD x $\frac{1}{16}$ in. thick (carburetor ell cover screws; for B3, B4 & B5 only)	10	40	3
171	Washer — Plain $\frac{17}{64}$ ID x $\frac{1}{2}$ OD x $\frac{1}{16}$ in. thick (tackometer coupling)	9	45	4
171	Washer — Plain $\frac{17}{64}$ ID x $\frac{1}{2}$ OD x $\frac{1}{16}$ in. thick (gun drive cover; for AN engines only)		46	4
171	Washer — Plain $\frac{17}{64}$ ID x $\frac{1}{2}$ OD x $\frac{1}{16}$ in. thick (magneto drive cover)	10	47	8
171	Washer — Plain $\frac{17}{64}$ ID x $\frac{1}{2}$ OD x $\frac{1}{16}$ in. thick (vacuum pump drive cover; use (4) units with plain studs)		47	8
171	Washer — Plain $\frac{17}{64}$ ID x $\frac{1}{2}$ OD x $\frac{1}{16}$ in. thick (gun synchronizer)	11	48	4
722	Washer — Plain $\frac{17}{64}$ ID x $\frac{25}{32}$ OD x $\frac{1}{16}$ in. thick (gun synchronizer)	11	48	1
12376	Washer — Plain $\frac{17}{64}$ ID x $\frac{5}{8}$ OD x $\frac{1}{16}$ in. thick (use (8) units for all engines except B4 — for use with Part No. 39997 bolt & wing nut assembly; on B4 use extra unit on Part No. 5610 wing nut)	6	28	9
12156	Washer — Plain $\frac{17}{64}$ ID x $\frac{15}{32}$ OD x $\frac{1}{32}$ in. thick (propeller regulator valve cover; for all engines except B4)	2	6	4
29593	Washer — Plain .311 ID x .459 OD x $\frac{3}{32}$ in. thick (sparkplug conduit)		52	9
29593	Washer — Plain .311 ID x .459 OD x $\frac{3}{32}$ in. thick (sparkplug conduit)		54	7
29593	Washer — Plain .311 ID x .459 OD x $\frac{3}{32}$ in. thick (sparkplug conduit)		55	1
29593	Washer — Plain .311 ID x .459 OD x $\frac{3}{32}$ in. thick (sparkplug conduit)		55	1
172	Washer — Plain $\frac{21}{64}$ ID x $\frac{9}{16}$ OD x $\frac{1}{16}$ in. thick (nose section to Part No. 42422 main crankcase stud)	2	8	1

Part Number	Nomenclature	Figure Number	Page Number	Total Units Assy.
172	Washer — Plain $2\frac{1}{64}$ ID x $\frac{9}{16}$ OD x $\frac{1}{16}$ in. thick (main crankcase to nose housing long stud)	2	8	1
172	Washer — Plain $2\frac{1}{64}$ ID x $\frac{9}{16}$ OD x $\frac{1}{16}$ in. thick (oil sump attaching studs)	7	30	4
172	Washer — Plain $2\frac{1}{64}$ ID x $\frac{9}{16}$ OD x $\frac{1}{16}$ in. thick (collector to main crankcase)		35	1
172	Washer — Plain $2\frac{1}{64}$ ID $\frac{9}{16}$ OD x $\frac{1}{16}$ in. thick (intake pipe studs & bolt)		35	27
172	Washer — Plain $2\frac{1}{64}$ ID x $\frac{9}{16}$ OD x $\frac{1}{16}$ in. thick (oil pump)		43	6
172	Washer — Plain $2\frac{1}{64}$ ID x $\frac{9}{16}$ OD x $\frac{1}{16}$ in. thick (generator drive cover)	9	45	4
172	Washer — Plain $2\frac{1}{64}$ ID x $\frac{9}{16}$ OD x $\frac{1}{16}$ in. thick (fuel pump drive bracket)	10	48	4
172	Washer — Plain $2\frac{1}{64}$ ID x $\frac{9}{16}$ OD x $\frac{1}{16}$ in. thick (fuel pump drive cover)	10	48	4
172	Washer — Plain $2\frac{1}{64}$ ID x $\frac{9}{16}$ OD x $\frac{1}{16}$ in. thick (carburetor adapter nuts; for engines using NA-R9B carburetors; use (4) units for engines using NA-R9C2 carburetors)	15	57	6
172	Washer — Plain $2\frac{1}{64}$ ID x $\frac{9}{16}$ OD x $\frac{1}{16}$ in. thick (carburetor air screen nuts; for engines using NA-R9B carburetors with $\frac{3}{16}$ -24 thd studs in the intake flange)	15	58	4
172	Washer — Plain $2\frac{1}{64}$ ID x $\frac{9}{16}$ OD x $\frac{1}{16}$ in. thick (carburetor bracket nuts; for NA-R9C2 carburetors)	15	58	4
12094	Washer — Plain $2\frac{1}{64}$ ID x $1\frac{1}{16}$ OD x $\frac{3}{32}$ in. thick (rocker oil drain fitting; supersedes No. 176; for all engines except B4)	7	30	2
12094	Washer — Plain $2\frac{1}{64}$ ID x $1\frac{1}{16}$ OD x $\frac{3}{32}$ in. thick (rear case to collector)		40	16
17331	Washer — Plain $2\frac{1}{64}$ ID x $\frac{9}{16}$ OD x $\frac{1}{8}$ in. thick (oil sump rear attaching studs; for all engines except B4)	7	30	2
173	Washer — Plain $2\frac{5}{64}$ ID x $1\frac{1}{16}$ OD x $\frac{1}{16}$ in. thick (nose section to main crankcase studs)	2	8	17
173	Washer — Plain $2\frac{5}{64}$ ID x $\frac{1}{16}$ OD x $\frac{1}{16}$ in. thick (propeller thrust cover nuts)	2	8	7
173	Washer — Plain $2\frac{5}{64}$ ID x $1\frac{1}{16}$ OD x $\frac{1}{16}$ in. thick (collector to main crankcase)		35	17
173	Washer — Plain $2\frac{5}{64}$ ID x $1\frac{1}{16}$ OD x $\frac{1}{16}$ in. thick (accessory pad cover)	9	44	6
173	Washer — Plain $2\frac{5}{64}$ ID x $1\frac{1}{16}$ OD x $\frac{1}{16}$ in. thick (magneto mounting)		56	6
173	Washer — Plain $2\frac{5}{64}$ ID x $1\frac{1}{16}$ OD x $\frac{1}{16}$ in. thick (carburetor nuts)	15	58	4
9876	Washer — Plain $2\frac{5}{64}$ ID x $\frac{3}{4}$ OD x $\frac{3}{32}$ in. thick (gun drive; use (1) unit for AN-4, -6, -6B, -10, -12, -12B & -14B)	10	46	2
25781	Washer — Plain $2\frac{5}{64}$ ID x $\frac{5}{8}$ OD x $\frac{3}{32}$ in. thick (gun drive right hand; for all engines except AN-1, -3, B3, B4 & B5)	10	46	1
186	Washer — Plain $2\frac{9}{64}$ ID x $\frac{7}{8}$ OD x $\frac{3}{32}$ in. thick (main crankcase bolts; use (12) units for B4)	3	11	14
186	Washer — Plain $2\frac{9}{64}$ ID x $\frac{7}{8}$ OD x $\frac{3}{32}$ in. thick (valve rocker shaft)	5	20	18
9383	Washer — Plain $2\frac{9}{64}$ ID x $1\frac{1}{16}$ OD x $\frac{1}{4}$ in. thick (blower spring drive bolt nut)	4	15	1
720	Washer — Plain $1\frac{5}{32}$ ID x $\frac{7}{8}$ OD x $\frac{1}{16}$ in. thick (engine mount bolt)		35	8
9401	Washer — Plain .4531 ID x .802 OD x .093 in. thick (main crankcase stud)	3	11	1
104749	Washer — Plain .516 ID x 1.188 OD x .125 in. thick (starter shaft; supersedes No. 184)	9	44	1
40358	Washer — Plain $1\frac{5}{64}$ ID x $1\frac{1}{8}$ OD x $\frac{1}{16}$ in. thick (crankshaft oil pressure pipe rear nut; contained in Part No. 42087 crankshaft assembly)	4	14	1
70489	Washer — Plain .781 ID x 1.00 OD x .031 in. thick (gun synchronizer)	11	48	1
Y				
39998	Yoke — Inter cylinder deflector		28	8

**SECTION IV
NUMERICAL INDEX**

Part Number	Figure Number	Page Number	Total Units Assy.	Part Number	Figure Number	Page Number	Total Units Assy.
2		34	1	171	10	46	4
3	10	47	2		10	46	8
6	15	57	2		10	47	8
10	9	45	1		11	48	4
†15		10	1	172	2	8	1
		33	2		2	8	1
24	8	31	1		7	30	4
25		36	2			35	1
†27		10	8			35	27
28		36	2			43	6
30	8	34	1		9	45	4
	8	34	1		10	48	4
44	2	6	1		10	48	4
46		14	1		15	57	6
62	2	5	1		15	58	4
		36	1		15	58	4
63	4	15	1	173	2	8	17
	4	17	8		2	8	7
69	11	48	1			35	17
70	11	48	2		9	44	6
†85	10	46	2			56	6
.87 Superseded by 224883					15	58	4
93		17	1	179		8	4
104 Optional to 288900				186	3	11	14
104 Optional to 359231					5	20	18
109 Optional to 288901				202	3	10	2
109 Optional to 359232					3	11	2
117 Optional to 288902					8	33	8
122 Optional to 288904					8	34	8
122 Optional to 359233					8	34	2
129		36	2		9	44	4
131		40	1		9	45	4
		43	1		10	47	8
		43	1	208	11	48	2
132		43	2	215	7	28	4
134		20	10	220	4	14	3
136		36	3		11	48	2
138		36	1	232	10	43	1
		38	1	233	2	6	1
143		28	1	234		40	1
149	10	41	1		10	43	1
153		47	12		10	43	1
156		8	4		10	43	1
167		12	3	235	9	43	1
171		6	1	237		28	2
		11	2	242	11	48	1
	8	35	1	245	14	56	4
	10	40	3	255	8	35	2
	9	45	4	257	9	46	2

Section IV
Numerical Parts List

Parts Catalog

Part Number	Figure Number	Page Number	Total Units Assy.	Part Number	Figure Number	Page Number	Total Units Assy.
<i>282 Superseded by AN 115808</i>				†1171		36	2
285	11	48	4	†1172	8	33	2
299	4	14	4	†1174	9	40	2
326	4	17	8	1175	10	47	2
463	3	11	4	1177		45	1
464	3	11	6	1187	9	35	1
<i>501 Superseded by AN 121502</i>				1189	9	45	1
502		11	2	†1191	9	39	1
	10	41	4	1314	10	46	2
	11	48	1	1325	7	30	1
511	2	8	1	1326	8	34	1
<i>511 Superseded by AN 121553</i>				1335	8,9	44	1
512		35	1	1345	3	11	1
513		35	27		8	34	1
519		43	1	1427	10	43	1
520	14	56	4	1428	10	41	1
523	10	46	2	1482	10	47	2
528		8	2	†1578	3	12	1
532	5	20	18	*1579		41	1
533	3	11	8	1741	9	45	1
	4	15	1	1742	9	44	1
534		35	8	1744	9	44	1
542	9	44	1	1778	8	33	1
<i>625 Superseded by 89102</i>				1921	11	48	1
†625+4	5	19	45	*1943		11	1
†626+4	10	38	2	1989		30	2
†656+4	10	38	4	2032	11	48	1
†658+4		38	2	2075		36	2
713		12	1	†2108	5	17	18
720		35	8	2146		45	1
722	11	48	1	2147		45	1
<i>726 Superseded by MS 122030</i>				2211	9	45	2
729		25	1	2383		47	2
743	4	14	1	2603	5	19	9
744	9	45	2	2604	5	19	9
	11	48	1	*2627		45	2
747		12	3	2628	10	46	1
749		12	2	2630	10	46	2
809	10	46	2	2631	11	48	1
818		8	1	2634	11	48	1
		35	1	2636	11	48	1
		35	27	2651	11	48	1
		40	1	2715	10	45	2
820	9	45	2	†2943	5	17	18
827	7	30	2	*2987		11	1
		39	1	†3033	3	11	1
861	8	35	9	3036	3	11	1
863	8	35	9	3277		44	1
981	10	46	2	3278	8	44	1
1012	3	11	1	*3447		11	1
1019	2	8	1	*3469		17	8
1020	2	8	1	3485	5	19	9
1044	2	6	18	†3496	5	17	18
1093		47	2	†3500	5	17	9
1108	10	46	2	3503	8	35	18
1139	10	43	1	3506	8	35	9
1149	7	30	1	*3508		8	1
1154	9	45	1	†3529	5	17	9
				3555	10	46	2

Parts Catalog

Section IV
Numerical Parts List

Part Number	Figure Number	Page Number	Total Units Assy.	Part Number	Figure Number	Page Number	Total Units Assy.
†3559	3	10	1	7073	4	14	1
3561	3	11	4	7359	9	38	7
3592	4	17	8	7499	9	44	1
3627	7	30	1	<i>7577 Superseded by AN 122705</i>			
3649	9	36	1	*7590		11	1
3708	13	54	9	7635	5	21	90
	13	55	9			35	17
3773		35	9	7644		33	2
3900		10	1	7766		58	1
4199	8	30	1	7916		11	2
4220	12	50	2		11	48	1
4229		31	1	7920	5	22	1
4381	2	8	6		14	56	2
		35	17	7921	14	56	2
4447	3	11	1	†7959+4		31	3
4486	3	11	6	<i>8138 Superseded by 314047</i>			
4614	8	34	79	8232	2	6	1
4669		35	9	8288	11	48	1
†4807	9	40	1	8650	12	50	10
5017	8	34	1	*8710		33	1
5018	8	34	1	†8711	8	34	1
	8	34	1	8712	8	33	1
5019	8	34	1	8734	10	41	1
*5021		34	1	8735	10	41	1
5023		34	1	8756		56	6
5025	8	31	1	8760	5	19	9
5032	8	33	1	8797	8	34	1
5033	8	33	1	8812	3	11	6
5198	11	48	1	8846		30	2
5199	11	48	1	8955	5	20	18
5204	10	46	1	<i>9016 Optional to 288906</i>			
*5205		46	1	<i>9016 Optional to 359234</i>			
†5206+4	10	38	4	9035	8	34	1
5453	8	34	1	†9036	8	33	1
5484		56	2	9049	10	43	1
5484-1	14	56	2	†9085+4		31	1
5484-2	14	56	2			39	4
5509	12	50	5	†9252+4		31	2
5610		28	3	†9264	5	19	18
5658	3	11	2	9265	5	21	36
†5670	3	10	1	†9269	3	10	1
5709	10	46	2	*9293		18	9
	10	46	1			18	9
<i>5832 Superseded by 126833</i>				9294	5	19	18
5999	2	6	18	9317	3	11	35
6091	10	43	1	9383	4	15	1
6191		35	1	†9385+4		31	1
	8	40	2	9401	3	11	1
†6237	3	11	2	9405	4	14	1
6262	10	40	1	9423	4	14	1
6263	10	40	3	9514	5	18	9
6277	15	58	4		5	18	9
6514	8	34	1	9598	8	40	1
6515	8	33	1	9632	10	47	1
6558	7	30	2	9633		47	1
6906	15	58	1	9667	2	6	1
6924		43	1		2	6	1
7072	4	15	1	9876	10	46	2
				9903	3	11	1

Section IV
Numerical Parts List

Parts Catalog

Part Number	Figure Number	Page Number	Total Units Assy.
10110	10	41	1
<i>10128 Superseded by 224884</i>			
10185	10	46	2
10262		12	1
		14	1
10266		3	11
10268	3	11	1
10269	3	11	1
10270	2	6	1
10395	13	56	1
*10413		57	1
10414	8	33	2
10464		35	9
10486	5	19	9
10502		46	2
10524	9	43	1
10538		46	2
10545	9	46	2
†10682	10	36	1
	10	39	2
10762	5	19	9
10897		36	1
10941	11	48	1
10942	5	21	18
11042		43	1
11045		43	1
11048	14	56	2
11049	10	47	2
11050	14	56	2
†11051	9, 10	36	4
11052	14	56	2
11106	4	14	1
11120	4	14	1
†11345+4		31	4
	10	38	4
11357	8	33	1
11359		44	
11468		47	2
11473	5	21	36
*11475		19	9
*11476		19	9
†11477	5	19	9
	5	19	9
11521		31	2
	10	36	9
11590	9	45	1
11598	15	57	1
11747	12	50	2
		56	1
11748		35	1
		52	1
		54	1
12009		8	1
		40	1
12012		22	7
		24	1
		24	1
		25	1
		26	2

Part Number	Figure Number	Page Number	Total Units Assy.
12012		26	1
		26	1
		27	1
		27	1
12046	15	58	2
†12054+4	5	19	18
		31	2
†12055+4	2	5	2
†12057+4	3	10	17
12079		52	1
		52	1
†12081+4	3	10	90
†12082+4	9	38	2
†12085+4	3	10	1
†12086+4	9	39	4
†12088+4	2	5	2
†12089+4	2	5	2
†12091+4	9	38	4
	15	57	4
12094	7	30	2
		40	16
12156	2	6	4
12228		14	3
†12317+4	7	30	4
	10	38	6
	10	41	2
	10	41	2
12376	6	28	9
12398		43	2
12574	10	46	2
12677	4	15	14
12678	4	15	7
<i>12768 Optional to 288910</i>			
<i>12768 Optional to 359236</i>			
<i>12769 Superseded by 357281</i>			
12788	8	34	1
12856	2	6	4
	5	21	72
	10	46	8
	10	47	4
	13	56	4
12857	4	14	1
12874	9	44	1
12973	5	19	9
12974	5	19	9
13028		45	1
13089	14	56	1
13090	14	56	1
13404		43	1
13621	5	19	18
*13645		10	1
13651	8	30	1
13652		10	1
13700		6	1
<i>13705 Super eded by 265149</i>			
*13715		8	1
13755	8	34	1
*13841		34	1
13842	8	34	1

Section IV
Numerical Parts List

Parts Catalog

Part Number	Figure Number	Page Number	Total Units Assy.
14013	6	22	7
	6	24	1
	6	24	1
	6	25	1
	6	26	2
	6	26	1
	6	26	1
	6	27	1
	6	27	1
	6	27	1
14096	5	21	36
14126	13	54	1
14128	13	54	1
	13	55	1
14319		56	1
		56	1
14320		56	2
		56	3
14321		56	1
14322		56	1
*14356		45	1
14357	9	45	2
14438	5	21	9
		33	1
14537	9	45	2
14538	<i>Optional to 287778</i>		
14548	9	45	4
*14604		45	1
14667	7	30	2
14827	15	58	2
14828	15	58	1
15008	2	6	1
†15072+4	5	19	72
*†15443	2	8	4
		40	2
15893	13	54	9
	13	55	9
15937	5	19	18
15950	4	15	1
16028	2	8	7
16047	9	45	2
16405	5	20	18
16475	3	8	1
16487	15	57	1
16512	10	46	1
16532	10	47	1
17009	10	41	1
17018	5	19	18
17038		46	2
		46	1
17088		45	1
17089		45	1
17090		44	1
17091		45	1
17331	7	30	2
17346		20	9
		21	4
	8	31	3
	8	35	1

Part Number	Figure Number	Page Number	Total Units Assy.
17346		36	5
	12	50	4
17574	10	43	1
*18016		11	1
18169		8	4
18599	3	11	1
18600		11	1
18746		45	1
19149	2	6	1
19209	2	6	1
19559		34	1
19575	8	35	1
†19649		31	1
19727		56	1
19865		28	1
	10	36	1
	10	36	1
	10	39	2
†19868+4	10	38	4
19875	4	14	1
†20117		28	2
20126	7	28	2
20159	2	6	1
20228	12	50	2
20229	12	50	5
20251		28	1
20416	<i>Optional to 357276</i>		
20545	4	15	1
	5	20	18
20546		14	1
	5	20	18
†20786	5	17	9
21027		20	9
21099	<i>Superseded by 77908</i>		
21355	5	19	18
21896	8	30	1
22374	4	12	1
22895	9	43	1
22896	9	43	1
22897	9	43	1
23000	12	50	2
23256	7	30	1
†23299+4	10	38	2
23435	9	43	1
23612		22	7
		24	1
		24	1
		25	1
		26	2
		26	1
		26	1
		27	1
		27	1
*23834		12	1
23902	4	12	2
23904	4	12	1
23922		12	1
23930	12	50	2
24040		44	1

Section IV
Numerical Parts List

Parts Catalog

Part Number	Figure Number	Page Number	Total Units Assy.
24116		48	1
24117		48	1
24230		43	2
24437	14	56	1
24883		22	7
		24	1
		24	1
		25	1
		26	2
		26	1
		26	1
		27	1
		27	1
		27	1
24884	6	22	14
	6	24	2
	6	24	2
	6	25	2
	6	26	4
	6	26	2
	6	26	2
	6	27	2
	6	27	2
	6	27	2
24929		36	2
25049		35	8
25050		35	8
25781	10	46	1
25820		40	1
25821		40	1
25893	5	22	18
25978		43	1
†26264+4	9	39	4
26432	2	8	17
	2	8	7
	9	44	6
	15	58	4
26508	12	50	1
†27056	5	20	7
27205	12	50	1
27206	12	50	1
27207	12	50	1
27208	12	50	1
27210	12	50	1
27357		58	1
27358		58	1
27953	14	56	2
27961		56	2
27962		56	2
28160	5	19	9
28161	5	19	9
†28255+4		5	4
28834		36	1
28853	14	56	1
28955		40	1
29355		55	1
		55	1
29407		52	9
		54	7

Part Number	Figure Number	Page Number	Total Units Assy.
29407		55	1
		55	1
29410	5	19	9
29593		52	9
		54	7
		55	1
		55	1
29783		52	9
		55	9
29893		52	9
		54	7
		55	1
		55	1
29894		52	54 in.
		54	42 in.
		55	8 in.
		55	12 in.
29941		52	9
		54	7
30489	5	20	18
30604	8	34	1
31123		44	1
31346	10	48	1
31724	5	20	18
*31740		21	9
32370 Superseded by 231623			
32383		52	9
		54	9
†32735	5	21	36
32835 Optional to 288914			
32835 Optional to 359238			
†32983	4	15	1
33241		55	1
33267	15	58	1
33268	15	58	1
33415		8	2
	6	28	18
	7	30	2
	7	30	4
	7	30	4
	7	30	4
		35	2
		35	18
		39	2
		40	4
		40	15
		43	5
		43	4
		43	2
	9	45	4
	10	48	4
	10	48	4
	15	57	4
	15	58	4
	15	58	4
†33455	3	11	2
33688	13	50	1
33690	13	54	1
33694		52	1

Parts Catalog

Section IV
Numerical Parts List

Part Number	Figure Number	Page Number	Total Units Assy.
33695		55	1
33784	2	6	18
33858		43	2
33891	3	11	1
	8	35	2
34079	5	21	16
	7	30	4
		39	3
34094		58	1
34347	2	8	1
34461	4	12	2
34462	4	12	1
34463	4	12	1
34464	4	12	1
34465	4	12	1
*34466		12	1
*34467		12	1
34585		55	1
34587		52	9
34588		54	7
34637		47	1
34749		34	1
35012		56	1
35013		56	1
35081	8	34	1
35091	<i>Superseded by 231627</i>		
*35138		47	1
35139	10	47	1
35140	10	47	1
35169	10	47	1
35431		25	2
35432		25	4
35438		25	4
35439		24	42
		24	2
		25	2
		25	6
		25	2
		26	12
		26	6
		26	6
		27	6
		27	6
		27	6
35517	10	47	1
35721		8	1
†35807+4		58	1
†35809+4		58	1
†35810+4		58	1
35815		57	1
35848	13	54	1
35849	13	54	1
	13	56	1
35850	13	54	1
	13	55	1
35851	13	54	1
35930	8	35	1
35932		6	1
	8	35	1

Part Number	Figure Number	Page Number	Total Units Assy.
35961	10	48	1
36054	13	56	4
36090		33	2
		40	2
36553	4	12	1
37091		57	1
37100		8	1
37123	<i>Superseded by 231628</i>		
37141	<i>Superseded by 123790</i>		
37319	<i>Superseded by 288045</i>		
37907		47	1
37965	2	8	1
†37966	2	5	1
38093	<i>Superseded by 395296</i>		
38109	5	20	9
†38300+4	3	10	6
38353		6	1
	8	35	1
38354		35	1
38355		35	1
*38360		41	1
*38361		41	1
*38362		41	1
38363	10	41	1
38364	10	41	1
38366		41	1
38367		41	1
38368	10	41	4
38436		35	1
38602		33	8
38606	2	8	1
	8	35	1
38674		52	9
		55	9
38987		28	1
†39079+4	7	28	2
*39106		36	1
39133	11	48	1
39171	11	48	1
*39287		21	18
39288	5	21	18
39292	<i>Superseded by 282992</i>		
39304	2	6	1
39314	5	21	8
39377	13	50	1
	13	54	1
*39485		5	1
39487	2	5	1
39489	2	6	1
39490	2	6	9
39491	2	6	9
*39492		6	18
†39493	2	5	9
†39494	2	6	4
†39495	2	6	9
†39496	2	6	4
†39523	5	17	9
39526	5	21	8
39527	5	21	9

Numerical Parts List

Parts Catalog

Part Number	Figure Number	Page Number	Total Units Assy.
39528	5	21	9
39570	4	12	1
39571		12	1
39574	4	14	1
39575	4	14	1
39576	4	14	1
39577	4	14	1
39578	4	14	1
39579	4	14	1
39580	4	14	1
39581	<i>Superseded by 261279</i>		
*39623		17	9
39649		54	1
39650		50	1
39697	15	58	1
39710		8	18
*39737		15	1
39748	4	17	8
39749		17	1
*39782		16	1
39783	4	17	4
†39785A	4	16	8
†39786	4	15	1
†39787		15	1
39788		15	1
39892	<i>Superseded by 261280</i>		
39910	15	58	2
*39915		12	1
*39979		22	9
39980	6	22	9
*39981		22	7
39982	6	22	7
*39985		26	2
39986	6	26	2
*39987		24	1
39988	6	24	1
*39989		27	1
39990	6	27	1
*39991		26	1
39992	6	26	1
39993		22	9
39997	6	28	8
39998		28	8
39999		28	8
40000	6	28	8
40049	5	21	1
40050	5	21	1
*40052		18	18
40111		6	1
†40180+4		38	1
40352	4	14	1
40353	4	14	1
40356	4	14	1
40357	4	14	2
40358	4	14	1
40382	7	30	1
40383		35	1
*40588		27	1
40589		27	1

Part Number	Figure Number	Page Number	Total Units Assy.
*40592		26	1
40593		26	1
†40698	5	20	2
41461		22	1
*41462		24	1
41463	6	24	1
41514		36	1
†42419+4	2	5	7
†42422+4	3	10	1
43272	10	43	1
43340		58	1
43567		45	1
43568		31	1
†43613		38	8
43982		46	8
44075	<i>Superseded by 264399</i>		
44076	4	14	1
		33	1
		40	1
†44078	4	12	1
44107		40	3
44718	4	12	2
44932		28	1
45173		31	1
†45335	5	20	18
45936		50	1
45937	<i>Superseded by 15937</i>		
45941	7	30	1
45942		21	18
45943	2	6	18
46232	10	47	1
*46233		48	1
46234	10	48	1
46253	10	39	2
46254	10	39	2
46255	10	39	2
46256		39	2
46553	<i>Superseded by 261278</i>		
46816		34	1
47131		50	1
47132		54	1
47266		54	9
		55	9
*47517		17	9
47518	5	17	9
47705	4	14	1
47913	8	33	1
48130	10	39	2
*48368		28	1
48389	7	30	1
48390	7	30	1
*48392		28	1
48393	7	28	1
48564		36	1
48565		36	1
48601	15	58	2
48610		22	1
48776	12	50	10

Parts Catalog

Section IV
Numerical Parts List

Part Number	Figure Number	Page Number	Total Units Assy.
49353		25	2
49402		25	1
49403	6	25	1
49404		25	1
49405		25	1
49406	6	25	1
49407	6	25	1
49710		58	1
49847	15	58	2
50341	5	19	18
50681	9	45	1
51099	7	30	1
53723		50	1
54363		52	9
		55	9
54364	13	52	9
	13	55	9
†54610+4	3	10	11
54612		20	18
55753		50	1
56433		22	18
57169	2	6	1
57686		58	1
57852		36	1
57945		22	18
		24	28
		24	4
		24	4
		25	2
		25	4
		26	8
		26	4
		26	4
		27	4
		27	4
57945 Superseded by 139479			
*57999		36	1
58321		24	6
		26	6
58322		22	27
		24	56
		24	6
		24	6
		25	8
		25	8
		26	16
		26	8
		26	8
		27	8
		27	8
		28	3
		28	48
58322 Superseded by 126832			
58323		24	14
		24	4
		24	4
		25	2

Part Number	Figure Number	Page Number	Total Units Assy.
58323		26	4
		25	2
		26	2
		26	2
		27	2
		27	2
58325		22	18
58328		22	45
58328 Superseded by 143575			
58329		22	18
58332		24	4
		24	4
58404		25	20
†58843+4		5	2
59189	9	43	1
59477 Optional to 304911			
59482		52	9
		55	9
59739		39	1
70472	8	35	9
70489	11	48	1
71139 Optional to 325682			
71145		25	1
71147		25	1
71148		24	1
		25	1
71149		25	1
71166	5	19	9
71538		24	1
72430		35	9
73981		24	7
		26	2
		25	1
		26	1
		26	1
		27	1
		27	1
73984		26	1
73988		22	7
		24	1
		24	1
		25	1
		26	2
		26	1
		26	1
		27	1
		27	1
73989		24	1
		24	1
73990		27	1
73991		28	1
73995		22	18
73996		22	9
74012		22	7
		26	2
		26	1
		26	1

Numerical Parts List

Parts Catalog

Part Number	Figure Number	Page Number	Total Units Assy.	Part Number	Figure Number	Page Number	Total Units Assy.
74012		27	1	*80487		34	1
		27	1	80489		34	1
		27	1	80490		34	1
74013		22	7	*80492		33	1
		24	1	80493		33	1
		24	1	*80494		34	1
		25	1	*80495		36	1
		26	2	*80804		8	1
		26	1	*80805		8	1
		26	1	80806		8	1
		27	1	80983		6	1
		27	1	80984		6	1
74014		20	9	80985 <i>Superseded by 10262</i>			
74015		24	1	80986 <i>Superseded by 261281</i>			
74016		22	7	81058		34	1
		25	1	81170		34	1
		26	2	81185		28	1
		26	1	81186		11	1
		26	1	81188		11	1
		27	1	81189		11	1
		27	1	82307	13	52	9
		27	1		13	55	9
74017		25	1	82515		24	1
74018		25	1	82516		24	1
74026		22	9	82517		24	1
74088		27	1	83323		11	9
*74927		57	1	84106		43	2
74929		30	1	84251	4	15	1
74932		30	1		4	17	8
*74943		10	1	84462		50	1
74945		8	1	84463		54	1
74947		57	1	84623		43	1
74955		8	1	86266	10	41	1
74956		39	1	87241		33	1
74957		39	1	*88135		21	1
74963		39	1	*88136		22	1
75162		35	1			22	1
76284		25	1	*88708		52	2
76328		25	1	†89102		31	9
*76329		25	1	89746	7	30	1
76330		25	1	†90105+4		31	2
*76331		25	1	†90106+4		5	2
76365		45	1	90437	13	52	1
76366		45	1	90440	13	55	1
76367		45	2	90560	5	21	18
76369		22	1	91291		57	1
76785		25	4	91292		58	1
77323		15	1	91293		58	1
77761		6	1	91316		57	1
†77765+4		5	2	91317		57	1
77766		6	1	91318		57	1
77908 <i>Superseded by AS 100004</i>				91341	2	6	1
†77913+4	9, 10	38	8	91453	7	28	3
78858	9	46	12	91454	7	28	1
78928		24	1	91745	4	12	1
		24	1	92367	13	52	9
*80136		24	1	92368	13	52	18
80137		24	1		13	54	14
80328		22	9		13	54	2
80483		31	1		13	55	2
*80484		31	1	92369	13	52	18
80485		31	1		13	54	14
80486		31	1		13	55	2

Parts Catalog

Section IV
Numerical Parts List

Part Number	Figure Number	Page Number	Total Units Assy.
92369	13	55	2
92370	13	52	63 in.
	13	54	49 in.
	13	54	9 in.
	13	55	13 in.
92372	13	54	7
92373	13	54	1
92374	13	55	1
93314	6	25	2
96121		50	
		54	
96122		52	9
		55	9
96124		54	9
		55	9
96125		52	9
		55	9
96347		52	9
		54	9
97927		34	1
98996	5	22	1
98997	5	22	1
99953		54	9
		55	9
100186		50	1
101248	5	21	1
101249	5	22	1
103106		21	1
104749	9	44	1
106229		25	1
106230		25	1
106231		25	1
106232		25	1
106233		25	1
106234		25	1
109453		5	1
109454		5	1
109461		5	1
*109720		5	1
109722		5	1
110019		11	1
110514	5	21	90
113811		50	1
113812		54	1
114377		36	1
114378		36	1
115683		25	1
115684		25	1
116576	2	6	1
119525		45	1
119526		45	1
119527		44	1
119528		44	1
120645		44	1
†121202		31	1
†121203		31	1
†121207		39	1
†121208		40	2

Part Number	Figure Number	Page Number	Total Units Assy.
†121209		40	1
*121211		30	1
*121216		36	1
*121217		36	1
121839	5	21	36
†123423+4	10	39	4
†123441+4	10	47	4
123596		47	1
123724		36	1
123790	13	50	
	13	54	
126299	9, 10	36	1
126301	9, 10	36	1
126302	9, 10	36	1
126304		36	1
126307	8	30	1
126308	8	30	1
126310		30	1
126344		28	2
126741	<i>Superseded by 399353</i>		
126742	<i>Superseded by 399354</i>		
126832		27	2
126833		27	28
126834	<i>Superseded by 399355</i>		
127015		56	40 ft.
127599	5	19	18
128095		22	18
†128495		16	1
128502		15	1
128511		15	1
128512		15	1
128648		58	2
128651		58	1
134448	7	28	1
134891	9	44	1
135054		44	1
137705		22	18
139479		27	4
143575		26	6
143774		27	1
151627		22	7
		24	1
		24	1
		26	2
		25	1
		26	1
		26	1
		27	1
		27	1
*151744		24	1
151882	9, 10	36	1
156010	7	28	1
156011	7	28	1
158188	5	20	18
	5	21	16
	7	30	4
		39	1

Section IV
Numerical Parts List

Parts Catalog

Part Number	Figure Number	Page Number	Total Units Assy.
158189	5	20	18
	5	21	16
	7	30	4
		39	1
158365		22	18
164314	<i>Superseded by 383021</i>		
164315	10	46	2
164316	10	47	2
165375	13	54	1
165376	13	50	1
173007	10	43	1
*173595		27	1
*173596		27	1
175147		47	12
180799		58	1
183748	10	43	1
185956	13	52	9
	13	55	9
†188538	5	20	9
†188541	5	20	18
†188542	5	21	18
†188546	5	21	9
204446		24	35
		24	5
		24	5
		25	5
		26	10
		26	5
		26	5
		27	5
		27	5
		27	5
207098		14	1
214214		46	8
†224883	10	41	1
	10	43	1
†224884	10	41	1
*231623		52	2
		52	1
231626		50	1
		54	1
231627	13	52	1
	13	52	1
231628		52	1
		52	1
234221	5	21	9
234223	5	21	18
*256309		52	1
*261278		12	1
*261279		12	1
261280	4	12	1
261281	4	12	1
261296	<i>Superseded by 261281</i>		
264399	4	14	1
265149		24	1
		25	1
		35	1
282992	5	21	18
287778	<i>Optional to 14538</i>		
287780	10	47	1
287788	9	45	2

Part Number	Figure Number	Page Number	Total Units Assy.
287792	<i>Replaced by 30684</i>		
287792	<i>Superseded by 287780</i>		
288045	10	47	1
288900	<i>Optional to 104</i>		
288900	<i>Optional to 359231</i>		
288901	<i>Optional to 109</i>		
288901	<i>Optional to 359232</i>		
288902	<i>Optional to 117</i>		
288904	<i>Optional to 122</i>		
288904	<i>Optional to 359233</i>		
288906	<i>Optional to 9016</i>		
288906	<i>Optional to 359234</i>		
288910	<i>Optional to 12768</i>		
288910	<i>Optional to 359236</i>		
288914	<i>Optional to 32835</i>		
288914	<i>Optional to 359238</i>		
288932	8	44	1
288933	10	46	2
	11	48	2
288934	2	8	1
288936	9	44	2
288938	5	19	18
288943	8	33	1
	8	34	1
	8	34	2
288947	4	14	1
303758		22	18
304911	<i>Optional to 59477</i>		
304914		52	9
		55	9
†314047		41	1
325682	<i>Optional to 71139</i>		
325683	4	15	1
331098	3	11	1
333692	<i>Superseded by 362612</i>		
343986	5	20	18
357276	<i>Optional to 20416</i>		
357281	8	33	1
359231	<i>Optional to 104</i>		
359231	<i>Optional to 288900</i>		
359232	<i>Optional to 109</i>		
359232	<i>Optional to 288901</i>		
359233	<i>Optional to 122</i>		
359233	<i>Optional to 288904</i>		
359234	<i>Optional to 9016</i>		
359234	<i>Optional to 288906</i>		
359236	<i>Optional to 12768</i>		
359236	<i>Optional to 288910</i>		
359238	<i>Optional to 32835</i>		
359238	<i>Optional to 288914</i>		
*362612		52	22 in.
		52	22 in.
383021	10	46	2
392441		21	1
		21	1
395296		20	18
395297	5	20	18
399353		17	7
399354		17	5
399355		17	2

Parts Catalog**Section IV
Numerical Parts List**

Part Number	Figure Number	Page Number	Total Units Assy.
A-22883		56	18
A-25695		56	18
A-25696		56	18
B-25697		56	18
AN 101010	5	22	1
AN 115808	8	33	4
AN 121502	9	43	1
	10	43	1
AN 121504		35	13

Part Number	Figure Number	Page Number	Total Units Assy.
AN 121553	15	57	2
AN 122696	10	41	1
AN 122705		33	2
		33	2
AN 123867	5	20	18
AS 100004	10	48	1
AS 123788	3	11	1
AS 123791		44	1
MS 122030	14	56	4