

CHAPTER 9 — BEARINGS, SLEEVES, AND BUSHINGS

TABLE OF CONTENTS

Paragraph Number	Title	Chapter/Section Number	Page Number
BEARINGS, SLEEVES, AND BUSHINGS			
9-1	Introduction	9-00-00	3
9-2	Bearings.....	9-00-00	3
9-3	Bearings — Inspection.....	9-00-00	3
9-4	Bearings — Replacement.....	9-00-00	20
9-5	Bearing Removal	9-00-00	20
9-6	Bearing Installation — Ring Staking Method	9-00-00	22
9-7	Pregrooved Bearing Installation — Roll Staking Method ..	9-00-00	23
9-8	Bearing Installation — Roll Staking Method.....	9-00-00	27
9-9	Bearing Installation — Segment Staking Method	9-00-00	30
9-10	Pregrooved Bearing Installation — Anvil Staking Method	9-00-00	32
9-11	Protection of Staked Bearings During Inspection	9-00-00	33
9-12	Bushings	9-00-00	33
9-13	Bushings — Replacement	9-00-00	33
9-14	Rod End Bearings, Inserts, and Clevis — Replacement	9-00-00	35
9-15	Elastomeric Bearings	9-00-00	51
9-16	Elastomeric Bearings — General	9-00-00	51
9-17	Elastomeric Bearings — Inspection, Maintenance, and Repair	9-00-00	51

FIGURES

Figure Number	Title	Page Number
9-1	Bearing/Sleeve Removal and Installation Workaids	21
9-2	Ring Staking.....	24
9-3	Roll or Anvil Staking Pregrooved Bearings	25
9-4	Bearing Rotational Torque Check.....	28
9-5	Roll Staking Sleeves or Bushings	29
9-6	Segment Staking.....	31
9-7	Bushing Removal and Installation Workaids.....	34
9-8	Control Tube Assemblies with Bonded or Riveted Clevises, Inserts, or Rod End Bearings.....	37

TABLES

Table Number	Title	Page Number
9-1	Bearing Inspection and Replacement Criteria	4
9-2	Bearing Wear Limits.....	5
9-3	Staking Tool Set Application	22
9-4	Control Tube Assemblies.....	38
9-5	Bearing and Sleeve Replacement Data.....	51

BEARINGS, SLEEVES, AND BUSHINGS

9-1. INTRODUCTION

Instructions for inspection and replacement of bearings are provided in the following paragraphs. Specific data for each model of helicopter is presented in tabular form following the text.

9-2. BEARINGS

9-3. BEARINGS — INSPECTION

1. Inspect bearings for defects and replace as described herein. Inspect and replace bearings as indicated in [Table 9-1](#).

a. A pit is a small, irregular cavity in the active part of the race or rolling element that can be felt with a 0.003 inch (0.076 mm) radius scribe. A pit that can be readily felt with a 0.003 inch (0.076 mm) scribe is approximately 0.015 inch (0.38 mm) wide. Pits are usually dark in appearance. Replace ball bearings when any one pit on the action surface exceeds 0.008 inch (0.21 mm). Replace roller bearings having pits on active parts of rollers or races when any pit exceeds 0.015 (0.38 mm) inch in width or a cluster of more than three pits are in an area of 0.250 inch diameter. Pits sufficient to cause loss of more than 20% of the area of contact on bore or outside diameter surface, or pits affecting face squareness over more than 20% of the circumference are cause for replacement.

b. Dents are slight depressions caused by pressure or blows by hard objects against the finish surfaces. Dents appear the same as unmarred surfaces around them and are visible only by light reflection. Replace bearings having dents exceeding 0.003 inch (0.076 mm) in length.

c. Scratches are linear abrasions of the surface caused by other than grinding, honing, polishing, or lapping marks. Replace bearings that have scratches which can be felt with a 0.003 inch (0.076 mm) radius scribe.

d. Replace bearings that have circumferential bands on balls when they can be felt with a 0.003 inch (0.076 mm) radius scribe.

e. Corrosion may be recognized by a black or reddish rust. Replace corroded bearings.

f. Bearing fatigue is recognized by spalling of the metal appearing on load-carrying surfaces. Replace spalled bearings.

g. Replace bearings when retainer pockets are elongated, when retainer is charred or cracked, or when retainer is plated and plating has started to peel. Also replace bearings when retainer face is chipped or bore is warped, causing rubbing in two or more spots.

h. Brinelling is defined as follows:

(1) True brinelling may be recognized as small, smooth depressions on the surface of loaded area. Examine ball bearings by reflected light to determine when brinelling is present. Replace bearings showing evidence of true brinelling.

(2) False brinelling occurs only at rolling contact surfaces of bearing races, and may be recognized by the occurrence of a series of shallow indentations in the race at each roller position on the loaded side of the bearing. Replace only when bearings show evidence of failure.

i. Replace bearings showing evidence of heat failure recognized by discoloration (blueing).

j. Replace bearings having cracked or broken inner ring, rolling element, or retainer.

k. Replace bearings showing evidence of a carboned surface.

l. Inspect bearing for excessive radial and axial wear in accordance with appropriate bearing wear limits in [Table 9-2](#). Radial wear is measured 90° from the shaft or bolt which mates with the inner race or spherical ball of the bearing. Axial wear is measured parallel to the shaft or bolt which mates with the inner race or spherical ball of the bearing. Maximum wear limit values will typically be lower for radial wear than for axial wear.



BEARINGS THAT ARE SUBJECT TO HEAVY LOAD OR HIGH SPEEDS SHALL NOT BE REUSED WHEN CONDITION IS QUESTIONABLE. BEARINGS AUTHORIZED FOR EMERGENCY REUSE SHALL BE REPLACED WHEN REPLACEMENT BEARINGS ARE AVAILABLE.

2. Inspect all parts to receive a new bearing as follows:

NOTE

Damage must be removed without exceeding the limit of the maximum bore diameter specified in [Table 9-5](#).

a. Examine the bore of the part for damage and cracks with a 10X magnifying glass. No cracks are permitted and refer to the applicable manual for damage limits.

b. Deleted.

c. Inspect the edge chamfer for damage. If required, deburr or rework the edge chamfer to ensure a proper staking.

Table 9-1. Bearing Inspection and Replacement Criteria

DEFECT	CAUSE	CORRECTIVE MAINTENANCE
Cracked bearing components	Improper installation or maintenance or excessive loading	Replacement
Damaged seals	Improper installation or maintenance or excessive loading	Replacement
Charred seals	Overheating	Replacement
Roughness or binding	Grease soap deposits, fatigue spalling, contamination, corrosion, brinelling, or friction oxidation (fretting)	Lubrication or replacement
Noise	Same as previous plus lack of lubricant	Lubrication or replacement
Excessive looseness	Wear (from lack of lubricant or from contamination)	Replacement
Discoloration	Overheating	Replacement
Loose shafts or bolts	Worn bolts or bearing bores	Replacement
Corrosion	Loss of plating, lack of lubricant, or exposure to corrosive elements	Replacement

Table 9-2. Bearing Wear Limits

BEARING PART NUMBER	BEARING WEAR LIMITS MAXIMUM PLAY			
	RADIAL		AXIAL	
	(INCH)	(MM)	(INCH)	(MM)
A1460A	0.012	(0.31)	0.030	(0.76)
ABYT5-1003	0.012	(0.31)	0.030	(0.76)
AB4E59	0.005	(0.13)	0.012	(0.31)
AB4E60	0.005	(0.13)	0.012	(0.31)
AB4-75W	0.005	(0.13)	0.012	(0.31)
ADBY5V302	0.008	(0.21)	0.024	(0.61)
ADSB5V305			0.020	(0.51)
ADNE-3-306	0.012	(0.31)	0.030	(0.76)
ADN3-306	0.012	(0.31)	0.030	(0.76)
ADSB14-302			0.030	(0.76)
ADW9	0.005	(0.13)	0.010	(0.25)
AG10V64	0.005	(0.13)	0.012	(0.31)
AHT3	0.005	(0.13)	0.012	(0.31)
AJT-27930	\triangle_1			
ALK4-33	0.003	(0.08)	0.010	(0.25)
ALK4-37-101	0.010	(0.25)	0.010	(0.25)
ALK4-69-101	0.010	(0.25)	0.010	(0.25)
ALK4-111	0.005	(0.13)	0.010	(0.25)
ALK4-128			0.015	(0.39)
ALK4-156DHS/FSP			0.020	(0.51)
ALK4-172DHS-101			0.015	(0.39)
AM2002-DHS	None	None	0.010	(0.25)
AM2004-DHS	0.010	(0.25)	0.010	(0.25)
AM2011-DHS			0.020	(0.51)
AM2013-DHS			0.015	(0.39)
AM2014-DHS	0.005	(0.13)	0.030	(0.76)
AM2042-DHS			0.015	(0.39)
ARY4-35	0.005	(0.13)	0.012	(0.31)
ASBY-6-16	None	None	0.015	(0.39)

Table 9-2. Bearing Wear Limits (Cont)

BEARING PART NUMBER	BEARING WEAR LIMITS MAXIMUM PLAY			
	RADIAL		AXIAL	
	(INCH)	(MM)	(INCH)	(MM)
ASBY7V23			0.015	(0.39)
ASBV22			0.015	(0.39)
ASB8V22			0.015	(0.39)
ATBY4AAVN	0.012	(0.31)	0.030	(0.76)
ATBY4AAV7	0.012	(0.31)	0.030	(0.76)
ATBY5AAV4	0.012	(0.31)	0.030	(0.76)
ATBY5V17DHS	0.005	(0.13)	0.010	(0.25)
ATB-4	0.012	(0.31)	0.030	(0.76)
ATDY4AAV7	0.012	(0.31)	0.030	(0.76)
ATHE4-11	0.012	(0.31)	0.030	(0.76)
ATNE3-16	0.005	(0.13)	0.008	(0.21)
ATNE3-17	0.012	(0.31)	0.030	(0.76)
ATNE4-17	0.012	(0.31)	0.030	(0.76)
ATNE4-18	0.012	(0.31)	0.030	(0.76)
ATN-4-77	0.012	(0.31)	0.030	(0.76)
ATGA-107D	0.005	(0.13)	0.010	(0.25)
ATSB4AAV6	0.005	(0.13)	0.030	(0.76)
ATSB5AA2	0.012	(0.31)	0.030	(0.76)
ATSB10-301DHS			0.020	(0.51)
BR5R (Replaced by DAS5-20A-41)	\triangle		0.015	(0.39)
BSH-16-ATC32ZM	0.005	(0.13)	0.030	(0.76)
BSSN9003GRSS9				
B542DD	0.005	(0.13)	0.030	(0.76)
B542ZZ	0.005	(0.13)	0.030	(0.76)
B543DD	0.005	(0.13)	0.015	(0.39)
B545DD	0.005	(0.13)	0.015	(0.39)
DAS7-27A1-501			0.015	(0.39)
DPP3	0.006	(0.16)	0.030	(0.76)
DPP4	0.005	(0.13)	0.030	(0.76)

Table 9-2. Bearing Wear Limits (Cont)

BEARING PART NUMBER	BEARING WEAR LIMITS MAXIMUM PLAY			
	RADIAL		AXIAL	
	(INCH)	(MM)	(INCH)	(MM)
DPP8	0.005	(0.13)	0.030	(0.76)
DPP8W				
DRX-22			0.015	(0.39)
DSP3	0.006	(0.16)	0.030	(0.76)
DSP4	0.006	(0.16)	0.030	(0.76)
DSP5	0.012	(0.31)	0.030	(0.76)
DSRP4	0.006	(0.16)	0.030	(0.76)
DS-6-1	None	None	0.020	(0.51)
DW4	0.005	(0.13)	0.030	(0.76)
DW4K	0.005	(0.13)	0.030	(0.76)
DW4K2	0.005	(0.13)	0.030	(0.76)
DW5	0.005	(0.13)	0.030	(0.76)
DW6	0.005	(0.13)	0.030	(0.76)
DXV4-14A	0.003	(0.08)	0.010	(0.25)
GDW4K	0.005	(0.13)	0.030	(0.76)
GDW5	0.005	(0.13)	0.030	(0.76)
GDW6	0.005	(0.13)	0.006	(0.16)
HB4ETL141	0.012	(0.31)	0.030	(0.76)
HB4ETL142	0.012	(0.31)	0.030	(0.76)
HB4ETL144	0.012	(0.31)	0.030	(0.76)
HE6-130	0.005	(0.13)	0.030	(0.76)
HJTT162416-X1	\triangle ₅			
HJ162416	\triangle ₁			
HMXKV4A	0.012	(0.31)	0.030	(0.76)
NMXVAD	0.012	(0.31)	0.030	(0.76)
HSBY5TL103	0.012	(0.31)	0.030	(0.76)
HT5V-101			0.020	(0.51)
JH-1412-OH	\triangle ₁			
JHT-1413	\triangle ₁			

Table 9-2. Bearing Wear Limits (Cont)

BEARING PART NUMBER	BEARING WEAR LIMITS MAXIMUM PLAY			
	RADIAL		AXIAL	
	(INCH)	(MM)	(INCH)	(MM)
JT-1213			0.020	(0.51)
KBNE-6W	0.006	(0.16)	0.012	(0.31)
KDSY5-18	0.010	(0.25)	0.010	(0.25)
KLS-4	0.004	(0.11)		
KMDB8-8			0.015	(0.39)
KMVD-8-8			0.015	(0.39)
KP3A	0.005	(0.13)	0.030	(0.76)
KP4	0.006	(0.16)	0.030	(0.76)
KP4A	0.012	(0.31)	0.030	(0.76)
KP4B	0.006	(0.16)	0.030	(0.76)
KP5	0.006	(0.16)	0.030	(0.76)
KP5A	0.006	(0.16)	0.030	(0.76)
KP6A	0.005	(0.13)	0.030	(0.76)
KP8	0.006	(0.16)	0.030	(0.76)
KP-8-A	0.006	(0.16)	0.030	(0.76)
KP8ADBA2605	\triangle ₁			
KP10A	0.005	(0.13)	0.030	(0.76)
KPWD14P	0.012	(0.31)	0.030	(0.76)
KSP4	0.012	(0.31)	0.045	(1.14)
KSP4A	0.006	(0.16)	0.030	(0.76)
KSP5	0.005	(0.13)	0.030	(0.76)
KSP6A	0.006	(0.16)	0.030	(0.76)
KSP10	0.006	(0.16)	0.030	(0.76)
KWB9N	0.005	(0.13)	0.010	(0.25)
KWDB5-21				
KWDB5-48				
LHR-4-14A	0.012	(0.31)	0.030	(0.76)
LHRA-5-26	0.012	(0.31)	0.030	(0.76)
LHSSR-3	0.012	(0.31)	0.030	(0.76)

Table 9-2. Bearing Wear Limits (Cont)

BEARING PART NUMBER	BEARING WEAR LIMITS MAXIMUM PLAY			
	RADIAL		AXIAL	
	(INCH)	(MM)	(INCH)	(MM)
LHSSV-4	0.012	(0.31)	0.030	(0.76)
LHSSVV-4	0.012	(0.31)	0.030	(0.76)
LHVA-5-26	0.012	(0.31)	0.030	(0.76)
LHV-4-14	0.012	(0.31)	0.030	(0.76)
LHV-4-28	0.005	(0.13)	0.030	(0.76)
LHV5-23	0.012	(0.31)	0.030	(0.76)
LHVG5-23	0.012	(0.31)	0.030	(0.76)
LHVV-4-17A	0.010	(0.25)	0.010	(0.25)
LS-4	0.004	(0.11)		
LVH-4-14	0.012	(0.31)	0.030	(0.76)
M81935/2-4	0.012	(0.31)	0.030	(0.76)
MDW4	0.005	(0.13)	0.030	(0.76)
MDW5	0.005	(0.13)	0.030	(0.76)
MKP4	0.030	(0.76)	0.006	(0.127)
MR-16-RSS-1	\triangle ₅			
MR-1761	\triangle ₁			
MR-686	\triangle ₁			
MS14101-3	0.012	(0.31)	0.030	(0.76)
MS14101-4	0.012	(0.31)	0.030	(0.76)
MS14101-6	0.005	(0.13)	0.012	(0.31)
MS14101-7	0.012	(0.31)	0.030	(0.76)
MS14101-9	0.015	(0.39)	0.030	(0.76)
MS14103-3	0.012	(0.31)	0.030	(0.76)
MS14103-4	0.012	(0.31)	0.030	(0.76)
MS14104-3	0.012	(0.31)	0.030	(0.76)
MS20201-1	0.005	(0.13)	0.030	(0.76)
MS20206-1	0.006	(0.16)	0.030	(0.76)
MS20206DSP4	0.005	(0.13)	0.030	(0.76)
MS21150-1	0.006	(0.16)	0.015	(0.39)

Table 9-2. Bearing Wear Limits (Cont)

BEARING PART NUMBER	BEARING WEAR LIMITS MAXIMUM PLAY			
	RADIAL		AXIAL	
	(INCH)	(MM)	(INCH)	(MM)
MS21151-8	0.012	(0.31)	0.030	(0.76)
MS21151-9	0.012	(0.31)	0.030	(0.76)
MS21153-2	0.012	(0.31)	0.030	(0.76)
MS21153-6	0.005	(0.13)	0.030	(0.76)
MS21153-6C	0.012	(0.31)	0.030	(0.76)
MS21153-8	0.006	(0.16)	0.030	(0.76)
MS212345-4K	0.012	(0.31)	0.030	(0.76)
MS27640-4	0.006	(0.16)	0.030	(0.76)
MS27640-5	0.006	(0.16)	0.030	(0.76)
MS27640-8	0.006	(0.16)	0.030	(0.76)
MS27641-3	0.005	(0.13)	0.030	(0.76)
MS27641-4	0.006	(0.16)	0.030	(0.76)
MS27641-5	0.006	(0.16)	0.030	(0.76)
MS27641-6	0.005	(0.13)	0.030	(0.76)
MS27641-8	0.005	(0.13)	0.030	(0.76)
MS27641-8A	0.006	(0.16)	0.030	(0.76)
MS27641-10	0.005	(0.13)	0.030	(0.76)
MS27642-42	0.006	(0.16)	0.030	(0.76)
MS27643-3	0.006	(0.16)	0.030	(0.76)
MS27643-4	0.012	(0.31)	0.030	(0.76)
MS27643-5	0.006	(0.16)	0.030	(0.76)
MS27644-3	0.005	(0.13)	0.030	(0.76)
MS27644-4	0.005	(0.13)	0.030	(0.76)
MS27644-8	0.005	(0.13)	0.030	(0.76)
MS27645-3A	0.005	(0.13)	0.030	(0.76)
MS27645-4	0.006	(0.16)	0.030	(0.76)
MS27645-4A	0.005	(0.13)	0.034	(0.86)
MS27645-5	0.006	(0.16)	0.030	(0.76)
MS27645-6A	0.005	(0.13)	0.034	(0.86)

Table 9-2. Bearing Wear Limits (Cont)

BEARING PART NUMBER	BEARING WEAR LIMITS MAXIMUM PLAY			
	RADIAL		AXIAL	
	(INCH)	(MM)	(INCH)	(MM)
MS27645-10	0.006	(0.16)	0.030	(0.76)
MS27646-38	0.005	(0.13)	0.030	(0.76)
MS27646-40	0.005	(0.13)	0.030	(0.76)
MS27646-41	0.005	(0.13)	0.030	(0.76)
MS27646-42	0.005	(0.13)	0.030	(0.76)
MS27646-43	0.005	(0.13)	0.030	(0.76)
MS27646-45	0.005	(0.13)	0.015	(0.39)
MS27647-4	0.005	(0.13)	0.030	(0.76)
MS27647-4A	0.005	(0.13)	0.030	(0.76)
MS27647-5	0.005	(0.13)	0.030	(0.76)
MS27647-5G	0.005	(0.13)	0.006	(0.15)
MS27647-6	0.005	(0.13)	0.030	(0.76)
MS27647-6G	0.005	(0.13)	0.006	(0.16)
MS27648-24	0.005	(0.13)	0.030	(0.76)
MS27648-25	0.012	(0.31)	0.030	(0.76)
MS28913-4B			0.003	(0.08)
MS28913-4C	\triangle_1		0.015	(0.39)
MS28913-5C (Replaced by DAS5-20A-41)	\triangle_1		0.015	(0.39)
MV34-14A	0.005	(0.13)	0.008	(0.21)
MV34-14B	0.012	(0.31)	0.030	(0.76)
MXLR-46-14H	\triangle_3 0.003	(0.08)	0.030	(0.76)
MXLV46-14E	0.012	(0.31)	0.030	(0.76)
MXV46-14B	0.012	(0.31)	0.030	(0.76)
MXV46-14D	0.012	(0.31)	0.030	(0.76)
MX46-14B	0.012	(0.31)	0.030	(0.76)
M9312W1CRDF	\triangle_1			
NHBY5AA5	0.005	(0.13)	0.010	(0.25)
NHB12V7			0.010	(0.25)
NHHE6-21W	0.006	(0.16)	0.012	(0.31)

Table 9-2. Bearing Wear Limits (Cont)

BEARING PART NUMBER	BEARING WEAR LIMITS MAXIMUM PLAY			
	RADIAL		AXIAL	
	(INCH)	(MM)	(INCH)	(MM)
NHNEL5-212	0.012	(0.31)	0.030	(0.76)
NHNE4-221	0.012	(0.31)	0.030	(0.76)
NHN5-209	0.007	(0.18)	0.015	(0.39)
NHSB8V9	0.012	(0.31)	0.030	(0.76)
NHW4V202			0.015	(0.39)
NHW5V202			0.015	(0.39)
NHW7V203			0.010	(0.25)
RAD-4T-1	0.005	(0.13)	0.030	(0.76)
RALT-4N-1	0.012	(0.31)	0.030	(0.76)
RALT5N7	0.012	(0.31)	0.030	(0.76)
RALT-5-N7V	0.012	(0.31)	0.030	(0.76)
RALT-5-4	0.012	(0.31)	0.030	(0.76)
RAPG-4N-2	0.012	(0.31)	0.030	(0.76)
RDW-5T-3V-1	0.005	(0.13)	0.015	(0.39)
RLA-4T-1	0.003	(0.08)	0.010	(0.25)
REF4THB	0.005	(0.13)	0.010	(0.25)
REM-3T-3	0.005	(0.13)	0.008	(0.21)
REM-3T-8	0.012	(0.31)	0.030	(0.76)
REM-4TH-6-1	0.012	(0.31)	0.030	(0.76)
REM-4-TH-16	0.012	(0.31)	0.030	(0.76)
REM4TH16-1	0.012	(0.31)	0.030	(0.76)
REM4TH16-2	0.012	(0.31)	0.030	(0.76)
REM4TH17	0.012	(0.31)	0.030	(0.76)
REM8ATC12-5	0.012	(0.31)	0.030	(0.76)
REM8ATC12-6	0.012	(0.31)	0.030	(0.76)
REM8ATC12-11	0.012	(0.31)	0.030	(0.76)
REML10Z12A1460A	0.012	(0.31)	0.030	(0.76)
REPB3N	0.012	(0.31)	0.030	(0.76)
REPB3N-2	0.012	(0.31)	0.030	(0.76)

Table 9-2. Bearing Wear Limits (Cont)



BEARING PART NUMBER	BEARING WEAR LIMITS MAXIMUM PLAY			
	RADIAL		AXIAL	
	(INCH)	(MM)	(INCH)	(MM)
REP3M4-9-FS21D	0.005	(0.13)	0.008	(0.21)
REP3M4-10-FS21D	0.012	(0.31)	0.030	(0.76)
REP4F5	0.005	(0.13)	0.030	(0.76)
REP4ML6	0.006	(0.16)	0.015	(0.39)
REP4M6-8	0.012	(0.31)	0.030	(0.76)
RES8ATC10-2	0.012	(0.31)	0.030	(0.76)
RG9SS	0.015	(0.39)	0.030	(0.76)
RG-12-SS	0.015	(0.39)	0.030	(0.76)
RSST-3	0.012	(0.31)	0.030	(0.76)
RSST-4	0.012	(0.31)	0.030	(0.76)
RSST-5N7V	0.008	(0.21)	0.024	(0.61)
SBSH14ATC30ZA1501			0.010	(0.25)
SBS16ATC50ZA1460	0.006	(0.16)	0.030	(0.76)
SBS24ATC46ZA1501			0.010	(0.25)
SJT194-13-S5				
SJ-7154-SX-1TU-9D-1				
SPS4-10A1-501	0.012	(0.31)	0.030	(0.76)
S-4	0.004	(0.11)		
TGA104N			0.015	(0.39)
TGA-14F	0.006	(0.16)	0.030	(0.76)
TGA-14G	0.006	(0.16)	0.030	(0.76)
T6A-12G	None	None	0.015	(0.39)
VTB02220	0.005	(0.13)	0.012	(0.31)
VTBO2310	0.005	(0.13)	0.012	(0.31)
WBS10FTF-29	0.012	(0.31)	0.030	(0.76)
WHT9	0.005	(0.13)	0.010	(0.25)
WSBS10FTF-29Z	0.012	(0.31)	0.030	(0.76)
WSBS12ATC29	0.008	(0.21)	0.024	(0.61)
W202PP	0.005	(0.13)	0.030	(0.76)

Table 9-2. Bearing Wear Limits (Cont)



BEARING PART NUMBER	BEARING WEAR LIMITS MAXIMUM PLAY			
	RADIAL		AXIAL	
	(INCH)	(MM)	(INCH)	(MM)
YD241A	None	None	0.020	(0.51)
YS-1125	0.005	(0.13)	0.030	(0.76)
YTA-178	0.005	(0.13)	0.030	(0.76)
YTA190B	0.012	(0.31)	0.030	(0.76)
YTA227-11	0.005	(0.13)	0.030	(0.76)
YTA-354			0.015	(0.39)
YTA373			0.015	(0.39)
YTA-384			0.030	(0.76)
YTA-385			0.020	(0.51)
12-2000-12	0.015	(0.39)	0.030	(0.76)
174PH	0.005	(0.13)	0.030	(0.76)
176260	0.012	(0.31)	0.030	(0.76)
177182	0.012	(0.31)	0.030	(0.76)
177183	0.012	(0.31)	0.030	(0.76)
177184	0.012	(0.31)	0.030	(0.76)
177293	0.012	(0.31)	0.030	(0.76)
47-140-252-3	0.012	(0.31)	0.030	(0.76)
204-001-058-003	0.005	(0.13)	0.030	(0.76)
204-001-064-001	0.012	(0.31)	0.030	(0.76)
204-001-064-003	0.012	(0.31)	0.030	(0.76)
204-011-118-001	None	None	0.020	(0.51)
204-011-418-001				
204-011-451-001	None	None	0.020	(0.51)
204-011-769-001			None	None
204-061-717-001	0.005	(0.13)	0.008	(0.21)
204-061-717-003	0.012	(0.31)	0.030	(0.76)
204-076-428-001	0.012	(0.31)	0.030	(0.76)
205-001-047-001	 0.003	(0.08)	0.030	(0.76)
205-001-048-001	0.012	(0.31)	0.030	(0.76)

Table 9-2. Bearing Wear Limits (Cont)

BEARING PART NUMBER	BEARING WEAR LIMITS MAXIMUM PLAY			
	RADIAL		AXIAL	
	(INCH)	(MM)	(INCH)	(MM)
205-012-710-001			0.015	(0.39)
206-001-005-001	0.012	(0.31)	0.030	(0.76)
206-001-052-001	0.012	(0.31)	0.030	(0.76)
206-001-053-001	0.012	(0.31)	0.030	(0.76)
206-001-053-003	0.012	(0.31)	0.030	(0.76)
206-001-053-005	0.012	(0.31)	0.030	(0.76)
206-001-054-001	0.012	(0.31)	0.030	(0.76)
206-001-055-001	0.012	(0.31)	0.030	(0.76)
206-001-057-001	0.012	(0.31)	0.030	(0.76)
206-001-057-003	0.012	(0.31)	0.030	(0.76)
206-001-063	0.012	(0.31)	0.030	(0.76)
206-001-095-001	0.012	(0.31)	0.030	(0.76)
206-001-159	0.003	(0.08)	0.010	(0.25)
206-001-201-001	0.005	(0.13)	0.010	(0.25)
206-001-202-001	0.005	(0.13)	0.010	(0.25)
206-001-204-101	0.005	(0.13)	0.010	(0.25)
206-001-556	0.005	(0.13)	0.030	(0.76)
206-001-701-001	0.003	(0.08)	0.010	(0.25)
206-001-708-001		\triangle 4		
206-010-469-001	0.010	(0.25)	0.010	(0.25)
206-010-470-101	0.010	(0.25)	0.010	(0.25)
206-010-710-3	0.010	(0.25)	0.010	(0.25)
206-010-765-001			0.015	(0.39)
206-010-792-107			0.020	(0.51)
206-010-793-101	0.010	(0.25)	0.010	(0.25)
206-031-590-003			0.010	(0.25)
206-031-594-003			0.010	(0.76)
206-063-719	0.005	(0.13)	0.030	(0.76)
206-064-103-001	0.000	(0.00)	0.006	(0.156)

Table 9-2. Bearing Wear Limits (Cont)

BEARING PART NUMBER	BEARING WEAR LIMITS MAXIMUM PLAY			
	RADIAL		AXIAL	
	(INCH)	(MM)	(INCH)	(MM)
206-301-051-101	0.005	(0.13)	0.010	(0.25)
206-310-105-101			0.015	(0.39)
209-001-051-001	0.012	(0.31)	0.030	(0.76)
209-001-052-001	0.012	(0.31)	0.030	(0.76)
209-001-053-001	0.005	(0.13)	0.030	(0.76)
209-001-055-001	0.005	(0.13)	0.030	(0.76)
209-010-444	\triangle_5			
209-010-459-001			0.015	(0.39)
209-031-351-001	0.015	(0.39)	0.030	(0.76)
209-062-105-001	0.005	(0.13)	0.010	(0.25)
209-062-109-001	0.005	(0.13)	0.030	(0.76)
212-001-066-001	0.005	(0.13)	0.030	(0.76)
212-010-730-001	0.007	(0.18)	0.015	(0.39)
212-010-783-101	0.007	(0.18)	0.015	(0.39)
212-010-731-001	None	None	0.015	(0.39)
212-010-762-001	\triangle_1		0.020	(0.51)
212-010-768-001			0.015	(0.39)
212-010-782-101			0.015	(0.39)
212-010-783-101	0.007	(0.18)	0.015	(0.39)
212-061-117-001	0.005	(0.13)	0.030	(0.76)
214-001-049-001	0.012	(0.31)	0.030	(0.76)
214-001-082-001	0.006	(0.16)	0.015	(0.39)
214-001-083-001	0.006	(0.16)	0.030	(0.76)
214-001-083-003	0.006	(0.16)	0.030	(0.76)
214-001-093	0.005	(0.13)	0.030	(0.76)
214-001-424	0.006	(0.16)	0.030	(0.76)
214-010-434-001			0.015	(0.39)
214-010-435-003			0.015	(0.39)
214-010-437			0.030	(0.76)

Table 9-2. Bearing Wear Limits (Cont)

BEARING PART NUMBER	BEARING WEAR LIMITS MAXIMUM PLAY			
	RADIAL		AXIAL	
	(INCH)	(MM)	(INCH)	(MM)
214-010-487-001	0.020	(0.50)	0.030	(0.76)
214-010-489-101	0.020	(0.50)	0.030	(0.76)
214-010-711-001			0.015	(0.39)
214-010-712-001			0.015	(0.39)
214-010-714-001	△ ₂			
214-010-733-001			0.015	(0.39)
214-010-736-001	△ ₂			
214-010-744-001	△ ₂			
214-010-777-101			0.015	(0.39)
214-010-815-101			0.015	(0.39)
214-010-850-101			0.015	(0.39)
214-010-851-103			0.015	(0.39)
214-010-856-103	△ ₁ △ ₂			
214-011-811-103			0.015	(0.39)
214-011-819-101			0.015	(0.39)
214-030-146-101	0.005	(0.13)	0.015	(0.39)
214-030-216-001	0.004	(0.11)		
214-030-633-001	0.008	(0.21)	0.024	(0.61)
222-301-011-101	0.012	(0.31)	0.030	(0.76)
222-301-012-101	0.012	(0.31)	0.030	(0.76)
222-301-013-101	0.012	(0.31)	0.030	(0.76)
222-310-119-101	△ ₁			
222-310-401-101			0.015	(0.39)
222-310-460-103			0.015	(0.39)
222-310-461-001			0.015	(0.39)
222-310-473-001	△ ₁			
222-310-473-103	△ ₁			
222-310-475-001			0.020	(0.51)
222-310-475-103			0.020	(0.51)

Table 9-2. Bearing Wear Limits (Cont)







BEARING PART NUMBER	BEARING WEAR LIMITS MAXIMUM PLAY			
	RADIAL		AXIAL	
	(INCH)	(MM)	(INCH)	(MM)
222-310-478-101			0.020	(0.51)
222-310-479-101				
222-312-718-001				
222-312-719-001				
222-312-751-001			0.015	(0.39)
222-312-752-001			0.015	(0.39)
222-312-753-101			0.015	(0.39)
222-312-754-101			0.020	(0.51)
222-312-755-101			0.020	(0.15)
222-312-760-001				
230-360-101-103	0.005	(0.13)	0.012	(0.31)
406-310-403-101	0.005	(0.13)	0.012	(0.31)
406-310-405-101	None	None	0.015	(0.39)
406-310-405-103	None	None	0.015	(0.39)
409-360-706-001	0.005	(0.13)	0.015	(0.39)
412-010-427-101			0.015	(0.39)
412-320-400-107				
4708			None	None
47-140-252-5	0.012	(0.31)	0.030	(0.76)
47-729-155-3	0.012	(0.31)	0.030	(0.76)
50294	0.005	(0.13)	0.010	(0.25)
5103-J2-1			0.020	(0.51)
540-011-414-1	0.005	(0.13)	0.030	(0.76)
542ZZ	0.005	(0.13)	0.030	(0.76)
59100W01-2-MBR-A1835				
60-BAA-4802				
604-14-34-01			0.030	(0.76)
7203-D4F				
76546	0.005	(0.13)	0.030	(0.76)

Table 9-2. Bearing Wear Limits (Cont)

BEARING PART NUMBER	BEARING WEAR LIMITS MAXIMUM PLAY			
	RADIAL		AXIAL	
	(INCH)	(MM)	(INCH)	(MM)
76549	0.012	(0.31)	0.030	(0.76)
76569	0.012	(0.31)	0.030	(0.76)
76585	0.012	(0.31)	0.030	(0.76)
76684	0.005	(0.13)	0.010	(0.25)
9101PP	0.005	(0.13)	0.030	(0.76)
9103PP	0.005	(0.13)	0.030	(0.76)
9104NPP	0.005	(0.13)	0.015	(0.39)
9104PP	0.005	(0.13)	0.015	(0.39)
9104VPP	0.005	(0.13)	0.030	(0.76)

NOTES:

- 1 Inspect for smoothness during manual rotation, replace if rough.
- 2 Bearing Condition: Smooth during rotation while loading axially and radially.
- 3 Bearing has built in radial clearance of 0.0012 to 0.002 inch (0.0305 to 0.0508 mm) between ball and outer race.
- 4 Oilite bearing used as friction surface.
- 5 Check for roughness or binding.

9-4. BEARINGS — REPLACEMENT

SPECIAL TOOLS REQUIRED

NUMBER	NOMENCLATURE
T101886-1 or RST2020	Roll Staking Tool
T102095	Anvil Staking Tool Set
RST1016	Roll Staking Tool
Workaid Item (Figure 9-1)	Bearing/Sleeve Removal and Installation Tool Set

The following instructions contain information on bearings which may be removed, installed, and retained through staking. Table 9-5 provides the dimensions, type of bearing staking, tool number, bearing part number, sleeve part number, and other applicable data for various parts and assemblies. Bellcranks, levers, etc. are listed in numerical order in the table.

Unless otherwise specified in Table 9-5, the following general fits and clearances are provided to ensure proper installation of bearings:

- Bearings must have a 0.0002 to 0.0012 inch (0.0051 to 0.0305 mm) tight fit in sleeves or housings.
- Sleeves must have a 0.0002 to 0.0022 inch (0.0051 to 0.0559 mm) tight fit in housings.
- Bearings installed with an anaerobic sealing compound must have a 0.0005 to 0.0010 inch (0.0127 to 0.0254 mm) clearance between the bearing and the housing.

9-5. Bearing Removal

MATERIALS REQUIRED

Refer to Chapter 13 for specifications.

NUMBER	NOMENCLATURE
C-309	MEK
C-407	Abrasive Pad
C-486	Cheesecloth

1. Remove an unserviceable sleeve and/or bearing from the part with the bearing/sleeve removal and installation tool set as follows (refer to Figure 9-1 for details on construction of the workaids):



BEFORE PRESSING OUT A PREGROOVED BEARING WITH A STEEL OUTER RACE, CAREFULLY CUT AWAY AND REMOVE ROLL STAKED LIP ON ONE SIDE OF BEARING USING A FLY CUTTER. DO NOT CUT INTO PART.

- a. Put the part in a press with the unserviceable bearing over the fabricated support tool.
- b. Press out the bearing with the small end of the fabricated pressing tool. Press out the sleeve with the large end of the fabricated pressing tool.
- c. Thoroughly clean the bore of the part with MEK (C-309) and an abrasive pad (C-407). Wipe dry with clean cheesecloth (C-486) before the MEK (C-309) evaporates.

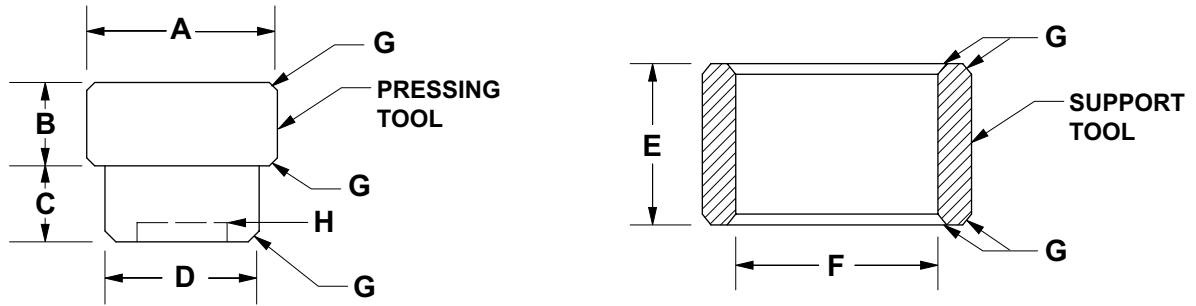

MATERIAL: ANY ROUND ALLOY STOCK

NO.	REF LTR	DIMENSIONS
1	A	Slightly smaller than sleeve outside diameter.
2	B	Two times the bearing length.
3	C	Two times the bearing width.
4	D	Slightly smaller than bearing inside diameter.
5	E	Slightly longer than bearing or sleeve height/length.
6	F	Slightly larger than bearing or sleeve O.D.
7	G	Chamfer 0.025 inch (0.635 mm) by 45°.
8	H	Undercut 0.4 inch (10.16 mm) to provide clearance for shoulder diameter bearing inner ring.

ALL_SPM_09_0001

Figure 9-1. Bearing/Sleeve Removal and Installation Workaids

9-6. Bearing Installation — Ring Staking Method

CAUTION

MATERIALS REQUIRED

Refer to [Chapter 13](#) for specifications.

NUMBER	NOMENCLATURE
C-304	Drycleaning Solvent
C-486	Cheesecloth

Ring staking is used on steel and aluminum sleeves. Ring stake is centered on the sleeve and lays over a portion of sleeve to the part and a portion of sleeve to the bearing as shown in [Figure 9-2](#). Refer to [Table 9-3](#) for the applicable tools.

1. Ring stake as follows:

EXTREME CARE MUST BE EXERCISED TO AVOID ANY CONTAMINATION OF BEARING DURING ALL PHASES OF HANDLING AND INSTALLATION.

a. Measure the bore of the part, new bearing, and new bearing sleeve to make sure dimensions will provide the interference fit given in [Table 9-5](#).

b. Apply coating, as specified in [Table 9-5](#), to the outside diameter of the new sleeve and to the mating bore in the part.

c. While coating is wet, press the sleeve into the part with the bearing/sleeve removal and installation tool set ([Figure 9-1](#)). The sleeve must be equally centered from each side of the part.

d. Apply coating, as specified in [Table 9-5](#), to the outside diameter of a new bearing and to the inside diameter of the previously installed sleeve. Avoid excessive application of coating and do not apply to the bearing seals or shields.

Table 9-3. Staking Tool Set Application

TOOL PART NO.	SLEEVE PART NO.	MANUFACTURER'S BEARING PART NO.	MILITARY STANDARD BEARING PART NO.
T101873-3	120-012-4	KP4A	MS27641-4
	120-015-4K	DW4K	MS27647-4
T101873-5	120-011-3	KP3 and KS3	MS27640-3
	120-013-3	DSP3 and DSRP3	MS27643-3
	120-014-3	DPP3	MS67644-3
T101873-7	120-012-5	KP5A	MS27641-5
T101873-9	120-012-6	KP6A	MS27641-6
T101873-11	120-015-5	DW5	MS27647-5
T101873-13	120-011-4	KP4 and KS4	MS27640-4
	120-013-4	DSP4 and DSRP4	MS27643-4
	120-014-4	DPP4	MS27644-4
T101873-15	120-015-6	DW6	MS27647-6

Table 9-3. Staking Tool Set Application (Cont)

TOOL PART NO.	SLEEVE PART NO.	MANUFACTURER'S BEARING PART NO.	MILITARY STANDARD BEARING PART NO.
T101873-17	120-012-8	KP8A	MS27641-8
T101873-19	120-011-5	KP5 and KS5	MS27640-5
	120-013-5	DSP5 and DSRP5	MS27643-5
	120-014-5	DPP5	MS27644-5
T102095-1	None	209-001-005-1	N/A
T102095-3	None	209-011-051-1	N/A

NOTE:

The table is for the T102095 staking tool set and is primary for flight controls.



DURING BEARING INSTALLATION, MAKE SURE YOU APPLY PRESSURE ONLY TO THE OUTER RACE. DO NOT APPLY PRESSURE TO THE INNER RACE AND SPHERICAL BALL OF THE BEARING OR DAMAGE MAY OCCUR.

e. While coating is wet, press the new bearing into the sleeve with the bearing/sleeve removal and installation tool set (Figure 9-1). The bearing must be equally centered from each side of the part.

f. Select the applicable ring staking tool given in Table 9-5. Ring stake to obtain required dimensions on both sides of the sleeve (Figure 9-2).

g. Clean any excess coating with clean cheesecloth (C-486) moistened with drycleaning solvent (C-304).

h. Make sure there is no movement or looseness of the bearing outer race in the bore of the part.

i. Proof load the bearing if required (Table 9-5).

j. Examine the bearing for smooth rotation and breakout (misalignment), breakaway or rotational (roll) torque (Table 9-5).

9-7. Pregrooved Bearing Installation — Roll Staking Method

MATERIALS REQUIRED

Refer to Chapter 13 for specifications.

NUMBER	NOMENCLATURE
C-304	Drycleaning Solvent
C-486	Cheesecloth

Roll staking is used for the staking of pregrooved spherical bearings to the part by rolling over the pregrooved lip of the bearing onto the chamfer of the hole in the part, as shown in Figure 9-3.

1. Roll stake as follows:



EXTREME CARE MUST BE EXERCISED TO AVOID ANY CONTAMINATION OF BEARING DURING ALL PHASES OF HANDLING AND INSTALLATION.

a. Measure the bore of the part and the outside diameter of a new bearing to make sure dimensions will provide the proper fit given in Table 9-5.

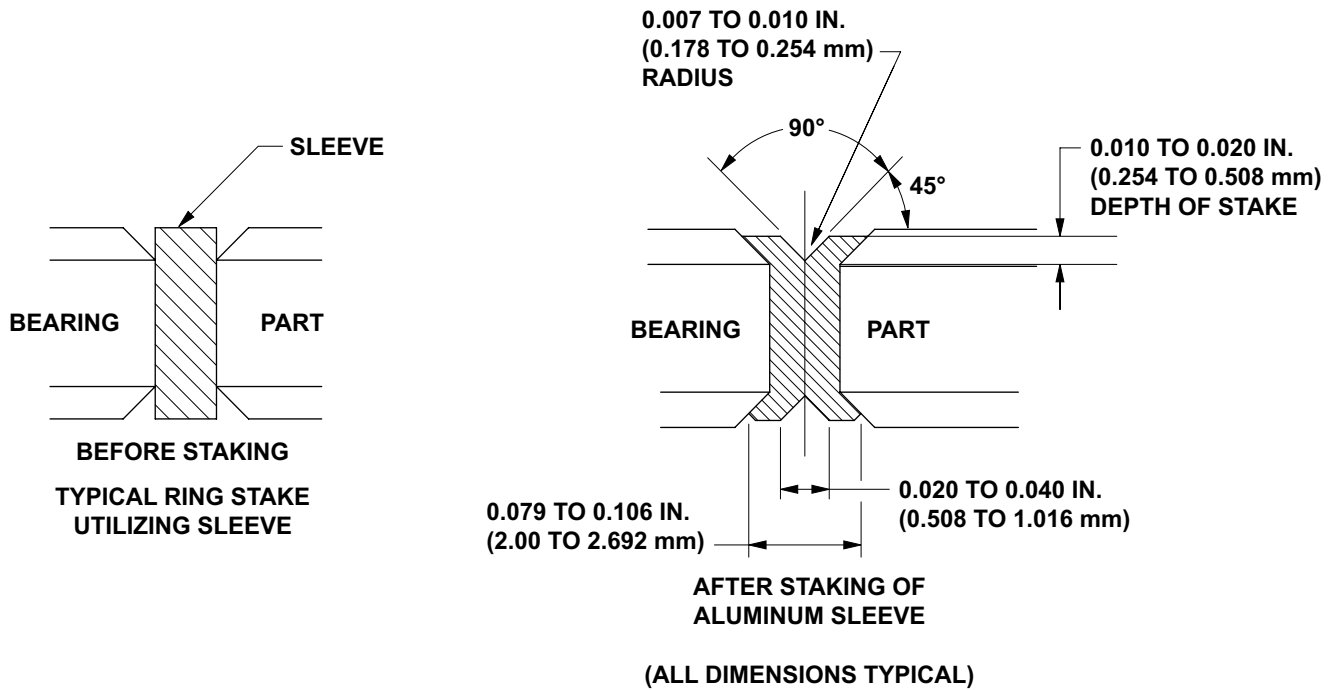
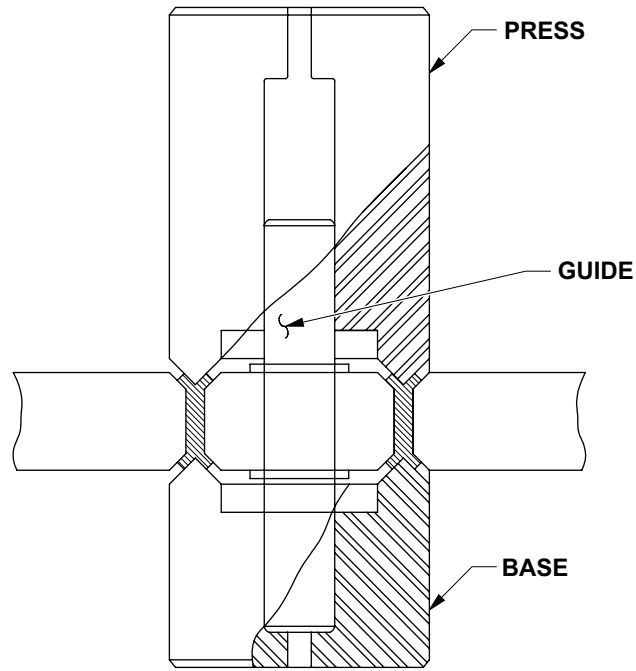
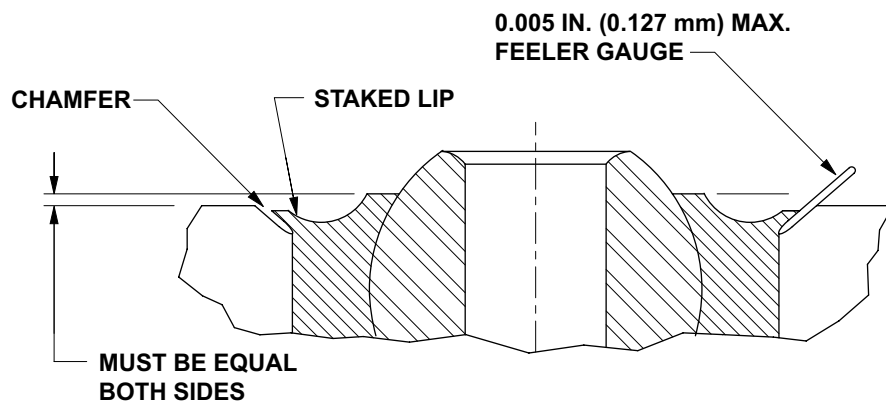

Figure 9-2. Ring Staking

ALL_SPM_09_0002



ALL_SPM_09_0003

Figure 9-3. Roll or Anvil Staking Pregrooved Bearings

b. Apply coating, as specified in [Table 9-5](#), to the outside diameter of the new bearing and to the mating bore in the part.

CAUTION

DURING BEARING INSTALLATION, MAKE SURE YOU APPLY PRESSURE ONLY TO THE OUTER RACE. DO NOT APPLY PRESSURE TO THE INNER RACE AND SPHERICAL BALL OF THE BEARING OR DAMAGE MAY OCCUR.

c. While coating is wet, press the bearing into the part with the bearing/sleeve removal and installation tool set ([Figure 9-1](#)). The bearing must be equally centered from each side of the part.

d. Select the applicable roll staking tool given in [Table 9-5](#).

NOTE

The base (or backstop) receives the inner race of the bearing and supports the outer race during staking.

The roller fixture (or spinning tool) has a pilot on the lower end that goes into the inner race, roller wheels that contact the groove in the outer race, and a shank that mounts in a drill press.

e. Install the roll staking tool in a hand-fed drill press. Set the spindle to a speed of 200 to 350 RPM.

CAUTION

DO NOT LET THE BEARING OVERHEAT DURING STAKING (SPINNING). IF IT BECOMES UNCOMFORTABLE TO HOLD THE BEARING WITH BARE HANDS, THE BEARING IS DAMAGED AND MUST BE REPLACED.

NOTE

Undue forcing of the roll staking tool into the outer lip of the pregrooved bearing will

cause excessive stress and binding of the staked bearing.

f. After you start the drill press, roll stake both sides of the bearing as follows:

(1) Carefully apply a small quantity of oil to the area of staking and to the staking rollers immediately prior to staking.

NOTE

The bearing must be centered in the part and staked the same amount on both sides. To meet this requirement, it may be necessary to partially stake one side, stake the opposite side, then reverse bearing back to first side and finish staking.

(2) Apply a steady pressure to the lever of the drill press in 10 second intervals. This will allow rollers to move the outer race lip of the bearing onto the chamfer of the part.

(3) Repeat staking on the other side of the bearing in the same way.

(4) After staking, remove oil completely with clean cheesecloth ([C-486](#)) moistened with drycleaning solvent ([C-304](#)).

g. Examine the bearing for correct installation as follows:

(1) Make sure the gap between the chamfer of the part and the staked (rolled) lip of the bearing outer race is no more than 0.005 inch (0.127 mm), as shown in [Figure 9-3](#). As required, stake the bearing again.

(2) Make sure there is no movement or looseness of the bearing outer race in the bore of the part.

(3) Make sure the bearing is centered in the part.

h. Examine the bearing for smooth rotation.

i. Proof load the bearing if required ([Table 9-5](#)).

j. If applicable, do a check of the breakout (misalignment), breakaway or rotational (roll) torque of

the bearing as follows (refer to [Table 9-5](#) for specific requirements):

(1) Secure a bolt to the bearing inner race with nuts and washers and rotate the race with a torque wrench, or use a spring scale attached to the bolt ([Figure 9-4](#)).

9-8. Bearing Installation — Roll Staking Method

MATERIALS REQUIRED

Refer to [Chapter 13](#) for specifications.

NUMBER	NOMENCLATURE
C-304	Drycleaning Solvent
C-486	Cheesecloth

Roll staking is used for aluminum sleeves. The sleeve is placed between the bearing and the enlarged bore of the housing. Swaging the extended part of the sleeve provides both axial retention and radial tightness, as shown in [Figure 9-5](#).

1. Roll stake as follows:



EXTREME CARE MUST BE EXERCISED TO AVOID ANY CONTAMINATION OF BEARING DURING ALL PHASES OF HANDLING AND INSTALLATION.

a. Measure the bore of the part, new bearing, and new bearing sleeve to make sure dimensions will provide the correct fit given in [Table 9-5](#).

b. Apply coating, as specified in [Table 9-5](#), to the outside diameter of the new sleeve and to the mating bore in the part.

c. While coating is wet, press the sleeve into the part with the bearing/sleeve removal and installation

tool set ([Figure 9-1](#)). The sleeve must be equally centered from each side of the part.

d. Make sure the inside diameter of the sleeve meets the hole size for the bearing, as specified in [Table 9-5](#). Ream the sleeve to the required diameter if necessary.

e. Apply coating, as specified in [Table 9-5](#), to the outside diameter of the bearing and to the inside diameter of the previously installed sleeve. Avoid excessive application of coating and do not apply to bearing seals or shields.



DURING BEARING INSTALLATION, MAKE SURE YOU APPLY PRESSURE ONLY TO THE OUTER RACE. DO NOT APPLY PRESSURE TO THE INNER RACE AND SPHERICAL BALL OF THE BEARING OR DAMAGE MAY OCCUR.

f. While coating is wet, press the new bearing into the sleeve with the bearing/sleeve removal and installation tool set ([Figure 9-1](#)). The bearing must be equally centered from each side of the part.

g. Select the applicable roll staking tool given in [Table 9-5](#).

h. Install the roll staking tool in a hand-fed drill press. Set the spindle to a speed of 200 to 350 RPM.

i. After you start the drill press, roll stake both sides of the sleeve as follows ([Figure 9-5](#)):

NOTE

The bearing must be centered in the part and staked a same amount on both sides. To meet this requirement, it may be necessary to partially stake one side, stake the opposite side, then reverse bearing back to first side and finish staking.

(1) Apply a steady pressure to the lever of the drill press in 10 second intervals. This will allow rollers to flow the metal out.

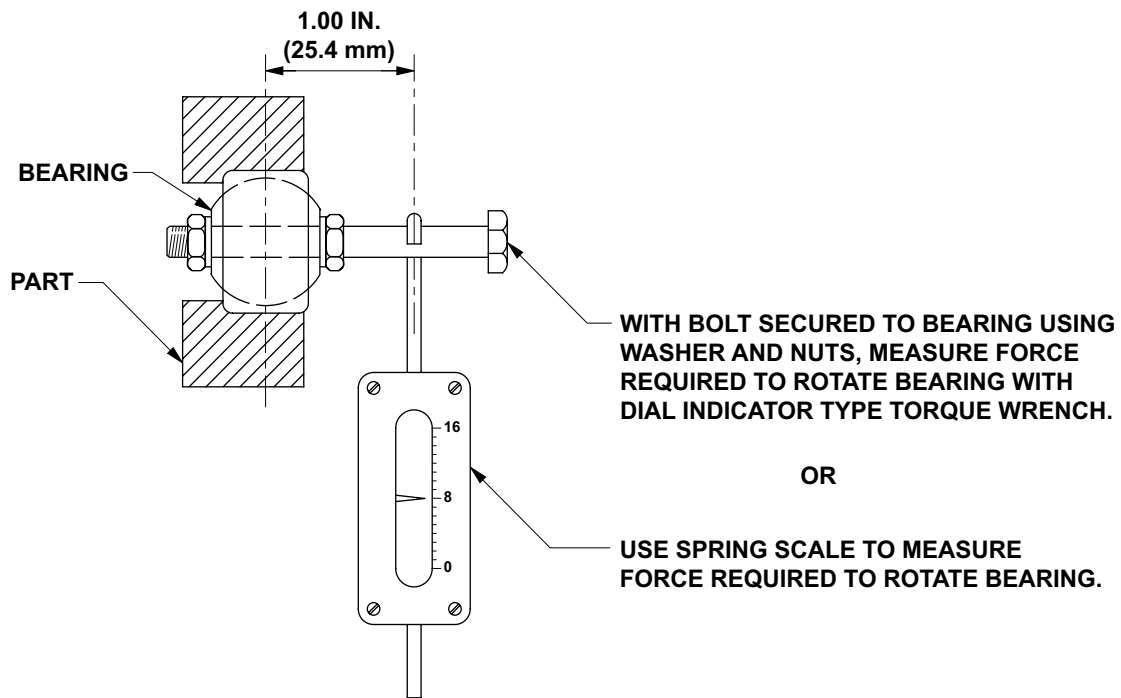

ALL_SPM_09_0004

Figure 9-4. Bearing Rotational Torque Check

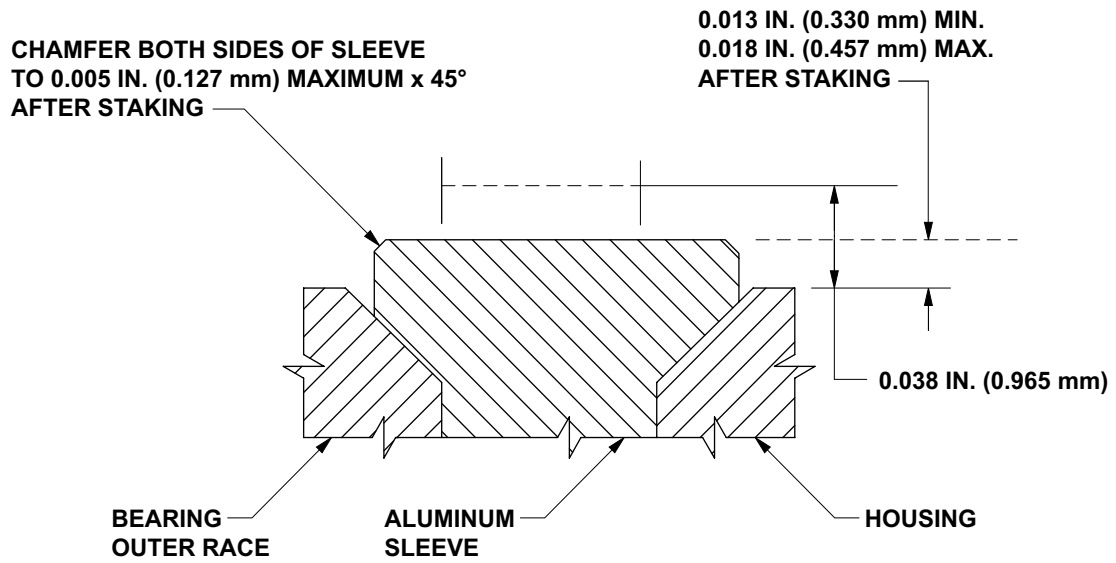

ALL_SPM_09_0005

Figure 9-5. Roll Staking Sleeves or Bushings

(2) Repeat staking on the other side of the sleeve in the same way.

j. Clean any excess coating with clean cheesecloth (C-486) moistened with drycleaning solvent (C-304).

k. Chamfer both sides of the sleeve to 0.005 inch (0.127 mm) maximum by 45°.

l. Make sure there is no movement or looseness of the bearing outer race in the bore of the part.

m. Proof load the bearing if required (Table 9-5).

n. Examine the bearing for smooth rotation and, if applicable, do a check of the breakout (misalignment), breakaway or rotational (roll) torque (Table 9-5).

9-9. Bearing Installation — Segment Staking Method

MATERIALS REQUIRED

Refer to Chapter 13 for specifications.

NUMBER	NOMENCLATURE
C-304	Drycleaning Solvent
C-486	Cheesecloth

NOTE

As segment staking uses the parent metal of the housing to retain the bearing, subsequent bearing replacement using the same housing is not authorized.

Segment staking is used on steel housings and trunnions/axles. Segment staking retains the outer bearing race by staking parent metal of the housing, as shown in Figure 9-6.

1. Segment stake as follows:



EXTREME CARE MUST BE EXERCISED TO AVOID ANY CONTAMINATION OF BEARING DURING ALL PHASES OF HANDLING AND INSTALLATION.

a. Measure the bore of the part and the outside diameter of a new bearing to make sure dimensions will provide the interference fit given in Table 9-5.

b. Apply coating, as specified in Table 9-5, to the outside diameter of the new bearing and to the mating bore in the part.



DURING BEARING INSTALLATION, MAKE SURE YOU APPLY PRESSURE ONLY TO THE OUTER RACE. DO NOT APPLY PRESSURE TO THE INNER RACE AND SPHERICAL BALL OF THE BEARING OR DAMAGE MAY OCCUR.

c. While coating is wet, press the bearing into the part with the bearing/sleeve removal and installation tool set (Figure 9-1). The bearing must be equally centered from each side of the part.

d. Select the applicable segment staking tool given in Table 9-5. Segment stake to obtain required dimensions on both sides of the part (Figure 9-6).

e. Clean any excess coating with clean cheesecloth (C-486) moistened with drycleaning solvent (C-304).

f. Examine the bearing for smooth rotation.

g. If applicable, do a check of the breakout (misalignment), breakaway or rotational (roll) torque of the bearing as follows (refer to Table 9-5 for specific requirements):

(1) Secure a bolt to the bearing inner race with nuts and washers and rotate the race with a torque wrench, or use a spring scale attached to the bolt (Figure 9-4).

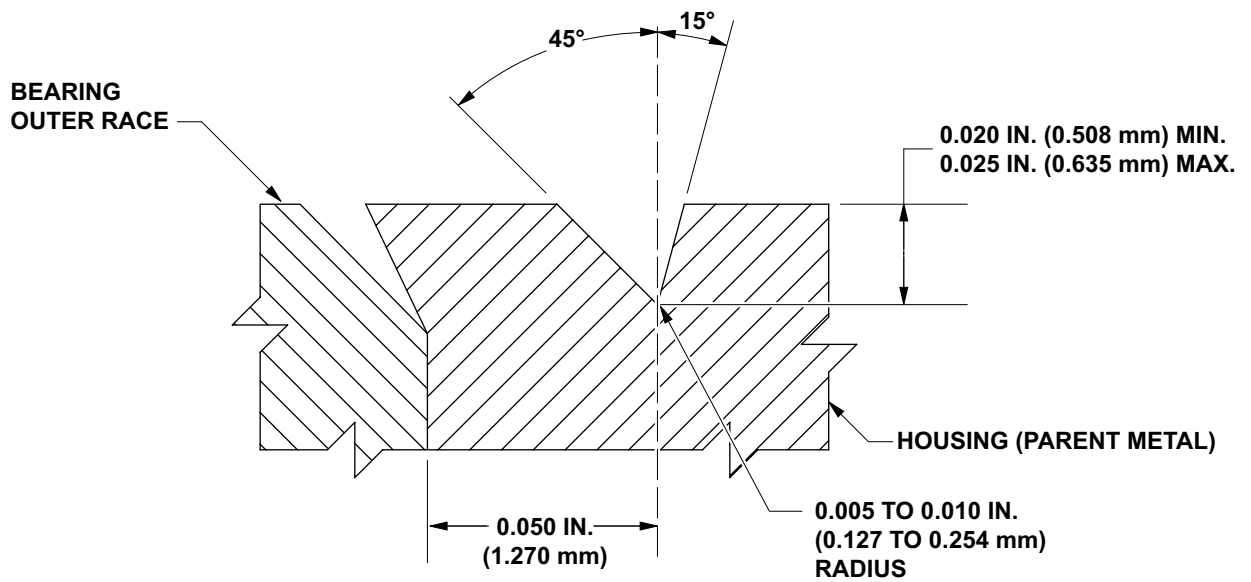

ALL_SPM_09_0006

Figure 9-6. Segment Staking

9-10. Pregrooved Bearing Installation — Anvil Staking Method

MATERIALS REQUIRED

Refer to [Chapter 13](#) for specifications.

NUMBER	NOMENCLATURE
C-304	Drycleaning Solvent
C-486	Cheesecloth

Anvil staking is used for the staking of pregrooved bearings to the part by laying over the pregrooved outer lip of the bearing onto the chamfer of the part, as shown in [Figure 9-3](#).

Anvil type staking is used in those applications where a roll staking tool cannot be used (refer to [Table 9-5](#) for the applicable tools.)

1. Anvil stake as follows:



EXTREME CARE MUST BE EXERCISED TO AVOID ANY CONTAMINATION OF BEARING DURING ALL PHASES OF HANDLING AND INSTALLATION.

a. Measure the bore of the part and the outer diameter of a new bearing to make sure dimensions will provide the proper fit given in [Table 9-5](#).

b. Apply coating, as specified in [Table 9-5](#), to the outer diameter of the bearing and to the mating bore in the part.

c. While coating is wet, press the bearing into the part with the bearing/sleeve removal and installation tool set ([Figure 9-1](#)). The bearing must be equally centered from each side of the part.

NOTE

Undue forcing of the anvil staking tool into the outer lip of the pregrooved bearing will cause excessive stress and binding of the staked bearing.

The bearing must be centered in the part and staked a same amount on both sides. To meet this requirement, it may be necessary to partially stake one side, stake the opposite side, then reverse bearing back to first side and finish staking.

d. Select the applicable anvil staking tool given in [Table 9-5](#) and anvil stake both sides of the bearing.

e. Examine the bearing for correct installation as follows:

(1) Make sure the gap between the chamfer of the part and the staked lip of the bearing outer race is no more than 0.005 inch (0.127 mm), as shown in [Figure 9-3](#). As required, stake the bearing again.

(2) Make sure there is no movement or looseness of the bearing outer race in the bore of the part.

(3) Make sure the bearing is centered in the part.

f. Clean any excess coating with clean cheesecloth (C-486) moistened with drycleaning solvent (C-304).

g. Examine the bearing for smooth rotation.

h. Proof load the bearing if required ([Table 9-5](#)).

i. If applicable, do a check of the breakout (misalignment), breakaway or rotational (roll) torque of the bearing as follows (refer to [Table 9-5](#) for specific requirements):

(1) Secure a bolt to the bearing inner race with nuts and washers and rotate the race with a torque wrench, or use a spring scale attached to the bolt ([Figure 9-4](#)).

9-11. PROTECTION OF STAKED BEARINGS DURING INSPECTION

MATERIALS REQUIRED

Refer to [Chapter 13](#) for specifications.

NUMBER	NOMENCLATURE
C-217	Peelable Coating
C-304	Drycleaning Solvent
C-486	Cheesecloth

Prior to the fluorescent penetrant inspection or magnetic particle inspection of parts with staked bearings installed, the bearings must be protected with a peelable coating (C-217).

1. Clean the exposed surface of the bearing with clean cheesecloth (C-486) moistened with drycleaning solvent (C-304).

NOTE

Where possible, the peelable coating (C-217) should overlap the bearing outer diameter 0.125 to 0.250 inch (3.175 to 6.350 mm).

2. Apply a peelable coating (C-217) to the exposed surface of the bearing.
3. After inspection and final cleaning of the part, remove the peelable coating (C-217) from the bearing.
4. Examine the bearing for cleanliness and smooth rotation.

9-12. BUSHINGS

9-13. BUSHINGS — REPLACEMENT

SPECIAL TOOLS REQUIRED

NUMBER	NOMENCLATURE
Workaid Item (Figure 9-7)	Bushing Removal and Installation Tool Set

MATERIALS REQUIRED

Refer to [Chapter 13](#) for specifications.

NUMBER	NOMENCLATURE
C-201	Zinc Chromate Primer
C-309	MEK
C-317	Adhesive
C-407	Abrasive Pad
C-486	Cheesecloth

1. Press out an unserviceable bushing with the bushing removal and installation tool set (Figure 9-7), as follows:

- a. Put the bushing over the fabricated support tool.
- b. Press out the bushing with the fabricated pressing tool.
- c. Thoroughly clean adhesive or primer from the bore of the part with MEK (C-309) and an abrasive pad (C-407).

NOTE

Damage must be removed without exceeding the limit of the maximum bore diameter (refer to the wear, damage, and repair limits of the applicable part).

- d. Inspect the bore of the part for damage.

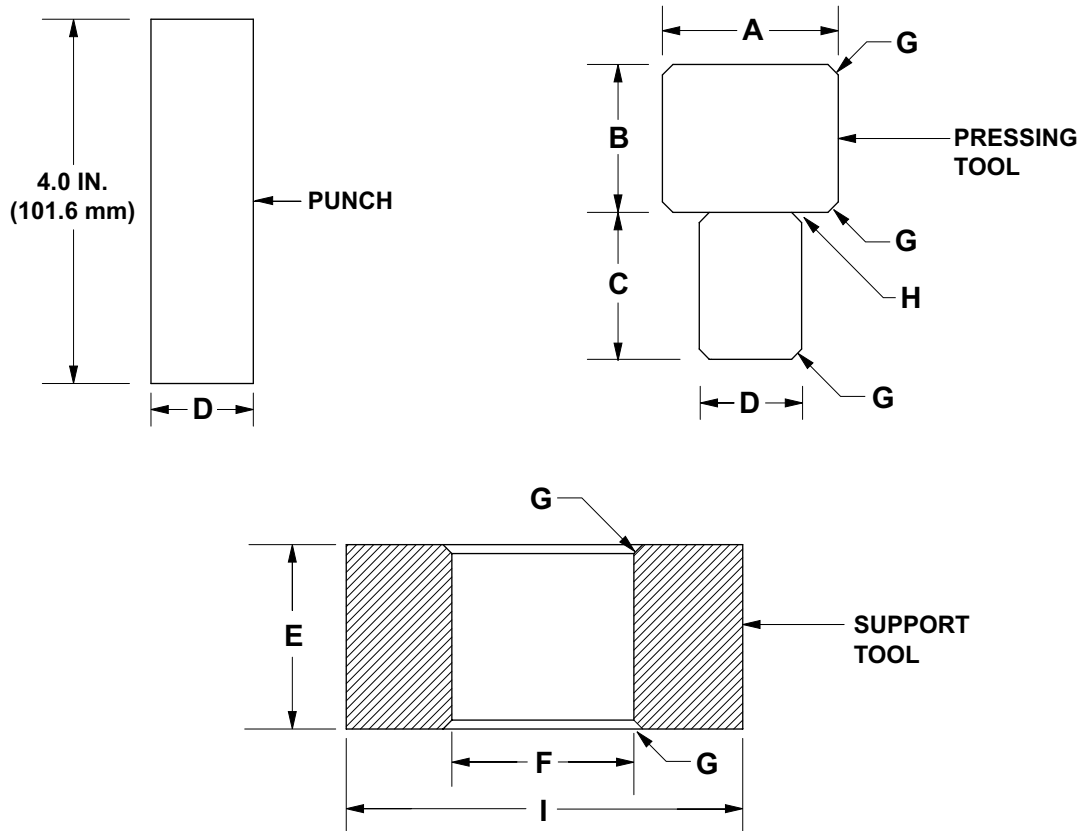

MATERIAL: ANY ALLOY STOCK

NO.	REF LTR	DIMENSIONS
1	A	Slightly smaller than bushing outside diameter.
2	B	Same as bushing length.
3	C	1/2 of bushing length.
4	D	Slightly smaller than bushing inside diameter.
5	E	Slightly longer than bushing length.
6	F	Slightly larger than bushing flange O.D.
7	G	Chamfer 0.025 inch (0.635 mm) by 45°.
8	H	Undercut 0.005 inch (0.127 mm) deep x 0.015 inch (0.381 mm) long.
9	I	Support tool should be large enough to extend ears on either side of lug part to press bushings in or out.

ALL_SPM_09_0007

Figure 9-7. Bushing Removal and Installation Workaids

2. Press a new bushing into the bore of the part with the bushing removal and installation tool set (Figure 9-7), as follows:

a. Clean the new bushing and the bore of the part with clean cheesecloth (C-486) moistened with MEK (C-309). Wipe dry with clean cheesecloth (C-486) before the MEK (C-309) evaporates.

b. As required, apply zinc chromate primer (C-201) or other specified primer, or adhesive (C-317) to the outside diameter of the bushing and the bore of the part.

c. Make sure to install the part on an appropriate support to prevent distortion or stress of the part during pressing.

NOTE

The bushing must have a 0.0005 to 0.0015 inch (0.0127 to 0.0381 mm) interference fit in the bore of the part.

d. Press the bushing into the bore of the part until flush with the part (flanged type bushings) or equally centered from each side (slip type bushings).

e. Clean any excess primer or adhesive with clean cheesecloth (C-486) moistened with MEK (C-309).

f. Allow the zinc chromate primer (C-201) or other specified primer, or the adhesive (C-317) to cure before you ream the bushings. Choose between the following normal and accelerated curing time of the adhesive (C-317):

- Curing time at room temperature: 24 hours at 70 to 90°F (21 to 32°C), or
- Curing time with a heat source: 60 minutes at 170 to 190°F (77 to 88°C).

NOTE

Bushing must be in line and have a surface finished of 63 RHR.

g. As required, ream and countersink the bushings.

9-14. ROD END BEARINGS, INSERTS, AND CLEVIS — REPLACEMENT

MATERIALS REQUIRED

Refer to Chapter 13 for specifications.

NUMBER	NOMENCLATURE
C-309	MEK
C-313	Adhesive
C-317	Adhesive

NOTE

The dimensions that you record must be maintained after repair of the control tube assemblies.

1. Record existing distance between centers of bolt holes, in rod end bearings or clevises, and angle between corresponding faces (Figure 9-8 and Table 9-4).

2. Heat the bonded area of the rod end bearing, clevis, or insert without exceeding the applicable temperature limit:

- Maximum of 212°F (100°C) for aluminum control tubes.
- Maximum of 300°F (149°C) for steel control tubes.

3. Clean the parts as follows:

a. Remove remaining adhesive from the threaded bore of the control tube assembly with a bristle brush and MEK (C-309).

b. Clean the rod end bearing, the clevis, and the insert threads with a bristle brush and MEK (C-309).

c. Rinse the control tube assembly and replacement fitting with MEK (C-309) and allow to air-dry.

NOTE

Unless otherwise specified in notes contained in [Table 9-4](#), adhesive (C-313) is to be used to assemble rod end bearings, clevises, and inserts on aluminum control tubes and adhesive (C-317) is to be used on steel control tubes.

4. Apply adhesive (C-313) or adhesive (C-317), as applicable, to the threads of the rod end bearing or clevis, to the insert and internal threads of the control tube assembly.
5. Install the insert until fully seated in the control tube assembly. Torque the insert to a maximum of 100 inch-pounds (11.30 Nm).
6. Install the rod end bearing or clevis into the control tube assembly.
7. Keep the bead of adhesive in excess to provide for good bonding and sealing.
8. Adjust the distance between centers of bolt holes and the angle between corresponding faces. Refer to

the recorded dimensions and information provided in [Figure 9-8](#) and [Table 9-4](#).

9. Do not touch the rod end bearing, clevis, or insert after you set the length and orientation of the control tube assembly.

NOTE

Do not use heat to cure adhesive (C-313) or adhesive (C-317).

10. Allow adhesive (C-313) or adhesive (C-317) to cure for 24 hours at 75°F (24°C) (full curing time is 5 to 7 days).
11. Do a proof load test of the bonded rod end bearings, clevises, and inserts using the applicable load value:
 - 40 inch-pounds (4.52 Nm) rotational, for 1/4-28 threads.
 - 100 inch-pounds (11.30 Nm) rotational, for 3/8-24 threads.

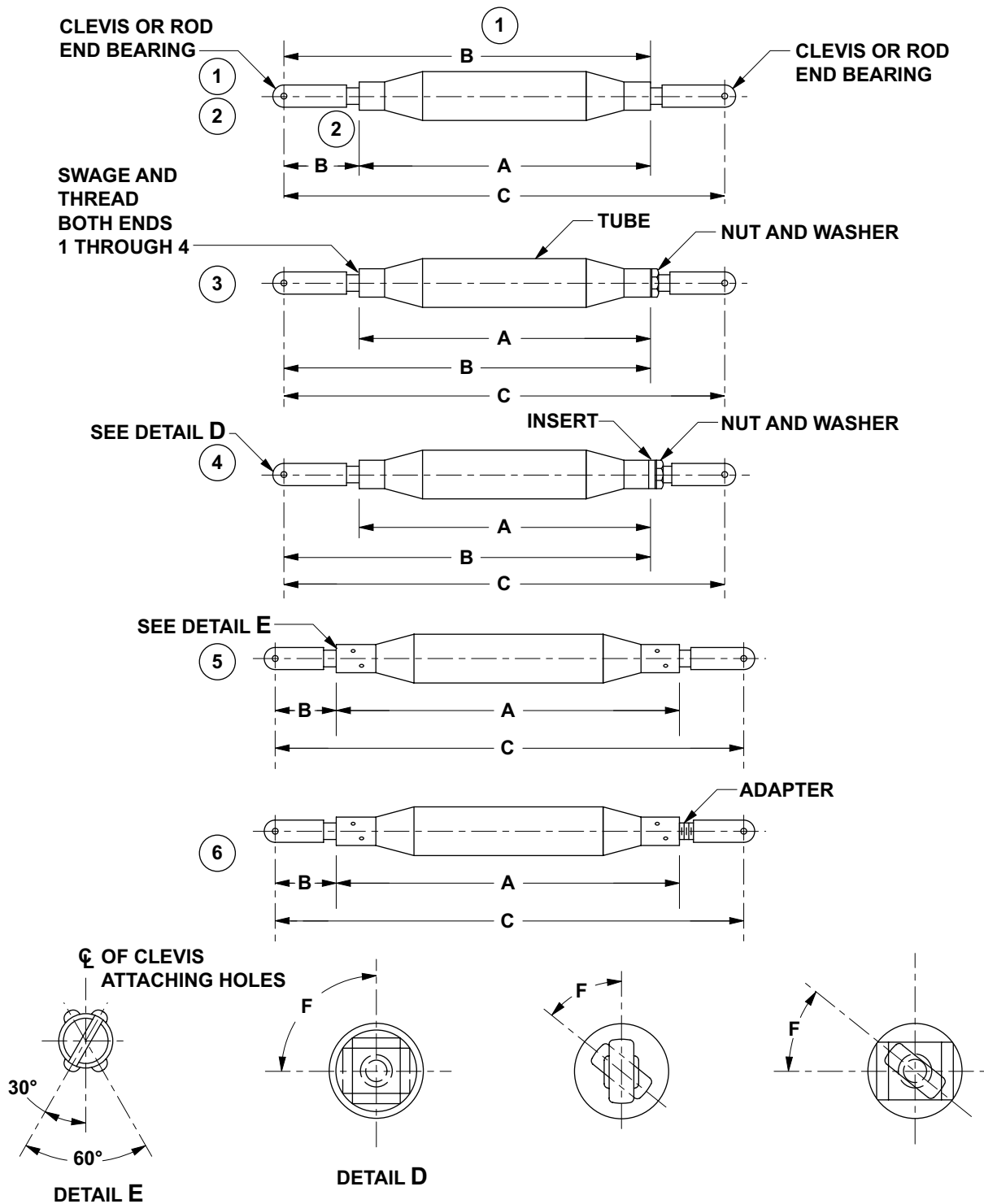

NOTES

1. All dimensions are in Inches. Tolerance ± 0.03 inch (± 0.762 mm).
2. Refer to configuration numbers for assembly dimensions.

ALL_SPM_09_0008

Figure 9-8. Control Tube Assemblies with Bonded or Riveted Clevises, Inserts, or Rod End Bearings

Table 9-4. Control Tube Assemblies

TUBE ASSEMBLY PART NUMBER	DIMENSIONS (INCHES (METRIC))			ANGLE (°)	CONFIGURATION NUMBER	NOTES
	A	B	C	F		
204-001-011-013	8.93 (22.68 cm)	12.24 (0.31 m)	15.55 (0.40 m)	0	5	△ ₁ & DETAIL E
204-001-012-001 (S.I. 212-4)	35.79 (0.91 m)	3.31 (8.41 cm)	44.00 (1.12 m)	–	6	△ ₁₀ & DETAIL E
204-001-012-013 (S.I. 214-4)	7.34 (18.64 cm)	3.31 (8.41 cm)	15.55 (0.40 m)	–	6	△ ₁₀ & DETAIL E
204-001-012-017	7.91 (20.09 cm)	3.31 (8.41 cm)	16.12 (0.41 m)	–	6	△ ₁₀ & DETAIL E
204-001-012-29 (S.I.212-4)	18.46 (0.47 m)	3.31 (8.41 cm)	26.67 (0.68 m)	–	6	△ ₁₀ & DETAIL E
204-001-014-001	20.60 (0.52 m)	0.76 (0.019 mm)	22.12 (0.56 m)	90	5	△ ₉ & DETAIL E
204-001-014-007	20.60 (0.52 m)	0.76 (0.019 mm)	22.12 (0.56 m)	90	5	△ ₉ & DETAIL E
204-001-016-013	9.50 (24.13 cm)	3.31 (8.41 cm)	16.12 (0.41 m)	90	5	△ ₁ & DETAIL E
204-001-027-005	49.70 (01.26 m)	3.31 (8.41 cm)	56.32 (1.43 m)	178-182	5	△ ₁ & DETAIL E
204-001-027-023	43.72 (01.11 m)	3.31 (8.41 m)	50.34 (1.28 m)	178-182	5	△ ₁ & DETAIL E
204-001-047-001	–	–	7.92 (20.12 m)	–	–	△ ₁₁ & DETAIL E
204-001-957-001	3.59 (9.12 cm)	–	10.21 (25.93 cm)	0	5	△ ₁ & DETAIL E
204-010-925-009	14.02 (3.56 m)	14.70 (3.73 m)	17.18 (4.36 m)	–	–	△ ₉ & DETAIL E
204-060-719-037	25.81 (0.66 m)	0.62 (0.016 mm)	27.05 (0.69 m)	0	5	△ ₂₄ & DETAIL E
204-060-719-039	16.46 (0.42 m)	0.62 (0.016 mm)	17.70 (0.45 m)	0	5	△ ₂₄ & DETAIL E
204-060-719-041	34.01(0.86 m)	0.62 (0.016 mm)	35.25 (0.90 m)	0	5	△ ₂₄ & DETAIL E
204-060-719-043	16.70 (0.42 m)	0.62 (0.016 mm)	7.94 (0.46m)	0	5	△ ₂₄ & DETAIL E
204-060-719-045	25.81 (0.66 m)	0.62 (0.016 mm)	27.05 (0.69 m)	0	5	△ ₂₄ & DETAIL E
204-060-719-047	18.60 (0.47 m)	0.62 (0.016 mm)	19.92 (0.51 m)	0	5	△ ₂₄ & DETAIL E

Table 9-4. Control Tube Assemblies (Cont)























TUBE ASSEMBLY PART NUMBER	DIMENSIONS (INCHES (METRIC))			ANGLE (°)	CONFIGURATION NUMBER	NOTES
	A	B	C	F		
204-060-753-025	20.19 (0.51 m)	0.62 (0.016 mm)	22.09 (0.56 m)	0	5	 & DETAIL E
204-060-753-027	31.12 (1.79 m)	0.62 (0.016 mm)	33.37 (0.85 m)	0	5	 & DETAIL E
204-060-792-009	–	1.81 (0.60 cm)	11.40 (28.96 cm)	–	6	
204-061-716-001	23.89 (0.61 m)	24.48 (0.62 m)	25.73 (0.65 m)	–	3	
204-061-716-007	19.57 (0.50 m)	20.16 (90.51 m)	21.41 (0.54 m)	–	3	
205-001-011-001	56.27 (1.43 m)	3.31 (8.41 cm)	62.89 (1.60 m)	0	5	 & DETAIL E
205-001-011-005	47.31 (1.20 m)	3.31 (8.41 cm)	53.93 (1.37 m)	65-69	5	 & DETAIL E
205-001-011-009	51.41 (1.31 m)	3.31 (8.41 cm)	53.03 (1.48 m)	21-25	5	 & DETAIL E
205-011-017-001	23.39 (0.61 m)	1.76 (4.47 cm)	30.05 (0.76 m)	–	6	 & DETAIL E
205-001-017-007	36.29 (0.922 m)	1.76 (4.47 cm)	42.95 (1.09 m)	–	6	 & DETAIL E
205-001-018-005	49.48 (1.26 m)	3.31 (8.41 cm)	56.10 (1.43 m)	0	5	 & DETAIL E
205-001-033-001	5.25 (13.34 cm)	3.31 (8.41 cm)	9.94 (25.25 cm)	0	5	 & DETAIL E
205-060-107-001	17.61 (0.45 m)	0.75 (0.019 mm)	19.07 (0.48 m)	0	5	
205-060-702-001	35.16 (0.89 m)	1.28 (3.25 cm)	37.68 (0.96 m)	0	5	 & DETAIL E
205-060-712-001	–	1.81 (4.60 cm)	20.47 (0.52 m)	–	6	
205-060-729-019	36.65 (0.93 m)	0.62 (0.016 mm)	37.90 (0.96 m)	0	5	 & DETAIL E
205-060-729-021	23.91 (0.61 m)	0.62 (0.016 mm)	25.16 (0.64 m)	0	5	 & DETAIL E
205-060-729-023	22.76 (0.58 m)	0.62 (0.016 mm)	24.02 (0.61 m)	0	5	 & DETAIL E
205-060-729-025	32.32 (0.82 m)	0.62 (0.016 mm)	33.57 (0.85 m)	0	5	 & DETAIL E
205-060-733-009	–	1.81 (4.60 cm)	11.17 (28.37 cm)	–	6	
205-060-734-009	12.70 (0.323 m)	0.62 (0.016 mm)	13.95 (0.35 m)	0	5	 & DETAIL E
205-060-734-011	20.06 (0.51 m)	0.62 (0.016 mm)	21.31 (0.54 m)	0	5	 & DETAIL E

Table 9-4. Control Tube Assemblies (Cont)

TUBE ASSEMBLY PART NUMBER	DIMENSIONS (INCHES (METRIC))			ANGLE (°)	CONFIGURATION NUMBER	NOTES
	A	B	C	F		
206-001-020-029	46.60 (1.18 m)	47.29 (1.20 m)	47.99 (1.22 m)	0	1	7
206-001-020-033	38.82 (0.99 m)	39.51 (1.00 m)	40.20 (1.02 m)	142	1	7
206-001-020-049	9.53 (24.21 cm)	10.26 (26.06 cm)	10.99 (27.91 cm)	5	1	7
206-001-020-067 (Dual Controls Kit)	11.18 (28.40 cm)	11.91 (30.25 cm)	12.65 (0.32 m)	175	1	7
206-001-020-075	28.66 (0.73 m)	29.35 (0.75 m)	30.04 (0.76 m)	0	1	7
206-001-020-101	9.77 (24.82 cm)	10.50 (25.67 cm)	11.23 (28.52 cm)	5	1	7
206-001-021-013	167.27 (4.25 m)	167.96 (4.27 m)	168.65 (4.29 m)	90	1	1
206-001-021-021	167.27 (4.25 m)	167.96 (4.27 m)	168.65 (4.29 m)	90	1	1
206-001-021-017	156.84 (3.99 m)	157.53 (3.99 m)	158.22 (4.02 m)	90	1	7
206-001-022-073	43.79 (1.11 m)	44.48 (1.23 m)	45.86 (1.18 m)	–	3	6
206-001-022-085	13.75 (0.35 m)	14.44 (0.37 m)	15.82 (0.40 m)	–	3	6
206-001-032-001	18.63 (0.47 m)	19.43 (0.49 m)	20.23 (0.51 m)	0	1	7
206-001-058-101	167.27 (4.25 m)	167.96 (4.90 m)	168.65 (4.29 m)	90	1	7
206-001-059-101	157.86 (3.99 m)	157.55 (4.00 m)	158.22 (4.02 m)	90	1	7
206-001-088-001	47.00 (1.19 m)	47.69 (1.21 m)	48.38 (1.23 m)	0	1	7
206-001-089-001	63.80 (1.62 m)	64.50 (1.64 m)	65.20 (1.66 m)	33	1	7
206-001-089-009	63.34 (1.61 m)	64.03 (1.63 m)	64.72 (1.68 m)	11°40	1	7
206-001-096-001	46.03 (1.17 m)	46.72 (1.19 m)	48.04 (1.22 m)	–	4	18
206-001-096-007	41.90 (1.06 m)	42.59 (1.08 m)	43.91 (1.12 m)	–	4	18
206-001-096-013	30.51 (0.78 m)	31.20 (0.79 m)	32.52 (0.83 m)	–	4	18
206-001-096-031	52.75 (1.34 m)	53.44 (1.36 m)	54.90 (1.40 m)	–	4	18

Table 9-4. Control Tube Assemblies (Cont)























TUBE ASSEMBLY PART NUMBER	DIMENSIONS (INCHES (METRIC))			ANGLE (°)	CONFIGURATION NUMBER	NOTES
	A	B	C	F		
206-001-096-037	46.03 (1.17 m)	46.72 (1.19 m)	48.04 (1.22 m)	–	4	 18
206-001-096-043	41.90 (1.06 m)	42.59 (1.08 m)	43.91 (1.12 m)	–	4	 18
206-001-096-113	–	29.82 (0.76 m)	31.14 (0.79 m)	–	4	 18
206-001-097-007	51.21 (1.30 m)	51.96 (1.32 m)	53.45 (1.36 m)	–	4	 18
206-001-097-101	50.12 (1.27 m)	50.87 (1.29 m)	52.36 (1.33 m)	–	4	 18
206-001-098-001	14.60 (0.37 m)	16.32 (0.41 m)	17.82 (0.45 m)	–	4	 20
206-001-099-001	9.08 (23.06 cm)	11.17 (28.37 cm)	14.10 (0.36 m)	–	4	 18
206-001-189-001	5.03 (12.78 cm)	7.12 (18.08 cm)	10.04 (25.50 cm)	–	4	 18
206-001-190-001	6.80 (17.27 cm)	8.89 (22.58 cm)	11.82 (30.02 cm)	–	4	 18
206-001-191-001	77.44 (1.97 m)	79.12 (2.01 m)	80.63 (2.05 m)	–	4	 18
206-001-192-001	14.90 (0.36 m)	16.19 (0.41 m)	18.28 (0.46 m)	0	1	 4
206-001-193-001	12.07 (0.31 m)	14.16 (0.36 m)	16.26 (0.41 m)	0	1	 4
206-001-194-001	7.20 (18.29 cm)	9.29 (23.60 cm)	11.38 (28.91 cm)	0	1	 4
206-001-194-005	6.32 (16.05 cm)	8.41 (21.36 cm)	10.50 (26.67 cm)	0	1	 4
206-001-558-001	–	–	6.98 (17.73 cm)	–	–	 13
206-001-558-003	–	–	6.98 (17.73 cm)	–	–	 13
206-001-558-101	–	–	6.98 (17.73 cm)	–	–	 13
206-001-558-103	–	–	6.98 (17.73 cm)	–	–	 13
206-011-725-001	–	5.15 (13.08 cm)	6.06 (15.39 cm)	90	3	 20
206-061-745-061	7.90 (20.07 cm)	–	10.85 (27.56 cm)	–	6	 22 & DETAIL
206-062-713-001	36.53 (0.93 m)	37.12 (0.94 m)	38.40 (0.98 m)	–	3	 27 & DETAIL
206-063-703-001	8.19 (20.80 cm)	–	11.14 (28.30 cm)	–	6	 22 & DETAIL

Table 9-4. Control Tube Assemblies (Cont)

























TUBE ASSEMBLY PART NUMBER	DIMENSIONS (INCHES (METRIC))			ANGLE (°)	CONFIGURATION NUMBER	NOTES
	A	B	C	F		
206-063-706-001	5.31 (13.49 cm)	5.90 (14.99 cm)	7.14 (18.14 cm)	–	6	 & DETAIL
206-064-702-001	8.62 (21.89 cm)	–	11.70 (29.72 cm)	–	6	  & DETAIL
206-064-702-101	7.76 (19.71 cm)	–	10.85 (27.56 cm)	–	6	  & DETAIL
212-001-051-001	17.27 (0.44 m)	18.02 (0.46 m)	20.83 (0.53 m)	–	3	
212-001-052-001	104.89 (2.89 m)	107.01 (2.72 m)	109.13 (2.77 m)	75	1	
212-001-052-101	104.89 (2.89 m)	107.01 (2.72 m)	109.13 (2.77 m)	75	1	
212-001-052-005	85.26 (2.17 m)	87.38 (2.22 m)	89.50 (2.27 m)	180	1	
212-001-052-105	85.26 (2.17 m)	87.38 (2.22 m)	89.50 (2.27 m)	180	1	
212-001-053-001	103.75 (2.64 m)	105.81 (2.69 m)	108.54 (2.76 m)	–	3	
212-001-053-101	103.75 (2.64 m)	105.81 (2.69 m)	108.54 (2.76 m)	–	3	
212-001-054-001	21.49 (0.55 m)	23.55 (0.60 m)	25.61 (0.65 m)	180	1	
212-001-054-005	36.64 (0.93 m)	38.70 (0.98 m)	40.76 (1.04 m)	90	1	
212-001-055-001	63.63 (1.62 m)	65.69 (1.67 m)	67.75 (1.72 m)	90	1	
212-001-055-101	63.63 (1.62 m)	65.69 (1.67 m)	67.75 (1.72 m)	90	1	
212-001-056-001	10.07 (25.58 cm)	10.82 (0.28 m)	12.88 (0.33 m)	0	1	
212-001-057-001	26.28 (0.67 m)	28.34 (0.72 m)	31.15 (0.79 m)	–	3	
212-001-060-001	21.07 (0.54 m)	21.82 (0.55 m)	23.20 (0.59 m)	–	3	
212-001-061-001	35.08 (0.89 m)	2.15 (5.46 cm)	38.11 (0.97 m)	0	2	
212-001-062-001	20.23 (0.51 m)	20.83 (0.53 m)	21.48 (0.55 m)	50	1	
212-001-062-003	21.75 (0.55 m)	22.35 (0.57 m)	23.00 (0.58 m)	130	1	
212-001-063-001	17.74 (0.45 m)	18.40 (0.47 m)	20.71 (0.53 m)	130	3	
212-001-063-003	16.23 (0.41 m)	16.89 (0.43 m)	18.60 (0.47 m)	50	3	

Table 9-4. Control Tube Assemblies (Cont)























TUBE ASSEMBLY PART NUMBER	DIMENSIONS (INCHES (METRIC))			ANGLE (°)	CONFIGURATION NUMBER	NOTES
	A	B	C	F		
212-001-252-001	20.99 (0.53 m)	21.74 (0.55 m)	23.20 (0.59 m)	–	4	
212-001-270-001	34.42 (0.87 m)	35.27 (0.90 m)	38.11 (0.97 m)	–	4	
212-001-322-001	17.19 (0.44 m)	17.94 (0.46 m)	20.83 (0.53 m)	–	4	
212-001-755-001	59.97 (1.52 m)	60.80 (1.55 m)	62.89 (1.60 m)	0	1	
212-060-724-003	7.51 (19.08 cm)	8.10 (20.57 cm)	9.34 (23.72 cm)	–	3	
212-060-724-007	38.42 (0.98 m)	39.01 (0.99 m)	40.25 (1.02 m)	–	3	
212-060-724-011	22.54 (0.57 m)	23.13 (0.59 m)	23.72 (0.60 m)	0	1	
212-060-724-013	10.88 (27.64 m)	11.63 (29.54 cm)	12.22 (0.31 m)	0	1	
212-060-724-015	36.41 (0.93 m)	37.00 (0.94 m)	37.59 (0.95 m)	0	1	
212-060-724-017	35.31 (0.90 m)	35.90 (0.91 m)	36.49 (0.93 m)	0	1	
212-060-724-019	31.01 (0.79 m)	31.60 (0.80m)	32.19 (0.82 m)	0	1	
212-060-724-021	23.85 (0.61 m)	24.44 (0.62 m)	25.68 (0.65 m)	90	3	
212-060-724-025	25.11 (0.64 m)	25.70 (0.65 m)	26.94 (0.68 m)	90	3	
212-060-724-029	41.47 (1.05 m)	42.06 (1.07 m)	42.65 (1.08 m)	0	1	
212-060-724-031	41.53 (1.06 m)	42.12 (1.07 m)	42.71 (1.09 m)	0	1	
212-060-724-033	26.85 (0.73 m)	27.44 (0.70 m)	28.68 (0.68 m)	–	3	
212-060-724-037	23.20 (0.59 m)	23.79 (0.60 m)	25.03 (0.64 m)	–	3	
212-060-724-041	16.16 (0.41 m)	16.75 (0.43 m)	17.34 (0.44 m)	0	1	
212-060-724-043	37.92 (0.96 m)	38.51 (0.98 m)	39.75 (1.01 m)	–	3	
212-060-724-101	40.87 (1.04 m)	41.46 (1.05 m)	42.05 (1.07 m)	0	1	
212-060-724-105	38.29 (0.97 m)	38.88 (0.99 m)	40.12 (1.02 m)	–	3	
212-060-724-109	38.29 (0.97 m)	39.01 (0.99 m)	40.25 (1.02 m)	–	3	

Table 9-4. Control Tube Assemblies (Cont)























TUBE ASSEMBLY PART NUMBER	DIMENSIONS (INCHES (METRIC))			ANGLE (°)	CONFIGURATION NUMBER	NOTES
	A	B	C	F		
212-076-151-001	26.66 (0.68 m)	28.02 (0.71 m)	31.00 (0.79 m)	–	4	
212-076-151-003	21.09 (0.54 m)	22.39 (0.59 m)	25.43 (0.75 m)	0	4	
212-076-151-007	26.48 (0.67 m)	28.02 (0.71 m)	31.00 (0.65 m)	–	4	
212-076-151-009	20.91 (0.53 m)	22.39 (0.57 m)	25.43 (0.65 m)	–	4	
212-076-151-101	–	23.14 (0.59 m)	26.18 (0.66 m)	90	3	
214-001-020-001	39.25 (1.00 m)	41.31 (1.05 m)	44.00 (1.12 m)	–	4	
214-001-020-013	21.92 (0.56 m)	23.98 (0.61 m)	26.67 (0.68 m)	–	4	
214-001-020-101	21.80 (0.55 m)	23.89 (0.61 m)	26.67 (0.68 m)	–	4	
214-001-020-107	11.25 (28.58 cm)	13.34 (0.34 m)	16.12 (04.1 m)	–	4	
214-001-020-113	39.13 (0.99 m)	41.22 (1.05 m)	44.00 (1.12 m)	–	4	
214-001-020-119	17.67 (0.45 m)	19.76 (0.50 m)	22.54 (0.57 m)	–	4	
214-001-020-125	35.77 (0.91 m)	37.86 (0.96 m)	40.64 (1.03 m)	–	4	
214-001-022-001	27.98 (0.71 m)	29.72 (0.76 m)	32.45 (0.82 m)	90	4	
214-001-022-101	27.58 (0.70 m)	29.32 (0.75 m)	31.93 (0.81 m)	90	4	
214-001-023-001	27.32 (0.69 m)	28.25 (0.72 m)	30.98 (0.79 m)	–	4	
214-001-023-007	24.16 (0.61 m)	25.09 (0.64 m)	27.82 (0.71 m)	–	4	
214-001-023-101	26.82 (0.68 m)	27.75 (0.71 m)	30.48 (0.77 m)	–	4	
214-001-026-007	122.62 (3.12 m)	123.55 (3.14 m)	126.30(3.21 m)	–	4	
214-001-026-107	134.87 (3.43 m)	135.80 (3.45 m)	138.55 (3.52 m)	–	4	
214-001-040-001	22.67 (0.58 m)	24.76 (0.63 m)	27.55 (0.70 m)	–	4	
214-001-041-001	73.18 (1.86 m)	75.27 (1.91 m)	78.06 (1.98 m)	–	4	
214-001-042-001	38.68 (0.98 m)	40.38 (1.03 m)	41.03 (1.04 m)	0	1	 

Table 9-4. Control Tube Assemblies (Cont)

TUBE ASSEMBLY PART NUMBER	DIMENSIONS (INCHES (METRIC))			ANGLE (°)	CONFIGURATION NUMBER	NOTES
	A	B	C	F		
214-001-046-001	41.71 (1.06 m)	43.41 (1.10 m)	45.51 (1.16 m)	90	1	△ ₄
214-001-088-001	24.28 (0.62 m)	26.34 (0.67 m)	28.40 (0.72 m)	0	1	△ ₄
214-001-088-005	39.15 (1.00 m)	41.21 (1.05 m)	43.27 (1.10 m)	90	1	△ ₄
214-001-088-009	8.89 (22.58 cm)	10.95 (27.81 cm)	13.01 (0.33 m)	90	1	△ ₄
214-001-088-013	17.08 (0.43 m)	19.14 (0.49 m)	21.20 (0.54 m)	0	1	△ ₄
214-001-088-017	35.66 (0.91 m)	37.72 (0.96 m)	39.78 (1.01 m)	0	1	△ ₄
214-001-088-021	37.33 (0.95 m)	39.39 (1.00 m)	41.45 (1.05 m)	0	1	△ ₄
214-001-088-025	38.74 (0.98 m)	40.80 (1.04 m)	42.86 (1.09 m)	90	1	△ ₄
214-001-088-101	41.01 (1.04 m)	43.07 (1.09 m)	45.13 (1.15 m)	90	1	△ ₄
214-001-088-105	27.74 (0.71 m)	29.80 (0.76 m)	31.86 (0.81 m)	0	1	△ ₄
214-001-088-109	38.73 (0.98 m)	40.79 (1.04 m)	42.85 (1.09 m)	90	1	△ ₄
214-001-088-113	39.81 (1.01 m)	41.87 (1.06 m)	43.93 (1.12 m)	0	1	△ ₄
214-001-088-117	37.89 (0.96 m)	39.95 (1.02 m)	42.01 (1.07 m)	0	1	△ ₄
214-001-088-121	43.65 (1.11 m)	45.71 (1.16 m)	47.77 (1.21 m)	0	1	△ ₄
214-001-088-125	37.10 (0.94 m)	39.16 (1.00 m)	41.22 (1.05 m)	90	1	△ ₄
214-001-088-129	32.47 (0.83 m)	34.53 (0.88 m)	36.59 (0.83 m)	0	1	△ ₄
214-001-089-001	21.87 (0.56 m)	23.56 (0.60 m)	25.26 (0.64 m)	90	1	△ ₄
214-001-090-001	40.90 (1.04 m)	41.71 (1.06 m)	42.52 (1.08 m)	50 RH	1	△ ₇
214-001-090-002	40.90 (1.04 m)	41.71 (1.06 m)	42.52 (1.08 m)	50 LH	1	△ ₇
214-001-097-005	123.50 (3.14 m)	124.36 (3.16 m)	126.44 (3.21 m)	0	1	△ ₅
214-001-098-005	113.73 (2.89 m)	115.79 (2.94 m)	117.85 (3.00 m)	0	1	△ ₄
214-001-098-009	113.73 (2.89 m)	115.79 (2.94 m)	117.85 (3.00 m)	0	1	△ ₄

Table 9-4. Control Tube Assemblies (Cont)



































TUBE ASSEMBLY PART NUMBER	DIMENSIONS (INCHES (METRIC))			ANGLE (°)	CONFIGURATION NUMBER	NOTES
	A	B	C	F		
214-001-098-013	55.26 (1.40 m)	57.32 (1.46 m)	59.38 (1.51 m)	90	1	
214-001-098-101	59.54 (1.51 m)	61.60 (1.57 m)	63.66 (1.62 m)	90	1	
214-001-141-101	41.01 (1.04 m)	43.07 (1.09 m)	45.13 (1.15 m)	90	1	
214-001-252-101	28.37 (0.72 m)	29.51 (0.75 m)	30.65 (0.78 m)	0	1	
214-001-252-103	28.09 (0.71 m)	29.23 (0.74 m)	30.37 (0.77 m)	0	1	
214-001-348-101	–	–	8.67 (22.02 cm)	–	–	
214-001-790-101	4.75 (12.07 cm)	5.56 (14.12 cm)	8.37 (21.26 cm)	–	3	
214-060-726-001	21.80 (0.55 m)	22.39 (0.57 m)	23.64 (0.60 m)	–	3	 
214-060-726-005	10.11 (25.68 cm)	10.70 (27.18 cm)	11.29 (28.68 cm)	0	1	 
214-060-726-007	36.82 (0.94 m)	37.41 (0.95 m)	38.00 (0.97 m)	0	1	 
214-060-726-009	25.89 (0.66 m)	26.48 (0.67 m)	27.07 (0.69 m)	0	1	 
214-060-726-011	23.87 (0.61 m)	24.46 (0.62 m)	25.05 (0.64 m)	0	1	 
214-060-726-013	24.76 (0.63 m)	25.35 (0.64 m)	25.94 (0.66 m)	0	1	 
214-060-726-035	13.14 (0.33 m)	13.73 (0.35 m)	14.97 (0.38 m)	90	3	 
214-060-726-041	20.28 (0.52 m)	21.73 (0.55 m)	22.98 (0.58 m)	90	3	 
214-060-726-045	14.86 (0.38 m)	15.45 (0.39 m)	16.04 (0.41 m)	0	1	 
214-060-726-083	17.61 (0.45 m)	18.20 (0.46 m)	18.79 (0.48 m)	0	1	 
214-060-726-093	11.16 (28.35 cm)	12.00 (0.31 m)	13.25 (0.34 m)		3	 
222-001-006-101	141.97 (3.61 m)	144.06 (3.66 m)	146.15 (3.71 m)	0	1	
222-001-006-103	141.97 (3.61 m)	144.06 (3.66 m)	146.15 (3.71 m)	0	1	
222-001-007-001	4.54 (11.53 cm)	6.63 (16.84 cm)	9.36 (23.77 cm)	90	4	
222-001-007-025	9.62 (24.44 cm)	11.71 (29.74 cm)	14.44 (0.34 m)	–	4	

Table 9-4. Control Tube Assemblies (Cont)























TUBE ASSEMBLY PART NUMBER	DIMENSIONS (INCHES (METRIC))			ANGLE (°)	CONFIGURATION NUMBER	NOTES
	A	B	C	F		
222-001-007-101	45.22 (1.15 m)	473.1 (1.20 m)	50.04 (1.27 m)	–	4	
222-001-007-107	54.15 (1.38 m)	56.24 (1.43 m)	58.97 (1.50 m)	–	4	
222-001-008-001	29.71 (0.76 m)	31.80 (0.81 m)	35.53 (0.88 m)	–	4	
222-001-008-013	32.09 (0.82 m)	34.18 (8.87 m)	36.91 (0.94 m)	–	4	
222-001-012-001	3.83 (9.73 cm)	5.92 (15.04 cm)	8.57 (21.77 m)	90	3	
222-001-015-101	37.83 (0.96 m)	45.83 (1.16 m)	48.72 (1.24 m)	–	4	
222-001-016-101	61.65 (1.57 m)	62.46 (1.59 m)	64.09 (1.63 m)	–	4	
222-001-016-107	18.27 (0.46 m)	19.08 (0.48 m)	20.71 (0.53 m)	–	4	
222-001-016-113	49.61 (1.26 m)	50.42 (1.28 m)	52.05 (1.32 m)	–	4	
222-001-017-101	50.74 (1.29 m)	2.09 (5.31 cm)	53.64 (1.36 m)	4	2	
222-001-017-105	5.50 (13.97 m)	2.09 (5.31 cm)	8.40 (21.34 cm)	90	2	
222-001-017-109	5.32 (13.51 cm)	2.09 (5.31 cm)	8.22 (20.88 cm)	0	2	
222-001-017-113	38.73 (0.98 cm)	2.09 (5.31 cm)	41.63 (1.06 m)	90	2	
222-001-017-117	2.05 (0.51 m)	2.09 (5.31 cm)	22.95 (0.58 m)	0	2	
222-001-017-121	56.75 (1.44 m)	2.09 (5.31 cm)	59.65 (1.52 m)	90	2	
222-001-017-125	22.22 (0.56 m)	2.09 (5.31 cm)	25.12 (0.64 m)	0	2	
222-001-017-129	28.85 (0.73 m)	2.09 (5.31 cm)	31.15 (0.79 m)	0	2	
222-001-018-105	50.46 (1.28 m)	0.81 (2.06 cm)	52.08 (1.32 m)	90	2	
222-001-018-109	14.98 (0.38 m)	0.81 (2.06 cm)	16.60 (0.42 m)	120	2	
222-001-018-113	50.90 (1.29 m)	0.81 (2.06 cm)	52.52 (1.33 m)	90	2	
222-001-018-117	25.78 (0.66 m)	0.81 (2.06 cm)	27.40 (0.70 m)	120	2	
222-001-019-101	34.94 (0.88 m)	2.10 (5.33 cm)	39.04 (0.99 m)	0	2	

Table 9-4. Control Tube Assemblies (Cont)





























TUBE ASSEMBLY PART NUMBER	DIMENSIONS (INCHES (METRIC))			ANGLE (°)	CONFIGURATION NUMBER	NOTES
	A	B	C	F		
222-001-020-101	11.03 (28.02 cm)	0.81 (2.06 cm)	13.94 (0.35 m)	90	2	
222-001-021-101	9.87 (25.07 cm)	10.74 (27.28 cm)	13.62 (0.35 m)	–	4	
222-001-021-107	15.32 (0.39 m)	16.19 (0.41 m)	19.07 (0.48 m)	–	4	
222-001-021-125	10.81 (27.46 cm)	11.68 (29.67 cm)	14.56 (0.37 m)	–	4	
222-001-088-101	158.34 (4.02 m)	2.095 (5.32 cm)	162.53 (4.13 m)	0	2	
222-001-088-107	158.34 (4.02 m)	2.095 (5.32 cm)	162.53 (4.13 m)	0	2	
222-001-088-109	158.34 (4.02 m)	2.095 (5.32 cm)	162.53 (4.13 m)	0	2	
222-001-088-111	158.34 (4.02 m)	2.095 (5.32 cm)	162.53 (4.13 m)	0	2	
222-001-511-101	23.50 (0.60 m)	24.35 (0.62 m)	25.98 (0.66 m)	–	4	
222-060-236-101	11.10 (28.19 cm)	.65 (1.65 cm)	16.34 (0.42 m)	–	6	 & DETAIL
222-060-236-105	9.85 (25.02 cm)	.65 (1.65 cm)	15.06 (0.38 m)	–	6	 & DETAIL
222-060-733-003	13.15 (.033 m)	13.80 (0.35 m)	15.02 (0.38 m)	–	3	 
222-060-733-101	11.53 (29.29 cm)	12.18 (0.31 m)	13.40 (0.34 m)	–	3	 
222-060-760-005	22.69 (0.58 m)	23.34 (0.59 m)	24.56 (0.62 m)	–	3	 
230-060-030-101	6.88 (17.48 cm)	7.61 (19.32 cm)	8.92 (22.30 cm)	–	3	 
230-060-030-103	5.96 (15.14 cm)	6.69 (16.99 cm)	8.00 (20.32 cm)	–	3	 
230-060-718-109	10.57 (26.85 cm)	.65 (1.65 cm)	15.80 (0.40 m)	–	6	 & DETAIL
230-060-719-101	11.97 (30.40 cm)	12.62 (0.32 m)	13.84 (0.35 m)	–	3	 
407-001-026-101	–	174.85 (4.44 m)	175.60 (4.46 m)	90	1	 
412-001-305-101	17.19 (0.44 m)	17.94 (0.46 m)	20.83 (0.53 m)	–	4	
412-001-307-101	11.14 (28.30 cm)	13.23 (0.34 m)	16.12 (0.41 m)	–	4	





Table 9-4. Control Tube Assemblies (Cont)

NOTES:

- 1 Riveted and bonded clevises both ends.
- 2 Bonded rod end bearing one end, adjustable clevis opposite end.
- 3 Bonded clevis one end, adjustable clevis opposite end.
- 4 Bonded clevises both ends.
- 5 Bonded rod end bearing one end, bonded clevis opposite end.
- 6 Bonded rod end bearing one end, adjustable rod end bearing opposite end.
- 7 Bonded rod end bearings both ends.
- 8 Riveted and bonded rod end bearing one end, riveted and bonded clevis opposite end.
- 9 Riveted and bonded rod end bearings both ends.
- 10 Riveted and bonded clevis one end, riveted and bonded adapter and adjustable clevis, opposite end.
- 11 Riveted clevis on special adapter.
- 12 Riveted and bonded clevis one end, adjustable clevis opposite end.
- 13 Adjustable clevis one end, fixed clevis opposite end.
- 14 Bonded rod end is positioned 115° right of vertical center line when viewing from the bonded rod end.
- 15 Bonded clevis one end, adjustable rod end bearing opposite end.
- 16 Uses adhesive (C-317) for clevis/rod end bearing bond to tube assembly.
- 17 On adjustable control tubes this dimension is nominal. Refer to applicable helicopter rigging procedures.
- 18 Bonded or riveted rod end or clevis one end, adjustable rod end or clevis and bonded insert opposite end.
- 19 Bonded rod end one end, bonded and riveted adapter opposite end. Dimension C includes turnbuckle and both rod ends.
- 20 Rivet rod end one end, adjustable rod end, (and or bonded inset) opposite end.
- 21 Dimension C is measured from inboard hole on rod ends or clevis.
- 22 Riveted clevis one end, riveted adapter and adjustable rod end bearing opposite end.
- 23 Bonded rod end bearing one end, riveted clevis opposite end.

Table 9-4. Control Tube Assemblies (Cont)

NOTES: (CONT)

-  Riveted rod end both ends, install with zinc chromate primer (C-201).
 -  Riveted rod end or clevis one end, special fitting opposite end.
 -  Swaged adapters both ends, riveted rod end one end, adjustable rod end opposite end.
 -  Bonded rod end one end, (one rivet required on some assemblies) adjustable rod end opposite end.
-

9-15. ELASTOMERIC BEARINGS

9-16. ELASTOMERIC BEARINGS — GENERAL

1. Elastomeric bearings are used in most transmission, engine, and pylon isolation mounting systems. They are subject to degradation from fatigue, overload, oil or fluid contamination. Other forms of degradation occur from exposure to excessive heat or atmospheric ozone.

a. Fatigue occurs from normal oscillatory loading and usually causes small flex cracks and/or extrusions of small segments of elastomeric material.

b. Overloading results from excessively high loading of the isolation mounts. Excessive landing forces or other conditions that exceed the mounts limitations can cause overloading. Bearings weakened from fatigue or oil contamination will show signs of overloads during normal operating conditions. Overload signs include mechanical damage to housing, large cracks or extrusion of elastomer.

c. Oil, fuel, solvent, and grease contamination is the most damaging to elastomeric bearings and usually is the cause of early isolation mount replacement. Bearings contaminated with these fluids

become swollen, slick, and show signs of debonding and elastomer separating from metal support. Preventive maintenance is the best method to ensure a long life of elastomeric bearings.

d. Excessive heat exposure will cause the bearing elastomer to become brittle and separate at the bond lines between bearing and support.

e. Ozone cracks due to exposure to the atmosphere occurs along the surface of the elastomer, usually perpendicular to the load. These cracks are small and shallow and will not affect the mount or bearing performance.

f. Wax Bloom. Some elastomers use wax to improve ozone protection. During cycling, the wax comes to the surface of bearing, causing a dirty grayish appearance. This is a normal condition.

9-17. ELASTOMERIC BEARINGS — INSPECTION, MAINTENANCE, AND REPAIR

Refer to the applicable Maintenance Manual (MM) and Component Repair & Overhaul (CR&O) manual for inspection, maintenance, repair, and protection from oil contamination.

Table 9-5. Bearing and Sleeve Replacement Data

MODEL	COMPONENT	BEARING P/N AND HOLE (BORE) SIZE FOR BEARING	SLEEVE P/N AND HOLE (BORE) SIZE FOR SLEEVE	TYPE STAKE AND TOOL NUMBER	NOTES
212 214B 214ST 412 205A-1	204-001-042-001 204-001-042-005	MS27643-4/ AN206DSP4 0.9002 to 0.9007 inch (22.8651 to 22.8778 mm)	120-013-4A/ 23S4-4A 1.0285 to 1.0295 inches (26.1239 to 26.1493 mm)	Ring Stake T101873-13	⚠
205A-1	204-001-148	AN206DSP4/ MS27643-4 0.9002 to 0.9007 inch (22.8651 to 22.8778 mm)	120-013-4A/ 23S4-4A 1.0285 to 1.0295 inches (26.1239 to 26.1493 mm)	Ring Stake T101873-13	⚠

Table 9-5. Bearing and Sleeve Replacement Data (Cont)

MODEL	COMPONENT	BEARING P/N AND HOLE (BORE) SIZE FOR BEARING	SLEEVE P/N AND HOLE (BORE) SIZE FOR SLEEVE	TYPE STAKE AND TOOL NUMBER	NOTES
		DW5/ MS27647-5 0.8738 to 0.8743 inch (22.1945 to 22.2072 mm)	120-015-5A/ 23S6-5A 0.9990 to 1.0000 inch (25.3746 to 25.4000 mm)	Ring Stake T101873-11	⚠
		AN206DSP3/ MS27643-3 0.7769 to 0.7774 inch (19.7333 to 19.7460 mm)	120-013-3A/ 23S4-3A 0.9060 to 0.9065 inch (23.0124 to 23.0251 mm)	Ring Stake T101873-5	⚠
205A-1 214B	204-001-178	AN201KP4A/ MS27641-4 0.7488 to 0.7493 inch (19.0195 to 19.0322 mm)	120-012-4A/ 23S3-4A 0.8655 to 0.8665 inch (21.9837 to 22.0091 mm)	Ring Stake T101873-3	⚠
		AN201KP5A/ MS27641-5 0.8113 to 0.8118 inch (20.6070 to 20.6197 mm)	120-012-5A/ 23S3-5A 0.9365 to 0.9375 inch (23.7871 to 23.8125 mm)	Ring Stake T101873-7	⚠
		AN201KP8A/ MS27641-8 1.1238 to 1.1243 inches (28.5445 to 28.5572 mm)	120-012-8A/ 23S3-8A 1.2495 to 1.2500 inches (31.7373 to 31.7500 mm)	Ring Stake T101873-17	⚠
205A-1 212 214B 412	204-001-185	MS27643-4/ AN206DSP4 0.9002 to 0.9007 inch (22.8651 to 22.8778 mm)	120-013-4A/ 23S4-4A 1.0285 to 1.0295 inches (26.2239 to 26.1493 mm)	Ring Stake T101873-13	⚠
205A-1 214B	204-001-195	AN201KP4A/ MS27641-4 0.7488 to 0.7499 inch (19.0195 to 19.0475 mm)	120-012-4A/ 23S3-4A 0.8655 to 0.8665 inch (21.9837 to 22.0091 mm)	Ring Stake T101873-3	⚠

Table 9-5. Bearing and Sleeve Replacement Data (Cont)

MODEL	COMPONENT	BEARING P/N AND HOLE (BORE) SIZE FOR BEARING	SLEEVE P/N AND HOLE (BORE) SIZE FOR SLEEVE	TYPE STAKE AND TOOL NUMBER	NOTES
		AN201KP5A/ MS27641-5 0.8113 to 0.8118 inch (20.6070 to 20.6197 mm)	120-012-5A/ 23S3-5A 0.9365 to 0.9375 inch (23.7871 to 23.8125 mm)	Ring Stake T101873-7	⚠
		AN201KP8A/ MS27641-8 1.1238 to 1.1243 inches (28.5445 to 28.5572 mm)	120-012-8A/ 23S3-8A 1.2495 to 1.2500 inches (31.7373 to 31.7500 mm)	Ring Stake T101873-17	⚠
205A-1 212 412	204-001-332	AN206DSP4/ MS27643-4 0.9002 to 0.9007 inch (22.8651 to 22.8778 mm)	120-013-4A/ 23S4-4A 1.0285 to 1.0295 inches (26.1239 to 26.1493 mm)	Ring Stake T101873-13	⚠
212 214ST	204-001-333	MS27640-5 1.2490 to 1.2495 inches (31.7246 to 31.7373 mm)	204-001-345-001 1.3740 to 1.3745 inches (34.8996 to 34.9123 mm)	Not Staked	⚠
		None	204-001-346-001 3.2310 to 3.2315 inches (82.0674 to 82.0801 mm)	Not Staked	⚠
205A-1 212 214ST	204-001-351	AN206DSP4/ MS27643-4 0.9002 to 0.9007 inch (22.8651 to 22.8778 mm)	120-013-4A 1.0285 to 1.0295 inches (26.1239 to 26.1493 mm)	Ring Stake T101873-13	⚠
205A-1 212 214ST	204-001-352	AN206DSP4/ MS27643-4 0.9002 to 0.9007 inch (22.8651 to 22.8778 mm)	120-013-4A/ 23S4-4A 1.0285 to 1.0295 inches (26.1239 to 26.1493 mm)	Ring Stake T101873-13	⚠

Table 9-5. Bearing and Sleeve Replacement Data (Cont)









MODEL	COMPONENT	BEARING P/N AND HOLE (BORE) SIZE FOR BEARING	SLEEVE P/N AND HOLE (BORE) SIZE FOR SLEEVE	TYPE STAKE AND TOOL NUMBER	NOTES
		DW4K/ MS27647-4/ DW4 0.7488 to 0.7493 inch (19.0195 to 19.0322 mm)	120-015-4KA/ 23S6-4KA 0.8655 to 0.8665 inch (21.9837 to 22.0091 mm)	Ring Stake T101873-3	
205A-1 212 214B 214ST 412	204-001-353	AN200KP4/ MS27640-4 0.9002 to 0.9007 inch (22.8651 to 22.8778 mm)	120-011-4A/ 23S2-4A 1.0285 to 1.0295 inches (26.1239 to 26.1493 mm)	Ring Stake T101873-13	
		AN201KP4A/ MS27641-4 0.7488 to 0.7493 inch (19.0195 to 19.0322 mm)	120-012-4A/ 23S3-4A 0.8655 to 0.8665 inch (21.9837 to 22.0091 mm)	Ring Stake T101873-3	
205A-1 212 214B 214ST 412	204-001-356	AN206DSP4/ MS27643-4 0.9002 to 0.9007 inch (22.8651 to 22.8778 mm)	120-013-4A/ 23S4-4A 1.0285 to 1.0295 inches (26.1239 to 26.1493 mm)	Ring Stake T101873-13	
205A-1 212 214B 214ST 412	204-001-357-001 204-001-357-005	AN206DSP4/ MS27643-4 0.9002 to 0.9007 inch (22.8651 to 22.8778 mm)	120-013-4A/ 23S4-4A 1.0285 to 1.0295 inches (26.1239 to 26.1493 mm)	Ring Stake T101873-13	
204B 205A-1 212	204-001-358 or 212-001-321	AN206DSP4/ MS27643-4 0.9002 to 0.9007 inch (22.8651 to 22.8778 mm)	120-013-4A/ 23S4-4A 1.0285 to 1.0295 inches (26.1239 to 26.1493 mm)	Ring Stake T101873-13	
205A-1 212 214B 214ST 412	204-001-362-001	AN200KP5/ MS27640-5 1.2490 to 1.2495 inches (31.7246 to 31.7373 mm)	204-001-345-1 1.3740 to 1.3745 inches (34.8996 to 34.9123 mm)	None	  (Hole for bushing)

Table 9-5. Bearing and Sleeve Replacement Data (Cont)







MODEL	COMPONENT	BEARING P/N AND HOLE (BORE) SIZE FOR BEARING	SLEEVE P/N AND HOLE (BORE) SIZE FOR SLEEVE	TYPE STAKE AND TOOL NUMBER	NOTES
205A-1 212 214B 412	204-001-514-001	MS27641-4/ AN201KP4A 0.7488 to 0.7493 inch (19.0195 to 19.0322 mm)	120-012-4A/ 23S3-4 0.8660 to 0.8665 inch (21.9964 to 22.0091 mm)	Ring Stake T101873-3	
		None 0.7501 to 0.7505 inch (19.0525 to 19.0627 mm)	120-012-4S/ 23S3-4S 0.8660 to 0.8665 inch (21.9964 to 22.0091 mm)	Ring Stake T101873-3	
205A-1 212	204-001-559	AN206DSP4/ MS27643-4 0.9002 to 0.9007 inch (22.8651 to 22.8778 mm)	120-013-4A/ 23S4-4A 1.0285 to 1.0295 inches (26.1239 to 26.1493 mm)	Ring Stake T101873-13	
205A-1 212 412	204-001-603	AN206DSP4/ MS27643-4 0.9002 to 0.9007 inch (22.8651 to 22.8778 mm)	120-013-4A/ 23S4-4A 1.0285 to 1.0295 inches (26.1239 to 26.1493 mm)	Ring Stake T101873-13	
		MS27647-5 0.8738 to 0.8743 inch (22.1945 to 22.2072 mm)	120-015-5A/ 23S6-5A 0.9990 to 1.0000 inch (25.3756 to 25.4000 mm)	Ring Stake T101873-11	
205A-1 212 214B 214ST 412	204-001-700-001	DW6/ MS27647-6 1.0613 to 1.0618 inches (26.9570 to 26.9697 mm)	120-015-6A/ 23S6-6A 1.1870 to 1.1875 inches (30.1498 to 30.1625 mm)	Ring Stake T101873-15	
205A-1 212 214B 214ST 412	204-001-701-001	AN201KP6A/ MS27641-6 0.8738 to 0.8743 inch (22.1945 to 22.2072 mm)	120-012-6A/ 23S3-6A 0.9990 to 1.0000 inch (25.3746 to 25.4000 mm)	Ring Stake T101873-9	

Table 9-5. Bearing and Sleeve Replacement Data (Cont)





MODEL	COMPONENT	BEARING P/N AND HOLE (BORE) SIZE FOR BEARING	SLEEVE P/N AND HOLE (BORE) SIZE FOR SLEEVE	TYPE STAKE AND TOOL NUMBER	NOTES
212 214ST	204-001-760-001	MS27643-4 0.9002 to 0.9007 inch (22.8651 to 22.8778 mm)	120-013-4A/ 23S4-4A 1.0285 to 1.0295 inches (26.1239 to 26.1493 mm)	Ring Stake T101873-13	
205A-1 212 214B 214ST 412	204-001-809	AN206DSP4/ MS27643-4 0.9002 to 0.9007 inch (22.8651 to 22.8778 mm)	120-013-4A/ 23S4-4A 1.0285 to 1.0295 inches (26.1239 to 26.1493 mm)	Ring Stake T101873-13	
205A-1 212 412	204-001-855-001	AN206DSP4/ MS27643-4 0.9002 to 0.9007 inch (22.8651 to 22.8778 mm)	None	Roll Stake	
		MS27647-4/ DW4 0.7488 to 0.7493 inch (19.0195 to 19.0322 mm)	None	Roll Stake	
205A-1 212 412	204-001-855-101	AN206DSP4/ MS27643-4 0.9002 to 0.9007 inch (22.8651 to 22.8778 mm)	120-013-4A/ 23S4-4A 1.0285 to 1.0295 inches (26.1239 to 26.1493 mm)	Ring Stake T101873-13	
		MS27647-4/ DW4 0.7488 to 0.7493 inch (19.0195 to 19.0322 mm)	120-015-4KA 23S6-4KA 0.8655 to 0.8665 inch (21.0285 to 21.1493 mm)	Ring Stake T101873-3	
205A-1 212	204-001-954	AN201KP5A/ MS27641-5 0.8113 to 0.8118 inch (20.6070 to 20.6197 mm)	120-012-5A/ 23S3-5 0.9365 to 0.9375 inch (23.7871 to 23.8125 mm)	Ring Stake T101873-7	

Table 9-5. Bearing and Sleeve Replacement Data (Cont)

MODEL	COMPONENT	BEARING P/N AND HOLE (BORE) SIZE FOR BEARING	SLEEVE P/N AND HOLE (BORE) SIZE FOR SLEEVE	TYPE STAKE AND TOOL NUMBER	NOTES
212	204-011-128	204-011-118-001 1.0615 to 1.0620 inches (26.9621 to 26.9748 mm)	None	Segment Stake Depth 0.015 to 0.020 inch (0.381 to 0.508 mm)	△ ₁
205A-1	204-011-246	BR5 1.2488 to 1.2493 inches (31.7195 to 31.7322 mm)	120-013-5A/ 23S5-5 1.3745 to 1.3750 inches △ ₅ (34.9123 to 34.9250 mm)	Ring Stake T101873-19	
205A-1	204-011-301	AN201KP6A/ MS27641-6 0.8740 to 0.8745 inch (22.1996 to 22.2123 mm)	204-010-422-3 0.9995 to 1.0005 inches (25.3873 to 25.4127 mm)	None	△ ₁
		BR5R 1.2485 to 1.2490 inches (31.7119 to 31.7246 mm)	120-013-5A/ 23S5-5 1.3745 to 1.3750 inches (34.9123 to 34.9250 mm)	Ring Stake T101873-19	△ ₁
205A-1	204-011-438	AN201KP8A/ MS27641-8A 1.1240 to 1.1245 inches (28.5496 to 28.5623 mm)	204-010-422-13, -19 1.2495 to 1.2510 inches △ ₅ (31.7373 to 31.7754 mm)	Ring Stake T101873-17	
205A-1	204-030-504	MS27645-3A MS27261KSP3L/ 0.6238 to 0.6243 inch (15.8445 to 15.8572 mm)	120-011-3LS 0.7495 to 0.7500 inch (19.0373 to 19.0500 mm)	Ring Stake T101873-95	△ ₁
205A-1	204-030-987	BSSN9003G/ RSS9 1.0932 to 1.0935 in. (27.7673 to 27.7749 mm)	204-030-909-011 1.2182 to 1.2187 in. (30.9423 to 30.9550 mm)	Ring Stake 30118 △ ₆	△ ₁ △ ₄

Table 9-5. Bearing and Sleeve Replacement Data (Cont)









MODEL	COMPONENT	BEARING P/N AND HOLE (BORE) SIZE FOR BEARING	SLEEVE P/N AND HOLE (BORE) SIZE FOR SLEEVE	TYPE STAKE AND TOOL NUMBER	NOTES
212	204-031-244-005	RSS-9 1.0932 to 1.0937 inches (27.7673 to 27.7800 mm)	204-030-909-011 1.2182 to 1.2187 inches (30.9423 to 30.9550 mm)	Ring Stake 30118 	
212	204-031-920-003	LS-4/S-4/ KLS-4 214-030-216-001 0.7488 to 0.7493 inch (19.0195 to 19.0322 mm)	Length as shown in text 120-015-4KA 0.8655 to 0.8665 inch (21.9837 to 22.0091 mm)	Ring Stake T101873-3	
205A-1	204-060-779	AN207DPP3/ MS27644-3 0.7762 to 0.7767 inch (19.7155 to 19.7282 mm)	23S5-3A 0.9060 to 0.9065 inch (23.0124 to 23.0251 mm)	Ring Stake T101873-5	
205A-1	205-001-307	DW5 0.8738 to 0.8743 inch (22.1945 to 22.2072 mm)	None	Anvil or Roll Stake	
		205-001-048-001 209-001-051-001 0.6562 to 0.6567 inch (16.6675 to 16.6802 mm)	None	Anvil or Roll Stake T102095-3	 
205A-1 214B	205-001-704	AN206DSP4/ MS27643-4 0.9002 to 0.9007 inch (22.8651 to 22.8778 mm)	120-013-4A/ 23S4-4A 1.0285 to 1.0295 inches (26.1239 to 26.1493 mm)	Ring Stake T101873-13	
		DW5/ MS27647-5 0.8738 to 0.8743 inch (22.1945 to 22.2072 mm)	23S6-5A/ 120-015-5A 0.9995 to 1.0000 inch (25.3873 to 25.4000 mm)	Ring Stake T101873-11	

Table 9-5. Bearing and Sleeve Replacement Data (Cont)







MODEL	COMPONENT	BEARING P/N AND HOLE (BORE) SIZE FOR BEARING	SLEEVE P/N AND HOLE (BORE) SIZE FOR SLEEVE	TYPE STAKE AND TOOL NUMBER	NOTES
205A-1	205-001-722	209-001-051-001 0.6562 to 0.6567 inch (16.6675 to 16.6802 mm)	None	Anvil or Roll Stake T102095-3	 
		209-001-055-001 0.7488 to 0.7493 inch (19.019 to 19.0322 mm)	None	Anvil or Roll Stake T102095-1	 
205A-1	205-001-734	209-001-051-001 0.6562 to 0.6567 inch (16.6675 to 16.6802 mm)	None	Anvil or Roll Stake T102095-3	 
		209-001-055-001 0.7488 to 0.7493 inch (19.019 to 19.0322 mm)	None	Anvil or Roll Stake T102095-1	
205A-1	205-001-736	209-001-051-001 0.6562 to 0.6567 inch (16.6675 to 16.6802 mm)	None	Anvil or Roll Stake T102095-3	 
		209-001-055-001 0.7488 to 0.7493 inch (19.019 to 19.0322 mm)	None	Anvil or Roll Stake T102095-1	 
205A-1	205-001-773	209-001-051-001 0.6562 to 0.6567 inch (16.6675 to 16.6802 mm)	None	Anvil or Roll Stake T102095-3	
		MS27643-4 0.9002 to 0.9007 inch (22.8651 to 22.8778 mm)	120-013-4A 1.0285 to 1.0295 inches (26.1239 to 26.1493 mm)	Ring Stake T101873-13	

Table 9-5. Bearing and Sleeve Replacement Data (Cont)













MODEL	COMPONENT	BEARING P/N AND HOLE (BORE) SIZE FOR BEARING	SLEEVE P/N AND HOLE (BORE) SIZE FOR SLEEVE	TYPE STAKE AND TOOL NUMBER	NOTES
		MS27647-5 0.8738 to 0.8743 inch (22.1945 to 22.2072 mm)	23S6-5A/ 120-015-5A 0.9995 to 1.0000 inch (25.3873 to 25.4000 mm)	Ring Stake T101873-11	
205A-1	205-001-902	LHVA-5-26 RALT-5-4 76569 LHRA-5-26 ATSB5AA2 1.2500 to 1.2505 inches (31.7500 to 31.7627 mm)	120-013-5A 1.3740 to 1.3750 inches (34.8996 to 34.9250 mm)	Ring Stake T101873-19	 
212	205-001-905	AN206DSP4 MS27643-4 0.9002 to 0.9007 inch (22.8651 to 22.8778 mm)	120-013-4A/ 23S4-4A 1.0285 to 1.0295 inches (26.1239 to 26.1493 mm)	Ring Stake T101873-13	 
		AN206DSP5 MS27643-5 1.2488 to 1.2493 inches (31.7195 to 31.7322 mm)	120-013-5A/ 23S4-5A 1.3745 to 1.3750 inches (34.9123 to 34.9250 mm)	Ring Stake T101873-19	 
		DW5 0.8738 to 0.8743 inch (22.1945 to 22.2072 mm)	23S6-5A/ 120-015-5A 0.9995 to 1.0000 inch (25.3873 to 25.4000 mm)	Ring Stake T101873-11	 
205A-1	205-001-908-005	209-001-051-001 0.6562 to 0.6567 inch (16.6675 to 16.6802 mm)	None	Anvil or Roll Stake T102095-3	 
		209-001-055-001 0.7488 to 0.7493 inch (19.019 to 19.0322 mm)	None	Anvil or Roll Stake T102095-1	 

Table 9-5. Bearing and Sleeve Replacement Data (Cont)

MODEL	COMPONENT	BEARING P/N AND HOLE (BORE) SIZE FOR BEARING	SLEEVE P/N AND HOLE (BORE) SIZE FOR SLEEVE	TYPE STAKE AND TOOL NUMBER	NOTES
205A-1 212 412	205-001-914-001 205-001-914-029 205-001-914-103	MS27643-4 0.9002 to 0.9007 inch (22.8651 to 22.8778 mm)	120-013-4A/ 23S4-4A 1.0290 to 1.0295 inches (26.1366 to 26.1493 mm)	Ring Stake T101873-13	
412	205-001-914-027 205-001-914-107	206-010-470-101 0.9375 to 0.9380 inch (23.8125 to 23.8252 mm)	None	Roll stake T101530-3 or RST2012	
205A-1	205-001-916	209-001-051-001 0.6562 to 0.6567 inch (16.6675 to 16.6802 mm)	None	Anvil or Roll Stake T102095-3	
		209-001-055-001 0.7488 to 0.7493 inch (19.019 to 19.0322 mm)	None	Anvil or Roll Stake T102095-1	
205A-1	205-001-917	MDW5 0.8738 to 0.8743 inch (22.1945 to 22.2072 mm)			
		209-001-051-001 0.6562 to 0.6567 inch (16.6675 to 16.6802 mm)	None	Anvil or Roll Stake T102095-3	
205A-1	205-001-919	MWD4 0.8738 to 0.8743 inch (22.1945 to 22.2072 mm)			
		209-001-051-001 0.6562 to 0.6567 inch (16.6675 to 16.6802 mm)	None	Anvil or Roll Stake T102095-3	

Table 9-5. Bearing and Sleeve Replacement Data (Cont)













MODEL	COMPONENT	BEARING P/N AND HOLE (BORE) SIZE FOR BEARING	SLEEVE P/N AND HOLE (BORE) SIZE FOR SLEEVE	TYPE STAKE AND TOOL NUMBER	NOTES
		206-010-469-001/ 206-010-470-101 0.9375 to 0.9380 inch (23.8125 to 23.8252 mm)	None	Roll Stake T101530-3 RST2010 	
205A-1	205-001-921	209-001-055-001 0.7488 to 0.7493 inch (19.0195 to 19.0322 mm)	None	Anvil or Roll Stake T102095-1	 
		209-001-051-001 0.6562 to 0.6567 inch (16.6675 to 16.6802 mm)	None	Anvil or Roll Stake T102095-3	 
205A-1	205-030-323	RG9SS/ 12-2-0-00-09/ MS14101-9 1.0932 to 1.0937 inches (27.7673 to 27.7800 mm)	None	Roll Stake RT-101-9 	 
205A-1	205-032-124	209-001-051-001 0.6562 to 0.6567 inch (16.6675 to 16.6802 mm)	None	Anvil or Roll Stake T102095-3	
205A-1	205-060-717	MS20200KP4 0.9002 to 0.9007 inch (22.8651 to 22.8778 mm)	120-011-4A 1.0285 to 1.0295 inches (26.1239 to 26.1493 mm)	Ring Stake T101873-13	
205A-1	205-060-718	MS20200KP4 0.9002 to 0.9007 inch (22.8651 to 22.8778 mm)	120-011-4A 1.0285 to 1.0295 inches (26.1239 to 26.1493 mm)	Ring Stake T101873-13	
205A-1 214B	205-060-719	MS20200KP4 0.9002 to 0.9007 inch (22.8651 to 22.8778 mm)	120-011-4A 1.0285 to 1.0295 inches (26.1239 to 26.1493 mm)	Ring Stake T101873-13	

Table 9-5. Bearing and Sleeve Replacement Data (Cont)

MODEL	COMPONENT	BEARING P/N AND HOLE (BORE) SIZE FOR BEARING	SLEEVE P/N AND HOLE (BORE) SIZE FOR SLEEVE	TYPE STAKE AND TOOL NUMBER	NOTES
205A-1	205-060-720	MS20200KP4 0.9002 to 0.9007 inch (22.8651 to 22.8778 mm)	120-011-4A 1.0285 to 1.0295 inches (26.1239 to 26.1493 mm)	Ring Stake T101873-13	△ ₄
205A-1	205-076-381-005	RDW-5T-3V-1 0.8740 to 0.8745 inch (22.1996 to 22.2123 mm)	None	Roll Stake T101886-1 or RST2020 △ ₇	△ ₁ △ ₄ △ ₉
206L/ L1/L3	206-001-074	209-001-051-001 0.6562 to 0.6567 inch (16.6675 to 16.6802 mm)	None	Anvil Stake T102095-3	△ ₁ △ ₄
206A/B 206L/ L1/L3/ L4	206-001-139	206-001-053-005 0.9062 to 0.9067 inch (23.0175 to 23.0302 mm)	None	Not Staked	△ ₁
206A/B 206L/ L1/L3/ L4	206-001-140	206-001-053-005 0.9062 to 0.9067 inch (23.0175 to 23.0302 mm)	None	Not Staked	△ ₁
206A/B	206-001-339-023 or 206-001-339-033	206-001-053-005 0.9062 to 0.9067 inch (23.0175 to 23.0302 mm)	None	Roll Stake T101530-3 or RST2012 △ ₇	△ ₁ △ ₂ △ ₄
		MS20200KP4 0.9002 to 0.9007 inch (22.8651 to 22.8778 mm)	None	Not Staked	△ ₁₂ △ ₃₁
206A/B 206L/ L1/L3	206-001-400-005 or 206-001-400-009	206-001-053-005/ 209-001-051-101 0.9062 to 0.9067 inch (23.0175 to 23.0302 mm)	None	Roll Stake T101530-3 or RST2012 △ ₇	△ ₁ △ ₄ △ ₂₉

Table 9-5. Bearing and Sleeve Replacement Data (Cont)



















MODEL	COMPONENT	BEARING P/N AND HOLE (BORE) SIZE FOR BEARING	SLEEVE P/N AND HOLE (BORE) SIZE FOR SLEEVE	TYPE STAKE AND TOOL NUMBER	NOTES
206A/B 206L/ L1/L3/ L4	206-001-401	206-001-053-005/ 209-001-051-101 0.9062 to 0.9067 inch (23.0175 to 23.0302 mm)	None	Roll Stake T101530-3 or RST2012 	  
206A/B	206-001-520	MS20201KP4A/ MS27641-4 0.7488 to 0.7493 inch (19.0195 to 19.0322 mm)	120-012-4A 0.8660 to 0.8665 inch (21.9964 to 22.0091 mm)	Ring Stake T101873-3	 
		None	120-012-4S 0.8660 to 0.8665 inch (21.9964 to 22.0091 mm) 0.7501 to 0.7505 inch (I.D.) (19.0525 to 19.0627 mm)	Ring Stake T101873-3	  
206A/B 206B3	206-001-526	206-010-469-001/ 206-010-470-101 0.9375 to 0.9380 inch (23.8125 to 23.8252 mm)	None	Roll Stake T101530-3 or RST2012 	  
206A/B 206B3	206-001-538	206-001-053-005 0.9062 to 0.9067 inch (23.0175 to 23.0302 mm)	None	Roll Stake T101530-3 or RST2012 	  
206L/ L1/L3/ L4	206-001-547-005 or 206-001-547-006	MS27641-4 0.7500 to 0.7505 inch (19.0500 to 19.0627 mm)	None	Not Staked	
206L/ L1/L3/ L4	206-001-549	MS27647-5 0.8738 to 0.8743 inch (22.1945 to 22.2072 mm)	120-015-5A 0.999 to 1.000 inch (25.3746 to 25.4000 mm)	Ring Stake T101873-11	

Table 9-5. Bearing and Sleeve Replacement Data (Cont)



















MODEL	COMPONENT	BEARING P/N AND HOLE (BORE) SIZE FOR BEARING	SLEEVE P/N AND HOLE (BORE) SIZE FOR SLEEVE	TYPE STAKE AND TOOL NUMBER	NOTES
206L/ L1/L3/ L4	206-001-550	MS27647-5 0.8738 to 0.8743 inch (22.1945 to 22.2072 mm)	120-015-5A 0.999 to 1.000 inch (25.3746 to 25.4000 mm)	Ring Stake T101873-11	 
		MS14103-3 0.6239 to 0.6244 inch (15.8471 to 15.8598 mm)	None	Roll Stake RST1001 	 
206L/ L1/L3/ L4	206-001-551	MS27647-6 1.0613 to 1.0618 inches (26.9570 to 26.9697 mm)	120-015-6A 1.1865 to 1.1875 inches (30.1371 to 30.1625 mm)	Ring Stake T101873-15	 
		206-010-469-001/ 206-010-470-101 0.9375 to 0.9380 inch (23.8125 to 23.8252 mm)	None	Roll Stake T101530-3 or RST2012 	  
206L/ L1/L3/ L4	206-001-552	206-001-053-005 0.9062 to 0.9067 inch (23.0175 to 23.0302 mm)	None	Roll Stake T101530-3 or RST2012 	  
206L/ L1/L3/ L4 407 427	206-001-556	MS27645-4A 0.7488 to 0.7493 inch (19.0195 to 19.0322 mm)	120-012-4A 0.8660 to 0.8665 inch (21.9964 to 22.0091 mm)	Ring Stake T101873-3	 
206L/ L1	206-001-560	MS27641-4 0.7488 to 0.7493 inch (19.0195 to 19.0322 mm)	120-012-4A 0.8660 to 0.8665 inch (21.9964 to 22.0091 mm)	Ring Stake T101873-3	 

Table 9-5. Bearing and Sleeve Replacement Data (Cont)











MODEL	COMPONENT	BEARING P/N AND HOLE (BORE) SIZE FOR BEARING	SLEEVE P/N AND HOLE (BORE) SIZE FOR SLEEVE	TYPE STAKE AND TOOL NUMBER	NOTES
		None	120-012-4S 0.8660 to 0.8665 inch (21.9964 to 22.0091 mm) 0.7501 to 0.7505 inch (I.D.) (19.0525 to 19.0627 mm)		
		MS27641-5 0.8113 to 0.8118 inch (20.6070 to 20.6197 mm)	120-012-5A 0.9365 to 0.9375 inch (23.7871 to 23.8125 mm)	Ring Stake T101873-7	 
		None	120-012-5S 0.9365 to 0.9375 inch (23.7871 to 23.8125 mm) 0.8126 to 0.8130 inch (I.D.) (20.6400 to 20.6502 mm)		
206L/ L1/L3/ L4	206-001-563-013	MS27641-5 0.8125 to 0.8130 inch (20.6375 to 20.6502 mm)	None	Not Staked	 
206A/B 206B3	206-001-567	MS27641-5 0.8113 to 0.8118 inch (20.6070 to 20.6197 mm)	None	Not Staked	 
206A/B 206B3	206-001-568	MS14104-3 0.5615 to 0.5620 inch (14.2621 to 14.2748 mm)	120-015-12A 0.6978 to 0.6988 inch (17.7241 to 17.7495 mm)	Ring Stake	 
		MS27647-4/ 20-082-4 0.7488 to 0.7493 inch (19.0195 to 19.0322 mm)	120-015-4KA 0.8655 to 0.8665 inch (21.9837 to 22.0091 mm)	Ring Stake T101873-3	 

Table 9-5. Bearing and Sleeve Replacement Data (Cont)







MODEL	COMPONENT	BEARING P/N AND HOLE (BORE) SIZE FOR BEARING	SLEEVE P/N AND HOLE (BORE) SIZE FOR SLEEVE	TYPE STAKE AND TOOL NUMBER	NOTES
206A/B 206B3 206L/ L1/L3/ L4 407 427	206-001-702-009	MS27647-4/ 20-082-4/ DW4 0.7488 to 0.7493 in. (19.0195 to 19.0322 mm)	None	Roll Stake	
206L/ L1/L3/ L4	206-001-707-009	MS27647-5 0.8738 to 0.8743 inch (22.1945 to 22.2072 mm)	120-015-5A 0.999 to 1.000 inch (25.3746 to 25.4000 mm)	Ring Stake T101873-11	 
407	206-001-707-105 206-001-707-119 206-001-707-127	MS27647-5 0.8738 to 0.8743 inch (22.1945 to 22.2072 mm)	120-015-5A 0.999 to 1.000 inch (25.3746 to 25.4000 mm)	Ring Stake T101873-11	 
407	206-001-748	MS27647-5/ DW5 0.8738 to 0.8743 inch (22.1945 to 22.2072 mm)	None	Roll Stake	
206A/B 206B3	206-001-756	MS27647-4/ 20-082-4 0.7488 to 0.7493 in. (19.0195 to 19.0322 mm)	120-015-4KA 0.8655 to 0.8665 in. (21.9837 to 22.0091 mm)	Ring Stake T101873-3	 

Table 9-5. Bearing and Sleeve Replacement Data (Cont)















MODEL	COMPONENT	BEARING P/N AND HOLE (BORE) SIZE FOR BEARING	SLEEVE P/N AND HOLE (BORE) SIZE FOR SLEEVE	TYPE STAKE AND TOOL NUMBER	NOTES
206L/ L1/L3/ L4	206-001-759	MS27647-6 1.0613 to 1.0618 inches (26.9570 to 26.9697 mm)	120-015-6A 1.1865 to 1.1875 inches (30.1371 to 30.1625 mm)	Ring Stake T101873-15	 
206L/ L1/L3/ L4	206-001-763	MS27647-4/ 20-082-4 0.7488 to 0.7493 inch (19.0195 to 19.0322 mm)	120-015-4KA 0.8655 to 0.8665 inch (21.9837 to 22.0091 mm)	Ring Stake T101873-3	 
206L/ L1/L3/ L4	206-001-780	MS27641-5 0.8125 to 0.8130 inch (20.6375 to 20.6502 mm)	None	Not Staked	 
206L/ L1/L3/ L4	206-001-782	MS27641-5 0.8125 to 0.8130 inch (20.6375 to 20.6502 mm)	None	Not Staked	 
206L/ L1/L3/ L4	206-001-903	MS27647-5/ 20-082-5 0.8738 to 0.8743 inch (22.1945 to 22.2072 mm)	120-015-5A 0.999 to 1.000 inch (25.3746 to 25.4000 mm)	Ring Stake T101873-11	 
206L/f L1/L3/ L4	206-001-904	MS27647-4/ 20-082-4 0.7488 to 0.7493 inch (19.0195 to 19.0322 mm)	120-015-4KA 0.8655 to 0.8665 inch (21.9837 to 22.0091 mm)	Ring Stake T101873-3	 
206L/ L1/L3/ L4	206-001-905	MS27647-4/ 20-082-4 0.7488 to 0.7493 inch (19.0195 to 19.0322 mm)	120-015-4KA 0.8655 to 0.8665 inch (21.9837 to 22.0091 mm)	Ring Stake T101873-3	 

Table 9-5. Bearing and Sleeve Replacement Data (Cont)



















MODEL	COMPONENT	BEARING P/N AND HOLE (BORE) SIZE FOR BEARING	SLEEVE P/N AND HOLE (BORE) SIZE FOR SLEEVE	TYPE STAKE AND TOOL NUMBER	NOTES
206L/ L1/L3/ L4	206-001-906	MS27647-4/ 20-082-4 0.7488 to 0.7493 inch (19.0195 to 19.0322 mm)	120-015-4KA 0.8655 to 0.8665 inch (21.9837 to 22.0091 mm)	Ring Stake T101873-3	 
206A/B 206B3	206-010-336	206-010-469-001/ 206-010-470-101 0.9375 to 0.9380 inch (23.8125 to 23.8252 mm)	None	Roll Stake T101530-3 or RST2012 	 
206A/B 206B3	206-010-451	206-010-469-001/ 206-010-470-101 0.9375 to 0.9380 inch (23.8125 to 23.8252 mm)	None	Roll Stake T101530-3 or RST2012 	  
206A/B 206B3/ 206L/ L1/L3/ L4	206-010-453	206-010-469-001/ 206-010-470-101 0.9375 to 0.9380 inch (23.8125 to 23.8252 mm)	None	Roll Stake T101530-3 or RST2012 	  
206A/B 206B3	206-010-467	206-010-469-001/ 206-010-470-101 0.9375 to 0.9380 inch (23.8125 to 23.8252 mm)	None	Roll Stake T101530-3 or RST2012 	  
206A/B	206-011-139	MS27644-4 0.8999 to 0.9004 inch (22.8575 to 22.8702 mm)	None	Not Staked	
206A/B	206-011-721	MS20201KP4A/ NA27641-4 0.7488 to 0.7500 inch (19.0195 to 19.0500 mm)	None	Not Staked	

Table 9-5. Bearing and Sleeve Replacement Data (Cont)























MODEL	COMPONENT	BEARING P/N AND HOLE (BORE) SIZE FOR BEARING	SLEEVE P/N AND HOLE (BORE) SIZE FOR SLEEVE	TYPE STAKE AND TOOL NUMBER	NOTES
206A/B	206-011-722	MS20201KP5A 0.8113 to 0.8118 inch (20.6070 to 20.6197 mm)	None	Not Staked	
206A/B	206-011-723	DW4/ MS27647-4/ 20-082-4 0.7488 to 0.7493 inch (19.0195 to 19.0322 mm)	None	Segment Stake	  
206A/B	206-016-201	206-010-765-001	206-010-733-003	Roll Stake T101529	 
206L/ L1/L3/ L4	206-023-101	209-001-051-1 0.6562 to 0.6567 inch (16.6675 to 16.6802 mm)	None	Anvil Stake T102095-3	 
206A/B	206-030-539	MS14103-6 0.8123 to 0.8128 inch (20.633 to 20.645 mm)	None	Anvil Stake AT-6-435 	 
206A/B	206-031-509	BSH-16-ATC32ZM 1.0010 to 1.0035 inches (25.4254 to 25.4889 mm)	206-031-513-101 1.1272 to 1.1292 inches (28.6309 to 28.6817 mm)	Segment Stake T101547	    
206A/B	206-031-589	206-031-590-003 1.4275 to 1.4380 inches (36.5125 to 36.5252 mm)	None	Roll Stake T101584	   
206A/B	206-031-592	206-031-594-003 0.9375 to 0.9380 inch (23.8125 to 23.8252 mm)	None	Roll Stake T101530-5	  

Table 9-5. Bearing and Sleeve Replacement Data (Cont)



















MODEL	COMPONENT	BEARING P/N AND HOLE (BORE) SIZE FOR BEARING	SLEEVE P/N AND HOLE (BORE) SIZE FOR SLEEVE	TYPE STAKE AND TOOL NUMBER	NOTES
206A/B	206-031-593	206-031-594-003 0.9375 to 0.9380 inch (23.8125 to 23.8252 mm)	None	Roll Stake T101530-5	 
206L/ L1/L3	206-033-503	206-033-508-003 1.3750 to 1.3755 inches (34.9250 to 34.9377 mm)	None	Roll Stake 30125 	  
		206-033-519-003 1.3750 to 1.3755 inches (34.9250 to 34.9377 mm)	None	Roll Stake 30125 	 
206L/ L1/L3/ L4	206-033-506				
206A/B	206-062-717	RSST-3/ LHSSR-3 0.5615 to 0.5620 inch (14.2621 to 14.2748 mm)	206-062-714-001 0.6779 to 0.6789 inch (17.2187 to 17.2441 mm)	Ring Stake	 
206A/B 206B3	206-062-723	DW4/ DW4K/ MS27647-4/ 20-082-4 0.7488 to 0.7493 inch (19.0195 to 19.0322 mm)	120-015-4KA 0.8655 to 0.8665 inch (21.9837 to 22.0091 mm)	Ring Stake T101873-3	 
206A/B	206-062-747	RSST-4/ LHSSV-4 0.6552 to 0.6557 inch (16.6421 to 16.6548 mm)	209-060-738-1 0.7701 to 0.7711 inch (19.5605 to 19.5859 mm)	Ring Stake	   

Table 9-5. Bearing and Sleeve Replacement Data (Cont)









MODEL	COMPONENT	BEARING P/N AND HOLE (BORE) SIZE FOR BEARING	SLEEVE P/N AND HOLE (BORE) SIZE FOR SLEEVE	TYPE STAKE AND TOOL NUMBER	NOTES
206L/ L1/L3/ L4	206-063-708	MS14102-6 (For -001 only) AW6SS (For -101 only) 0.8113 to 0.8118 inch (20.6070 to 20.6197 mm)	120-012-51A 0.9365 to 0.9375 inch (23.7871 to 23.8125 mm)	Ring Stake T101873-7	
206L/ L1/L3/ L4	206-063-709	MS14102-3 0.6238 to 0.6243 inch (15.8445 to 15.8572 mm)	120-012-31A 0.7490 to 0.7500 inch (19.0246 to 19.0500 mm)	Ring Stake	
206L/ L1/L3/ L4	206-063-714	MS27647-4/ 20-082-4 0.7488 to 0.7493 inch (19.0195 to 19.0322 mm)	120-015-4KA 0.8655 to 0.8665 inch (21.9837 to 22.0091 mm)	Ring Stake T101873-3	
206L/ L1/L3/ L4/407	206-063-719	MS27640-4			
214ST	209-010-494	Refer to BHT-214ST-CR&O			
205A-1	209-030-357	RG9SS/ 12-2-0-00-09/ MS14101-9 1.0932 to 1.0937 inches (27.7673 to 27.7800 mm)	None	Roll Stake RT-101-9 	
212 412	212-001-188	DW4/ MS27647-4 0.7488 to 0.7493 inch (19.0195 to 19.0322 mm)	120-015-4KA 0.8655 to 0.8665 inch (21.90837 to 22.0091 mm)	Ring Stake T101873-3	
212 412	212-001-210	209-001-051-001 0.6562 to 0.6567 inch (16.6675 to 16.6802 mm)	None	Ring Stake T102095-3	

Table 9-5. Bearing and Sleeve Replacement Data (Cont)









MODEL	COMPONENT	BEARING P/N AND HOLE (BORE) SIZE FOR BEARING	SLEEVE P/N AND HOLE (BORE) SIZE FOR SLEEVE	TYPE STAKE AND TOOL NUMBER	NOTES
212 412	212-001-210	MS20206DSP4/ MS27643-4 0.9002 to 0.9007 inch (22.8651 to 22.8778 mm)	120-013-4A 1.0285 to 1.0295 inches (26.1239 to 26.1493 mm)	Ring Stake T101873-13	
		DW5/ MS27647-5 0.8738 to 0.8743 inch (22.1945 to 22.2072 mm)	120-015-5A 0.9995 to 1.0000 inch (25.3873 to 25.4000 mm)	Ring Stake T101873-11	
212	212-001-253	MS27643-4 0.9002 to 0.9007 inch (22.8651 to 22.8778 mm)	120-013-4A 1.0285 to 1.0295 inches (26.1239 to 26.1493 mm)	Ring Stake T101873-13	
212	212-001-256	None 0.7501 to 0.7505 inch (19.0525 to 19.0627 mm)	120-012-4S 0.8655 to 0.8665 inch (21.9837 to 22.0091 mm)	Ring Stake	
212	212-001-257	MS27645-5 1.2488 to 1.2493 inches (31.7195 to 31.7322 mm)	120-011-5A 1.3740 to 1.3750 inches (34.8996 to 34.9250 mm)	Ring Stake T101873-19	
212	212-001-312	MS20206DSP4/ MS27643-4 0.9002 to 0.9007 inch (22.8651 to 22.8778 mm)	120-013-4A 1.0285 to 1.0295 inches (26.1239 to 26.1493 mm)	Ring Stake T101873-13	
		DW5/ MS27647-5 0.8738 to 0.8743 inch (22.1945 to 22.2072 mm)	120-015-5A 0.9995 to 1.0000 inch (25.3873 to 25.4000 mm)	Ring Stake  T101873-11	 or 

Table 9-5. Bearing and Sleeve Replacement Data (Cont)





















MODEL	COMPONENT	BEARING P/N AND HOLE (BORE) SIZE FOR BEARING	SLEEVE P/N AND HOLE (BORE) SIZE FOR SLEEVE	TYPE STAKE AND TOOL NUMBER	NOTES
212 412	212-001-313	MS27641-4  0.7501 to 0.7505 inch (19.0525 to 19.0627 mm)	N/A	Not Staked	 
212	212-001-317-001	MS20206DSP4/ MS27643-4 0.9002 to 0.9007 inch (22.8651 to 22.8778 mm)	120-013-4A 1.0285 to 1.0295 inches (26.1239 to 26.1493 mm)	Ring Stake  T101873-13	 or 
		MS27647-5 (20- 082-5) 0.8738 to 0.8743 inch (22.1945 to 22.2072 mm)	120-015-5A 0.9995 to 1.0000 inch (25.3873 to 25.4000 mm)	Ring Stake  T101873-11	 or 
212	212-001-321	AN206DPSP4 MS27643-4 0.9002 to 0.9007 inch (22.8651 to 22.8778 mm)	120-013-4A 1.0285 to 1.0295 inches (26.1239 to 26.1493 mm)	Ring Stake T101873-13	 
212 412	214 212-001-501	MS20206DSP4/ MS27643-4 0.9002 to 0.9007 inch (22.8651 to 22.8778 mm)	120-013-4A 1.0285 to 1.0295 inches (26.1239 to 26.1493 mm)	Ring Stake  T101873-13	 or 
205A-1 212 412	212-001-705	MS20206DSP4/ MS27643-4 0.9002 to 0.9007 inch (22.8651 to 22.8778 mm)	120-013-4A 1.0285 to 1.0295 inches (26.1239 to 26.1493 mm)	Ring Stake  T101873-13	 or 
		DSRP-4 0.9002 to 0.9007 inch (22.8651 to 22.8778 mm)	120-013-4A 1.0285 to 1.0295 inches (26.1239 to 26.1493 mm)	Ring Stake  T101873-13	 or 

Table 9-5. Bearing and Sleeve Replacement Data (Cont)

MODEL	COMPONENT	BEARING P/N AND HOLE (BORE) SIZE FOR BEARING	SLEEVE P/N AND HOLE (BORE) SIZE FOR SLEEVE	TYPE STAKE AND TOOL NUMBER	NOTES
205A-1 212 412	212-001-705	MDW5/MS27647-5 0.8738 to 0.8743 inch (22.1945 to 22.2072 mm)	120-015-5A 0.9995 to 1.0000 inch (25.3873 to 25.4000 mm)	Ring Stake \triangle_4 T101873-11	\triangle_1 or \triangle_{16}
212 412	212-001-708-001	MS27647-5 0.8738 to 0.8743 inch (22.1945 to 22.2072 mm)	120-015-5A 0.9995 to 1.0000 inch (25.3873 to 25.4000 mm)	Ring Stake \triangle_4 T101873-11	\triangle_1 or \triangle_{16}
		MS27643-4 0.9002 to 0.9007 inch (22.8651 to 22.8778 mm)	120-013-4A 1.0285 to 1.0295 inches (26.1239 to 26.1493 mm)	Ring Stake \triangle_4 T101873-13	\triangle_1 or \triangle_{16}
212 412	212-001-710-001	212-001-066-001 0.7488 to 0.7493 inch (19.0195 to 19.0322 mm)	120-015-4KA 0.8655 to 0.8665 inch (21.9837 to 22.0091 mm)	Ring Stake \triangle_4 T101873-3	\triangle_1 or \triangle_{16}
		MS27643-4/ MS20206DSP4 0.9002 to 0.9007 inch (22.8651 to 22.8778 mm)	120-013-4A 1.0285 to 1.0295 inches (26.1239 to 26.1493 mm)	Ring Stake T101873-13	\triangle_1 or \triangle_{16}
212	212-001-711	MS20206DSP4 MS27643-4/ 0.9002 to 0.9007 inch (22.8651 to 22.8778 mm)	120-013-4A 1.0285 to 1.0295 inches (26.1239 to 26.1493 mm)	Ring Stake \triangle_4 T101873-13	\triangle_1 or \triangle_{16}
		DW4/ MS27647-4 0.7488 to 0.7493 inch (19.0195 to 19.0322 mm)	120-015-4KA 0.8655 to 0.8665 inch (21.9837 to 22.0091 mm)	Ring Stake \triangle_4 T101873-3	\triangle_1 or \triangle_{16}
205A-1 212	212-001-712-101	DSRP-4 0.9002 to 0.9007 inch (22.8651 to 22.8778 mm)	120-013-4A 1.0285 to 1.0295 inches (26.1239 to 26.1493 mm)	Ring Stake \triangle_4 T101873-13	\triangle_1 or \triangle_{16}

Table 9-5. Bearing and Sleeve Replacement Data (Cont)

























MODEL	COMPONENT	BEARING P/N AND HOLE (BORE) SIZE FOR BEARING	SLEEVE P/N AND HOLE (BORE) SIZE FOR SLEEVE	TYPE STAKE AND TOOL NUMBER	NOTES
212 412	212-001-747-001	MS27647-5 0.8738 to 0.8743 inch (22.1945 to 22.2072 mm)	120-015-5A 0.9990 to 1.0000 inch (23.3746 to 25.4000 mm)	Ring Stake  T101873-11	 or 
		MS27643-4 0.9002 to 0.9007 inch (22.8651 to 22.8778 mm)	120-013-4A 1.0285 to 1.0295 inches (26.1239 to 26.1493 mm)	Ring Stake  T101873-13	 or 
212	212-001-749	MS27643-4 0.9002 to 0.9007 inch (22.8651 to 22.8778 mm)	120-013-4A 1.0285 to 1.0295 inches (26.1239 to 26.1493 mm)	Ring Stake  T101873-13	 or 
		DPP8W 1.6863 to 1.6868 inches (42.8320 to 42.8447 mm)	120-014-8A 1.8115 to 1.8125 inches (46.0121 to 46.0375 mm)	Ring Stake  T101873-13	 or 
212	212-001-750	MS27643-4 0.9002 to 0.9007 inch (22.8651 to 22.8778 mm)	120-013-4A 1.0285 to 1.0295 inches (26.1239 to 26.1493 mm)	Ring Stake  T101873-13	 or 
212	212-001-751	MS27643-4 0.9002 to 0.9007 inch (22.8651 to 22.8778 mm)	120-013-4A 1.0285 to 1.0295 inches (26.1239 to 26.1493 mm)	Ring Stake  T101873-13	 or 
212	212-001-753-002	MS27645-5 1.2493 to 1.2500 inches (31.7322 to 31.7500 mm)	120-011-5A 1.3740 to 1.3750 inches (34.8996 to 34.9250 mm)	Ring Stake  T101873-19	 or 
205A-1 212 412	212-001-758-105	DSRP-4 0.9002 to 0.9007 inch (22.8651 to 22.8778 mm)	120-013-4A 1.0285 to 1.0295 inches (26.1239 to 26.1493 mm)	Ring Stake  T101873-13	 or 

Table 9-5. Bearing and Sleeve Replacement Data (Cont)

MODEL	COMPONENT	BEARING P/N AND HOLE (BORE) SIZE FOR BEARING	SLEEVE P/N AND HOLE (BORE) SIZE FOR SLEEVE	TYPE STAKE AND TOOL NUMBER	NOTES
205A-1 212 412	212-001-759-101	DSRP-4 0.9002 to 0.9007 inch (22.8651 to 22.8778 mm)	120-013-4A 1.0285 to 1.0295 inches (26.1239 to 26.1493 mm)	Ring Stake \triangle_4 T101873-13	\triangle_1 or \triangle_{18}
		MS27647-5 0.8738 to 0.8743 inch (22.1945 to 22.2072 mm)	120-015-5A 0.999 to 1.000 inch (25.375 to 25.400 mm)	Ring Stake \triangle_4 T101873-11	\triangle_1 or \triangle_{18}
212	212-001-900-001	MS20202DSP4/ MS27643-4 0.9002 to 0.9007 inch (22.8651 to 22.8778 mm)	120-013-4A 1.0285 to 1.0295 inches (26.1239 to 26.1493 mm)	Ring Stake \triangle_4 T101873-13	\triangle_1 or \triangle_{16}
		MDW5/ MS27647-5 0.8738 to 0.8743 inch (22.1945 to 22.2072 mm)	120-015-5A 0.999 to 1.000 inch (25.3746 to 25.400 mm)	Ring Stake \triangle_4 T101873-11	\triangle_1 or \triangle_{18}
212	212-001-901	MS20206DSP4/ MS27643-4 0.9002 to 0.9007 inch (22.8651 to 22.8778 mm)	120-013-4A 1.0285 to 1.0295 inches (26.1239 to 26.1493 mm)	Ring Stake \triangle_4 T101873-13	\triangle_1 or \triangle_{16}
		MDW5/ MS27647-5 0.8738 to 0.8743 inch (22.1945 to 22.2072 mm)	120-015-5A 0.999 to 1.000 inch (25.375 to 25.400 mm)	Ring Stake \triangle_4 T101873-11	\triangle_1 or \triangle_{16}
212	212-001-902	MS20206DSP4/ MS27643-4 0.9002 to 0.9007 inch (22.8651 to 22.8778 mm)	120-013-4A 1.0285 to 1.0295 inches (26.1239 to 26.1493 mm)	Ring Stake \triangle_4 T101873-13	\triangle_1 or \triangle_{18}

Table 9-5. Bearing and Sleeve Replacement Data (Cont)





















MODEL	COMPONENT	BEARING P/N AND HOLE (BORE) SIZE FOR BEARING	SLEEVE P/N AND HOLE (BORE) SIZE FOR SLEEVE	TYPE STAKE AND TOOL NUMBER	NOTES
212	212-001-902	MS20206DSP5/ MS27643-5 1.2488 to 1.2493 inches (31.7195 to 31.7322 mm)	120-013-5A 1.374 to 1.375 inches (34.900 to 34.924 mm)	Ring Stake  T101873-19	 or 
		MDW4/ 212-001-066-001 0.7488 to 0.7493 inch (19.0195 to 19.0322 mm)	120-015-4KA 0.855 to 0.8665 inch (21.9837 to 2.0091 mm)	Ring Stake 	 or 
205A-1 212	212-010-302	MS28913-5C  1.2485 to 1.2490 inches (31.7119 to 31.7246 mm)	120-014-5A  1.374 to 1.375 inches (34.900 to 34.925 mm)	Ring Stake T101873-19	 
		MS20201KP10A/ MS27641-10 1.3740 to 1.3745 inches (34.8996 to 34.9123 mm)	204-010-422-021 1.500 to 1.501 inches (38.100 to 38.125 mm)	None	 or 
205A-1 212	212-010-403	MS20201KP8/ MS27641-8 1.1240 to 1.1245 inches (28.5946 to 28.5623 mm)	204-010-422-023 1.2495 to 1.2510 inches (31.7373 to 31.7754 mm)	Ring Stake T101873-17	 
205A-1 212	212-010-407	MS28913-5C 1.2488 to 1.2493 inches (31.7195 to 31.7322 mm)	120-013-5A/ 23S5-5 1.3745 to 1.3750 inches (34.9123 to 34.9250 mm)	Ring Stake T101873-19	 
205A-1 212	212-010-412		None		
205A-1 212 412	212-030-104-101	209-031-351-001 1.4380 to 1.4383 inches (36.5252 to 36.5328 mm) After peening	None	Roll Stake RST1016 	 

Table 9-5. Bearing and Sleeve Replacement Data (Cont)













MODEL	COMPONENT	BEARING P/N AND HOLE (BORE) SIZE FOR BEARING	SLEEVE P/N AND HOLE (BORE) SIZE FOR SLEEVE	TYPE STAKE AND TOOL NUMBER	NOTES
205A-1 212 412	212-030-104-5	MS14101-4 1.0932 to 1.0937 inches (27.7673 to 27.7800 mm) After peening	None	Roll Stake 	 or 
212	212-060-210	MS20201KP3A 0.6238 to 0.6243 inch (15.8445 to 15.8572 mm)	120-012-3A 0.7490 to 0.7500 inch (19.0246 to 19.0500 mm)	Roll Stake T10873-3	
212	212-060-740-001	MS27647-4 0.8655 to 0.8665 inch (21.9837 to 22.0091 mm)	120-015-4KA 0.7493 to 0.7488 inch (19.0322 to 19.0195 mm)	Ring Stake T101873-3	 
214B	214-001-021	WBS-8ATC21Z 0.6562 to 0.6567 inch (16.6675 to 16.6802 mm)	None	Not Staked	
214B 214ST	214-001-051	Refer to BHT-214B-CR&O or BHT-214ST-CR&O			
214B	214-001-109	MS27643-4 0.9002 to 0.9007 inch (22.8651 to 22.8778 mm)	120-013-4A 1.0285 to 1.0295 inches (26.1239 to 26.1493 mm)	Ring Stake T101873-13	 
		MS27643-3 0.7762 to 0.7767 inch (19.7155 to 19.7282 mm)	120-013-3A 0.9055 to 0.9065 inch (22.9997 to 23.0251 mm)	Ring Stake T101873-5	 
214B 214ST	214-001-110	209-001-051-001 0.6562 to 0.6567 inch (16.6675 to 16.6802 mm)	None	Anvil Stake T102095-3	 

Table 9-5. Bearing and Sleeve Replacement Data (Cont)









MODEL	COMPONENT	BEARING P/N AND HOLE (BORE) SIZE FOR BEARING	SLEEVE P/N AND HOLE (BORE) SIZE FOR SLEEVE	TYPE STAKE AND TOOL NUMBER	NOTES
214B 214ST	214-001-111	209-001-051-001 0.6562 to 0.6567 inch (16.6675 to 16.6802 mm)	None	Anvil Stake T102095-3	
	214-001-128	209-001-051-001 0.6562 to 0.6567 inch (16.6675 to 16.6802 mm)	None	Anvil Stake T102095-3	
214B	214-001-130	MS27643-4 0.9002 to 0.9007 inch (22.8651 to 22.8778 mm)	120-013-4A 1.0285 to 1.0295 inches (26.1239 to 26.1493 mm)	Ring Stake T101873-13	
		MS27647-5 0.8738 to 0.8743 inch (22.1945 to 22.2072 mm)	120-015-5A 0.9990 to 1.0000 inch (25.3746 to 25.4000 mm)	Ring Stake T101873-11	
			214-001-131-001 I.D. 1.8598 to 1.8606 inches (47.2389 to 47.2592 mm)		
214ST	214-001-137	MS27643-3 0.7762 to 0.7767 inch (19.7155 to 19.7282 mm)	120-013-3A 0.9055 to 0.9065 inch (22.9997 to 23.0251 mm)	Ring Stake T101873-5	
		MS27643-4 0.9002 to 0.9007 inch (22.8651 to 22.8778 mm)	120-013-4A 1.0285 to 1.0295 inches (26.1239 to 26.1493 mm)	Ring Stake T101873-13	
214ST	214-001-163	MS27647-5/ 20-082-5 0.8738 to 0.8743 inch (22.1945 to 22.2072 mm)	120-015-5A 0.9990 to 1.0000 inch (25.3746 to 25.4000 mm)	Ring Stake T101873-11	

Table 9-5. Bearing and Sleeve Replacement Data (Cont)





MODEL	COMPONENT	BEARING P/N AND HOLE (BORE) SIZE FOR BEARING	SLEEVE P/N AND HOLE (BORE) SIZE FOR SLEEVE	TYPE STAKE AND TOOL NUMBER	NOTES
214ST	214-001-163	MS27643-4 0.9002 to 0.9007 inch (22.8651 to 22.8778 mm)	120-013-4A 1.0285 to 1.0295 inches (26.1239 to 26.1493 mm)	Ring Stake T101873-13	
214ST	214-001-164	MS27643-4 0.9002 to 0.9007 inch (22.8651 to 22.8778 mm)	120-013-4A 1.0285 to 1.0295 inches (26.1239 to 26.1493 mm)	Ring Stake T101873-13	
		MS27647-4 or 20-082-4 0.7488 to 0.7493 inch (19.0195 to 19.0322 mm)	120-015-4K 0.8655 to 0.8665 inch (21.9837 to 22.0091 mm)	Ring Stake T101873-3	
214ST	214-001-169	MS27643-4 0.9002 to 0.9007 inch (22.8651 to 22.8778 mm)	120-013-4A 1.0285 to 1.0295 inches (26.1239 to 26.1493 mm)	Ring Stake T101873-13	
214ST	214-001-196	MS27643-4 0.9002 to 0.9007 inch (22.8651 to 22.8778 mm)	120-013-4A 1.0285 to 1.0295 inches (26.1239 to 26.1493 mm)	Ring Stake T101873-13	
214ST	214-001-202	MS27643-4 0.9002 to 0.9007 inch (22.8651 to 22.8778 mm)	120-013-4A 1.0285 to 1.0295 inches (26.1239 to 26.1493 mm)	Ring Stake T101873-13	
214B 214ST	214-001-309	MS20206DPSP4/ MS27643-4 0.9002 to 0.9007 inch (22.8651 to 22.8778 mm)	120-013-4A 1.0285 to 1.0295 inches (26.1239 to 26.1493 mm)	Ring Stake T101873-13	
214B	214-001-313-101	MS27641-4 0.7488 to 0.7493 inch (19.0195 to 19.0322 mm)	120-012-4A 0.8655 to 0.8665 inch (21.9837 to 22.0091 mm)	Ring Stake T101873-3	

Table 9-5. Bearing and Sleeve Replacement Data (Cont)







MODEL	COMPONENT	BEARING P/N AND HOLE (BORE) SIZE FOR BEARING	SLEEVE P/N AND HOLE (BORE) SIZE FOR SLEEVE	TYPE STAKE AND TOOL NUMBER	NOTES
214B	214-001-313-101	None I.D. 0.7501 to 0.7505 inch (19.0525 to 19.0627 mm)	120-012-4S 0.8660 to 0.8665 inch (21.9964 to 22.0091 mm)	Ring Stake T101873-3	
		MS27643-4 0.9002 to 0.9007 inch (22.8651 to 22.8778 mm)	20-013-4A 1.0285 to 1.0295 inches (26.1239 to 26.1493 mm)	Ring Stake T101873-13	
214B	214-001-314	MS27643-4 0.9002 to 0.9007 inch (22.8651 to 22.8778 mm)	120-013-4A 1.0285 to 1.0295 inches (26.1239 to 26.1493 mm)	Ring Stake T101873-13	
		MS27647-5 0.8738 to 0.8743 inch (22.1945 to 22.2072 mm)	120-015-5A 0.9990 to 1.0000 inch (25.3746 to 25.4000 mm)	Ring Stake T101873-11	
214B	214-001-318	209-001-051-001 0.6562 to 0.6567 inch (16.6675 to 16.6802 mm)	None	Anvil Stake T102095-3	
			214-001-127-001 0.7498 to 0.7502 inch (19.0449 to 9.0551 mm)	Anvil Stake T102015-9	
214B	214-001-319	MS27643-4 0.9002 to 0.9007 inch (22.8651 to 22.8778 mm)	120-013-4A 1.0285 to 1.0295 inches (26.1239 to 26.1493 mm)	Ring Stake T101873-13	
		or 214-001-356	MS27647-5 0.8738 to 0.8743 inch (22.1945 to 22.2072 mm)	120-015-5A 0.9990 to 1.0000 inch (25.3746 to 25.4000 mm)	Ring Stake T101873-11

Table 9-5. Bearing and Sleeve Replacement Data (Cont)













MODEL	COMPONENT	BEARING P/N AND HOLE (BORE) SIZE FOR BEARING	SLEEVE P/N AND HOLE (BORE) SIZE FOR SLEEVE	TYPE STAKE AND TOOL NUMBER	NOTES
214B	214-001-325	MS27643-4 0.9002 to 0.9007 inch (22.8651 to 22.8778 mm)	120-013-4A 1.0285 to 1.0295 inches (26.1239 to 26.1493 mm)	Ring Stake T101873-13	 
214B	214-001-327	MS27643-4 0.9002 to 0.9007 inch (22.8651 to 22.8778 mm)	120-013-4A 1.0285 to 1.0295 inches (26.1239 to 26.1493 mm)	Ring Stake T101873-13	 
214B	214-001-356	Refer to 214-001-319			
214ST	214-001-371	MS27643-4 0.9002 to 0.9007 inch (22.8651 to 22.8778 mm) (2-places)	120-013-4A 1.0285 to 1.0295 inches (26.1239 to 26.1493 mm)	Ring Stake T101873-13	 
		MS27641-5 0.8125 to 0.8130 inch (20.6375 to 20.6502 mm) (Lobe side)	None	Not Staked	
		MS27641-5 0.8113 to 0.8118 inch (20.6100 to 20.6200 mm) (Flat side)	None	Not Staked	
214ST	214-001-373	MS27641-4 0.7488 to 0.7493 inch (19.0195 to 19.0322 mm)	120-012-4A 0.8655 to 0.8665 inch (21.9837 to 22.0091 mm)	Ring Stake T101873-3	 
		None 0.7501 to 0.7505 inch (19.0525 to 19.0627 mm) (Sleeve I.D.)	120-012-4S 0.8655 to 0.8665 inch (21.9837 to 22.0091 mm)	Ring Stake T101873-3	 

Table 9-5. Bearing and Sleeve Replacement Data (Cont)









MODEL	COMPONENT	BEARING P/N AND HOLE (BORE) SIZE FOR BEARING	SLEEVE P/N AND HOLE (BORE) SIZE FOR SLEEVE	TYPE STAKE AND TOOL NUMBER	NOTES
214ST	214-001-376	MS27643-4 0.9002 to 0.9007 inch (22.8651 to 22.8778 mm)	120-013-4A 1.0285 to 1.0295 inches (26.1239 to 26.1493 mm)	Ring Stake T101873-13	
		MS27641-4 0.7488 to 0.7493 inch (19.0195 to 19.0322 mm)	None	Not Staked	
214ST	214-001-379	MS27643-4 0.9002 to 0.9007 inch (22.8651 to 22.8778 mm)	120-013-4A 1.0285 to 1.0295 inches (26.1239 to 26.1493 mm)	Ring Stake T101873-13	
214B	214-001-500	MS20206DSP4 0.9002 to 0.9007 inch (22.8651 to 22.8778 mm)	120-013-4A 1.0285 to 1.0295 inches (26.1239 to 26.1493 mm)	Ring Stake T101873-13	
		212-001-066-001 0.7488 to 0.7493 inch (19.0195 to 19.0322 mm)	120-015-4KA 0.8655 to 0.8665 inch (21.9837 to 22.0091 mm)	Ring Stake T101873-3	
412	214-001-500-001	212-001-066-001 0.7488 to 0.7493 inch (19.0195 to 19.0322 mm)	120-012-4KA 0.8655 to 0.8665 inch (21.9837 to 22.0091 mm)	Ring Stake T101873-3	
		MS27643-4 0.9002 to 0.9007 inch (22.8651 to 22.8778 mm)	120-013-4A 1.0285 to 1.0295 inches (26.1239 to 26.1493 mm)	Ring Stake T101873-13	
214B	214-001-501-005	MS20206DSP4 0.9002 to 0.9007 inch (22.8651 to 22.8778 mm)	120-013-4A 1.0285 to 1.0295 inches (26.1239 to 26.1493 mm)	Ring Stake T101873-13	

Table 9-5. Bearing and Sleeve Replacement Data (Cont)









MODEL	COMPONENT	BEARING P/N AND HOLE (BORE) SIZE FOR BEARING	SLEEVE P/N AND HOLE (BORE) SIZE FOR SLEEVE	TYPE STAKE AND TOOL NUMBER	NOTES
412	214-001-501-101	MS27643-4 0.9002 to 0.9007 inch (22.8651 to 22.8778 mm)	120-013-4A 1.0285 to 1.0295 inches (26.1239 to 26.1493 mm)	Ring Stake T101873-13	
214B	214-001-504	MS27643-4 0.9002 to 0.9007 inch (22.8651 to 22.8778 mm)	120-013-4A 1.0285 to 1.0295 inches (26.1239 to 26.1493 mm)	Ring Stake T101873-13	
		MS27641-4 0.7488 to 0.7493 inch (19.0195 to 19.0322 mm)	120-012-4A 0.8655 to 0.8665 inch (21.9837 to 22.0091 mm)	Ring Stake T101873-3	
		None 0.7501 to 0.7505 inch (19.0525 to 19.0627 mm)	120-012-4S 0.8655 to 0.8665 inch (21.9837 to 22.0091 mm)	Ring Stake T101873-3	
214B	214-001-505	MS27643-4 0.9002 to 0.9007 inch (22.8651 to 22.8778 mm)	120-013-4A 1.0285 to 1.0295 inches (26.1239 to 26.1493 mm)	Ring Stake T101873-13	
		MS27647-4/ 20-082-4 0.7488 to 0.7493 inch (19.0195 to 19.0322 mm)	120-015-4KA 0.8655 to 0.8665 inch (21.9837 to 22.0091 mm)	Ring Stake T101873-3	
214ST	214-001-542	MS27645-4 0.9002 to 0.9007 inch (22.8651 to 22.8778 mm)	120-011-4A 1.0285 to 1.0295 inches (26.1239 to 26.1493 mm)	Ring Stake T101873-13	
		MS27643-4 0.9002 to 0.9007 inch (22.8651 to 22.8778 mm)	120-013-4A 1.0285 to 1.0295 inches (26.1239 to 26.1493 mm)	Ring Stake T101873-13	

Table 9-5. Bearing and Sleeve Replacement Data (Cont)









MODEL	COMPONENT	BEARING P/N AND HOLE (BORE) SIZE FOR BEARING	SLEEVE P/N AND HOLE (BORE) SIZE FOR SLEEVE	TYPE STAKE AND TOOL NUMBER	NOTES
214ST	214-001-542	MS27647-4 or 20-082-4 0.7488 to 0.7493 inch (19.0195 to 19.0322 mm)	120-012-4KA 0.8655 to 0.8665 inch (21.9837 to 22.0091 mm)	Ring Stake T101873-3	
214ST	214-001-543	MS27641-4 0.7488 to 0.7493 inch (19.0195 to 19.0322 mm)	120-012-4A 0.8655 to 0.8665 inch (21.9837 to 22.0091 mm)	Ring Stake T101873-3	
		MS27643-4 0.9002 to 0.9007 inch (22.8651 to 22.8778 mm)	120-013-4A 1.0285 to 1.0295 inches (26.1239 to 26.1493 mm)	Ring Stake T101873-13	
214ST	214-001-553	MS27645-4A 0.7488 to 0.7493 inch (22.8651 to 22.8778 mm)	120-012-4A 0.8655 to 0.8665 inch (21.9800 to 22.0100 mm)	Ring Stake T101873-3	
214B	214-001-701	MS20206DSP4 0.9002 to 0.9007 inch (22.8651 to 22.8778 mm)	120-013-4A 1.0285 to 1.0295 inches (26.1239 to 26.1493 mm)	Ring Stake T101873-13	
		212-001-066-001 0.7488 to 0.7493 inch (22.8651 to 22.8778 mm)	120-015-4K4 0.8655 to 0.8665 inch (21.9837 to 22.0091 mm)	Ring Stake T101873-3	
214ST	214-001-708	MS27643-4 0.9002 to 0.9007 inch (22.8651 to 22.8778 mm)	120-013-4A 1.0285 to 1.0295 inches (26.1239 to 26.1493 mm)	Ring Stake T101873-13	
		MS27647-4 0.7488 to 0.7493 inch (22.8651 to 22.8778 mm)	120-015-4KA 0.8655 to 0.8665 inch (21.9837 to 22.0091 mm)	Ring Stake T101873-3	

Table 9-5. Bearing and Sleeve Replacement Data (Cont)







MODEL	COMPONENT	BEARING P/N AND HOLE (BORE) SIZE FOR BEARING	SLEEVE P/N AND HOLE (BORE) SIZE FOR SLEEVE	TYPE STAKE AND TOOL NUMBER	NOTES
214B	214-001-710	MS27643-4 0.9002 to 0.9007 inch (22.8651 to 22.8778 mm)	120-013-4A 1.0285 to 1.0295 inches (26.1239 to 26.1493 mm)	Ring Stake T101873-13	
		MS27641-4 0.7488 to 0.7493 inch (22.8651 to 22.8778 mm)	120-015-4A 0.8655 to 0.8665 inch (21.9837 to 22.0091 mm)	Ring Stake T101873-3	
		None I.D. 0.7501 to 0.7505 inch (19.0525 to 19.0627 mm)	120-012-4S 0.8655 to 0.8665 inch (21.9837 to 22.0091 mm)	Ring Stake T101873-3	
214B	214-001-714	MS27643-4 0.9002 to 0.9007 inch (22.8651 to 22.8778 mm)	120-013-4A 1.0285 to 1.0295 inches (26.1239 to 26.1493 mm)	Ring Stake T101873-13	
		MS27647-4 0.7488 to 0.7493 inch (22.8651 to 22.8778 mm)	120-015-4KA 0.8655 to 0.8665 inch (21.9837 to 22.0091 mm)	Ring Stake T101873-3	
214B	214-001-716	MS27643-4 0.9002 to 0.9007 inch (22.8651 to 22.8778 mm)	120-013-4A 1.0285 to 1.0295 inches (26.1239 to 26.1493 mm)	Ring Stake T101873-13	
		214-001-093-007 0.8655 to 0.8665 inch (21.9837 to 22.0091 mm)	206-001-708-001 I.D. 1.253 to 1.254 inches (31.826 to 31.852 mm) O.D. 1.4995 to 1.500 inches (38.0873 to 38.100 mm)	Ring Stake T101873-3 (One side)	

Table 9-5. Bearing and Sleeve Replacement Data (Cont)









MODEL	COMPONENT	BEARING P/N AND HOLE (BORE) SIZE FOR BEARING	SLEEVE P/N AND HOLE (BORE) SIZE FOR SLEEVE	TYPE STAKE AND TOOL NUMBER	NOTES
214B	214-001-721-001	MS27643-4 0.9002 to 0.9007 inch (22.8651 to 22.8778 mm)	120-013-4A 1.0285 to 1.0295 inches (26.1239 to 26.1493 mm)	Ring Stake T101873-13	
		MS27647-4 0.7488 to 0.7493 inch (19.0195 to 19.0322 mm)	120-015-4KA 0.8655 to 0.8665 inch (21.9837 to 22.0091 mm)	Ring Stake T101873-3	
214B 214ST	214-001-723	214-001-093-9 0.8655 to 0.8665 inch (21.9837 to 22.0091 mm)	None	Ring Stake T101873-3 (One side)	
214B	214-001-724	MS27643-4 0.9002 to 0.9007 inch (22.8651 to 22.8778 mm)	120-013-4A 1.0285 to 1.0295 inches (26.1239 to 26.1493 mm)	Ring Stake T101873-13	
		MS27647-4 0.7488 to 0.7493 inch (19.0195 to 19.0322 mm)	120-015-4KA 0.8655 to 0.8665 inch (21.9837 to 22.0091 mm)	Ring Stake T101873-3	
214ST	214-001-769	MS27643-4 0.9002 to 0.9007 inch (22.8651 to 22.8778 mm)	120-013-4A 1.0285 to 1.0295 inches (26.1239 to 26.1493 mm)	Ring Stake T101873-13	
		MS27641-4 0.7488 to 0.7493 inch (19.0195 to 19.0322 mm)	None	Not Staked	
214ST	214-001-779	MS27643-4 0.9002 to 0.9007 inch (22.8651 to 22.8778 mm)	120-013-4A 1.0285 to 1.0295 inches (26.1239 to 26.1493 mm)	Ring Stake T101873-13	

Table 9-5. Bearing and Sleeve Replacement Data (Cont)

MODEL	COMPONENT	BEARING P/N AND HOLE (BORE) SIZE FOR BEARING	SLEEVE P/N AND HOLE (BORE) SIZE FOR SLEEVE	TYPE STAKE AND TOOL NUMBER	NOTES
214ST	214-001-779	MS27641-5 0.8113 to 0.8118 inch (20.6070 to 20.6197 mm)	None	Not Staked	
214ST	214-001-783	MS27643-4 0.9002 to 0.9007 inch (22.8651 to 22.8778 mm)	120-013-4A 1.0285 to 1.0295 inches (26.1239 to 26.1493 mm)	Ring Stake T101873-13	
214ST	214-001-784	MS27640-4 0.9002 to 0.9007 inch (22.8651 to 22.8778 mm)	120-011-4A 1.0285 to 1.0295 inches (26.1239 to 26.1493 mm)	Ring Stake T101873-13	
214ST	214-001-788	MS27643-4 0.9002 to 0.9007 inch (22.8651 to 22.8778 mm)	120-013-4A 1.0285 to 1.0295 inches (26.1239 to 26.1493 mm)	Ring Stake T101873-13	
		MS27647-4 0.7488 to 0.7493 inch (19.0195 to 19.0322 mm)	120-015-4KA 0.8655 to 0.8665 inch (21.9800 to 22.0100 mm)	Ring Stake T101873-3	
214ST	214-001-789	MS27643-4 0.9002 to 0.9007 inch (22.8651 to 22.8778 mm)	120-013-4A 1.0285 to 1.0295 inches (26.1239 to 26.1493 mm)	Ring Stake T101873-13	
		MS27647-5 0.8738 to 0.8743 inch (22.1945 to 22.2072 mm)	120-015-5A 0.999 to 1.000 inch (25.375 to 25.400 mm)	Ring Stake T101873-11	
214ST	214-001-792	MS27647-6 1.0613 to 1.0618 inches (26.9570 to 26.9697 mm)	120-015-6A 1.1865 to 1.1875 inches (30.1371 to 30.1625 mm)	Ring Stake T101873-15	

Table 9-5. Bearing and Sleeve Replacement Data (Cont)







MODEL	COMPONENT	BEARING P/N AND HOLE (BORE) SIZE FOR BEARING	SLEEVE P/N AND HOLE (BORE) SIZE FOR SLEEVE	TYPE STAKE AND TOOL NUMBER	NOTES
214ST	214-001-792	MS27645-4A 0.7488 to 0.7493 inch (19.0195 to 19.0322 mm)	120-012-4A 0.8655 to 0.8665 inch (21.9837 to 22.0091 mm)	Ring Stake T101873-3	
214ST	214-001-794	MS27641-4 0.7488 to 0.7493 inch (19.0195 to 19.0322 mm)	None	Not Staked	
214B	214-001-909	Refer to BHT-214B-IPB and BHT- 214B-CR&O			
214B	214-001-912	209-001-051-001 0.6562 to 0.6567 inch (16.6675 to 16.6802 mm)	None	Anvil Stake T102095-3	
214B	214-001-914	MS27643-5 1.2488 to 1.2498 inches (31.7195 to 31.7449 mm)	120-013-5A 1.3740 to 1.3750 inches (34.9000 to 34.9300 mm)	Ring Stake T101873-19	
		MS27643-4 0.9002 to 0.9007 inch (22.8651 to 22.8778 mm)	120-013-4A 1.0285 to 1.0295 inches (26.1239 to 26.1493 mm)	Ring Stake T101873-13	
		MS27647-5 0.8738 to 0.8743 inch (22.1945 to 22.2072 mm)	120-015-5A 0.999 to 1.000 inch (25.375 to 25.400 mm)	Ring Stake T101873-11	
214B	214-001-915	MS27643-5 1.2488 to 1.2493 inches (31.7195 to 31.7322 mm)	120-013-5A 1.3740 to 1.3750 inches (34.8996 to 34.9250 mm)	Ring Stake T101873-19	

Table 9-5. Bearing and Sleeve Replacement Data (Cont)

MODEL	COMPONENT	BEARING P/N AND HOLE (BORE) SIZE FOR BEARING	SLEEVE P/N AND HOLE (BORE) SIZE FOR SLEEVE	TYPE STAKE AND TOOL NUMBER	NOTES
		214-001-093-003 0.8655 to 0.8665 inch (21.9837 to 22.0091 mm)	None	Ring Stake T101873-3	
		MS27643-4 0.9002 to 0.9007 inch (22.8651 to 22.8778 mm)	120-013-4A 1.0285 to 1.0295 inches (26.1239 to 26.1493 mm)	Ring Stake T101873-13	
214B	214-001-916	MS27643-4 0.9002 to 0.9007 inch (22.8651 to 22.8778 mm)	120-013-4A 1.0285 to 1.0295 inches (26.1239 to 26.1493 mm)	Ring Stake T101873-13	
		MS27643-5 1.2488 to 1.2493 inches (31.7195 to 31.7322 mm)	120-013-5A 1.3740 to 1.3750 inches (34.8996 to 34.9250 mm)	Ring Stake T101873-19	
		214-001-093-009	Replacement not authorized		
214ST 214B	214-001-918	209-010-459-001 1.8745 to 1.8750 inches (47.6123 to 47.6250 mm)	Sleeve bonded to bearing	Ring Stake T102015-5	
214B	214-001-920	MS27643-5 1.2488 to 1.2493 inches (31.7195 to 31.7322 mm)	120-013-5A 1.3740 to 1.3750 inches (34.8996 to 34.9250 mm)	Ring Stake T101873-19	
214B	214-001-931	209-001-051-001 0.6551 to 0.6556 inch (16.6395 to 16.6522 mm)	None	Anvil Stake T102095-3	
		MS27647-4 0.7488 to 0.7493 inch (19.0195 to 19.0322 mm)	120-015-4KA 0.8655 to 0.8665 inch (21.9837 to 22.0091 mm)	Ring Stake T101873-3	

Table 9-5. Bearing and Sleeve Replacement Data (Cont)













MODEL	COMPONENT	BEARING P/N AND HOLE (BORE) SIZE FOR BEARING	SLEEVE P/N AND HOLE (BORE) SIZE FOR SLEEVE	TYPE STAKE AND TOOL NUMBER	NOTES
214B	214-001-936	MS27641-4 0.7488 to 0.7493 inch (19.0195 to 19.0322 mm)	120-012-4A 0.8655 to 0.8665 inch (21.9837 to 22.0091 mm)	Ring Stake T101873-3	  
214ST	214-001-971	MS27643-4 0.9002 to 0.9007 inch (22.8651 to 22.8778 mm)	120-013-4A 1.0285 to 1.0295 inches (26.1239 to 26.1493 mm)	Ring Stake T101873-13	 
214ST	214-010-256	MS14103-8 0.9998 to 1.0003 inch (25.3949 to 25.4076 mm)	None	Roll Stake RST1010 	
214B	214-010-408	Refer to BHT-214B-CR&O			
214ST	214-010-494	Refer to BHT-214ST-CR&O			
214B	214-010-715	TGA104G or ALK4-86-1C1 0.6255 to 0.6260 inch (15.8877 to 15.9004 mm)	None	Roll Stake T101890 RST1002 	  
214B 214ST	214-010-719	MS27647-6G	Replacement not authorized. 214-010-720-001 (Bushing) I.D. 0.3750 to 0.3755 inch (9.5250 to 9.5377 mm) O.D. 0.4995 to 0.5000 inch (12.7873 to 12.7000 mm)		 

Table 9-5. Bearing and Sleeve Replacement Data (Cont)













MODEL	COMPONENT	BEARING P/N AND HOLE (BORE) SIZE FOR BEARING	SLEEVE P/N AND HOLE (BORE) SIZE FOR SLEEVE	TYPE STAKE AND TOOL NUMBER	NOTES
214B 214ST	214-010-721	MS28913-4B	Replacement not authorized.		
		MS27647-6G	Replacement not authorized.		
		214-010-736-001 0.6860 to 0.6870 inch (17.4244 to 17.4498 mm)	None	Not Staked	
214B	214-010-733	TGA108Y 1.0005 to 1.0010 inches (25.4127 to 25.4254 mm)	None	Roll Stake T101890 RST2017 	
214ST	214-010-815	ALK4-128-101 0.6255 to 0.6260 inch (15.8877 to 15.9004 mm)	None	Roll Stake RST1002 	
214B 214ST	214-010-850	AM2033-DHS 1.0005 to 1.0010 inches (25.4127 to 25.4254 mm)	None	Roll Stake RST2017 	
214B 214ST	214-010-851	AM2033-DHS 1.0005 to 1.0010 inches (25.4127 to 25.4254 mm)	None	Roll Stake RST2017 	
214B 214ST	214-011-802	214-011-819-101 1.4375 to 1.4380 inches (36.5125 to 36.5252 mm)	None	Roll Stake T101890 RST2015 	
214ST	214-011-811	214-011-811-103 0.6255 to 0.6260 inch (15.8877 to 15.9004 mm)	None	Roll Stake T101890 RST1002 	

Table 9-5. Bearing and Sleeve Replacement Data (Cont)









MODEL	COMPONENT	BEARING P/N AND HOLE (BORE) SIZE FOR BEARING	SLEEVE P/N AND HOLE (BORE) SIZE FOR SLEEVE	TYPE STAKE AND TOOL NUMBER	NOTES
214B	214-030-608	ADBY6V(L) 0.9049 to 0.9054 inch (22.9845 to 22.9972 mm)	None	Anvil Stake T101655-101	
214B	214-030-609	214-030-633-001 0.9050 to 0.9055 inch (22.9870 to 22.9997 mm)	None	Anvil Stake T103301-101	
214B	214-030-612	WSBS12ATC29-2Z 0.9062 to 0.9067 inch (23.0175 to 23.0302 mm)	None	Anvil Stake T101655-101	
214ST 214B	214-031-608	WSBS12ATC29-Z 0.9049 to 0.9054 inch (22.9845 to 22.9972 mm)	None	Anvil Stake T101655-101	
214ST	214-031-609	214-030-633-001 0.9050 to 0.9055 inch (22.9870 to 22.9997 mm)	None	Anvil Stake T103301-101	
214ST 214B	214-031-612	WSBS12ATC29-2Z 0.9062 to 0.9067 inch (23.0175 to 23.0302 mm)	None	Anvil Stake T101655-101	
214ST	214-031-613	WSBS12ATC29-2Z 0.9062 to 0.9067 inch (23.0175 to 23.0302 mm)	None	Anvil Stake T101655-101	
214ST	214-031-986	MS14101-3 0.5625 to 0.5635 inch (14.2875 to 14.3129 mm)	None	Roll Stake RST1000 	

Table 9-5. Bearing and Sleeve Replacement Data (Cont)

MODEL	COMPONENT	BEARING P/N AND HOLE (BORE) SIZE FOR BEARING	SLEEVE P/N AND HOLE (BORE) SIZE FOR SLEEVE	TYPE STAKE AND TOOL NUMBER	NOTES
214ST	214-032-923	MS14101-3 0.5625 to 0.5635 inch (14.2875 to 14.3129 mm)	None	Roll Stake RST1000 	 
214ST	214-032-954	MS14104-3 0.5616 to 0.5620 inch (14.2646 to 14.2748 mm)	None	Not Staked	
214ST	214-032-955	MS14104-3 0.5616 to 0.5620 inch (14.2646 to 14.2748 mm)	None	Not Staked	
214ST	214-032-963	MS14104-3 0.5616 to 0.5620 inch (14.2646 to 14.2748 mm)	None	Not Staked	
214ST	214-032-965	MS14104-3 0.5616 to 0.5620 inch (14.2646 to 14.2748 mm)	None	Not Staked	
214ST	214-052-102	MS14103-14 1.6248 to 1.6253 inches (41.2700 to 41.2826 mm)	None	Roll Stake RST1018 	 
		KPWD14P	None	Spanner KMT0140 	
214ST	214-052-148	MS14101-14 1.5623 to 1.5628 inches (39.6824 to 39.6951 mm)	None	Roll Stake RST1017 	 
214ST	214-052-149	MS14101-14 1.5623 to 1.5628 inches (39.6824 to 39.6951 mm)	None	Roll Stake RST1017 	 

Table 9-5. Bearing and Sleeve Replacement Data (Cont)











MODEL	COMPONENT	BEARING P/N AND HOLE (BORE) SIZE FOR BEARING	SLEEVE P/N AND HOLE (BORE) SIZE FOR SLEEVE	TYPE STAKE AND TOOL NUMBER	NOTES
214ST	214-052-161	MS14101-8 0.9998 to 1.0003 inches (25.4076 to 25.3949 mm)	None	Not Staked	
206L/ L1/L3/ L4 214ST 427	214-052-174-101	MS14101-6 0.8128 to 0.8123 inch (20.6451 to 20.6324 mm)	None	Roll Stake RST1006 	
206L/ L1/L3 L4 214ST 427	214-052-175-101	MS14101-6 0.8128 to 0.8123 inch (20.6451 to 20.6324 mm)	None	Roll Stake RST1006 	
214ST	214-052-175-105	MS14101-8 1.0003 to 0.9998 in. (25.4076 to 25.3949 mm)	None	Roll Stake RST1009 	
214B 214ST	214-052-200	MS14103-6 0.8125 to 0.8130 inch (20.6375 to 20.6502 mm)	None	Roll Stake RST1006 	
214ST	214-060-153	VTB03490 or P21320 0.8113 to 0.8118 inch (20.6070 to 20.6197 mm)	None	Roll Stake RST1006 	
		VTB03500 or P21340 0.9985 to 0.9993 inch (25.3619 to 25.3822 mm)	None	Roll Stake RST1009 	
214ST	214-060-157	VTB03490 or P21320 0.8113 to 0.8118 inch (20.6070 to 20.6197 mm)	None	Roll Stake RST1006 	

Table 9-5. Bearing and Sleeve Replacement Data (Cont)

















MODEL	COMPONENT	BEARING P/N AND HOLE (BORE) SIZE FOR BEARING	SLEEVE P/N AND HOLE (BORE) SIZE FOR SLEEVE	TYPE STAKE AND TOOL NUMBER	NOTES
214ST	214-060-207	VTB03490 0.8115 to 0.8120 inch (20.6121 to 20.6248 mm)	None	Roll Stake RST1006 	
214ST	214-060-210	VTB03490 0.8115 to 0.8120 inch (20.6121 to 20.6248 mm)	None	Roll Stake RST1006 	
214ST	214-060-211	VTB03500 or P21340 0.9990 to 0.9995 inch (25.3746 to 25.3873 mm)	None	Roll Stake RST1009 	
214ST	214-060-217	VTB03490 0.8115 to 0.8120 inch (20.6121 to 20.6248 mm)	None	Roll Stake RST1006 	
214ST	214-060-303	MS27645-4A 0.7488 to 0.7493 inch (19.0195 to 19.0322 mm)	120-012-4A 0.8655 to 0.8665 inch (21.9837 to 22.0091 mm)	Ring Stake T101873-3	 
214ST	214-060-304	MS27645-4A 0.7488 to 0.7493 inch (19.0195 to 19.0322 mm)	120-012-4A 0.8655 to 0.8665 inch (21.9837 to 22.0091 mm)	Ring Stake T101873-3	 
214ST	214-060-334	MS27645-6A 0.8738 to 0.8743 inch (22.1945 to 22.2072 mm)	120-012-6A 0.999 to 1.000 inch (25.375 to 25.400 mm)	Ring Stake T101873-9	 
214ST	214-060-335	MS27645-6A 0.8738 to 0.8743 inch (22.1945 to 22.2072 mm)	120-012-6A 0.999 to 1.000 inch (25.375 to 25.400 mm)	Ring Stake T101873-9	 

Table 9-5. Bearing and Sleeve Replacement Data (Cont)

MODEL	COMPONENT	BEARING P/N AND HOLE (BORE) SIZE FOR BEARING	SLEEVE P/N AND HOLE (BORE) SIZE FOR SLEEVE	TYPE STAKE AND TOOL NUMBER	NOTES
214B	214-060-730	MS27647-4 0.7488 to 0.7493 inch (19.0195 to 19.0322 mm)	120-015-4KA 0.8655 to 0.8665 inch (21.9837 to 22.0091 mm)	Ring Stake T101873-3	
214B	214-060-731	MS27647-4 0.7488 to 0.7493 inch (19.0195 to 19.0322 mm)	120-015-4KA 0.8655 to 0.8665 inch (21.9837 to 22.0091 mm)	Ring Stake T101873-3	
214B	214-060-732	MS27647-4 0.7488 to 0.7493 inch (19.0195 to 19.0322 mm)	120-015-4KA 0.8655 to 0.8665 inch (21.9837 to 22.0091 mm)	Ring Stake T101873-3	
214B	214-060-733	MS27647-4 0.7488 to 0.7493 inch (19.0195 to 19.0322 mm)	120-015-4KA 0.8655 to 0.8665 inch (21.9837 to 22.0091 mm)	Ring Stake T101873-3	
214B	214-060-742	MS27647-4A 0.6238 to 0.6243 inch (15.8445 to 15.8572 mm)	120-015-4K2A 0.7480 to 0.7490 inch (19.0000 to 19.0200 mm)	Ring Stake T102095-1	
214B	214-060-745	MS27645-10 1.9348 to 1.9358 inches (49.1439 to 49.1693 mm)	120-011-11A 2.0615 to 2.0625 inches (52.3621 to 52.3875 mm)	Ring Stake	
214B	214-060-758	MS20201-KP3A 0.6238 to 0.6243 inch (15.8445 to 15.8572 mm)	None	Segment Stake	
214B	214-060-770	Refer to BHT-214B-CR&O			
214B	214-060-781	MS27647-4 0.7488 to 0.7493 inch (19.0195 to 19.0322 mm)	120-015-4KA 0.8655 to 0.8665 inch (21.9837 to 22.0091 mm)	Ring Stake T101873-3	

Table 9-5. Bearing and Sleeve Replacement Data (Cont)















MODEL	COMPONENT	BEARING P/N AND HOLE (BORE) SIZE FOR BEARING	SLEEVE P/N AND HOLE (BORE) SIZE FOR SLEEVE	TYPE STAKE AND TOOL NUMBER	NOTES
214ST	214-061-878	MS14101-4 0.6562 to 0.6567 inch (16.6675 to 16.6802 mm)	None	Roll Stake RST1003 	
214ST	214-061-879	MS14101-4 0.6562 to 0.6567 inch (16.6675 to 16.6802 mm)	None	Roll Stake RST1003 	
214ST	214-061-883	MS14103-3 0.6238 to 0.6243 inch (15.8445 to 15.8572 mm)	None	Roll Stake RST1001 	
214ST	214-061-884	MS14101-4 0.6562 to 0.6567 inch (16.6675 to 16.6802 mm)	None	Roll Stake RST1003 	
214ST	214-061-887	MS14103-3 0.6238 to 0.6243 inch (15.8445 to 15.8572 mm)	None	Roll Stake RST1001 	
214B 214ST	214-352-200	MS14103-6 0.8130 to 0.8125 inch (20.6502 to 20.6375 mm)	None	Roll Stake RST1006 	
222 230 430	222-001-141	MS27647-4 0.7488 to 0.7493 inch (19.0195 to 19.0322 mm)	120-015-4KA 0.8665 inch (22.0091 mm) max. dia.	Ring Stake T101873-3	 
222 230 430	222-001-252	MS27643-4 0.9002 to 0.9007 inch (22.8651 to 22.8778 mm)	120-013-4A 1.0295 inches (26.1493 mm) max. dia.	Ring Stake T101873-13	 

Table 9-5. Bearing and Sleeve Replacement Data (Cont)





















MODEL	COMPONENT	BEARING P/N AND HOLE (BORE) SIZE FOR BEARING	SLEEVE P/N AND HOLE (BORE) SIZE FOR SLEEVE	TYPE STAKE AND TOOL NUMBER	NOTES
222 230 430	222-001-256	MS14101-4 0.6556 inch (16.6522 mm) max. dia.	None	Roll Stake RST1003 	 
222 230 430	222-001-283	MS27643-4 0.9002 to 0.9007 inch (22.8651 to 22.8778 mm)	120-013-4A 1.0295 inches (26.1493 mm) max. dia.	Ring Stake T101873-13	 
222 230 430	222-001-286	MS27643-4 0.9002 to 0.9007 inch (22.8651 to 22.8778 mm)	120-013-4A 1.0295 inches (26.1493 mm) max. dia.	Ring Stake T101873-13	 
222 230 430	222-001-291	MS27643-4 0.9002 to 0.9007 inch (22.8651 to 22.8778 mm)	120-013-4A 1.0295 inches (26.1493 mm) max. dia.	Ring Stake T101873-13	 
222 230	222-001-292	209-001-051-1 0.6567 inch (16.6802 mm) max. dia.	None	Anvil Stake T102095-3 or RST2011 	 
222 230 430	222-001-293	MS27646-41 1.501 inches (38.125 mm) max. dia.	None	None	
222 230 430	222-001-294	MS27647-5 0.8738 to 0.8743 inch (22.1945 to 22.2072 mm)	120-015-5A 1.000 inch (25.400 mm) max. dia.	Ring Stake T101873-11	 
		MS27643-4 0.9002 to 0.9007 inch (22.8651 to 22.8778 mm)	120-013-4A 1.0295 inches (26.1493 mm) max. dia.	Ring Stake T101873-13	 
		209-001-051-001 0.6567 inch (16.6802 mm) max. dia.	None	Anvil Stake T102095-3 or RST2011 	 

Table 9-5. Bearing and Sleeve Replacement Data (Cont)















MODEL	COMPONENT	BEARING P/N AND HOLE (BORE) SIZE FOR BEARING	SLEEVE P/N AND HOLE (BORE) SIZE FOR SLEEVE	TYPE STAKE AND TOOL NUMBER	NOTES
222 230 430	222-001-296	209-001-051-001 0.6567 inch (16.6802 mm) max. dia.	None	Anvil Stake T102095-3 or RST2011 	 
222	222-001-308	MS27643-4 0.9002 to 0.9007 inch (22.8651 to 22.8778 mm)	120-013-4A 1.0295 inches (26.1493 mm) max. dia.	Ring Stake T101873-13	 
222 230 430	222-001-314	MS27643-4 0.9002 to 0.9007 inch (22.8651 to 22.8778 mm)	120-013-4A 1.0295 inches (26.1493 mm) max. dia.	Ring Stake T101873-13	 
		MS27647-4 0.7488 to 0.7493 inch (19.0195 to 19.0322 mm)	120-015-4KA 0.8665 inch (22.0091 mm) max. dia.	Ring Stake T101873-3	 
222 230 430	222-001-328	MS27641-8 1.1238 to 1.1243 inches (28.5445 to 28.5512 mm)	120-012-8A 1.250 inches (31.750 mm) max. dia.	Ring Stake T101873-17	 
222 230 430	222-001-353	MS27640-4 0.9002 to 0.9007 inch (22.8651 to 22.8778 mm)	120-011-4A 1.0295 inches (26.1493 mm) max. dia.	Ring Stake T101873-13	 
222 230 430	222-001-355	MS27646-43 2.001 inches (50.825 mm) max. dia.	None	None	
222 230 430	222-001-358	MS27646-43 2.001 inches (50.825 mm) max. dia.	None	None	

Table 9-5. Bearing and Sleeve Replacement Data (Cont)









MODEL	COMPONENT	BEARING P/N AND HOLE (BORE) SIZE FOR BEARING	SLEEVE P/N AND HOLE (BORE) SIZE FOR SLEEVE	TYPE STAKE AND TOOL NUMBER	NOTES
222 230 430	222-001-360	MS27664-5/ DPP5W/FS464 1.2488 to 1.2493 inches (31.7195 to 31.7322 mm)	120-014-5A 1.3750 inches (34.9250 mm) max. dia.	Ring Stake T101873-19	
222 230 430	222-001-368	MS27643-4 0.9002 to 0.9007 inch (22.8651 to 22.8778 mm)	120-013-4A 1.0295 inches (26.1493 mm) max. dia.	Ring Stake T101873-13	
222 230 430	222-001-369	MS27646-41 1.501 inches (38.125 mm) max. dia.	None	None	
222	222-001-377	MS27641-4 0.7488 to 0.7493 inch (19.0195 to 19.0322 mm)	120-012-4A 0.8665 inch (22.0091 mm) max. dia.	Ring Stake T101873-3	
		MS27641-4 0.7488 to 0.7493 inch (19.0195 to 19.0322 mm)	None	None	
222 230	222-001-382	MS27643-4 0.9002 to 0.9007 inch (22.8651 to 22.8778 mm)	120-013-4A 1.0295 inches (26.1493 mm) max. dia.	Ring Stake T101873-13	
		MS27647-5 0.8738 to 0.8743 inch (22.1945 to 22.2072 mm)	120-015-5A 1.000 inch (25.400 mm) max. dia.	Ring Stake T101873-11	
222 230	222-001-383	MS27643-4 0.9002 to 0.9007 inch (22.8651 to 22.8778 mm)	120-013-4A 1.0295 inches (26.1493 mm) max. dia.	Ring Stake T101873-13	

Table 9-5. Bearing and Sleeve Replacement Data (Cont)









MODEL	COMPONENT	BEARING P/N AND HOLE (BORE) SIZE FOR BEARING	SLEEVE P/N AND HOLE (BORE) SIZE FOR SLEEVE	TYPE STAKE AND TOOL NUMBER	NOTES
		MS27647-5 0.8738 to 0.8743 inch (22.1945 to 22.2072 mm)	120-015-5A 1.000 inch (25.400 mm) max. dia.	Ring Stake T101873-11	
222 230	222-001-402	MS27643-4 0.9002 to 0.9007 inch (22.8651 to 22.8778 mm)	120-013-4A 1.0295 inches (26.1493 mm) max. dia.	Ring Stake T101873-13	
		MS27647-5 0.8738 to 0.8743 inch (22.1945 to 22.2072 mm)	120-015-5A 1.000 inch (25.400 mm) max. dia.	Ring Stake T101873-11	
222 230 430	222-001-403	MS27641-4 0.7493 inch (19.0322 mm) max. dia.	None	None	
		MS27641-4 0.7505 inch (19.0627 mm) max. dia.	None	None	
		MS27643-4 0.9002 to 0.9007 inch (22.8651 to 22.8778 mm)	120-013-4A 1.0295 inches (26.1493 mm) max. dia.	Ring Stake T101873-13	
222 230 430	222-001-407	MS27643-4 0.9002 to 0.9007 inch (22.8651 to 22.8778 mm)	120-013-4A 1.0295 inches (26.1493 mm) max. dia.	Ring Stake T101873-13	
222 230 430	222-001-434	MS27645-6A 0.8760 inch (22.2504 mm) max. dia.	None	None	
222 230 430	222-001-435	MS27645-6A 0.8760 inch (22.2504 mm) max. dia.	None	None	

Table 9-5. Bearing and Sleeve Replacement Data (Cont)











MODEL	COMPONENT	BEARING P/N AND HOLE (BORE) SIZE FOR BEARING	SLEEVE P/N AND HOLE (BORE) SIZE FOR SLEEVE	TYPE STAKE AND TOOL NUMBER	NOTES
222 230 430	222-001-504	MS27643-4 0.9002 to 0.9007 inch (22.8651 to 22.8778 mm)	120-013-4A 1.0295 inches (26.1493 mm) max. dia.	Ring Stake T101873-13	
		MS27647-4 0.7488 to 0.7493 inch (19.0195 to 19.0322 mm)	120-015-4KA 0.8665 inch (22.0091 mm) max. dia.	Ring Stake T101873-3	
222 230	222-001-513	209-001-051-001 0.6567 inch (16.6802 mm) max. dia.	None	Anvil Stake T102095-3 or RST2011 	
222 230 430	222-001-516	MS27647-4 0.7488 to 0.7493 inch (19.0195 to 19.0322 mm)	120-015-4KA 0.8665 inch (22.0091 mm) max. dia.	Ring Stake T101873-3	
222 230 430	222-001-521	MS27643-4 0.9002 to 0.9007 inch (22.8651 to 22.8778 mm)	120-013-4A 1.0295 inches (26.1493 mm) max. dia.	Ring Stake T101873-13	
222 230 430	222-001-522	MS27646-41 1.501 inches (38.125 mm) max. dia.	None	None	
222	222-001-523	MS27643-4 0.9002 to 0.9007 inch (22.8651 to 22.8778 mm)	120-013-4A 1.0295 inches (26.1493 mm) max. dia.	Ring Stake T101873-13	
		MS27647-5 0.8738 to 0.8743 inch (22.1945 to 22.2072 mm)	120-015-5A 1.000 inch (25.400 mm) max. dia.	Ring Stake T101873-11	
222 230 430	222-001-524	209-001-051-001 0.6567 inch (16.6802 mm) max. dia.	None	Anvil Stake T102095-3 or RST2011 	

Table 9-5. Bearing and Sleeve Replacement Data (Cont)









MODEL	COMPONENT	BEARING P/N AND HOLE (BORE) SIZE FOR BEARING	SLEEVE P/N AND HOLE (BORE) SIZE FOR SLEEVE	TYPE STAKE AND TOOL NUMBER	NOTES
222 230 430	222-001-528	MS27641-4 0.7488 to 0.7493 inch (19.0195 to 19.0322 mm)	120-012-4A 0.8665 inch (22.0091 mm) max. dia.	Ring Stake T101873-3	
222 230	222-001-530	MS27641-5 0.8130 inch (20.6502 mm) max. dia.	None	None	
222 230 430	222-001-706	MS27643-4 0.9002 to 0.9007 inch (22.8651 to 22.8778 mm)	120-013-4A 1.0295 inches (26.1493 mm) max. dia.	Ring Stake T101873-13	
		MS27647-4 0.7488 to 0.7493 inch (19.0195 to 19.0322 mm)	120-015-4KA 0.8665 inch max. dia. (22.0091 mm)	Ring Stake T101873-3	
222 230 430	222-001-711	MS27643-4 0.9002 to 0.9007 inch (22.8651 to 22.8778 mm)	120-013-4A 1.0295 inches (26.1493 mm) max. dia.	Ring Stake T101873-13	
		MS27641-4 0.7488 to 0.7493 inch (19.0195 to 19.0322 mm)	None	None	
222 230 430	222-001-713	MS27643-4 0.9002 to 0.9007 inch (22.8651 to 22.8778 mm)	120-013-4A 1.0295 inches (26.1493 mm) max. dia.	Ring Stake T101873-13	
		MS27641-4 0.7505 inch max. dia. (19.0322 mm)	None	None	
	222-001-713	MS27641-4 0.7505 inch max. dia. (19.0322 mm)	None	None	

Table 9-5. Bearing and Sleeve Replacement Data (Cont)









MODEL	COMPONENT	BEARING P/N AND HOLE (BORE) SIZE FOR BEARING	SLEEVE P/N AND HOLE (BORE) SIZE FOR SLEEVE	TYPE STAKE AND TOOL NUMBER	NOTES
222 230 430	222-001-727	MS27647-4 0.7488 to 0.7493 inch (19.0195 to 19.0322 mm)	120-015-4KA 0.8665 inch (22.0091 mm) max. dia.	Ring Stake T101873-3	
		MS27643-4 0.9002 to 0.9007 inch (22.8651 to 22.8778 mm)	120-013-4A 1.0295 inches (26.1493 mm) max. dia.	Ring Stake T101873-13	
222 230 430	222-001-734	MS27643-4 0.9002 to 0.9007 inch (22.8651 to 22.8778 mm)	120-013-4A 1.0295 inches (26.1493 mm) max. dia.	Ring Stake T101873-13	
		MS27647-4 0.7488 to 0.7493 inch (19.0195 to 19.0322 mm)	120-015-4KA 0.8665 inch (22.0091 mm) max. dia.	Ring Stake T101873-3	
222 230 430	222-001-736	MS27643-4 0.9002 to 0.9007 inch (22.8651 to 22.8778 mm)	120-013-4A 1.0295 inches (26.1493 mm) max. dia.	Ring Stake T101873-13	
		MS27647-4 0.7488 to 0.7493 inch (19.0195 to 19.0322 mm)	120-015-4KA 0.8665 inch (22.0091 mm) max. dia.	Ring Stake T101873-3	
222 230 430	222-001-740	MS27647-5 0.8738 to 0.8743 inch (22.1945 to 22.2072 mm)	120-015-5A 1.000 inch (25.400 mm) max. dia.	Ring Stake T101873-11	
222 230 430	222-001-741	MS27643-4 0.9002 to 0.9007 inch (22.8651 to 22.8778 mm)	120-013-4A 1.0295 inches (26.1493 mm) max. dia.	Ring Stake T101873-13	

Table 9-5. Bearing and Sleeve Replacement Data (Cont)









MODEL	COMPONENT	BEARING P/N AND HOLE (BORE) SIZE FOR BEARING	SLEEVE P/N AND HOLE (BORE) SIZE FOR SLEEVE	TYPE STAKE AND TOOL NUMBER	NOTES
		MS27647-6 1.0613 to 1.0618 inches (26.9570 to 26.9697 mm)	120-015-6A 1.1875 inches (30.1625 mm) max. dia.	Ring Stake T101873-15	
222 230 430	222-001-748	MS27645-4A 0.7488 to 0.7493 inch (19.0195 to 19.0322 mm)	120-012-4A 0.8665 inch (22.0091 mm) max. dia.	Ring Stake T101873-3	
		222-001-832-101 1.2500 inches (31.7500 mm) max. dia.	None	None	
222 230 430	222-001-768	MS27647-5 0.8738 to 0.8743 inch (22.1945 to 22.2072 mm)	120-015-5A 1.000 inch (25.400 mm) max. dia.	Ring Stake T101873-11	
222	222-001-774	MS27643-4 0.9002 to 0.9007 inch (22.8651 to 22.8778 mm)	120-013-4A 1.0295 inches (26.1493 mm) max. dia.	Ring Stake T101873-13	
		MS27641-4 0.7488 to 0.7493 inch (19.0195 to 19.0322 mm)	None	None	
222	222-001-777	MS27643-4 0.9002 to 0.9007 inch (22.8651 to 22.8778 mm)	120-013-4A 1.0295 inches (26.1493 mm) max. dia.	Ring Stake T101873-13	
222 230 430	222-001-816	MS27641-4 0.7505 inch (19.0627 mm) max. dia.	None	None	

Table 9-5. Bearing and Sleeve Replacement Data (Cont)









MODEL	COMPONENT	BEARING P/N AND HOLE (BORE) SIZE FOR BEARING	SLEEVE P/N AND HOLE (BORE) SIZE FOR SLEEVE	TYPE STAKE AND TOOL NUMBER	NOTES
222	222-001-818	MS27647-4A 0.6238 to 0.6243 inch (15.8445 to 15.8572 mm)	120-015-4K2A 0.7500 inch (19.0500 mm) max. dia.	Ring Stake T101873-3	 
222	222-001-819	MS27647-4 0.7488 to 0.7493 inch (19.0195 to 19.0322 mm)	120-015-4KA 0.8665 inch (22.0091 mm) max. dia.	Ring Stake T101873-3	 
222 230	222-010-415	222-310-461-001 1.6863 to 1.6868 inches (42.8320 to 42.8447 mm)	222-010-474-001 1.8463 inches (46.8960 mm) max. dia.	Roll Stake RST2071 	  
222	222-010-419-101 222-010-419-106	205-012-710-001 1.4380 inches (36.5252 mm) max. dia.	None	Roll Stake T101577	 
222 230	222-010-419-109 222-010-419-110	222-310-401-101 1.4380 inches (36.5252 mm) max. dia.	None	Roll Stake T101577	 
222 230 430	222-012-711	222-312-751-001 0.6255 inch (15.8877 mm) max. dia.	None	Roll Stake RST1002 	  
222 230 430	222-012-715	MS27643-4 0.9002 to 0.9007 inch (22.8651 to 22.8778 mm)	120-013-4A 1.0295 inches (26.1493 mm) max. dia.	Ring Stake T101873-13	 
		MS27641-4 0.7500 to 0.7505 inch (19.0500 to 19.0627 mm)	120-012-4A 0.8665 inch (22.0091 mm) max. dia.	Ring Stake T101873-3	 
		222-312-759-001 0.8110 to 0.8120 inch (20.5994 to 20.6248 mm)	None	None	

Table 9-5. Bearing and Sleeve Replacement Data (Cont)























MODEL	COMPONENT	BEARING P/N AND HOLE (BORE) SIZE FOR BEARING	SLEEVE P/N AND HOLE (BORE) SIZE FOR SLEEVE	TYPE STAKE AND TOOL NUMBER	NOTES
222	222-012-765	222-312-755 1.0000 to 1.0005 inches (25.4000 to 25.4127 mm)	None	Roll Stake RST2089 	  
		222-312-752 0.8130 to 0.8135 inch (20.6502 to 20.6629 mm)	None	Roll Stake RST2058 	  
222 230 430	222-031-206	MS27647-4 0.7488 to 0.7493 inch (19.0195 to 19.0322 mm)	120-015-4KA 0.8665 inch (22.0091 mm) max. dia.	Ring Stake T101873-3	 
		MS27645-3A 0.6238 to 0.6243 inch (15.8445 to 15.8572 mm)	120-011-3LA 0.7500 inch (19.0500 mm) max. dia.	Ring Stake	 
222 230 430	222-031-235	MS27646-43 2.0010 inches (50.8254 mm) max. dia.	None	None	
222 230	222-031-276	MS27647-6 1.0613 to 1.0618 inches (26.9570 to 26.9697 mm)	120-015-6S 1.1875 inches (30.1625 mm) max. dia.	Ring Stake T101873-15	 
222	222-031-619	222-330-625-001 or 222-330-619-101 0.9065 to 0.9070 inch (23.0251 to 23.0378 mm)	None	Roll Stake RST1034 	 
222	222-031-620	222-030-625-001 or 222-330-619-101 0.9065 to 0.9070 inch (23.0251 to 23.0378 mm)	None	Roll Stake RST1034 	  

Table 9-5. Bearing and Sleeve Replacement Data (Cont)



















MODEL	COMPONENT	BEARING P/N AND HOLE (BORE) SIZE FOR BEARING	SLEEVE P/N AND HOLE (BORE) SIZE FOR SLEEVE	TYPE STAKE AND TOOL NUMBER	NOTES
222 230	222-031-642	MS14101-7 0.9070 inch (23.0378 mm) max. dia.	None	Roll Stake RST1007 	  
222 230	222-031-662-105	LB6-1078-8-1 2.330 to 2.332 inches (59.182 to 59.233 mm)	None	Roll Stake 30155 	 
222 230	222-031-662-107	LB6-1078-9-1 1.994 to 1.942 inches (49.378 to 49.327 mm)	None	Roll Stake 30155 	 
222 230	222-060-204	MS27641-4 0.7505 inch (19.0627 mm) max. dia.	None	None	
222	222-060-226	MS27647-4 0.7488 to 0.7493 inch (19.0195 to 19.0322 mm)	120-015-4KA 0.8665 inch (22.0091 mm) max. dia.	Ring Stake T101873-3	 
222	222-060-239	MS27641-4 0.7505 inch (19.0627 mm) max. dia.	None	None	
222 230	222-060-706	MS27641-4 0.7505 inch (19.0627 mm) max. dia.	None	None	
222	222-060-717	MS27647-4 0.7488 to 0.7493 inch (19.0195 to 19.0322 mm)	120-015-4KA 0.8665 inch (22.0091 mm) max. dia.	Ring Stake T101873-3	 
222	222-060-726	MS27647-4 0.7488 to 0.7493 inch (19.0195 to 19.0322 mm)	120-015-4KA 0.8665 inch (22.0091 mm) max. dia.	Ring Stake T101873-3	 

Table 9-5. Bearing and Sleeve Replacement Data (Cont)































MODEL	COMPONENT	BEARING P/N AND HOLE (BORE) SIZE FOR BEARING	SLEEVE P/N AND HOLE (BORE) SIZE FOR SLEEVE	TYPE STAKE AND TOOL NUMBER	NOTES
222 230	222-060-790	MS27647-4 0.7488 to 0.7493 inch (19.0195 to 19.0322 mm)	120-015-4KA 0.8665 inch (22.0091 mm) max. dia.	Ring Stake T101873-3	 
222 230	222-331-617	222-330-625-001 or 222-330-619-101 0.9060 to 0.9065 inch (23.0124 to 23.0251 mm)	None	Roll Stake RST1034 	  
222 230	222-331-618	222-330-625-001 or 222-330-619-101 0.9060 to 0.9065 inch (23.0124 to 23.0251 mm)	None	Roll Stake RST1034 	  
222 230 430	222-336-001	MS14101-4 0.6560 to 0.6565 inch (16.6624 to 16.6751 mm)	None	Roll Stake T2682507-7  or RST1003 	  
		MS14101-5 0.7498 to 0.7503 inch (19.0449 to 19.0567 mm)	None	Roll Stake T2681903-1  or RST1005 	 
		MS14103-8 0.9998 to 1.0003 inches (25.3949 to 25.4076 mm)	None	Roll Stake T1231908-1  or RST1010 	 
		MS14103-10 1.1873 to 1.1878 inches (30.1574 to 30.1701 mm)	None	Roll Stake T675616-1  or RST1014 	  
222 230 430	222-382-001	212-010-782-101 1.1870 to 1.1885 inches (30.1498 to 30.1879 mm)	None	Roll Stake T101577	  

Table 9-5. Bearing and Sleeve Replacement Data (Cont)













MODEL	COMPONENT	BEARING P/N AND HOLE (BORE) SIZE FOR BEARING	SLEEVE P/N AND HOLE (BORE) SIZE FOR SLEEVE	TYPE STAKE AND TOOL NUMBER	NOTES
222 230 430	230-030-535-101 230-030-535-103	230-330-509-101 1.1248 to 1.1253 inches (28.5699 to 28.5826 mm)	None	Roll Stake RST2417 	 
230 430	230-061-808-101 230-061-808-102	MS14101-3 0.5625 to 0.5635 inch (14.2875 to 14.3129 mm)	None	Roll Stake RST1000 	
230 430	230-061-809-101 230-061-809-102	MS14101-3 0.5625 to 0.5635 inch (14.2875 to 14.3129 mm)	None	Roll Stake RST1000 	
222 230 430	230-312-001-101	230-312-001-103 0.8123 to 0.8128 inch (20.6324 to 20.6451 mm)	None	Roll Stake RST2058 	
		230-312-001-105 0.9373 to 0.9378 inch (23.8074 to 23.8201 mm)	None	Roll Stake RST2059 	
407	406-001-126	MS27646-40 1.3125 to 1.3135 inch (33.3375 to 33.3629 mm)	None	Not Staked	
407	406-001-704-101	MS27647-5 0.8738 to 0.8743 inch (22.1945 to 22.2072 mm)	120-015-5A 0.999 to 1.000 inch (25.3746 to 25.4000 mm)	Ring Stake T101873-11	
407	406-010-417-101	Refer to BHT-407-CR&O			
427	406-010-417-109	Refer to BHT-427-CR&O			

Table 9-5. Bearing and Sleeve Replacement Data (Cont)



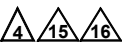



MODEL	COMPONENT	BEARING P/N AND HOLE (BORE) SIZE FOR BEARING	SLEEVE P/N AND HOLE (BORE) SIZE FOR SLEEVE	TYPE STAKE AND TOOL NUMBER	NOTES
407 427	406-010-432-101	Refer to BHT-407-CR&O and BHT-427-CR&O			
407 427	406-012-102-109	Refer to BHT-407-CR&O and BHT-427-CR&O			
407 427	407-001-050-101	MS14103-4 0.6245 to 0.6250 inch (15.8623 to 15.8750 mm)	None	Roll Stake	 
407	407-001-110-103	206-001-053-003 or 206-001-053-005 0.9062 to 0.9072 inch (23.0175 to 23.0429 mm)	None	Not Staked	
407	407-001-112-101	206-001-053-003 or 206-001-053-005 0.9062 to 0.9072 inch (23.0175 to 23.0429 mm)	None	Not Staked	
407 427	407-001-320-101	MKP4 0.9015 to 0.9019 inch (22.8981 to 22.9082 mm)	None	Not Staked	
		MKP4 0.9002 to 0.9007 inch (22.8651 to 22.8778 mm)	None	Roll Stake	
407 427	407-001-320-105 407-001-320-109	MKP4 0.9015 to 0.9019 inch (22.8981 to 22.9082 mm)	None	Not Staked	

Table 9-5. Bearing and Sleeve Replacement Data (Cont)







MODEL	COMPONENT	BEARING P/N AND HOLE (BORE) SIZE FOR BEARING	SLEEVE P/N AND HOLE (BORE) SIZE FOR SLEEVE	TYPE STAKE AND TOOL NUMBER	NOTES
		MKP4 0.9002 to 0.9007 inch (22.8651 to 22.8778 mm)	None	Roll Stake	
		206-301-051-101 0.9062 to 0.9067 inch (23.0175 to 23.0302 mm)	None	Anvil Stake	 
407	407-001-323-102	MS27647-5 0.8738 to 0.8743 inch (22.1945 to 22.2072 mm)	120-015-5A 0.999 to 1.000 inch (25.3746 to 25.4000 mm)	Ring Stake T101873-11	
407 427	407-001-323-102	MS27647-5 0.8738 to 0.8743 inch (22.1945 to 22.2072 mm)	120-015-5A 0.999 to 1.000 inch (25.3746 to 25.4000 mm)	Ring Stake T101873-11	
427	407-001-323-102	MS27647-5 0.8738 to 0.8743 inch (22.1945 to 22.2072 mm)	120-015-5A 0.999 to 1.000 inch (25.3746 to 25.4000 mm)	Ring Stake T101873-11	
407	407-001-324-105	MDW5/ MS27647-5 0.8738 to 0.8743 inch (22.1945 to 22.2072 mm)	120-015-5A 0.999 to 1.000 inch (25.3746 to 25.4000 mm)	Ring Stake T101873-11	
407	407-001-325-101	MS27647-5 0.8738 to 0.8743 inch (22.1945 to 22.2072 mm)	120-015-5A 0.999 to 1.000 inch (25.3746 to 25.4000 mm)	Ring Stake T101873-11	
		MS27645-4A 0.7488 to 0.7493 inch (19.0195 to 19.0322 mm)	120-012-4A 0.8655 to 0.8665 inch (21.9837 to 22.0091 mm)	Ring Stake T101873-3	

Table 9-5. Bearing and Sleeve Replacement Data (Cont)

MODEL	COMPONENT	BEARING P/N AND HOLE (BORE) SIZE FOR BEARING	SLEEVE P/N AND HOLE (BORE) SIZE FOR SLEEVE	TYPE STAKE AND TOOL NUMBER	NOTES
407	407-001-326-101	MS27647-5 0.8738 to 0.8743 inch (22.1945 to 22.2072 mm)	120-015-5A 0.999 to 1.000 inch (25.3746 to 25.4000 mm)	Ring Stake T101873-11	
407 427	407-001-520-101	209-001-051-001 0.6551 to 0.6556 inch (16.6395 to 16.6522 mm)	None	Roll Stake T102095-3	
		MS27641-5 0.8113 to 0.8118 inch (20.6070 to 20.6197 mm)	None	Not Staked	
		MS27641-5 0.8125 to 0.8130 inch (20.6375 to 20.6502 mm)	None	Not Staked	
407	407-001-521-101	209-001-051-001 0.6551 to 0.6556 inch (16.6395 to 16.6522 mm)	None	Roll Stake T102095-3	
		MS27641-4 0.7488 to 0.7493 inch (19.0195 to 19.0322 mm)	None	Not Staked	
		MS27641-4 0.7500 to 0.7505 inch (19.0500 to 19.0627 mm)	None	Not Staked	
407	407-001-522-101	209-001-051-001 0.6551 to 0.6556 inch (16.6395 to 16.6522 mm)	None	Roll Stake T102095-3	

Table 9-5. Bearing and Sleeve Replacement Data (Cont)









MODEL	COMPONENT	BEARING P/N AND HOLE (BORE) SIZE FOR BEARING	SLEEVE P/N AND HOLE (BORE) SIZE FOR SLEEVE	TYPE STAKE AND TOOL NUMBER	NOTES
		MS27641-4 0.7488 to 0.7493 inch (19.0195 to 19.0322 mm)	None	Not Staked	
		MS27641-4 0.7500 to 0.7505 inch (19.0500 to 19.0627 mm)	None	Not Staked	
427	407-001-522-105	209-001-051-001 0.6551 to 0.6556 inch (16.6395 to 16.6522 mm)	None	Roll Stake T102095-3	
		MS27641-4 0.7488 to 0.7493 inch (19.0195 to 19.0322 mm)	None	Not Staked	
		MS27641-4 0.7500 to 0.7505 inch (19.0500 to 19.0627 mm)	None	Not Staked	
407	407-001-523-101	MS27641-4 0.7488 to 0.7493 inch (19.0195 to 19.0322 mm)	None	Not Staked	
		MS27641-4 0.7500 to 0.7505 inch (19.0500 to 19.0627 mm)	None	Not Staked	
407	407-001-524-105	MS27647-5 0.8738 to 0.8743 inch (22.1945 to 22.2072 mm)	120-015-5A 0.999 to 1.000 inch (25.3746 to 25.4000 mm)	Ring Stake T101873-11	

Table 9-5. Bearing and Sleeve Replacement Data (Cont)





















MODEL	COMPONENT	BEARING P/N AND HOLE (BORE) SIZE FOR BEARING	SLEEVE P/N AND HOLE (BORE) SIZE FOR SLEEVE	TYPE STAKE AND TOOL NUMBER	NOTES
		206-010-470-101 0.9375 to 0.9385 inch (23.8125 to 23.8379 mm)	None	Roll Stake T101530-3 RST2010 	  
407	407-001-526-105	MS27647-6 1.0613 to 1.0618 inches (26.9570 to 26.9697 mm)	120-015-6A 1.1865 to 1.1875 inches (30.1371 to 30.1625 mm)	Ring Stake T101873-15	 
		206-010-470-101 0.9375 to 0.9385 inch (23.8125 to 23.8379 mm)	None	Roll Stake T101530-3 RST2010 	  
407	407-001-528-101	MS27647-6 1.0613 to 1.0618 inches (26.9570 to 26.9697 mm)	120-015-6A 1.1865 to 1.1875 inches (30.1371 to 30.1625 mm)	Ring Stake T101873-15	 
		206-010-470-101 0.9375 to 0.9385 inch (23.8125 to 23.8379 mm)	None	Roll Stake T101530-3 RST2010 	  
407	407-001-711-101	MS27641-4 0.7488 to 0.7493 inch (19.0195 to 19.0322 mm)	120-012-4A 0.8655 to 0.8665 inch (21.9837 to 22.0091 mm)	Ring Stake T101873-3	 
		MS27641-4 0.7488 to 0.7493 inch (19.0195 to 19.0322 mm)	None	Not Staked	
407	407-001-720-101	MS27647-4 or 20-082-4 0.7483 to 0.7493 inch (19.0068 to 19.0322 mm)	None	Roll Stake	 

Table 9-5. Bearing and Sleeve Replacement Data (Cont)









MODEL	COMPONENT	BEARING P/N AND HOLE (BORE) SIZE FOR BEARING	SLEEVE P/N AND HOLE (BORE) SIZE FOR SLEEVE	TYPE STAKE AND TOOL NUMBER	NOTES
407	407-001-723-101	MS27647-6 1.0613 to 1.0618 inches (26.9570 to 26.9697 mm)	120-015-6A 1.1865 to 1.1875 inch (30.1371 to 30.1625 mm)	Ring Stake T101873-15	
407	407-001-724-101 407-001-724-105	MS27647-5 0.8738 to 0.8743 inch (22.1945 to 22.2072 mm)	120-015-5A 0.999 to 1.000 inch (25.3746 to 25.4000 mm)	Ring Stake T101873-11	
407	407-001-725-101	MS27647-4 0.7488 to 0.7493 inch (22.8651 to 22.8778 mm)	120-015-4KA 0.8655 to 0.8665 inch (21.9837 to 22.0091 mm)	Ring Stake T101873-3	
407 427	407-001-731-101	MS27645-4A 0.7488 to 0.7493 inch (19.0195 to 19.0322 mm)	120-012-4A 0.8655 to 0.8665 inch (21.9837 to 22.0091 mm)	Ring Stake T101873-3	
407	407-001-732-101	MS27647-5 0.8738 to 0.8743 inch (22.1945 to 22.2072 mm)	120-015-5A 0.999 to 1.000 inch (25.3746 to 25.4000 mm)	Ring Stake T101873-11	
427	407-001-732-107 407-001-732-109	MS27647-5 0.8738 to 0.8743 inch (22.1945 to 22.2072 mm)	120-015-5A 0.999 to 1.000 inch (25.3746 to 25.4000 mm)	Ring Stake T101873-11	
412	412-001-300-105	MS27647-5 0.8738 to 0.8743 inch (22.1945 to 22.2072 mm)	120-015-5A 0.9990 to 1.0000 inch (25.3746 to 25.4000 mm)	Ring Stake T101873-11	
		MS27643-4 0.9002 to 0.9007 inch (22.8651 to 22.8778 mm)	120-013-4A 1.0285 to 1.0295 inches (26.1239 to 26.1493 mm)	Ring Stake T101873-13	

Table 9-5. Bearing and Sleeve Replacement Data (Cont)











MODEL	COMPONENT	BEARING P/N AND HOLE (BORE) SIZE FOR BEARING	SLEEVE P/N AND HOLE (BORE) SIZE FOR SLEEVE	TYPE STAKE AND TOOL NUMBER	NOTES
412	412-001-301-101	MS27643-4 0.9002 to 0.9007 inch (22.8651 to 22.8778 mm)	120-013-4A 1.0285 to 1.0295 inches (26.1239 to 26.1493 mm)	Ring Stake T101873-13	
412	412-001-306-101	MS27643-4 0.9002 to 0.9007 inch (22.8651 to 22.8778 mm)	120-013-4A 1.0285 to 1.0295 inches (26.1239 to 26.1493 mm)	Ring Stake T101873-13	
412	412-001-900-101	MS27643-4 0.9002 to 0.9007 inch (22.8651 to 22.8778 mm)	120-013-4A 1.0285 to 1.0295 inches (26.1239 to 26.1493 mm)	Ring Stake T101873-13	
412	412-010-405-101 412-010-405-107 412-010-405-109	412-010-427-101 1.3748 to 1.3753 inches (34.9200 to 34.9300 mm)	None	Roll Stake RST2128 	
412	412-010-448-101	412-010-427-101 1.3748 to 1.3753 inches (34.9200 to 34.9300 mm)	None	Roll Stake RST2128 	
205A-1 212 412	412-076-620	MS27647-5 0.8740 to 0.8745 inch (22.1996 to 22.2123 mm)	None	None	
412	412-310-400-101 412-310-400-103 412-310-400-105	412-310-400-107 1.3750 to 1.3755 inches (34.9300 to 34.9400 mm)	None	Roll Stake RST2345 	
427	427-001-021-101	406-310-403-101 1.029 to 1.030 inches (26.1366 to 26.1620 mm)	None	Roll Stake	

Table 9-5. Bearing and Sleeve Replacement Data (Cont)







MODEL	COMPONENT	BEARING P/N AND HOLE (BORE) SIZE FOR BEARING	SLEEVE P/N AND HOLE (BORE) SIZE FOR SLEEVE	TYPE STAKE AND TOOL NUMBER	NOTES
427	427-001-022-101	406-310-403-101 1.029 to 1.030 inches (26.1366 to 26.1620 mm)	None	Roll Stake	
427	427-001-120-101	MS27647-6 1.0613 to 1.0618 inches (26.9570 to 26.9697 mm)	None	Ring Stake	
427	427-001-138-115	MS27641-4 0.7490 to 0.7495 inch (19.0246 to 19.0373 mm)	None	Not Staked	
427	427-001-148-101	MS27641-4 0.7500 to 0.7505 inch (19.0500 to 19.0627 mm)	None	Not Staked	
427	427-001-168-101	MS27647-4A 0.6240 to 0.6245 inch (15.8496 to 15.8623 mm)	None	Ring Stake (One side)	
427	427-001-169-101	MS27647-4A 0.6240 to 0.6245 inch (15.8496 to 15.8623 mm)	None	Ring Stake (One side)	
427	427-001-323-101	MS27647-6 1.0613 to 1.0618 inches (26.9570 to 26.9697 mm)	120-015-6A 1.1865 to 1.1875 inches (30.1371 to 30.1625 mm)	Ring Stake T101873-15	
		209-001-051-001 0.6562 to 0.6567 inch (16.6675 to 16.6802 mm)	None	Roll Stake T102095-3	

Table 9-5. Bearing and Sleeve Replacement Data (Cont)

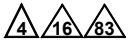











MODEL	COMPONENT	BEARING P/N AND HOLE (BORE) SIZE FOR BEARING	SLEEVE P/N AND HOLE (BORE) SIZE FOR SLEEVE	TYPE STAKE AND TOOL NUMBER	NOTES
427	427-001-520	MS27647-6 1.0613 to 1.0618 inches (26.9570 to 26.9697 mm)	120-015-6A 1.1865 to 1.1875 inches (30.1371 to 30.1625 mm)	Ring Stake T101873-15	
		206-010-470-101 0.9375 to 0.9385 inch (23.8125 to 23.8379 mm)	None	Roll Stake T101530-3 RST2010 	 
427	427-001-521	MS27647-6 1.0613 to 1.0618 inches (26.9570 to 26.9697 mm)	120-015-6A 1.1865 to 1.1875 inches (30.1371 to 30.1625 mm)	Ring Stake T101873-15	
		206-010-470-101 0.9375 to 0.9385 inch (23.8125 to 23.8379 mm)	None	Roll Stake T101530-3 RST2010 	 
427	427-001-522	MS27647-5 0.8738 to 0.8743 inch (22.1945 to 22.2072 mm)	120-015-5A 0.999 to 1.000 inch (25.3746 to 25.4000 mm)	Ring Stake T101873-11	
		206-010-470-101 0.9375 to 0.9385 inch (23.8125 to 23.8379 mm)	None	Roll Stake T101530-3 RST2010 	
427	427-001-535-101	MS27641-4 0.7488 to 0.7493 inch (19.0195 to 19.0322 mm)	None	Not Staked	
		MS27641-4 0.7500 to 0.7505 inch (19.0500 to 19.0627 mm)	None	Not Staked	

Table 9-5. Bearing and Sleeve Replacement Data (Cont)









MODEL	COMPONENT	BEARING P/N AND HOLE (BORE) SIZE FOR BEARING	SLEEVE P/N AND HOLE (BORE) SIZE FOR SLEEVE	TYPE STAKE AND TOOL NUMBER	NOTES
427	427-001-550-135	MS27645-4A 0.7488 to 0.7493 inch (19.0195 to 19.0322 mm)	120-012-4A 0.8655 to 0.8665 inch (21.9837 to 22.0091 mm)	Ring Stake T101873-3	
427	427-001-720-101	MS27643-4 0.9002 to 0.9007 inch (22.8651 to 22.8778 mm)	120-013-4A 1.0285 to 1.0295 inches (26.1239 to 26.1493 mm)	Ring Stake T101873-13	
		MS27647-4 0.7488 to 0.7493 inch (19.0195 to 19.0322 mm)	120-015-4KA 0.8652 to 0.8662 inch (21.9761 to 22.0015 mm)	Ring Stake T101873-3	
427	427-001-721-105	MS27647-5 0.8738 to 0.8743 inch (22.1945 to 22.2072 mm)	None	Roll Stake	
427	427-001-722-103	MS27643-4 0.9002 to 0.9007 inch (22.8651 to 22.8778 mm)	120-013-4A 1.0285 to 1.0295 inches (26.1239 to 26.1493 mm)	Ring Stake T101873-13	
427	427-001-723-101	MS27647-4 0.7488 to 0.7493 inch (19.0195 to 19.0322 mm)	120-015-4KA 0.8655 to 0.8665 inch (21.9837 to 22.0091 mm)	Ring Stake T101873-3	
427	427-001-725-101	MS27643-4 0.9002 to 0.9007 inch (22.8651 to 22.8778 mm)	120-013-4A 1.0285 to 1.0295 inches (26.1239 to 26.1493 mm)	Ring Stake T101873-13	
427	427-001-726-101	MS27647-5 0.8738 to 0.8743 inch (22.1945 to 22.2072 mm)	None	Roll Stake	

Table 9-5. Bearing and Sleeve Replacement Data (Cont)

MODEL	COMPONENT	BEARING P/N AND HOLE (BORE) SIZE FOR BEARING	SLEEVE P/N AND HOLE (BORE) SIZE FOR SLEEVE	TYPE STAKE AND TOOL NUMBER	NOTES
427	427-001-740-101	MS27646-41 1.5000 to 1.5010 inches (38.1000 to 38.1254 mm)	None	Not Staked	
427	427-010-208-101	430-310-205-103 1.3748 to 1.3753 inches (34.9200 to 34.9300 mm)	None	Roll Stake RST2936	
427	427-010-210-101	430-310-205-103 1.3748 to 1.3753 inches (34.9200 to 34.9300 mm)	None	Roll Stake RST2936	
429	427-010-210-105 427-010-210-109	430-310-205-105 1.3748 to 1.3759 inches (34.920 to 34.932 mm)	None	Roll Stake RST2936	
427	427-030-689-101	MS27647-5 0.8738 to 0.8743 inch (22.1945 to 22.2072 mm)	120-015-5A 0.999 to 1.000 inch (25.3746 to 25.4000 mm)	Ring Stake T101873-11	
429	429-001-721-101	MS14103-4 0.6248 to 0.6253 inch (15.8699 to 15.8826 mm)	None	Roll Stake	
		MS27647-4 0.7488 to 0.7493 inch (19.0195 to 19.0322 mm)	120-015-4KA 0.8655 to 0.8665 inch (21.9837 to 22.0091 mm)	Ring Stake T101873-3	
		MS14101-5A 0.7498 to 0.7503 inch (19.0449 to 19.0567 mm)	None	Roll Stake	

Table 9-5. Bearing and Sleeve Replacement Data (Cont)







MODEL	COMPONENT	BEARING P/N AND HOLE (BORE) SIZE FOR BEARING	SLEEVE P/N AND HOLE (BORE) SIZE FOR SLEEVE	TYPE STAKE AND TOOL NUMBER	NOTES
429	429-001-030-101	MS27643-4 0.9002 to 0.9007 inch (22.8651 to 22.8778 mm)	120-013-4A/ 1.0285 to 1.0295 inches (26.1239 to 26.1493 mm)	Ring Stake T101873-13	
429	429-001-031-101	MS27643-4 0.9002 to 0.9007 inch (22.8651 to 22.8778 mm)	120-013-4A/ 1.0285 to 1.0295 inches (26.1239 to 26.1493 mm)	Ring Stake T101873-13	
429	429-001-121-101	MS27643-4 0.9002 to 0.9007 inch (22.8651 to 22.8778 mm)	120-013-4A/ 1.0285 to 1.0295 inches (26.1239 to 26.1493 mm)	Ring Stake T101873-13	
		MS27641-5 0.8113 to 0.8118 inch (20.6070 to 20.6197 mm)	None	Not Staked	
		MS27641-5 0.8125 to 0.8130 inch (20.6375 to 20.6502 mm)	None	Not Staked	
429	429-001-122-101	MS27647-6 1.0613 to 1.0618 inches (26.9570 to 26.9697 mm)	120-015-6A 1.1865 to 1.1875 inches (30.1371 to 30.1625 mm)	Ring Stake T101873-15	
		MS27645-4A 0.7488 to 0.7493 inch (19.0195 to 19.0322 mm)	120-012-4A 0.8655 to 0.8665 inch (21.9837 to 22.0091 mm)	Ring Stake T101873-3	
429	429-001-124-101	MS27643-4 0.9002 to 0.9007 inch (22.8651 to 22.8778 mm)	120-013-4A/ 1.0285 to 1.0295 inches (26.1239 to 26.1493 mm)	Ring Stake T101873-13	

Table 9-5. Bearing and Sleeve Replacement Data (Cont)

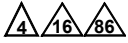
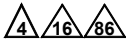
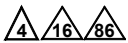







MODEL	COMPONENT	BEARING P/N AND HOLE (BORE) SIZE FOR BEARING	SLEEVE P/N AND HOLE (BORE) SIZE FOR SLEEVE	TYPE STAKE AND TOOL NUMBER	NOTES
429	429-001-124-101	MS27647-5 0.8738 to 0.8743 inch (22.1945 to 22.2072 mm)	120-015-5A 0.999 to 1.000 inch (25.3746 to 25.4000 mm)	Ring Stake T101873-11	
		MS27645-4A 0.7488 to 0.7493 inch (19.0195 to 19.0322 mm)	120-012-4A 0.8655 to 0.8665 inch (21.9837 to 22.0091 mm)	Ring Stake T101873-3	
429	429-001-315-105	MS27643-4 0.9002 to 0.9007 inch (22.8651 to 22.8778 mm)	120-013-4A/ 1.0285 to 1.0295 inches (26.1239 to 26.1493 mm)	Ring Stake T101873-13	
		MS27645-4A 0.7488 to 0.7493 inch (19.0195 to 19.0322 mm)	120-012-4A 0.8655 to 0.8665 inch (21.9837 to 22.0091 mm)	Ring Stake T101873-3	
429	429-001-317-101	MS27641-5 0.8113 to 0.8118 inch (20.6070 to 20.6197 mm)	None	Not Staked	
429	429-001-320-101	MS27643-4 0.9002 to 0.9007 inch (22.8651 to 22.8778 mm)	120-013-4A/ 1.0285 to 1.0295 inches (26.1239 to 26.1493 mm)	Ring Stake T101873-13	
		MS27641-5 0.8113 to 0.8118 inch (20.6070 to 20.6197 mm)	None	Not Staked	
		MS27641-5 0.8125 to 0.8130 inch (20.6375 to 20.6502 mm)	None	Not Staked	

Table 9-5. Bearing and Sleeve Replacement Data (Cont)









MODEL	COMPONENT	BEARING P/N AND HOLE (BORE) SIZE FOR BEARING	SLEEVE P/N AND HOLE (BORE) SIZE FOR SLEEVE	TYPE STAKE AND TOOL NUMBER	NOTES
429	429-001-321-101	MS27643-4 0.9002 to 0.9007 inch (22.8651 to 22.8778 mm)	120-013-4A/ 1.0285 to 1.0295 inches (26.1239 to 26.1493 mm)	Ring Stake T101873-13	
		MS27641-5 0.8113 to 0.8118 inch (20.6070 to 20.6197 mm)	None	Not Staked	
		MS27641-5 0.8125 to 0.8130 inch (20.6375 to 20.6502 mm)	None	Not Staked	
429	429-001-323-101	MS27643-4 0.9002 to 0.9007 inch (22.8651 to 22.8778 mm)	120-013-4A/ 1.0285 to 1.0295 inches (26.1239 to 26.1493 mm)	Ring Stake T101873-13	
		MS27647-5 0.8738 to 0.8743 inch (22.1945 to 22.2072 mm)	120-015-5A 0.999 to 1.000 inch (25.3746 to 25.4000 mm)	Ring Stake T101873-11	
		MS27645-4 0.9002 to 0.9007 inch (22.8651 to 22.8778 mm)	120-011-4A 1.0285 to 1.0295 inches (26.1239 to 26.1493 mm)	Ring Stake T101873-13	
429	429-001-324-101 429-001-324-102	MS27643-4 0.9002 to 0.9007 inch (22.8651 to 22.8778 mm)	120-013-4A/ 1.0285 to 1.0295 inches (26.1239 to 26.1493 mm)	Ring Stake T101873-13	
		MS27647-5 0.8738 to 0.8743 inch (22.1945 to 22.2072 mm)	120-015-5A 0.999 to 1.000 inch (25.3746 to 25.4000 mm)	Ring Stake T101873-11	

Table 9-5. Bearing and Sleeve Replacement Data (Cont)







MODEL	COMPONENT	BEARING P/N AND HOLE (BORE) SIZE FOR BEARING	SLEEVE P/N AND HOLE (BORE) SIZE FOR SLEEVE	TYPE STAKE AND TOOL NUMBER	NOTES
429	429-001-327-101	MS27643-4 0.9002 to 0.9007 inch (22.8651 to 22.8778 mm)	120-013-4A/ 1.0285 to 1.0295 inches (26.1239 to 26.1493 mm)	Ring Stake T101873-13	
		MS27647-5 0.8738 to 0.8743 inch (22.1945 to 22.2072 mm)	120-015-5A 0.999 to 1.000 inch (25.3746 to 25.4000 mm)	Ring Stake T101873-11	
		MS27645-4 0.9002 to 0.9007 inch (22.8651 to 22.8778 mm)	120-011-4A 1.0285 to 1.0295 inches (26.1239 to 26.1493 mm)	Ring Stake T101873-13	
429	429-001-328-101	MS27643-4 0.9002 to 0.9007 inch (22.8651 to 22.8778 mm)	120-013-4A/ 1.0285 to 1.0295 inches (26.1239 to 26.1493 mm)	Ring Stake T101873-13	
		MS27647-5 0.8738 to 0.8743 inch (22.1945 to 22.2072 mm)	120-015-5A 0.999 to 1.000 inch (25.3746 to 25.4000 mm)	Ring Stake T101873-11	
		MS27645-4 0.9002 to 0.9007 inch (22.8651 to 22.8778 mm)	120-011-4A 1.0285 to 1.0295 inches (26.1239 to 26.1493 mm)	Ring Stake T101873-13	
429	429-001-353-101	MS27641-5 0.8113 to 0.8118 inch (20.6070 to 20.6197 mm)	None	Not Staked	
429	429-001-520-101	MS27647-8 1.4363 to 1.4368 inches (36.4820 to 36.4947 mm)	120-015-8A 1.5625 to 1.5635 inches (39.6875 to 39.7129 mm)	Ring Stake	

Table 9-5. Bearing and Sleeve Replacement Data (Cont)



















MODEL	COMPONENT	BEARING P/N AND HOLE (BORE) SIZE FOR BEARING	SLEEVE P/N AND HOLE (BORE) SIZE FOR SLEEVE	TYPE STAKE AND TOOL NUMBER	NOTES
429	429-001-520-101	MS14101-6 0.8123 to 0.8128 inch (20.6324 to 20.6451 mm)	None	Roll Stake RST1006 	 
		206-010-470-101 0.9375 to 0.9385 inch (23.8125 to 23.8379 mm)	None	Roll Stake T101530-3 RST2010 	 
429	429-001-521-101	MS27647-8 1.4363 to 1.4368 inches (36.4820 to 36.4947 mm)	120-015-8A 1.5625 to 1.5635 inches (39.6875 to 39.7129 mm)	Ring Stake	
		MS14101-6 0.8123 to 0.8128 inch (20.6324 to 20.6451 mm)	None	Roll Stake RST1006 	 
429	429-001-522-101	MS27647-8 1.4363 to 1.4368 inches (36.4820 to 36.4947 mm)	120-015-8A 1.5625 to 1.5635 inches (39.6875 to 39.7129 mm)	Ring Stake	
		MS14101-6 0.8123 to 0.8128 inch (20.6324 to 20.6451 mm)	None	Roll Stake RST1006 	 
		206-010-470-101 0.9375 to 0.9385 inch (23.8125 to 23.8379 mm)	None	Roll Stake T101530-3 RST2010 	 
429	429-001-523-101	MS27646-41 1.5000 to 1.5010 inches (38.1000 to 38.1254 mm)	None	Not Staked	

Table 9-5. Bearing and Sleeve Replacement Data (Cont)

MODEL	COMPONENT	BEARING P/N AND HOLE (BORE) SIZE FOR BEARING	SLEEVE P/N AND HOLE (BORE) SIZE FOR SLEEVE	TYPE STAKE AND TOOL NUMBER	NOTES
429	429-001-525-101	MS27643-4 0.9002 to 0.9007 inch (22.8651 to 22.8778 mm)	120-013-4A/ 1.0285 to 1.0295 inches (26.1239 to 26.1493 mm)	Ring Stake T101873-13	
429	429-001-526-101	MS27643-4 0.9002 to 0.9007 inch (22.8651 to 22.8778 mm)	120-013-4A/ 1.0285 to 1.0295 inches (26.1239 to 26.1493 mm)	Ring Stake T101873-13	
429	429-001-527-101	MS27643-4 0.9002 to 0.9007 inch (22.8651 to 22.8778 mm)	120-013-4A/ 1.0285 to 1.0295 inches (26.1239 to 26.1493 mm)	Ring Stake T101873-13	
429	429-001-528-101	MS27643-4 0.9002 to 0.9007 inch (22.8651 to 22.8778 mm)	120-013-4A/ 1.0285 to 1.0295 inches (26.1239 to 26.1493 mm)	Ring Stake T101873-13	
429	429-001-530-101	MS27643-4 0.9002 to 0.9007 inch (22.8651 to 22.8778 mm)	120-013-4A/ 1.0285 to 1.0295 inches (26.1239 to 26.1493 mm)	Ring Stake T101873-13	
429	429-001-531-101	MS27643-4 0.9002 to 0.9007 inch (22.8651 to 22.8778 mm)	120-013-4A/ 1.0285 to 1.0295 inches (26.1239 to 26.1493 mm)	Ring Stake T101873-13	
429	429-001-532-101	MS27646-41 1.5000 to 1.5010 inches (38.1000 to 38.1254 mm)	None	Not Staked	
429	429-001-702-101	MS27643-4 0.9002 to 0.9007 inch (22.8651 to 22.8778 mm)	120-013-4A/ 1.0285 to 1.0295 inches (26.1239 to 26.1493 mm)	Ring Stake T101873-13	

Table 9-5. Bearing and Sleeve Replacement Data (Cont)

















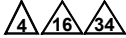































MODEL	COMPONENT	BEARING P/N AND HOLE (BORE) SIZE FOR BEARING	SLEEVE P/N AND HOLE (BORE) SIZE FOR SLEEVE	TYPE STAKE AND TOOL NUMBER	NOTES
429	429-001-702-101	MS27647-5 0.8738 to 0.8743 inch (22.1945 to 22.2072 mm)	120-015-5A 0.999 to 1.000 inch (25.3746 to 25.4000 mm)	Ring Stake T101873-11	
		MS27647-4 0.7488 to 0.7493 inch (19.0195 to 19.0322 mm)	120-015-4KA 0.8655 to 0.8665 inch (21.9837 to 22.0091 mm)	Ring Stake T101873-3	
429	429-001-711-101	MS27646-38 1.0610 to 1.0615 inches (26.9494 to 26.9621 mm)	None	Not Staked	
429	429-001-714-101	MS27646-38 1.0625 to 1.0630 inches (26.9875 to 27.0002 mm)	None	Not Staked	
429	429-001-720-101	MS27643-4 0.9002 to 0.9007 inch (22.8651 to 22.8778 mm)	120-013-4A/ 1.0285 to 1.0295 inches (26.1239 to 26.1493 mm)	Ring Stake T101873-13	
		MS27647-4 0.7488 to 0.7493 inch (19.0195 to 19.0322 mm)	120-015-4KA 0.8655 to 0.8665 inch (21.9837 to 22.0091 mm)	Ring Stake T101873-3	
429	429-001-721-101	MS14101-5A 0.7498 to 0.7503 inch (19.0449 to 19.0567 mm)	None	Roll Stake T2681903-1  or RST1005 	
		MS14103-4 0.6248 to 0.6253 inch (15.8699 to 15.8826 mm)	None	Roll Stake RST1002 	 

Table 9-5. Bearing and Sleeve Replacement Data (Cont)

MODEL	COMPONENT	BEARING P/N AND HOLE (BORE) SIZE FOR BEARING	SLEEVE P/N AND HOLE (BORE) SIZE FOR SLEEVE	TYPE STAKE AND TOOL NUMBER	NOTES
429	429-001-721-101	MS27647-4 0.7488 to 0.7493 inch (19.0195 to 19.0322 mm)	120-015-4KA 0.8655 to 0.8665 inch (21.9837 to 22.0091 mm)	Ring Stake T101873-3	
429	429-001-722-101	MS14103-4 0.6248 to 0.6253 inch (15.8699 to 15.8826 mm)	None	Roll Stake	
		MS27641-6 0.8750 to 0.8755 inch (22.2250 to 22.2377 mm)	None	Not Staked	
		MS27641-6 0.8738 to 0.8743 inch (22.1945 to 22.2072 mm)	None	Not Staked	
429	429-001-727-101	MS27643-4 0.9002 to 0.9007 inch (22.8651 to 22.8778 mm)	120-013-4A/ 1.0285 to 1.0295 inches (26.1239 to 26.1493 mm)	Ring Stake T101873-13	
		MS27647-4 0.7488 to 0.7493 inch (19.0195 to 19.0322 mm)	120-015-4KA 0.8655 to 0.8665 inch (21.9837 to 22.0091 mm)	Ring Stake T101873-3	
429	429-012-105-101	Refer to the BHT-429-CMM , Chapter 64			
430	430-010-204-101 430-010-204-103	430-310-201-101 1.9425 to 1.9430 inches (49.3395 to 49.3522 mm)	None	Roll Stake RST2940	

Table 9-5. Bearing and Sleeve Replacement Data (Cont)

MODEL	COMPONENT	BEARING P/N AND HOLE (BORE) SIZE FOR BEARING	SLEEVE P/N AND HOLE (BORE) SIZE FOR SLEEVE	TYPE STAKE AND TOOL NUMBER	NOTES
430	430-010-208-101 430-010-208-105	430-310-205-103 1.3748 to 1.3753 inches (34.9200 to 34.9300 mm)	None	Roll Stake RST2936  	  
430	430-010-209-101 430-010-209-103	430-310-207-101 0.9061 to 0.9066 inch (23.0149 to 23.0276 mm)	None	Roll Stake RST2941  	  
430	430-010-211-101 430-010-211-105	430-310-205-101 1.3748 to 1.3753 inches (34.9200 to 34.9300 mm)	None	Roll Stake RST2936  	  
430	430-010-212-101 430-010-212-103	430-310-206-101 1.0935 to 1.0940 inches (27.7749 to 27.7876 mm)	None	Roll Stake RST2938  	  
430	430-010-412-105 430-010-412-106	430-310-456-101 1.248 to 1.253 inches (31.6992 to 31.8262 mm)	None	Roll Stake RST2939  	   
430	430-010-433-101	430-310-456-101 1.248 to 1.253 inches (31.6992 to 31.8262 mm)	None	Roll Stake RST2939  	   
429 430	430-010-449-101	430-310-456-101 1.248 to 1.253 inches (31.6992 to 31.8262 mm)	None	Roll Stake RST2939  	   

NOTES:



DO NOT USE WATER-BORNE EPOXY PRIMER COATING (C-246) FOR WET INSTALLATIONS.

Table 9-5. Bearing and Sleeve Replacement Data (Cont)**NOTES (CONT):**

- △₁ On fixed control part, install bearing/bearing sleeve with unreduced zinc chromate primer (C-201) on faying surfaces, except on bearings which run in oil. If bearing runs in oil, do not use primer. Use type of oil in which the bearing operates.
- △₂ Line ream through both sleeves/bushings.
- △₃ Retain sleeves and bearings with corrosion preventive compound (C-101) on faying surfaces. Use anaerobic primer grade CV (Blue).
- △₄ Stake on both sides of bearing or sleeve, as applicable.
- △₅ Use corrosion preventive compound (C-101) on faying surfaces.
- △₆ Tool may be purchased from: Cabco Industries, El Canton, California, 92021.
- △₇ Tool may be purchased from: Rexnord Inc., Bearing Operation, Downers Grove, Ill. 60515.
- △₈ Apply sealant (C-356) on faying surfaces. Use grade T (Yellow) sealant (C-356).
- △₉ Rotational torque of bearing, after staking, is 1 to 6 inch-pounds. (0.11 to 0.68 Nm).
- △₁₀ Deleted.
- △₁₁ Proof load outer race of bearing, each direction 500 to 800 pounds (2224 to 3559 N).
- △₁₂ Apply anaerobic retaining compound (C-352) to faying surfaces. Do not cure above 200°F (93°C).
- △₁₃ Retain sleeves and bearings with sealant (C-320).
- △₁₄ Retain sleeves and bearings with sealant (C-320) as follows:
- (a) Clean mating surfaces of bearing, sleeve and housing using solvent MEK (C-309).
 - (b) Apply anaerobic primer, grade N (Green), sealant (C-320) with cotton swab and allow to dry 2 to 3 minutes.
 - (c) Position bearing and sleeve in housing. Apply small amounts of sealant, grade CV, color blue, MIL-S-22473 sealant (C-320) to joints between housing and sleeve and between sleeve and bearing. Sealant will flow into joints by capillary action. Repeat application of sealant until a ring of sealant remains just outside joint. Wait a few minutes and remove excess sealant with a clean cloth.
- 

CAUTION
- IF ALUMINUM PARTS OR LUBRICATED BEARINGS ARE INVOLVED, DO NOT EXCEED 200°F (93°C) DURING ACCELERATED CURE.
- (d) Allow seal to cure at room temperature for 60 to 90 minutes. If accelerated cure is required, cure at 200°F (93°C) (maximum) for 15 minutes.
- △₁₅ Maximum breakout or misalignment torque of bearing, after installation, must be 10 inch-pounds (1.13 Nm).

Table 9-5. Bearing and Sleeve Replacement Data (Cont)

NOTES (CONT):



DO NOT USE WATER-BORNE EPOXY PRIMER COATING (C-246) FOR WET INSTALLATIONS.

- △₁₆ On fixed control part, install bearing/bearing sleeve with unreduced epoxy polyamide primer (C-204) on faying surfaces, except on bearings which run in oil. If bearing runs in oil, do not use primer. Use type of oil in which bearing operates.
- △₁₇ Do not paint or prime bearing or bushing bores.
- △₁₈ Magnaflux inspect (Chapter 6).
- △₁₉ Refer to the BHT-206A/B-CR&O manual for detailed instructions.
- △₂₀ Apply MIL-S-22473, Grade N, sealant (C-320) before you apply sealant (C-356) to faying surfaces. Do not cure above 200°F (93°C).
- △₂₁ Apply sealant (C-356) to faying surfaces. Do not cure above 200°F (93°C).
- △₂₂ Breakout or misalignment torque of bearing, after installation, must be 1 to 6 inch-pounds (0.11 to 0.68 Nm).
- △₂₃ No load breakaway torque of bearing, after installation, must be 1 to 55 inch-pounds (0.11 to 6.21 Nm).
- △₂₄ Stake depth to be 0.014 to 0.018 inch (0.355 to 0.457 mm).
- △₂₅ Maximum breakout or misalignment torque of bearing, after installation, must be 1 inch-pound (0.11 Nm).
- △₂₆ Maximum breakout or misalignment torque of bearing, after installation, must be 6 inch-pounds (0.68 Nm).
- △₂₇ Maximum breakout or misalignment torque of bearing, after installation, must be 0.25 to 1.5 inch-pounds (0.03 to 0.17 Nm).
- △₂₈ Install bearings flush to 0.003 inch (0.007 mm) below surface.
- △₂₉ Install P/N 206-001-339-009 spacer with adhesive. Remove all squeeze-out. Apply anaerobic retaining compound (C-352) and install bearings flush to adjacent surfaces within 0.003 inch (0.076 mm).
- △₃₀ Breakout or misalignment torque of bearing, after installation, must be 1 to 7 inch-pounds (0.11 to 0.79 Nm).
- △₃₁ Apply anaerobic retaining compound sealant (C-356) to faying surfaces. Use 1/4-28UNF bolt, nut, and washers to align bearings and spacer during curing cycle. Tighten bolt 25 to 35 inch-pounds (2.82 to 3.95 Nm) torque before curing.
- △₃₂ Breakout or misalignment torque of bearing, after installation, must be 1 to 5 inch-pounds (0.11 to 0.56 Nm).
- △₃₃ Use anaerobic retaining compound sealant (C-356), omit staking.
- △₃₄ Maximum breakaway torque, after staking, is 0.5 inch-pounds (0.06 Nm).

Table 9-5. Bearing and Sleeve Replacement Data (Cont)**NOTES (CONT):**

- ▲₃₅ Apply anaerobic retaining compound sealant (C-356), omit staking. Use 1/4-28UNF bolt to align bearings and spacer during cure cycle, torque bolt 25 to 35 inch-pounds (2.82 to 3.95 Nm) before curing.
- ▲₃₆ Extension of staking sleeve on each side of lug, before staking, to be equal within 0.005 inch (0.127 mm).
- ▲₃₇ After staking and prior to priming and painting, apply grease (C-001) to staked areas of sleeve.
- ▲₃₈ Install flush to 0.010 inch (0.254 mm) below surface (with seals outward). Handpack bearings and cavity with grease (C-001).
- ▲₃₉ Rotational preload for bearing, after installation, to be 1 to 7 inch-pounds (0.11 to 0.79 Nm) at 70 ±10°F (21 ±5.5°C).
- ▲₄₀ Maximum breakaway torque, after staking, is 50 inch-pounds (5.65 Nm).
- ▲₄₁ Refer to the BHT-222-CR&O manual for detailed instructions.
- ▲₄₂ Tool may be purchased from: Ozone Industries, Inc., Ozone Park, New York, 11416.
- ▲₄₃ Remove old retaining compound with 400 grit abrasive cloth or paper (C-423). Apply retaining compound sealant (C-356).
- ▲₄₄ Apply adhesive (C-313) to faying surfaces.
- ▲₄₅ 0.0025 inch (0.01270 mm) over listed dimension permissible.
- ▲₄₆ Press flange against shoulder on one side. Stake opposite side as noted.
- ▲₄₇ Stake depth to be 0.005 to 0.009 inch (0.127 to 0.228 mm).
- ▲₄₈ Refer to the BHT-214B-MM for detailed instructions.
- ▲₄₉ Thermal fit — stress relief not required.
- ▲₅₀ Roll torque of bearing must not exceed 5 inch-pounds (0.56 Nm) at 72°F (22°C).
- ▲₅₁ Roll torque of bearing must not exceed 3 inch-pounds (0.34 Nm) at 72°F (22°C).



DO NOT USE WATER-BORNE EPOXY PRIMER COATING (C-246) FOR WET INSTALLATIONS.

- ▲₅₂ Install with wet epoxy polyamide primer (C-204).
- ▲₅₃ Maximum breakout torque of bearing, after installation, must be 12 inch-pounds (1.36 Nm).
- ▲₅₄ Use 1/4-28UNF bolt, nut, and washers to align bearings and P/N 214-001-064-001 spacer during curing cycle. Torque nut 25 to 35 12 inch-pounds (2.82 to 3.95 Nm) prior to curing.
- ▲₅₅ Ball in bearing can be replaced without replacing race.
- ▲₅₆ Install with sealant (C-320).
- ▲₅₇ Stake depth to be 0.017 to 0.020 inch (0.431 to 0.508 mm).

Table 9-5. Bearing and Sleeve Replacement Data (Cont)

NOTES (CONT):



































-  Assemble P/N 214-060-769 lever in P/N 214-060-768 lever and press sleeve into levers. After bearing is ring staked, check for free movement of P/N 214-060-769 lever in P/N 214-060-768 lever. Install MS20470AD-3 rivet through levers.
-  Each bearing will be subjected to a side load of 200 pounds (889.600 N) and have no evidence of permanent deformation, looseness, or damage.
-  Tool may be purchased from: KAHR Bearing, Burbank, CA 91504. Torque retainer to 148 inch-pounds (16.16 Nm).
-  Stake depth to be 0.005 to 0.009 inch (0.1270 to 0.2286 mm)
-  No load rotational breakaway torque after staking to be 15 inch-pounds (1.70 Nm) maximum.
-  Stake depth to be 0.025 to 0.040 inch (0.6350 to 1.0160 mm).
-  Bearing no load rotational breakaway torque not to exceed 25 inch-pounds (2.82 Nm).
-  Bearing not replaceable.
-  Bearing no load misalignment breakout torque must not exceed 5 inch-pounds (0.56 Nm).
-  Apply Grade N, sealant (C-320) to faying surfaces followed by application of retaining compound (C-352). Do not cure above 200°F (93°C). Do not stake bearing.
-  No load rotational breakaway torque after staking to be 12 inch-pounds (1.36 Nm) maximum.
-  Proof load test bearing installation to 1125 pounds. (5004 N).
-  No load rotational breakaway torque after staking to be 1.0 to 18.0 inch-pounds (0.11 to 2.03 Nm).
-  No load rotational breakaway torque after staking to be 20.0 inch-pounds (2.26 Nm) maximum.
-  Tool may be obtained from: J. R. Potter & Associates, 28602 Knickerbocker Road, Cleveland, Ohio, 44140.
-  Apply MIL-S-22473, Grade N, sealant (C-320) before you apply sealant (C-356) to faying surfaces. Do not stake bearings. Do not cure above 200°F (93°C). Align bearings and spacer during cure cycle so that a 0.8743 inch (22.2072 mm) diameter shaft will pass through both bearings.
-  Apply MIL-S-22473, Grade N, sealant (C-320) before you apply ASTM D5363, Group 04, Class 1, Grade 1, retaining compound (C-352) to faying surfaces.
-  Proof load outer race of bearing to 650 pounds (2891 N), axially.
-  Breakout or misalignment torque of bearing, after installation, must be 0.125 to 5 inch-pounds (0.015 to 0.56 Nm).
-  Proof load inner race of bearing to 360 pounds (1601 N), axially.
-  Breakout or misalignment torque of bearing, after installation, must be 0.125 to 3 inch-pounds (0.015 to 0.34 Nm).
-  Breakout or misalignment torque of bearing, after installation, must be 1.5 inch-pounds (0.17 Nm) maximum.

Table 9-5. Bearing and Sleeve Replacement Data (Cont)**NOTES (CONT):**

-  Apply MIL-S-22473, Grade N, sealant (C-320) before you apply sealant (C-356) to faying surfaces. Do not stake bearings. Do not cure above 200°F (93°C). Use 1/4-28 UNF bolt, nut, and washers to align bearings and spacer during cure cycle. Torque bolt 25 to 35 inch-pounds (2.82 to 3.95 Nm) before curing.
-  Breakout or misalignment torque of bearing, after installation, must be 0.1 to 6 inch-pounds (0.011 to 0.67 Nm).
-  Apply MIL-S-22473, Grade N, sealant (C-320) before you apply ASTM D5363, Group 01, Class 1, Grade 1, sealant (C-320) to faying surfaces. Do not stake bearings. Do not cure above 200°F (93°C). Use bolt, nut, and washers to align bearings during cure cycle.
-  Stake depth to be 0.012 to 0.016 inch (0.3048 to 0.4064 mm).
-  Proof load bearing to 100 pounds (445 N).
-  Breakaway torque, after staking, must be less than 5 inch-pounds (0.56 Nm).
-  Breakaway torque, after staking, must be less than 0.0625 inch-pounds (0.007 Nm).
-  Apply MIL-S-22473, Grade N, sealant (C-320) before you apply sealant (C-356) to faying surfaces. Do not stake bearings. Do not cure above 200°F (93°C). Use 5/16-24 UNF bolt, nut, and washers to align bearings and spacer during cure cycle. Torque bolt 25 to 35 inch-pounds (2.82 to 3.95 Nm) before curing.
-  Breakaway torque, after staking, must be less than 0.0937 inch-pounds (0.0106 Nm).
-  Breakaway torque, after staking, must be less than 1 inch-pounds (0.11 Nm).
-  Breakaway torque, after staking, must be less than 0.3125 inch-pounds (0.0353 Nm).
-  Return the part to Bell Helicopter Textron (BHT) for evaluation and possible installation of replacement bearing. Refer to General Information Letter (IL) [GEN-04-98](#) for the applicable shipping information and to obtain a Return Material Authorization (RMA) number.
-  Refer to [TB 206L-96-189](#).

