

OWNER/OPERATOR INFORMATION MANUAL

COPYRIGHT © 2008
McCAULEY PROPELLER SYSTEMS
WICHITA, KANSAS, USA

MPC26-05

7 APRIL 2008

REVISION 5

1 AUGUST 2020

McCAULEY PROPELLER SYSTEMS
OWNER/OPERATOR
INFORMATION MANUAL

LIST OF EFFECTIVE PAGES

CHAPTER-SECTION-SUBJECT	PAGE	DATE
00-Title		
00-List of Effective Pages	Page 1	Aug 1/2020
00-Record of Revisions		
00-Record of Temporary Revisions		
00-Contents	Page 1	Aug 1/2020
LIST OF REVISIONS	Page 1	Aug 1/2020
INTRODUCTION	Pages 1-8	Aug 1/2020
ICA SUPPLEMENT LIST	Page 1	Mar 13/2013

McCAULEY PROPELLER SYSTEMS
OWNER/OPERATOR
INFORMATION MANUAL

CONTENTS

LIST OF REVISIONS.....	Page 1
General.....	Page 1
Export Compliance.....	Page 1
Proprietary Rights Notice.....	Page 1
INTRODUCTION.....	Page 1
General.....	Page 1
How to Get Customer Assistance.....	Page 1
Coverage.....	Page 2
Instructions for Continued Airworthiness (ICA).....	Page 3
List of Obsolete Documents.....	Page 4
List of Incorporated Documents.....	Page 5
Applicable Service Bulletins and Service Letters.....	Page 5
Cross Reference Listing of Popular Name Verses Model Numbers.....	Page 5
Using the Owner/Operator Information Manual.....	Page 6
Dimensions and Units.....	Page 7
Temporary Revisions.....	Page 7
Material Presentation.....	Page 7
Service Bulletins.....	Page 7
List of Effective Pages.....	Page 7
Revision Filing Instructions.....	Page 7
Identifying Revised Material.....	Page 7
Warnings, Cautions and Notes.....	Page 8
Log Book.....	Page 8
Customer Comments on Manual.....	Page 8
ICA SUPPLEMENT LIST.....	Page 1

McCAULEY PROPELLER SYSTEMS
OWNER/OPERATOR
INFORMATION MANUAL

LIST OF REVISIONS

1. General

- A. This manual, MPC-26, includes the original issue and the revisions listed in Table 1. To ensure information in this manual is current and the latest maintenance and inspections procedures are available, the revisions must be incorporated in the manual as they are issued.

Table 1. Original Issue -- April 7, 2008

Revision Number	Date	Revision Number	Date
1	Dec 7, 2009	2	Mar 13, 2013
3	Aug 18, 2014	4	Oct 19, 2015
5	Aug 1, 2020		

- B. FAA Approved Airworthiness Limitations are incorporated in this maintenance manual as Chapter 4. Revisions to Chapter 4 are dated as approved by the FAA Regional Manager, Aircraft Certification Office. To ensure that the maintenance information required under Parts 43.16 and 91.403 of Part 14 of the Code of Federal Regulations is current, the revisions listed in Table 2 must be incorporated in Chapter 4 as they are issued.

Table 2. Original Issue-- March 13, 2013

Revision Number	Date	Revision Number	Date
------------------------	-------------	------------------------	-------------

2. Export Compliance

- A. This publication contains technical data and is subject to U.S. export regulations. This information has been exported from the United States in accordance with export administration regulations. Diversion contrary to U.S. law is prohibited.

ECCN: 9E991

3. Proprietary Rights Notice

- A. These data are proprietary to Textron Aviation Inc. Use of this publication or any of the data contained herein for any purpose other than direct aircraft operation or maintenance is prohibited without prior written authorization from Textron Aviation Inc. Reproduction or redistribution of this publication in whole or in part is prohibited.

McCAULEY PROPELLER SYSTEMS
OWNER/OPERATOR
INFORMATION MANUAL

INTRODUCTION

1. General

- A. The instructions for continued airworthiness (ICA) in this publication uses the data available at the time of publication. This publication is updated, supplemented, and changed by service letters, service bulletins, publication revisions, reissues, ICA supplements, and temporary revisions, which are supplied by subscription services available from McCauley Product Support. All of these changes become part of and are specifically included in this publication which is the principal manual for ICA. The latest changes to this publication are given through the McCauley Product Support subscription services and/or McCauley authorized service facilities.

The purchaser is warned not to use the data in McCauley's overhaul/maintenance/service/information manuals when parts are designed, manufactured, remanufactured, overhauled, and/or approved by entities, other than McCauley or McCauley authorized entities, are installed. When non-McCauley parts are used, the data in McCauley's overhaul/maintenance/service/information manuals is no longer applicable. All of the inspection intervals, replacement time limits, overhaul time limits, inspection methods, life limits, cycle limits, etc., McCauley recommends are given when new, remanufactured, or overhauled McCauley approved parts are installed. All inspection intervals, replacement time limits, overhaul time limits, the methods of inspection, life limits, cycle limits, etc., for non-McCauley parts must come from the manufacturer and/or seller of the non-McCauley parts.

- B. Inspection, maintenance and parts requirements for Supplemental Type Certificate (STC) installations are not given in this manual. When the propeller has an STC installation, those parts of the propeller that the installation has an effect on, must be examined in accordance with the inspection program published by the owner of the STC. McCauley-supplied inspection criteria may not be valid for propellers that have STC installations because they may change the systems interface, operating characteristics and component loads or stresses on adjacent structures.

Any inspection and/or repair requiring disassembly, reassembly or overhaul of a McCauley propeller must be done in an FAA-approved or international equivalent propeller repair station by qualified personnel.

- C. Users of this manual are presumed to have sufficient training to follow these instructions carefully and correctly.
- D. The inspection requirements are stated in a manner to establish what propeller component is to be inspected, preferred inspection method, and criteria for airworthiness.

2. How to Get Customer Assistance

- A. REVISIONS, REISSUES and TEMPORARY REVISIONS can be purchased directly from McCauley:, Attention: Technical Publications, e-mail: customercare@mccauley.textron.com, Telephone 316-517-5800, Telefax 316-517-7271.

- B. Product Support.

McCauley Product Support	
Mailing Address	McCauley Propeller Systems P.O. Box 7704 Wichita, KS 67277-7704

- (1) If you need assistance with a general support question, publication information, subscriptions, or maintenance programs visit our website at www.mccauley.textron.com or contact:

McCAULEY PROPELLER SYSTEMS
OWNER/OPERATOR
 INFORMATION MANUAL

McCauley Product Support	
Phone Numbers	Wichita, Kansas 1-800-621-7767 or 316-831-4021
Fax	316-206-9948
Email Address	productsupport@mccauley.textron.com

3. Coverage

- A. The McCauley MPC26 Owner/Operator Information Manual is prepared with information given by the ATA (Air Transport Association) Specification Number 2200 for Manufacturer's Technical Data.
- B. The information in this Owner/Operator Information Manual is applicable to the following model propellers:

Table 1. Propeller Models

Fixed Pitch Propeller Models					
1A90/CF	1A90/CH	1B90/CM	1B90/ECM	1B90/FCM	1B90/LCM
1C90/ALM	1C90/CLM	1C90/DLM	1C90/LF	1C90/LM	1A100/ACM
1A100/MCM	1A101/DCM	1A105/SCM	1A101/HCM	1A101GCM	1A101/PCM
1A102/OCM	1A103/TCM	1A105/BCM	1A105/SLM	1A135/BRM	1A135/CRM
1A135/DRM	1A135/JCM	1A135/KCM	1A135/RM	1C160/CTM	1C160/DTM
1C160/EGM	1C160/FGM	1A162/TCD	1A170/BMS	1A170/CFA	1A170/DF
1A170/DM	1A170/EFA	1A170/FFA	1A170/GM	1A170E/JFA	1A170E/JHA
1A170/KFA	1A170/L	1A170/LL	1A170/SFA	1A170/SFC	1C172/AGM
1C172/BTM	1C172/EM	1C172/MDM	1C172/MFA	1C172/MGM	1C172/MTM
1C172/SBTM	1C172/TM	1A175/ATM	1A175/DM	1A175/ETM	1A175/FC
1A175/GM	1A175/GMA	1A175/SFC	1B175/MFC	1A200/AOM	1A200/DFA
1A200/FA	1A200/FM	1A200/HFA	1A200/WFA	1B200/HM	1C200/FC
1D200/OM	1A230/AFC	1B235/BFA	1B235/DFC	1B235/EFC	1C235/LFA
1P235/AFA	1P235/PFA				

Table 2. Propeller Models

Constant Speed Propeller Models					
2A34C201	2D34C202	2A34C203	C2A34C204	B2A34C205	B2D34C206
B2D34C207	B2D34C208	2A34C209	2A34C210	B2D34C211	B2D34C212
B2D34C213	B2D34C214	2D34C215	2A34C216	B2D34C217	B2D34C218
B2D34C219	B2D34C220	2A34C221	2A37C223	B2D37C224	B2A34C225
2A34C227	B2A37C228	B2D37C229	D2A37C230	D2A37C231	2A37C232
E2A37C233	E2A37C234	B2D34C235	C2D37C236	B2A37C238	2A34C239
2A34C240	2A34C241				

McCAULEY PROPELLER SYSTEMS
OWNER/OPERATOR
 INFORMATION MANUAL

Table 2. Propeller Models (continued)

Constant Speed Propeller Models					
D2AF34C301	D2AF34C302	D2AF34C303	D2AF34C304	D2AF34C305	2AF34C306
D2AF34C307	D2AF34C308	D2AF34C310			
D3A34C401	D3A34C402	D3A34C403	D3A34C404	B3D34C405	3A32C406
B3D32C407	D3A32C408	D3A32C409	D3A36C410	D3A32C411	B3D32C412
B3D34C413	B3D32C414	C3D36C415	B3D36C416	B3D32C417	3A32C418
B3D32C419	D3A34C420	B3D34C421	3A34C422	3A34C423	B3D36C424
B3D36C427	B3D36C428	B3D36C429	B3D36C430	B3D36C431	B3D36C432
B3D36C433	3A36C434	D3A36C435	D3A36C436	B3D36C442	D3A34C443
D3A34C444	D3A34C447				
3FF32C501	3AF34C502	3AF34C503	3AF32C504	3AF32C505	3AF32C506
3AF32C507	3AF32C508	3AF32C509	3AF37C510	3AF32C511	3AF32C512
3AF36C514	3AF32C515	3AF37C516	3AF32C521	3AF32C522	3AF32C523
3AF32C524	3AF32C525	B3DF36C526	B3DF36C527	3AF32C528	3FF34C529
3GFR34C601	3GFR34C602	4HFR34C652	4HFR34C653	4HFR34C661	4HFR34C662
4HFR34C663	4HFR34C664	4HFR34C665			
3GFR34C701	3GFR34C702	3GFR34C703	3GFR34C704	4HFR34C754	4JFR34C758
4HFR34C762	4HFR34C763	4HFR34C764	4HFR34C766	4HFR34C768	4HFR34C769
4HFR34C771	4HFR34C773	4HFR34C774	4HFR34C775	4HFR34C778	4HFR34C779
5JFR36C1003	5HFR34C1008				
B5JFR36C110 1	C5JFR36C1102	B5JFR36C1103	C5JFR36C1104	5HFR34C1105	

NOTE: All model 4HFR34C755 propellers are required to be converted to a model 4HFR34C754 propeller. Refer to the latest revision of McCauley Service Bulletin 175 for instructions and a listing of the parts required to convert a 4HFR34C755 propeller to a 4HFR34C754 model propeller.

- C. This manual gives the necessary information required to help maintenance personnel service, examine, troubleshoot, remove and install McCauley Propellers.
- D. Information in this manual is applicable to all U.S. and Foreign Certified propellers.

4. Instructions for Continued Airworthiness (ICA)

A. Owner/Operator Information Manual.

- (1) The instructions provided in this manual are the principal instructions for continued airworthiness. This manual may be revised to add changes to the ICAs or to add additional ICAs when changes to an affected propeller type design require changes to these instructions. When a revision to this manual is not possible within the time constraints for these ICAs, the instructions may be transmitted with a temporary revision or with an ICA supplement. Temporary revisions will be incorporated in the next revision to this manual and ICA supplements will also be incorporated in the next revision unless these instructions require restricted distribution.

McCAULEY PROPELLER SYSTEMS
OWNER/OPERATOR
 INFORMATION MANUAL

B. Temporary Revisions.

- (1) Temporary revisions may be produced to transmit supplemental instructions for continued airworthiness when a revision to the owner/operator information manual is not possible within the time constraints for these ICAs. They consist of complete page blocks which replace the existing paper and will temporarily supersede the CD-ROM data. Temporary revisions will be included on the CD-ROM on the next CD-ROM release. Temporary revisions are numbered consecutively in the ATA chapter assignment. Page numbering uses the three-element number, which matches the owner/operator information manual.
- (2) Paper Version of the owner/operator information.
 - (a) Paper temporary revisions will be distributed on yellow paper. File the temporary revision cover sheet after the title page of the chapter to which it applies and substitute or add the remaining pages in the paper manual.
- (3) Electronic (CD-ROM) Version of the Maintenance Manual.
 - (a) The cover sheet will be located in the maintenance manual CD-ROM library at the beginning of the chapter to which it applies and the changed or added pageblocks will be located in the appropriate location by ATA. All revised or added information will be highlighted blue.

C. ICA Supplements.

- (1) ICA supplements may be produced to transmit supplemental instructions for continued airworthiness when a revision to the owner/operator information manual is not possible within the time constraints for these ICAs. ICA supplements will provide supplemental instructions for one or more ICA manual and is to be used in conjunction with the affected manuals (maintenance manual, wiring diagram manual, etc.) until those instructions are incorporated into the manuals. ICA supplements are numbered consecutively by model in the ATA chapter assignment. Page numbering uses the three-element number, which matches the affected manuals.
- (2) Refer to the ICA Supplement List to determine the incorporation status for each manual affected.

5. List of Obsolete Documents

- A. The following service information has been incorporated into this manual. This service information is now obsolete and replaced by this manual for the propellers affected by this manual.

Service Bulletin Number	Service Bulletin Date	Manual Incorporation
SB137AE	2/17/10	Revision 2
SB176E	3/3/03	Revision 2
SB177B	6/30/92	Revision 2
SB227B	8/28/01	Revision 2

Service Letter Number	Service Letter Date	Manual Incorporation
SL1991-10A	10/29/96	Revision 2
1992-14C	6/28/96	Revision 2
1992-17	11/16/92	Revision 2
1994-24A	2/10/95	Revision 2
1995-5A	12/5/07	Revision 2
1996-7	10/29/96	Revision 2
1997-4	4/22/97	Revision 2
SL1998-23	9/21/98	Revision 2

McCAULEY PROPELLER SYSTEMS
OWNER/OPERATOR
 INFORMATION MANUAL

Service Letter Number	Service Letter Date	Manual Incorporation
1999-8B	3/15/01	Revision 2
2000-7	8/1/00	Revision 2
2000-8A	11/20/00	Revision 2
2003-8	12/23/03	Revision 2
SL2006-5A	5/2/11	Revision 3
SL2010-5	11/22/10	Revision 2
SL2010-6	11/22/10	Revision 2

6. List of Incorporated Documents

- A. The following service information has been incorporated into this manual. Due to the relationship of the service information to active Airworthiness Directives, the service information also remains active.

Service Bulletin Number	Service Bulletin Date	Manual Incorporation	Airworthiness Directive Number
--------------------------------	------------------------------	-----------------------------	---------------------------------------

7. Applicable Service Bulletins and Service Letters

- A. Alert Service Bulletin.
 - (1) Alert Service Bulletins are technical documents that provide instructions and, if applicable, part information for the incorporation of an installation, modification, or repair to a specific propeller or propeller component. Alert Service Bulletins are used to announce mandatory special product inspection criteria and modifications, revised maintenance information and/or revised operational information which has been determined to be critical for the continued safe and reliable performance of the propeller, or propeller component.
- B. Service Bulletin.
 - (1) Service Bulletins are technical documents that provide instructions and, if applicable, part information for the incorporation of an installation, modification, or repair to a specific propeller or propeller component. Service Bulletins are used to announce special product inspection criteria and modifications, revised maintenance information and/or revised operational information which has been determined to be critical for the continued safe and reliable performance of the propeller, or propeller component.
- C. Service Letter.
 - (1) Service Letters are used to announce support and service information.
- D. Special Service Project.
 - (1) Special Service Projects (SSP's) are similar to service bulletins and are used to announce special product inspection criteria and modifications, revised maintenance information and/or revised operational information which is intended to assist in improving propeller safety, reliability, durability and/or performance. SSP's typically contain similar information and/or headings as service bulletins, but are often tailored for special situations and/or conditions or logistical requirements that may affect only a limited number of propellers. One additional heading that can be found on a SSP is the heading titled "Duration". The Duration heading provides an expiration date for the SSP when used.

8. Cross Reference Listing of Popular Name Verses Model Numbers

- A. All propellers are certified under model number designations. However, in this manual reference to specific propellers is almost always by the shortened propeller model number unless the full model number is necessary to differentiate between versions of the same basic model.

McCAULEY PROPELLER SYSTEMS
OWNER/OPERATOR
INFORMATION MANUAL

Example: the D3A34C444/78ML[X] propeller assembly is shortened to the Hub model designation D3A34C444 which can also be shortened to C444.

9. Using the Owner/Operator Information Manual

A. Division of Subject Matter.

- (1) This manual is divided into two chapters which are divided by section and subject. The manual divisions are as follows:

Chapter-Section-Subject	Title
	Introduction
4-00-00	Airworthiness Limitations
4-10-00	Inspection Time Limits
4-11-00	Replacement Time Limits
61-00-01	Fixed Pitch Propeller
61-00-04	Constant Speed Propeller
61-00-06	Propeller

B. Page Numbering System.

- (1) All system/subsystem/unit (chapter/section/subject) maintenance data is separated into specific types of information: description and operation, troubleshooting, maintenance practices. Blocks of sequential page numbers are used to identify the type of information:

Page 1 through 99	Description and Operation
Page 101 through 199	Troubleshooting
Page 201 through 299	Maintenance Practices

- (2) Relatively simple units may not require description and operation, troubleshooting information. In such cases, these pages are omitted. When subtopics are brief, they may be combined into a topic entitled Maintenance Practices. Maintenance Practices is actually a combination of subtopics, including Servicing, Removal/Installation, Adjustment/Test, Cleaning/Painting or Approved Repairs.
- (3) Lengthy subtopics may be treated as an individual topic. Page numbering for the individual topics is as follows:

Page 301 through 399	Servicing
Page 401 through 499	Removal/Installation
Page 501 through 599	Adjustment/Test
Page 601 through 699	Inspection/Check
Page 701 through 799	Cleaning/Painting
Page 801 through 899	Approved Repairs

- (4) Illustrations are tied into the page numbering system. For example, all illustrations within a 200 page numbering section will begin with the number 2 (i.e. Figure 201, Figure 202, etc.). All illustrations within a 300 page numbering section will begin with the number 3 (Figure 301, Figure 302, etc.).

McCAULEY PROPELLER SYSTEMS
OWNER/OPERATOR
INFORMATION MANUAL

10. Dimensions and Units

- A. Dimensions and Units.
- (1) All dimensions and units are given in both English and metric (International System of Units [SI]) units in the text and the illustrations. The English value is given and then the metric unit is given in parenthesis.
 - (2) Metric units are given in standard abbreviations.
 - (3) Station lines and locations are not given in metric units.

11. Temporary Revisions

- A. Additional information which becomes available may be provided by temporary revision. This service is used to provide, without delay, new information which will assist in maintaining safety. Temporary revisions are numbered consecutively within the ATA chapter assignment. Temporary revisions are normally incorporated into the manual at the next regularly scheduled revision.

12. Material Presentation

- A. This manual is available on paper and CD.

13. Service Bulletins

- A. Service bulletins may require special inspections and authorize modifications to propellers. As service bulletins are issued, they will be incorporated in the next scheduled revision and noted in the Service Bulletin List, included in this Introduction. The list of service bulletins uses three columns to summarize information:
- (1) Service Bulletin Number - This column identifies the bulletin by number.
 - (2) Service Bulletin Date - This column indicates the initial date the bulletin became active.
 - (3) Manual Incorporation - This column indicates the date the service bulletin has been incorporated in the manual.

14. List of Effective Pages

- A. A list of effective pages is provided at the beginning of each chapter. All pages in the specific chapter are listed in numerical sequence on the Effectivity Page(s) with the date of issue for each page.

15. Revision Filing Instructions

- A. Regular Revision.
- (1) Pages to be removed or inserted in the manual are determined by the effectivity page. Pages are listed by the three-element number (chapter/section/subject) and then by page number. When two pages display the same three-element number and page number, the page with the most recent Date of Page Issue shall be inserted in the manual. The date column on the corresponding chapter effectivity page shall verify the active page.
- B. Temporary Revision.
- (1) File temporary revisions in the applicable chapter(s) in accordance with filing instructions appearing on the first page of the temporary revision.
 - (2) The rescission of a temporary revision is accomplished by incorporation into the manual or by a superseding temporary revision. A Record of Temporary Revisions is furnished in the Temporary Revision List located previous to the Introduction. A Manual Incorporation Date column on the Temporary Revision List page will indicate the date the Temporary Revision was incorporated, thus authorizing the rescission of the temporary revision.

16. Identifying Revised Material

- A. Additions or revisions to text in an existing section will be identified by a revision bar in the left margin of the page and adjacent to the change.

NOTE: Due to the extensive changes and reformatting in revision 2 of this manual, all change bars have been omitted for this revision.

McCAULEY PROPELLER SYSTEMS
OWNER/OPERATOR
INFORMATION MANUAL

- B. Revised text inside tables, including Appendices, will not display revision bars; however, the affected page will display the current revision date in the Date of Page Issue location.
- C. When extensive technical changes are made to text in an existing section that requires extensive revision, revision bars will appear the full length of text.
- D. When art in an existing illustration is revised, a revision bar along the entire vertical length of one side of the illustration will be used to indicate changes to the illustration.

17. Warnings, Cautions and Notes

- A. Throughout the text in this manual, warnings, cautions and notes pertaining to the procedures being accomplished are included. These adjuncts to the text are used to highlight or emphasize important points. Warnings and Cautions precede the text to which they apply, and Notes follow the text to which they apply.
 - (1) **WARNING** - Calls attention to use of materials, processes, methods, procedures or limits which must be followed precisely to avoid injury or death to persons.
 - (2) **CAUTION** - Calls attention to methods and procedures which must be followed to avoid damage to equipment.
 - (3) **NOTE** - Calls attention to methods which will make the job easier.

18. Log Book

- A. The owner/operator is required to maintain a permanent log book for each serial numbered propeller assembly containing the following information:
 - (1) The total time (flight hours) in service of each propeller assembly including flight hours on each serial numbered hub and blade.
 - (2) The airplane on which the propeller has been installed. (Recorded by the airplane manufacturer, registration number (tail number), aircraft serial number, and model types.)
 - (3) The time in service (flight hours) and the calendar period (months, days, years) each propeller assembly (recorded by hub and blade serial numbers) was installed on an aircraft.
 - (4) Records of the maintenance, inspections, alterations and overhauls performed on each propeller assembly.
 - (a) The records must include:
 - 1 A description of the work performed, including the disposition of the affected parts.
 - 2 The date that the work was accomplished.
 - 3 The signature and certification number of the person approving the propeller assembly for return to service.

19. Customer Comments on Manual

- A. McCauley Propeller Systems has endeavored to furnish you with an accurate, useful, and up-to-date manual. This manual can be improved with your help. Please return the registration card to receive revisions to this manual. Please contact McCauley Product Support to report any errors, discrepancies, and omissions in this manual as well as any general comments you wish to make.

McCAULEY PROPELLER SYSTEMS
OWNER/OPERATOR
INFORMATION MANUAL

ICA SUPPLEMENT LIST

ICA Supplement Number	Title	ICA Supplement Date	Manual Incorporation Date
----------------------------------	--------------	------------------------------------	--

NOTE: No ICA Supplements have been issued that affect this manual.

CHAPTER

4

AIRWORTHINESS LIMITATIONS

THE AIRWORTHINESS LIMITATIONS SECTION IS FAA APPROVED AND GIVES INSPECTIONS AND MAINTENANCE THAT ARE REQUIRED BY PARTS 43.16 AND 91.403 OF TITLE 14 OF THE CODE OF FEDERAL REGULATIONS, UNLESS AN ALTERNATIVE PROGRAM HAS BEEN FAA APPROVED.

APPROVED BY *Margaret Kline*

Margaret Kline, Manager
Aircraft Certification Office
Federal Aviation Administration
Wichita, Kansas

DATE OF APPROVAL *13 March 2013*

13 MARCH 2013

McCAULEY PROPELLER SYSTEMS
OWNER/OPERATOR
INFORMATION MANUAL

LIST OF EFFECTIVE PAGES

CHAPTER-SECTION-SUBJECT	PAGE	DATE
04-Title		
04-List of Effective Pages		
04-Record of Temporary Revisions		
04-Table of Contents		
4-00-00	Page 1	Mar 13/2013
4-10-00	Pages 1-3	Mar 13/2013
4-11-00	Pages 1-2	Mar 13/2013

APPROVED BY *Margaret Kline*

Margaret Kline, Manager
Aircraft Certification Office
Federal Aviation Administration
Wichita, Kansas

DATE OF APPROVAL *13 March 2013*

McCAULEY PROPELLER SYSTEMS
OWNER/OPERATOR
INFORMATION MANUAL

CONTENTS

AIRWORTHINESS LIMITATIONS	4-00-00 Page 1
Scope.....	4-00-00 Page 1
Definition.....	4-00-00 Page 1
INSPECTION TIME LIMITS.....	4-10-00 Page 1
General	4-10-00 Page 1
Inspection Schedule.....	4-10-00 Page 1
REPLACEMENT TIME LIMITS	4-11-00 Page 1
General	4-11-00 Page 1
Blade Life Limits	4-11-00 Page 1
Hub Life Limits.....	4-11-00 Page 2

McCAULEY PROPELLER SYSTEMS
OWNER/OPERATOR
INFORMATION MANUAL

AIRWORTHINESS LIMITATIONS - GENERAL

1. Scope

- A. This chapter outlines the mandatory replacement times and inspection intervals for propeller components considered to be life limited, or to require monitoring through scheduled inspections. This chapter applies to items such as fatigue components and structures that are considered a part of the certification process.

NOTE: The Airworthiness Limitations section is FAA Approved and specifies maintenance required by 14 CFR 43.16 and 91.403, unless an alternative program has been FAA approved.

2. Definition

- A. This chapter contains two sections as outlined below.
- (1) Inspection Time Limits (4-10-00) describes and lists components that are required to be inspected at specified intervals. The intervals specified represent the maximum time allowable between inspections.
 - (2) Replacement Time Limits (4-11-00) describes and lists life limited components that are to be replaced at a specific time.

McCAULEY PROPELLER SYSTEMS
OWNER/OPERATOR
 INFORMATION MANUAL

INSPECTION TIME LIMITS

1. General

- A. The inspection time intervals for the following components represent the maximum inspection intervals which must be adhered to.
- B. The inspections required by this publication require disassembly and checks required in the overhaul manual.

2. Inspection Schedule

- A. Fixed Pitch Propellers
 - (1) Refer to Table 1., Fixed Pitch Propeller Inspection Time Limits for a list of propellers that have an inspection time limit.

Table 1. Fixed Pitch Propeller Inspection Time Limits.

<i>Propeller Model Designation</i>	<i>Description</i>	<i>Inspection Time Limit</i>
1A103/TCM	Propeller Fluorescent Dye Penetrant Inspect (Applies to 1A103/TCM propellers only. Refer to McCauley Alert Service Bulletin ASB221E, and Federal Aviation Administration Airworthiness Directive AD 2010-04-05 for propeller inspection procedures.)	Initial inspection shall occur prior to 1500 hours of operation. Repeat the inspection every 750 hours of operation. NOTE: If time-since-new (TSN) is unknown, inspect the propeller within 50 operating hours of the effective date of AD 2010-04-05.
1A170/FFA	Propeller Fluorescent Dye Penetrant Inspect (Applies to 1A170/FFA propellers only. Refer to Federal Aviation Administration Airworthiness Directive AD 82-27-01 for propeller inspection procedures.)	Inspect every 200 hours of operation.

- B. Constant Speed Propellers
 - (1) Propeller Blades
 - (a) Refer to Table 2., Propeller Blade Inspection Time Limits for a list of propeller blades that have an inspection time limit.

McCAULEY PROPELLER SYSTEMS
OWNER/OPERATOR
 INFORMATION MANUAL

Table 2. Propeller Blade Inspection Time Limits.

Propeller Model Designation	Inspection Time Limited Component Part Number	Description	Inspection Time Limit
C653	L106FA-0	Propeller Blade Fluorescent Dye Penetrant or Eddy Current Inspect (Applies to 4HFR34C653/L106FA-0 propeller assemblies only. Refer to McCauley Alert Service Bulletin ASB234 and Federal Aviation Administration Airworthiness Directive AD 2000-15-10 for propeller blade inspection procedures.)	Inspect every 600 hours of operation.
C1101	114GCA-0	Propeller Blade Fluorescent Dye Penetrant and Eddy Current Inspect (Applies to B5JFR36C1101/114GCA-0 propeller assemblies only. Refer to McCauley Alert Service Bulletin ASB255A and Federal Aviation Administration Airworthiness Directive AD 2009-19-04 for propeller blade inspection procedures.)	Inspect at 2,500 hours Total Time In Service (TTIS)
C1102	L114GCA-0	Propeller Blade Fluorescent Dye Penetrant and Eddy Current Inspect (Applies to C5JFR36C1102/L114GCA-0 propeller assemblies only. Refer to McCauley Alert Service Bulletin ASB255A and Federal Aviation Administration Airworthiness Directive AD 2009-19-04 for propeller blade inspection procedures.)	Inspect at 2,500 hours Total Time In Service (TTIS)
C1103	114HCA-0	Propeller Blade Fluorescent Dye Penetrant and Eddy Current Inspect (Applies to B5JFR36C1103/114HCA-0 propeller assemblies only. Refer to McCauley Alert Service Bulletin ASB255A and Federal Aviation Administration Airworthiness Directive AD 2009-19-04 for propeller blade inspection procedures.)	Inspect at 2,500 hours Total Time In Service (TTIS)
C1104	L114HCA-0	Propeller Blade Fluorescent Dye Penetrant and Eddy Current Inspect (Applies to C5JFR36C1104/L114HCA-0 propeller assemblies only. Refer to McCauley Alert Service Bulletin ASB255A and Federal Aviation Administration Airworthiness Directive AD 2009-19-04 for propeller blade inspection procedures.)	Inspect at 2,500 hours Total Time In Service (TTIS)

McCAULEY PROPELLER SYSTEMS
OWNER/OPERATOR
INFORMATION MANUAL

- (2) Propeller Hubs
 - (a) There are no inspection time limits for the propeller hubs.

McCAULEY PROPELLER SYSTEMS
OWNER/OPERATOR
 INFORMATION MANUAL

REPLACEMENT TIME LIMITS

1. General

A. Components that have reached the replacement times listed must be permanently withdrawn from service.

2. Blade Life Limits

A. Refer to Table 1, Propeller Blade Life Limits for a list of propeller blades that are life limited.

Table 1. Propeller Blade Life Limits

<i>Propeller Model Designation</i>	<i>Life Limited Component Part Number</i>	<i>Description</i>	<i>Life Limit</i>
C406	82NDB-X	Propeller Blade	Replace 10,000 hours
C409	82NDB-X	Propeller Blade	Replace 10,000 hours
C653	L106FA-0 Blades with <u>no</u> change letter	Propeller Blade (Applies only to 4HFR34C653 propeller assembly blades that are installed on or blades that ever have been installed on Jetstream Series 3200 aircraft or the service history is unknown.)	Remove from service, life limit has expired.
C653	L106FA-0 Blades <u>with</u> change letter "A"	Propeller Blade (Applies only to 4HFR34C653 propeller assembly blades that are installed on or blades that ever have been installed on Jetstream Series 3200 aircraft or the service history is unknown.)	Replace 16,000 hours
C663	L106KA-0	Propeller Blade (Applies to 4HFR34C663 propeller assemblies only.)	Replace 16,000 hours
C665	L106FRA-0	Propeller Blade (Applies to 4HFR34C665 propeller assemblies only.)	Replace 10,000 hours
C1101	114GCA-0	Propeller Blade (Applies to B5JFR36C1101/114GCA-0 propeller assemblies only. Refer to McCauley Alert Service Bulletin ASB255A, and Federal Aviation Administration Airworthiness Directive AD 2009-19-04.)	Replace 3500 hours

McCAULEY PROPELLER SYSTEMS
OWNER/OPERATOR
 INFORMATION MANUAL

Table 1. Propeller Blade Life Limits (continued)

Propeller Model Designation	Life Limited Component Part Number	Description	Life Limit
C1102	L114GCA-0	Propeller Blade (Applies to C5JFR36C1102/L114GCA-0 propeller assemblies only. Refer to McCauley Alert Service Bulletin ASB255A and Federal Aviation Administration Airworthiness Directive AD 2009-19-04.)	Replace 3500 hours
C1103	114HCA-0	Propeller Blade (Applies to B5JFR36C1103/114HCA-0 propeller assemblies only. Refer to McCauley Alert Service Bulletin ASB255A and Federal Aviation Administration Airworthiness Directive AD 2009-19-04.)	Replace 3500 hours
C1104	L114HCA-0	Propeller Blade (Applies to C5JFR36C1104/L114HCA-0 propeller assemblies only. Refer to McCauley Alert Service Bulletin ASB255A and Federal Aviation Administration Airworthiness Directive AD 2009-19-04.)	Replace 3500 hours

3. Hub Life Limits

- A. Refer to Table 2, Propeller Hub Life Limits for a list of propeller hubs that are life limited.

Table 2. Propeller Hub Life Limits

Propeller Model Designation	Life Limited Component Part Number	Description	Life Limit
C406	D-5868	Hub Assembly	Replace 10,000 hours
C406	D-7479	Hub Assembly	Replace 10,000 hours
C409	D-5872	Hub Assembly	Replace 10,000 hours
C409	D-7740	Hub Assembly	Replace 10,000 hours
C665	D-6153	Hub Assembly	Replace 10,000 hours
C1101	D6713-1	Hub Assembly (Applies to B5JFR36C1101/114GCA-0 propeller assemblies only)	Replace 6000 hours
C1102	D6713-2	Hub Assembly (Applies to C5JFR36C1102/L114GCA-0 propeller assemblies only)	Replace 6000 hours
C1103	D6713-3	Hub Assembly (Applies to B5JFR36C1103/114HCA-0 propeller assemblies only)	Replace 6000 hours
C1104	D6713-4	Hub Assembly (Applies to C5JFR36C1104/L114HCA-0 propeller assemblies only)	Replace 6000 hours

CHAPTER

61

PROPELLERS

McCAULEY PROPELLER SYSTEMS
OWNER/OPERATOR
INFORMATION MANUAL

61 - LIST OF EFFECTIVE PAGES

CHAPTER-SECTION-SUBJECT	PAGE	DATE
61-Title		
61-List of Effective Pages	Page 1	Aug 1/2020
61-Record of Temporary Revisions		
61-Contents	Pages 1-3	Aug 1/2020
61-00-01	Pages 1-5	Mar 13/2013
61-00-04	Pages 1-19	Mar 13/2013
61-00-06	Pages 101-109	Mar 13/2013
61-00-06	Pages 201-206	Aug 1/2020
61-00-06	Pages 401-425	Aug 1/2020
61-00-06	Page 501	Mar 13/2013
61-00-06	Pages 601-617	Aug 1/2020
61-00-06	Pages 701-710	Aug 1/2020
61-00-06	Pages 801-808	Mar 13/2013
61-00-06	Pages 1001-1005	Mar 13/2013
61-10-40	Pages 1-13	Aug 18/2014
61-10-40	Pages 101-106	Aug 1/2020
61-10-40	Pages 401-427	Aug 1/2020
61-10-40	Page 501	Aug 18/2014
61-10-40	Pages 601-606	Aug 1/2020
61-10-40	Pages 801-804	Aug 18/2014
61-10-40	Pages 1001-1041	Aug 1/2020
61-10-45	Pages 201-214	Aug 1/2020
61-10-45	Page 601	Oct 19/2015
61-10-45	Pages 1001-1004	Oct 19/2015

McCAULEY PROPELLER SYSTEMS
OWNER/OPERATOR
INFORMATION MANUAL

61 - CONTENTS

FIXED PITCH PROPELLER DESCRIPTION	61-00-01 Page 1
Metal Fixed Pitch Propellers	61-00-01 Page 1
Blade Serial Number Stamping Information.....	61-00-01 Page 2
CONSTANT SPEED PROPELLER SYSTEM DESCRIPTION AND OPERATING PRINCIPLES	61-00-04 Page 1
Reciprocating (Piston) Engine Propellers	61-00-04 Page 1
Turbine Engine Propellers	61-00-04 Page 7
Overhaul Period	61-00-04 Page 15
Propeller Model Designation	61-00-04 Page 15
PROPELLER TROUBLESHOOTING	61-00-06 Page 101
General Information	61-00-06 Page 101
Operation in Restricted Power or RPM Conditions (Turbine)	61-00-06 Page 101
Propeller RPM Fluctuations (Constant Speed Piston, Turbine)	61-00-06 Page 101
Changing RPM or Creeping (Constant Speed Piston, Turbine)	61-00-06 Page 102
Improper Propeller Static RPM (Piston)	61-00-06 Page 102
Improper Propeller Maximum RPM in Flight (Constant Speed Piston)	61-00-06 Page 103
Propeller Fails to Control	61-00-06 Page 103
Propeller Feathers at Shutdown (300, 500, 600, 650, and 1100 Model Series Only)	61-00-06 Page 105
Propeller Fails to Feather Properly.....	61-00-06 Page 105
Vibration Troubleshooting	61-00-06 Page 105
Unusual Aircraft Vibration	61-00-06 Page 106
Blade Shake.....	61-00-06 Page 107
Oil or Grease Leaks	61-00-06 Page 107
Propeller Overspeeding.....	61-00-06 Page 109
PROPELLER MAINTENANCE PRACTICES.....	61-00-06 Page 201
Ground Support Equipment	61-00-06 Page 201
Procedures For Maintenance.....	61-00-06 Page 201
Long Term Storage of Controllable Pitch Propellers	61-00-06 Page 202
Long Term Storage of Governors and Accumulators	61-00-06 Page 203
Dynamic Balance	61-00-06 Page 204
Spinner Repair and Chrome Plating	61-00-06 Page 205
Propeller Internal Lubrication.....	61-00-06 Page 205
PROPELLER REMOVAL/INSTALLATION	61-00-06 Page 401
Ground Support Equipment	61-00-06 Page 401
Uncrating and Acceptance Checking a New Propeller	61-00-06 Page 401
Fixed Pitch Propeller Removal and Installation.....	61-00-06 Page 402
Constant Speed Reciprocating Engine Propeller Removal and Installation (Piston)	61-00-06 Page 410
C600/C650/C1100 Series Propeller Removal and Installation	61-00-06 Page 414
C700/C750/C1000 Propeller Removal/Installation.....	61-00-06 Page 419
PROPELLER ADJUSTMENT/TEST	61-00-06 Page 501
Static Balance	61-00-06 Page 501
Propeller Pressure Leakage Check Requirements	61-00-06 Page 501
Ground Support Equipment	61-00-06 Page 501
Flight Idle Blade Angle/Flight Idle Torque Checking and Adjustment Procedures (Turbine Series Propellers)	61-00-06 Page 501
Dynamic Balance	61-00-06 Page 501
PROPELLER INSPECTION/CHECK.....	61-00-06 Page 601
Limitations	61-00-06 Page 601
Definitions of Defects and Damage	61-00-06 Page 601
Daily or Preflight Inspection	61-00-06 Page 602
100 Hour and Annual Inspection.....	61-00-06 Page 603
Time Between Propeller Overhaul	61-00-06 Page 604

McCAULEY PROPELLER SYSTEMS
OWNER/OPERATOR
 INFORMATION MANUAL

Necessary Actions Following Object Strike of Stationary Propeller, Blade Strike of Rotating Propeller, Bird Strike, or Sudden Engine Stoppage	61-00-06 Page 608
Governors Exposed to Propeller Blade Strike, Propeller/Engine Lightning Strike, Engine Detonation, Oil Contamination, or Sudden Engine Stoppage.....	61-00-06 Page 611
Blade Track Check	61-00-06 Page 612
Lightning Strike Inspection Requirements	61-00-06 Page 612
Propeller Overspeed Inspection Requirements	61-00-06 Page 613
Propeller Overtorque Inspection Requirements	61-00-06 Page 613
Normal Criteria for Static Blade Shake and Twist of All Variable Pitch Propellers ..	61-00-06 Page 614
Engine Oil Contamination Inspection Requirements	61-00-06 Page 614
Fire Inspection	61-00-06 Page 616
Non-Destructive Inspection Procedures	61-00-06 Page 616
CLEANING/PAINTING/PROTECTIVE TREATMENTS	61-00-06 Page 701
General	61-00-06 Page 701
Consumable Material	61-00-06 Page 701
Pre-Cleaning Procedures	61-00-06 Page 707
Blade Cleaning	61-00-06 Page 707
Propeller Protective Treatments	61-00-06 Page 707
Blade Painting	61-00-06 Page 708
Spinner Chrome Plating	61-00-06 Page 709
PROPELLER APPROVED REPAIRS	61-00-06 Page 801
Blade Repair	61-00-06 Page 801
Spinner Repair	61-00-06 Page 806
PROPELLER INSTALLATION PARTS LIST	61-00-06 Page 1001
General	61-00-06 Page 1001
DEICE SYSTEM DESCRIPTION AND OPERATION	61-10-40 Page 1
Introduction	61-10-40 Page 1
Applicable Regulations	61-10-40 Page 1
Installation Description	61-10-40 Page 1
Principles Of Operation	61-10-40 Page 1
Deice Systems	61-10-40 Page 1
Types of Deice Systems	61-10-40 Page 3
Description of Deice System Components	61-10-40 Page 3
DEICE SYSTEM - TROUBLESHOOTING	61-10-40 Page 101
Introduction	61-10-40 Page 101
Helpful Hints	61-10-40 Page 101
Trouble Shooting Guide	61-10-40 Page 101
DEICE SYSTEM - REMOVAL/INSTALLATION	61-10-40 Page 401
General	61-10-40 Page 401
Deice Boot Removal and Installation	61-10-40 Page 403
Slip Ring Installation	61-10-40 Page 418
Brush Block Assembly and Mounting Bracket Installation	61-10-40 Page 419
Wiring Harness Or Lead Strap Installation	61-10-40 Page 420
Timer Installation	61-10-40 Page 427
Ammeter, Switch, and Circuit Breaker Installation	61-10-40 Page 427
DEICE SYSTEM - ADJUSTMENT/TEST	61-10-40 Page 501
Introduction	61-10-40 Page 501
Slip Ring Run-Out Test	61-10-40 Page 501
Brush Block Continuity Test	61-10-40 Page 501
DEICE SYSTEM - INSPECTION/CHECK	61-10-40 Page 601
General	61-10-40 Page 601
100 Hour Inspection	61-10-40 Page 601
Deice Boot Resistance Test	61-10-40 Page 604
Slip Ring	61-10-40 Page 605

McCAULEY PROPELLER SYSTEMS
OWNER/OPERATOR
 INFORMATION MANUAL

DEICE SYSTEM - REPAIR	61-10-40 Page 801
Introduction.....	61-10-40 Page 801
Ammeter, Switch, and Circuit Breaker.....	61-10-40 Page 801
Timer	61-10-40 Page 801
Slip Ring Assembly	61-10-40 Page 801
Brush Block and Mounting Bracket Assemblies	61-10-40 Page 802
Deice Boot Replacement	61-10-40 Page 804
ILLUSTRATED PARTS LIST	61-10-40 Page 1001
Illustrated Deice Parts List C400 Series Propellers	61-10-40 Page 1001
Illustrated Deice Parts List C500 Series Propellers	61-10-40 Page 1007
Illustrated Deice Parts List C600 Series Propellers	61-10-40 Page 1012
Illustrated Deice Parts List C650 Series Propellers	61-10-40 Page 1016
Illustrated Deice Parts List C700 Series Propellers	61-10-40 Page 1023
Illustrated Deice Parts List C750 Series Propellers	61-10-40 Page 1028
Illustrated Deice Parts List C1100 Series Propellers	61-10-40 Page 1034
Deice Timers	61-10-40 Page 1041
ANTI-ICE SYSTEM DESCRIPTION AND OPERATION.....	61-10-45 Page 201
Introduction.....	61-10-45 Page 201
Applicable Regulations	61-10-45 Page 201
Installation Description	61-10-45 Page 201
Principles Of Operation	61-10-45 Page 201
Description of Deice System Components	61-10-45 Page 201
Materials Required	61-10-45 Page 202
Propeller Anti-Ice Feed Shoes Removal/Installation	61-10-45 Page 203
Slinger Ring and Feed Nozzle Alignment Check	61-10-45 Page 208
C778 Model Propeller Spray Head Removal and Installation	61-10-45 Page 208
C778 Propeller Anti-Ice Fluid Tubes Removal and Installation	61-10-45 Page 212
Propeller Slinger Ring Assembly Removal and Installation	61-10-45 Page 213
Spinner Bulkhead Assembly Removal and Installation	61-10-45 Page 213
Troubleshooting.....	61-10-45 Page 213
ANTI-ICE SYSTEM - INSPECTION/CHECK.....	61-10-45 Page 601
General	61-10-45 Page 601
100 Hour Inspection.....	61-10-45 Page 601
ANTI-ICE SYSTEM ILLUSTRATED PARTS LIST	61-10-45 Page 1001
Illustrated Anti-Ice Parts List C700 and C750 Series Propellers.....	61-10-45 Page 1001

McCAULEY PROPELLER SYSTEMS
OWNER/OPERATOR
INFORMATION MANUAL

FIXED PITCH PROPELLER DESCRIPTION

1. Metal Fixed Pitch Propellers

- A. The propellers of this model series are manufactured of one-piece anodized aluminum alloy and have a fixed pitch.

NOTE: Some fixed pitch propellers are certified with a defined spacer. Refer to Propeller Installation Parts List, Table 1003, Installation Parts for Fixed Pitch Propellers for the correct part number spacer for each applicable propeller model.

- B. For identification, the hub of each propeller is stamped with the complete model number, serial number, Federal Aviation Agency (FAA) type certificate number, production certification number, and the number of times the propeller has been reconditioned. The complete model number is a combination of the basic model number and suffix numbers to indicate the propeller diameter and pitch.

(1) Propeller Model Designation

- (a) The hub model designation is steel stamped on the forward/camber side/face of the propeller hub.

1 Example of hub model designation:

C1390

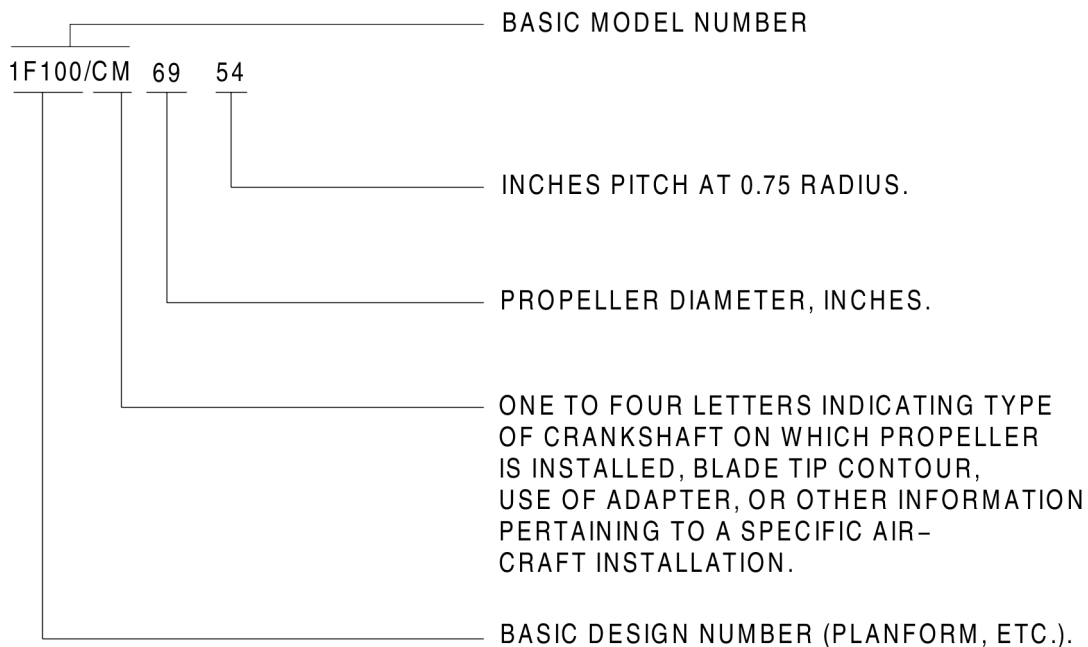

- C. Consult the FAA TC Data Sheets for details relating to approved engine/propeller/airplane installations of fixed pitch propellers covered in this manual.

D. Propeller Mounting Torque

- (1) Refer to Propeller - Removal/Installation for the correct installation instructions and torque values for the propeller mounting hardware.

McCAULEY PROPELLER SYSTEMS
OWNER/OPERATOR
 INFORMATION MANUAL

- E. Propeller Strike or Sudden Engine Stoppage
 - (1) Refer to Necessary Actions Following Object Strike of Stationary Propeller, Blade Strike of Rotating Propeller, Bird Strike, or Sudden Engine Stoppage for the inspection requirements following a propeller "strike" type event.
- F. Lightning Strike
 - (1) Refer to Lightning Strike Inspection Requirements for the inspection requirements following a suspected propeller Lightning strike type event.
- G. Definitions of Propeller Maintenance:
 - (1) Overhaul. This term denotes a complete tear-down and reassembly which is not necessarily applicable to a fixed pitch propeller. The terms "overhaul" and "reconditioning" are sometimes used synonymously for a fixed pitch propeller. The overhaul of a propeller requires the propeller to be inspected for conformity to a fixed set of dimensions and is required on a predetermined interval while reconditioning can occur on an as needed basis.
 - (2) Reconditioning. The repair of blade damage caused by erosion or striking small objects during normal operation. The propeller shall be fluorescent dye penetrant inspected, refinished, and rebalanced. Reconditioning is accomplished on an irregular basis as necessary and required.

NOTE: Refer to Non-Destructive Inspection Procedures for fluorescent dye penetrant inspection procedures.
 - (3) Repair. The correction on an irregular basis as necessary, of damage that has occurred to the propeller. The amount, degree, and extent of damage determines whether or not the propeller can be repaired without refinishing or removing the propeller from the engine. If a propeller is bent or twisted, the repair is major and reconditioning or overhaul of the propeller must be accomplished.
 - (4) Frequency of Overhaul. Refer to Time Between Propeller Overhaul for required propeller overhaul intervals. Propellers shall also be overhauled or repaired as required for blade surface conditions. The propeller mounting bolt torque should be checked at least once a year. Propeller mounting bolts must be magnetic particle inspected in accordance with ASTM E-1444 or replaced whenever the propeller is removed from the engine.

2. Blade Serial Number Stamping Information

- A. Blade serial number information is stamped on the hub. (Refer to Figure 1).

Table 1. Blade Year of Manufacture Code

A = 1980	L = 1991	W = 2002	AH = 2013	AS = 2024
B = 1981	M = 1992	X = 2003	AI = 2014	AT = 2025
C = 1982	N = 1993	Y = 2004	AJ = 2015	AU = 2026
D = 1983	O = 1994	Z = 2005	AK = 2016	AV = 2027
E = 1984	P = 1995	AA = 2006	AL = 2017	AW = 2028
F = 1985	Q = 1996	AB = 2007	AM = 2018	AX = 2029
G = 1986	R = 1997	AC = 2008	AN = 2019	AY = 2030
H = 1987	S = 1998	AD = 2009	AO = 2020	AZ = 2031
I = 1988	T = 1999	AE = 2010	AP = 2021	
J = 1989	U = 2000	AF = 2011	AQ = 2022	
K = 1990	V = 2001	AG = 2012	AR = 2023	

McCAULEY PROPELLER SYSTEMS
OWNER/OPERATOR
 INFORMATION MANUAL

C850

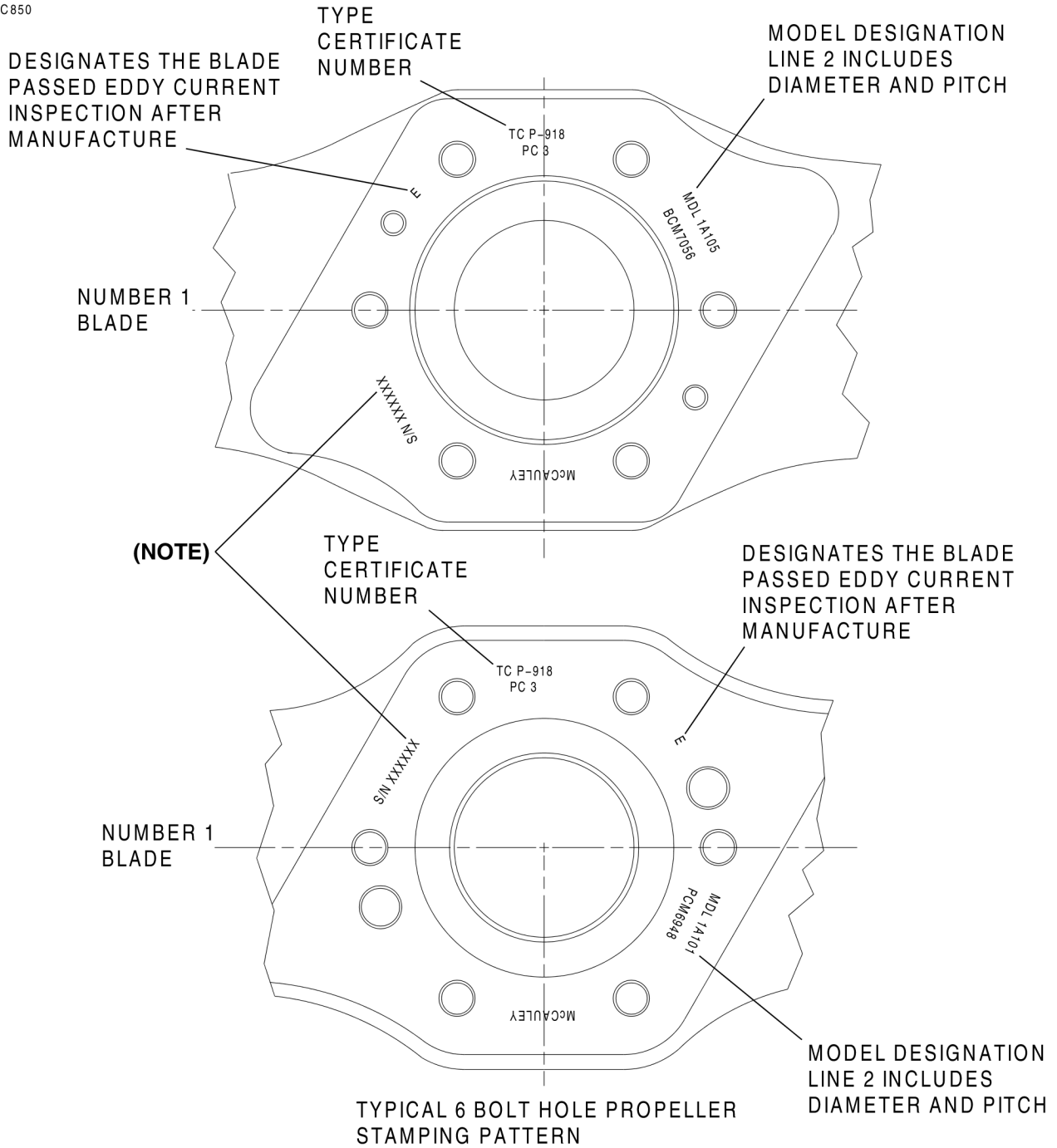

NOTE: STAMPING ARRANGEMENT OR LOCATION OF THE SERIAL NUMBER IS OPTIONAL. LETTERING MAY BE ARCHED OR STRAIGHT, BUT THE SERIAL NUMBER STAMPING IS FOUND AT THE NUMBER 1 BLADE.

0101T1151

Fixed Pitch Blade Stamping
 Figure 1 (Sheet 1)

McCAULEY PROPELLER SYSTEMS
OWNER/OPERATOR
INFORMATION MANUAL

C851

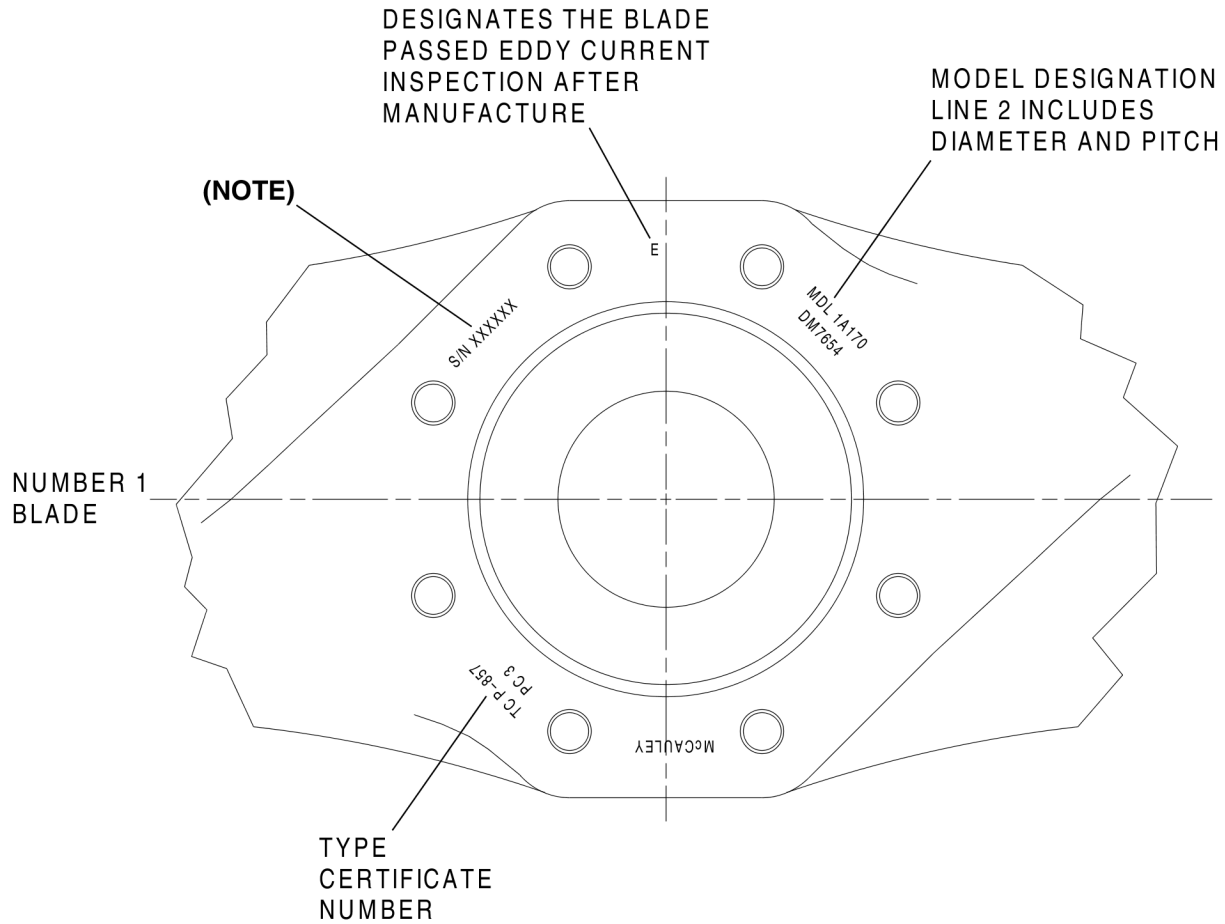

TYPICAL 8 BOLT HOLE PROPELLER
STAMPING PATTERN

NOTE: STAMPING ARRANGEMENT OR LOCATION OF THE SERIAL NUMBER IS OPTIONAL. LETTERING MAY BE ARCHED OR STRAIGHT, BUT THE SERIAL NUMBER STAMPING IS FOUND AT THE NUMBER 1 BLADE.

0101T1152

Fixed Pitch Blade Stamping
Figure 1 (Sheet 2)

McCAULEY PROPELLER SYSTEMS
OWNER/OPERATOR
 INFORMATION MANUAL

Table 2. Blade Month of Manufacture Code

A = January	E = May	I = September
B = February	F = June	J = October
C = March	G = July	K = November
D = April	H = August	L = December

- (1) Blade serial numbers assigned before 1980:
 - (a) Prior to 1980, no calendar date information was encoded in the propeller serial number.
 - (b) Initially, the serial number was a 4 digit number and the numbers were assigned in ascending order.
 - (c) Eventually, the serial number became a 7 digit number.
 - (d) Not all serial numbers are sequential, there are large breaks between assigned propeller serial numbers.
- (2) Blade serial numbers assigned after 1980 and before June 15, 2000:
 - (a) The first letter represents the year of manufacture.
 - (b) The second letter represents the month of manufacture.
 - (c) The following digits represent the number of the blade manufactured during the month of manufacture.
- (3) Blade serial numbers assigned after June 15, 2000:
 - (a) The first or first and second letters represent the year of manufacture.
 - (b) The second, or third, letters represent the month of manufacture.
 - (c) The first two digits represent a reference forging model.
 - (d) The following digits represent the number of the blade manufactured during the month of manufacture.

McCAULEY PROPELLER SYSTEMS
OWNER/OPERATOR
INFORMATION MANUAL

CONSTANT SPEED PROPELLER SYSTEM DESCRIPTION AND OPERATING PRINCIPLES

1. Reciprocating (Piston) Engine Propellers

- A. McCauley propellers for reciprocating engines are of two types: constant speed or constant speed feathering. Each type is provided in either a two-blade or three-blade configuration.
- (1) The C200 Series is a two-blade constant speed propeller. (Refer to Figure 1).
 - (2) The C300 Series is a two-blade constant speed feathering propeller. (Refer to Figure 2).
 - (3) The C400 Series is a three-blade constant speed propeller. (Refer to Figure 3).
 - (4) The C500 Series is a three-blade constant speed feathering propeller. (Refer to Figure 4).
- B. Each propeller consists of a hub assembly, propeller blades, piston and cylinder assembly.
- C. Description of the Propeller Assembly and Deice Components:
- (1) Propeller Hub Assembly - The propeller hub is a single piece, hollow assembly with propeller blade sockets. Each blade socket to blade shank is O-ring sealed to prevent leakage. The rear hub face has threaded studs or bolts for attachment to the engine flange. Some engine flanges have dowels that mate with holes in the hub for alignment. These ensure proper mounting to the engine propeller shaft flange.
 - (2) Propeller Blades - The propeller blades are made of solid forged aluminum. Each is match-balanced to the other blades.
 - (a) The entire propeller assembly is static balanced as well, using balance weights mounted with screws to the blades or the cylinder balance ring.
 - (3) Blade Retention - A set of split retainers (inside the hub) secures each blade in the hub at the blade sockets. During pitch change, each blade rotates about its axis on a bearing assembly. An actuating pin assembly is secured to the blade butt of each blade (inside the hub) by screws. The actuating pin is driven by a link assembly attached to the piston yoke inside the hub cavity.
 - (4) Piston and Cylinder Assembly - Oil pressure, controlled by the propeller governor, and an internal spring act on the piston to provide the forces necessary to accomplish propeller blade pitch changes. The cylinder is mounted to the hub face with screws and is sealed to prevent leakage.
 - (5) Counterweight - Feathering type propellers have counterweights attached to the blades to assist the rotation of the blade to the feathered position.
 - (6) Internal Lubrication - On some models, grease is applied to the bearings for lubrication when the propeller is assembled. However, on other models the lubrication medium is oil. On oil-filled propellers, the hub cavity is partially filled with red dyed engine type oil which is sealed in the hub and isolated from engine oil. This oil provides lubrication and corrosion protection to blade bearings and other internal parts. The oil is dyed red to aid in the troubleshooting of suspected propeller leaks.

NOTE: Periodic field maintenance of this lubrication is NOT normally required.

- D. Description of Piston Engine Propeller Operating Principles
- (1) The C200 and C400 series propellers are constant speed type. They are a single-acting unit in which hydraulic pressure works against the forces of springs and the natural centrifugal moment of the rotating blade to provide the correct pitch for engine load. Hydraulic pressure causes the blades to move toward high pitch (decreasing rpm). The springs and centrifugal moments urge blades toward low pitch (increasing rpm).
 - (2) The C300 and C500 series propellers are constant speed and full-feathering type. They are a single-acting unit in which hydraulic pressure works against the forces of springs and counterweights to provide the correct pitch for engine load. Hydraulic pressure causes the blades to move toward low pitch (increasing rpm). The springs and counterweights urge blades toward high pitch (decreasing rpm).
- E. Propeller Deice (Refer to Figure 11)

NOTE: Only components sold by McCauley are described. Some OEMs or STC owners may have different designs.

- (1) If propeller deice is installed, the components include:
 - electrically heated rubber boots

McCAULEY PROPELLER SYSTEMS
OWNER/OPERATOR
 INFORMATION MANUAL

C320

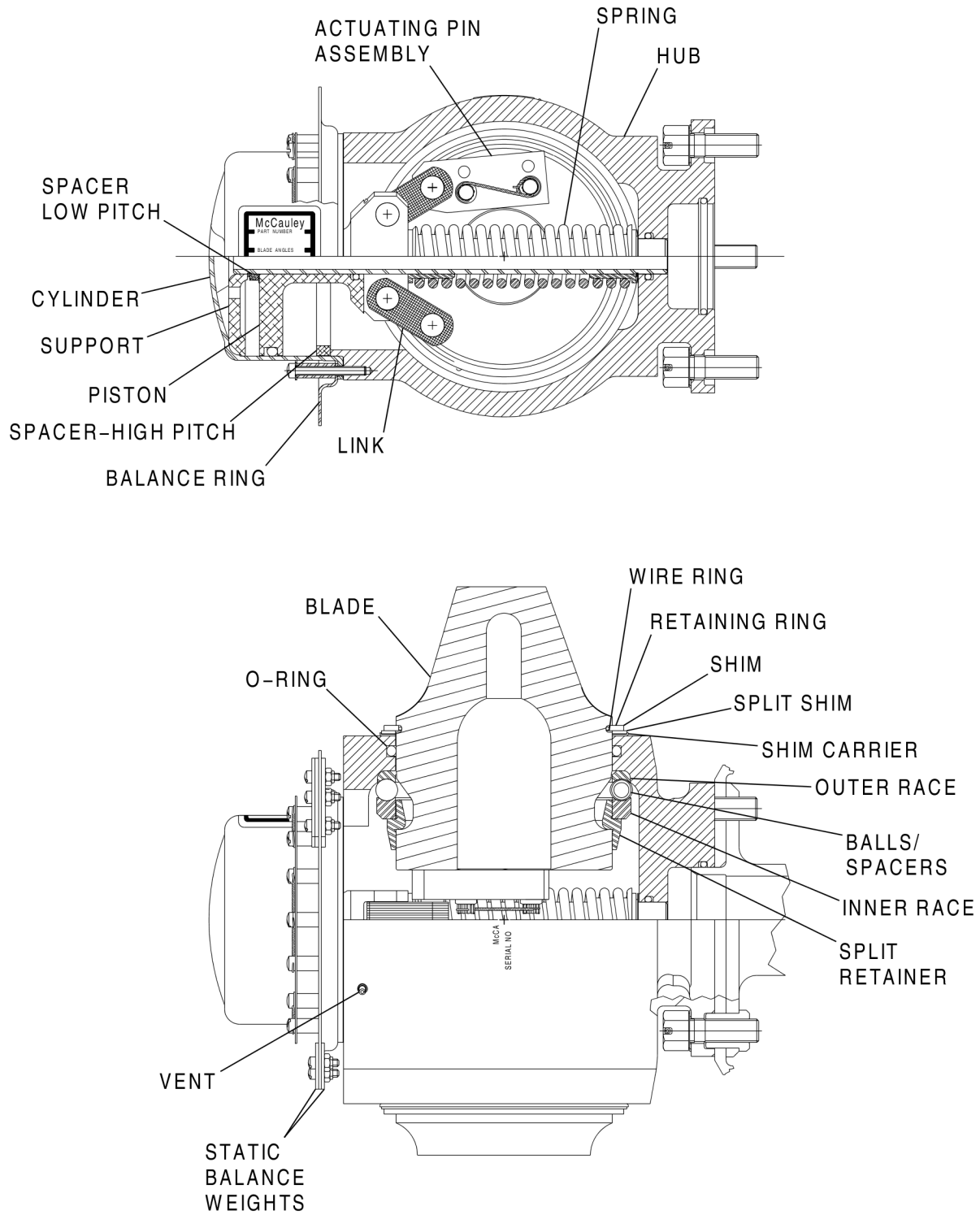

0102T1004

C200 Series Propeller
 Figure 1 (Sheet 1)

McCAULEY PROPELLER SYSTEMS
OWNER/OPERATOR
 INFORMATION MANUAL

C336

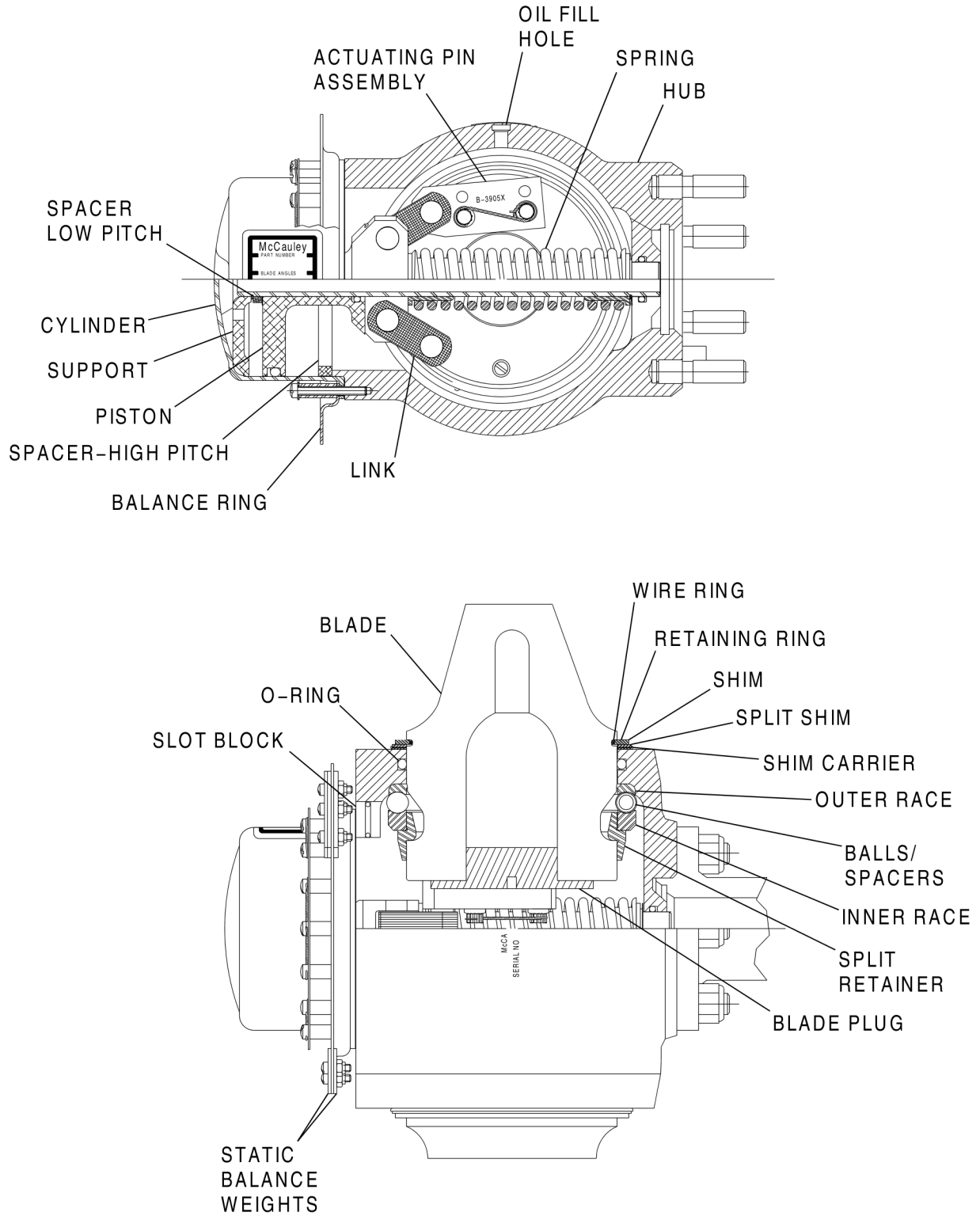

0102T1004

C200 Series Propeller
 Figure 1 (Sheet 2)

McCAULEY PROPELLER SYSTEMS
OWNER/OPERATOR
 INFORMATION MANUAL

C319

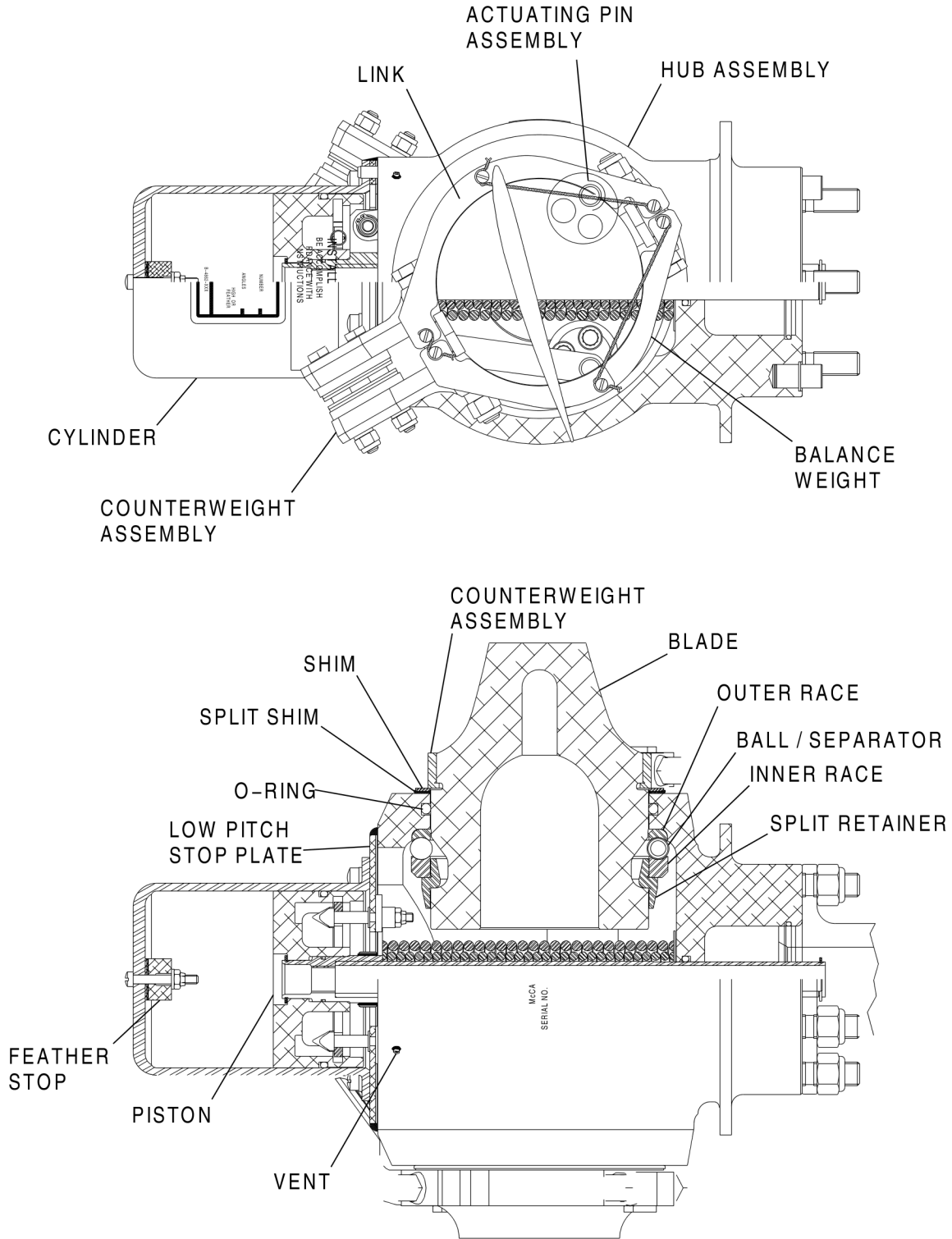

0102T1020

C300 Series Propeller (Non Oil-Filled)
 Figure 2 (Sheet 1)

McCAULEY PROPELLER SYSTEMS
OWNER/OPERATOR
 INFORMATION MANUAL

C1190

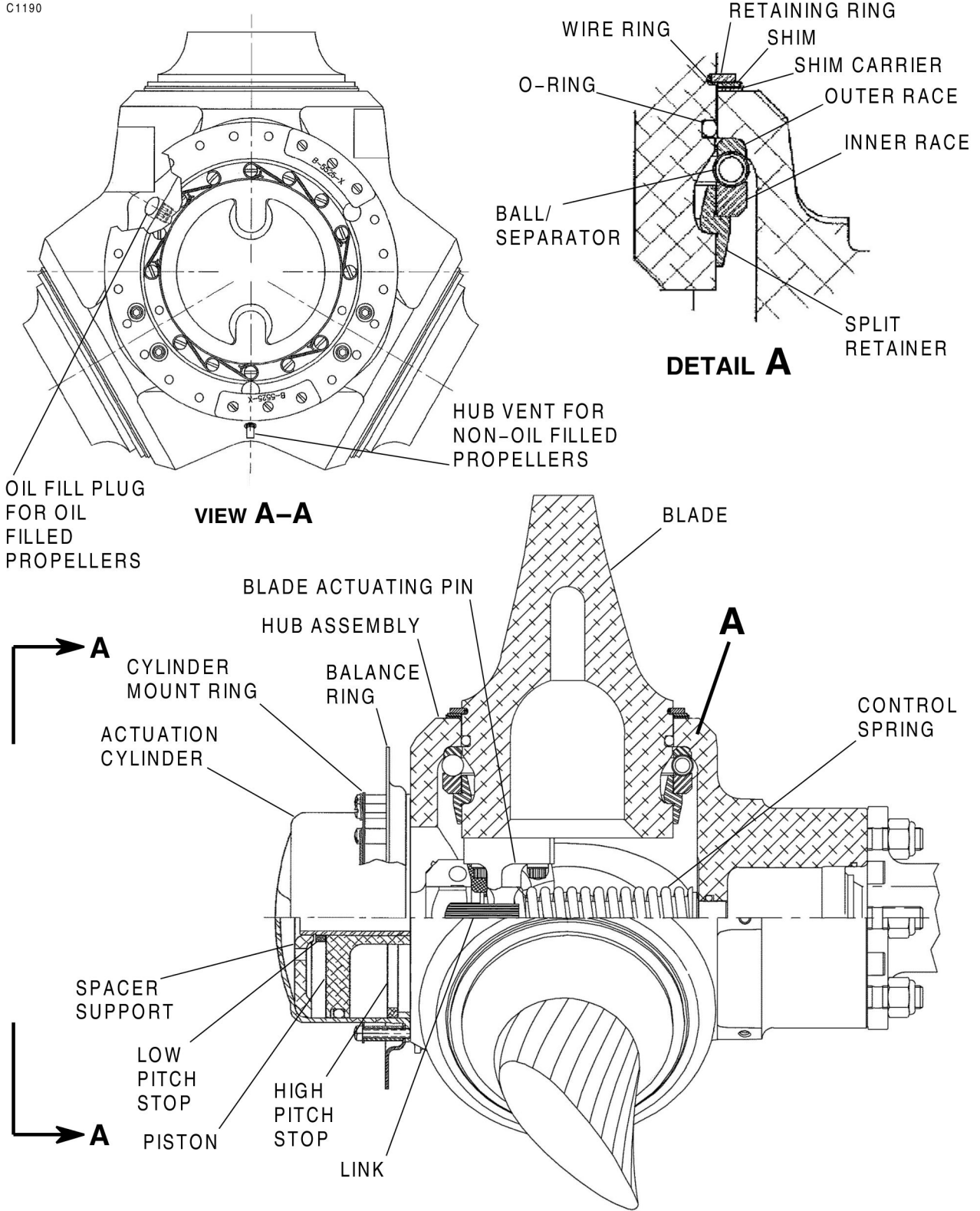

C400 Series Propeller
 Figure 3 (Sheet 1)

McCAULEY PROPELLER SYSTEMS
OWNER/OPERATOR
 INFORMATION MANUAL

C1191

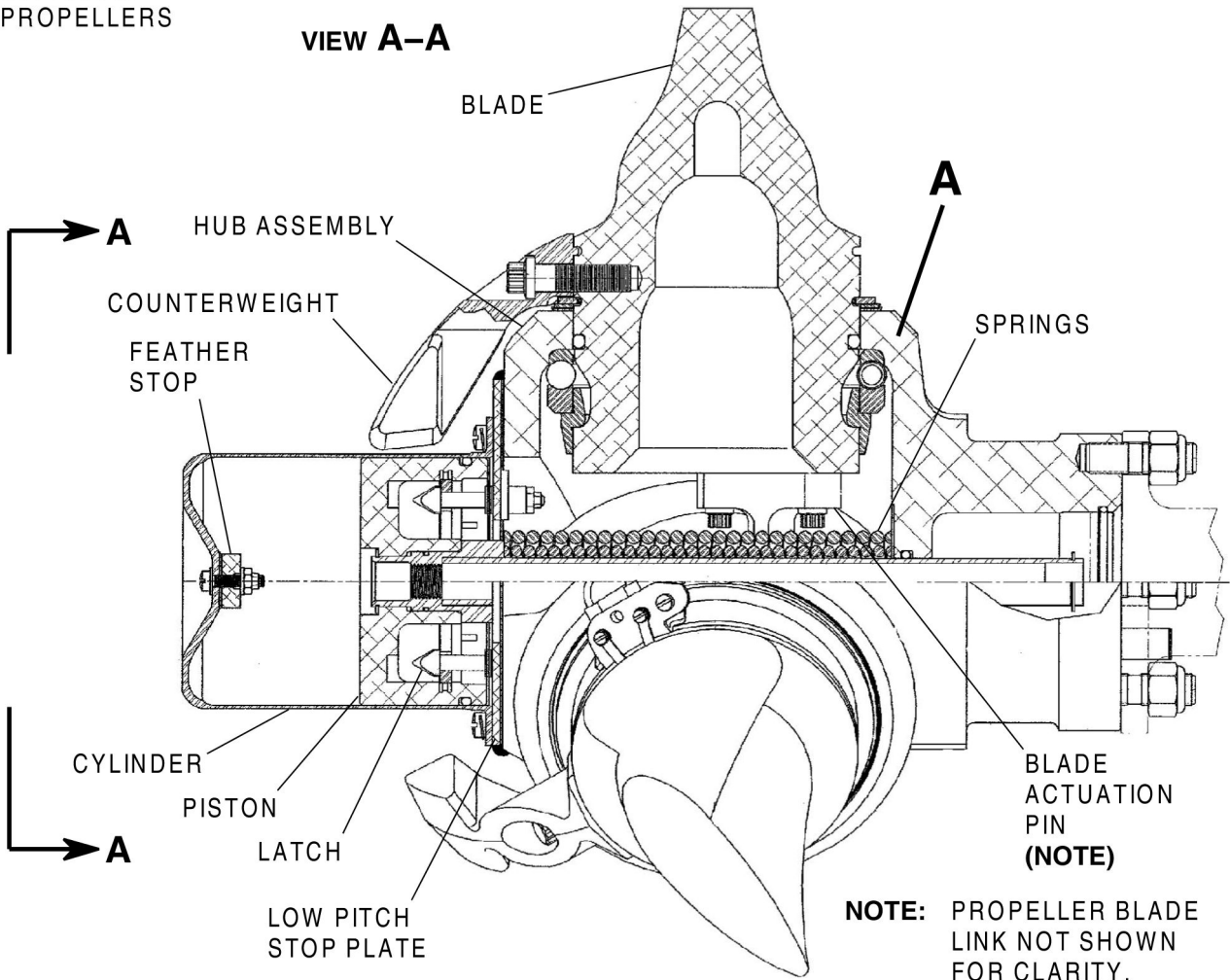
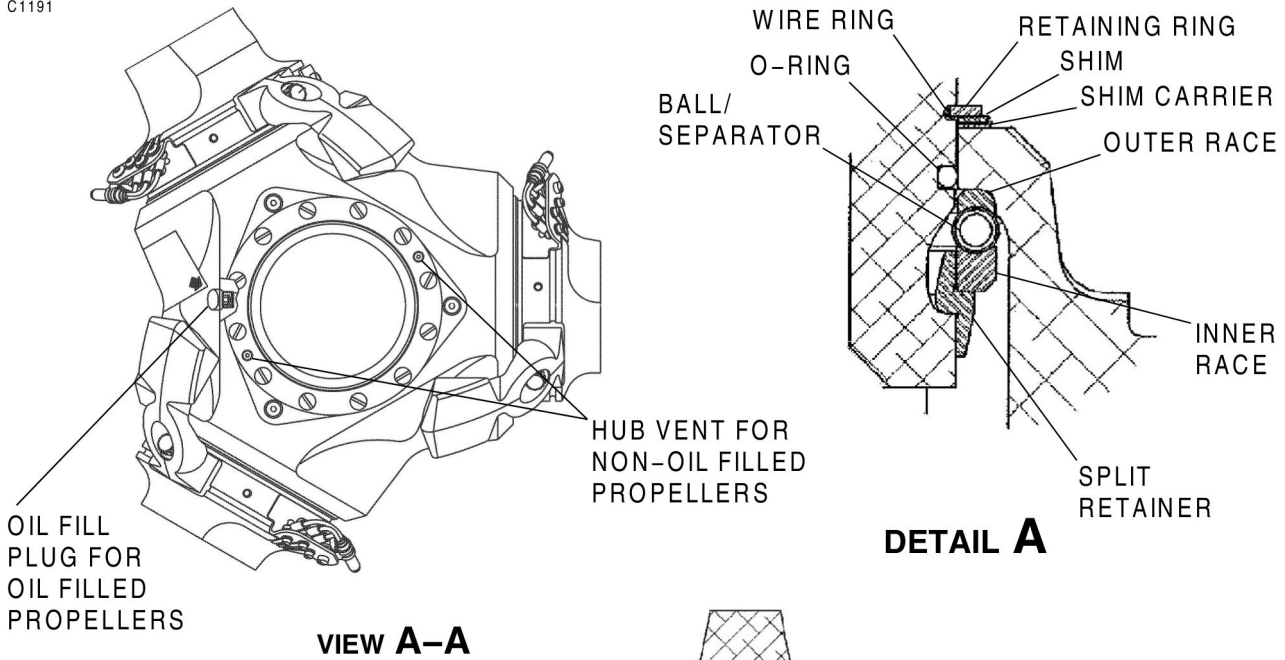

C500 Series Propeller
 Figure 4 (Sheet 1)

McCAULEY PROPELLER SYSTEMS
OWNER/OPERATOR
INFORMATION MANUAL

- deice harnesses
 - slip ring assembly
 - deice timer
 - brush block assembly
- (a) The brush block, deice harnesses, and slip ring assembly conduct electrical power to the propeller blade deice boot elements which then heat.
- (b) The heat melts a layer of the ice which allows the remaining ice to be removed from the propeller blades by centrifugal force.
- F. Propeller Anti-Ice (Refer to Figure 11)
- (1) If propeller alcohol anti-ice is installed, the components include:
- slinger ring assembly
 - spray head assembly
 - propeller blade feed shoe
- (a) The slinger ring distributes anti-ice fluid from the fluid reservoir to the spray head assembly for each propeller blade. Anti-ice fluid is pumped into the rotating slinger ring and the centrifugal force of the rotating slinger ring forces the anti-ice fluid to flow to the spray head assemblies.
- (b) The spray head assembly transports the anti-ice fluid from the slinger ring to the propeller blade feed shoe. The spray head distributes the anti-ice fluid across the grooves that are imbedded in the propeller blade feed shoes.
- (c) The propeller blade feed shoe is attached to the leading edge of each propeller blade. The feed shoes are made of rubber and have grooves to guide/feed anti-ice fluid (alcohol) along the leading edge of the rotating propeller by centrifugal force. The alcohol that is distributed on the feed shoe and adjacent blade surface prevents the formation of ice on the propeller blades.
- G. Propeller Deice Boots/Alcohol Anti-Ice Feed Shoes (if installed).
- (1) The deice boots are constructed of fabric-reinforced, abrasion-resistant rubber. Electrical deice boots have a wire mesh or foil element that heats as current is supplied to the boot. A deice timer controls the current cycle that is applied to individual blades or boot segments. Alcohol anti-ice feed shoes are ridged for distribution of alcohol. The outer surface that is exposed to the environment has a glossy finish, while the side that is bonded to the propeller has a dull, matte finish.
- H. Deice Harness (if deice is installed) - The deice electrical harnesses connect the deice boots to the slip ring assembly to complete the deice electrical circuit.
- I. Deice Slip Ring Assembly (if deice is installed) - The deice slip ring assembly is constructed of machined aluminum with bronze commutator rings bonded to one side. Studs to attach the deice leads for each blade are located on the propeller side of the platter. These are brazed to the commutator rings and pass through holes provided for that purpose. Slip ring assemblies may be secured to the hub, to the starter ring gear, or the alternator belt drive pulley.

2. Turbine Engine Propellers

- A. Turbine Engine Propeller Component Description
- (1) McCauley C600 model series propellers have three propeller blades, C650 model series propellers have four propeller blades, C1100 model series propellers have five propeller blades. Each propeller consists of a hub assembly, propeller blades, piston and cylinder assembly, blade start locks, counterweights, a spinner, and spinner bulkhead assembly. (Refer to Figure 5, Figure 6 and Figure 10.)
- (a) The McCauley C600, C650, and C1100 model series propellers are used on Honeywell (Garrett) turbine engines.
- (2) McCauley C700 model series propellers have three propeller blades, C750 model series propellers have four propeller blades, C1000 model series propellers have five propeller blades. Each propeller consists of a hub assembly, propeller blades, piston and cylinder assembly, counterweights and beta shift mechanisms. (Refer to Figure 7, Figure 8 and Figure 9.)
- (a) The McCauley C700, C750 and C1000 model series propellers are used on Pratt and Whitney turbine engines.

McCAULEY PROPELLER SYSTEMS
OWNER/OPERATOR
INFORMATION MANUAL

- (3) Following is a breakdown of each of the propeller assemblies:
- (a) Propeller Hub Assembly
 - 1 The propeller hub is a single-piece hollow forged aluminum assembly incorporating three, four or five propeller blade sockets. The propeller blade sockets are O-ring sealed to prevent leakage. The rear hub face has threaded studs and dowel holes for alignment and proper mounting to the engine propeller shaft flange. The cylinder is mounted to the hub face using screws and is O-ring sealed to prevent leakage.
 - (b) Propeller Blades
 - 1 The propeller blades are made of solid forged aluminum. A set of steel split retainers (inside the hub) secures each blade in the hub at the propeller blade sockets. Each blade rotates about its axis on a bearing assembly during pitch change and is match-balanced to the other blades. The propeller assembly is static balanced, using balance weights mounted with screws to the blades.
 - (c) Piston and Cylinder Assembly
 - 1 The piston and cylinder assembly (through the feather springs, counterweights, and oil pressure transferred through the piston rod) provide the forces necessary to accomplish propeller blade pitch changes.
 - (d) Counterweights
 - 1 Counterweights are attached to the blades to assist the feathering spring (located in front of the piston and cylinder assembly) in feathering the propeller blades by means of centrifugal force whenever the propeller is rotating and oil pressure in the cylinder is removed.
 - (e) Internal Lubrication
 - 1 The propeller hub cavity is partially filled with turbine oil which is sealed in the hub and isolated from engine oil. This oil provides lubrication and corrosion protection to blade bearings and other internal parts. The oil is dyed red on some models to aid in the troubleshooting of suspected propeller leaks.

NOTE: Periodic maintenance of the lubrication is NOT normally required.

- (f) Propeller Start Lock (C600, C650, and C1100 Series only).
 - 1 The propeller has a start lock mechanism installed within the cylinder. The mechanism includes latching weights which will engage a fixed stop to block movement of the piston in the direction of increasing blade pitch beyond a predetermined start lock blade angle. Latch engagement is possible only when the engine is shut off on the ground. When the propeller is rotating, the latch weights move out by centrifugal force so as to offer no interference to operation of the control system in flight. During all normal operating conditions, the weights are in a disengaged position and offer no resistance to feathering, unfeathering, or reversing of the propeller.

NOTE: Special tools (McCauley part number B-5021/2) are required to release start locks manually for maintenance purposes.

- B. Description of Turbine Propeller Operating Principles
 - (1) Propellers are a single acting unit in which hydraulic pressure opposes the forces of springs and counterweights to obtain the correct pitch for engine load. Hydraulic pressure urges blades toward low pitch (increasing RPM), while springs and counterweights urge blades toward high pitch (decreasing RPM).
- C. The propeller is designed to operate in two modes of operation - beta mode and governor mode:
 - (1) Governor Mode - Oil is metered to and from the propeller (by governor control valve as positioned by flyweights), increasing and decreasing blade angle (changing pitch) as required when the propeller speed control setting is altered, or increasing and decreasing pitch to control and stabilize engine speed with varying power conditions or flight attitudes with a fixed speed setting.
 - (2) Beta Mode - The pilot may select beta mode for ground reversing or taxi operation by means of the aircraft engine mechanical linkage. The linkage repositions the propeller reversing lever and beta valve to provide access for high pressure oil to reach the propeller piston and move the blades toward reverse pitch.

McCAULEY PROPELLER SYSTEMS
OWNER/OPERATOR
 INFORMATION MANUAL

C1192

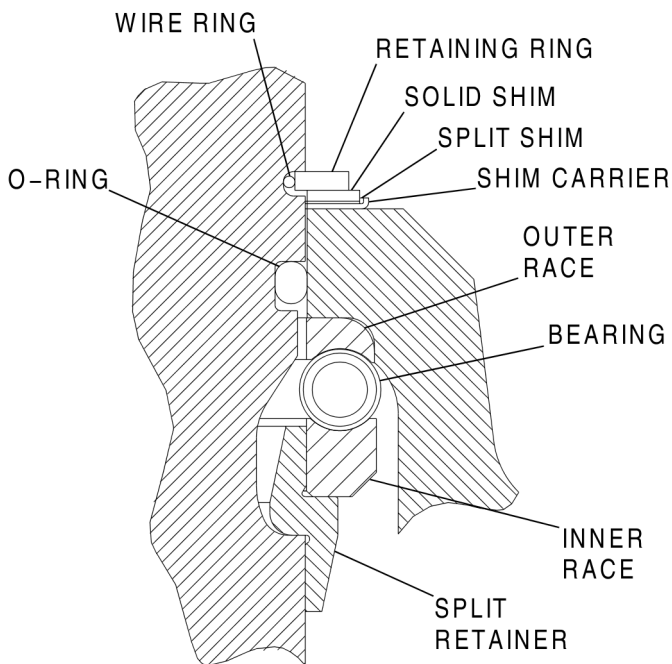
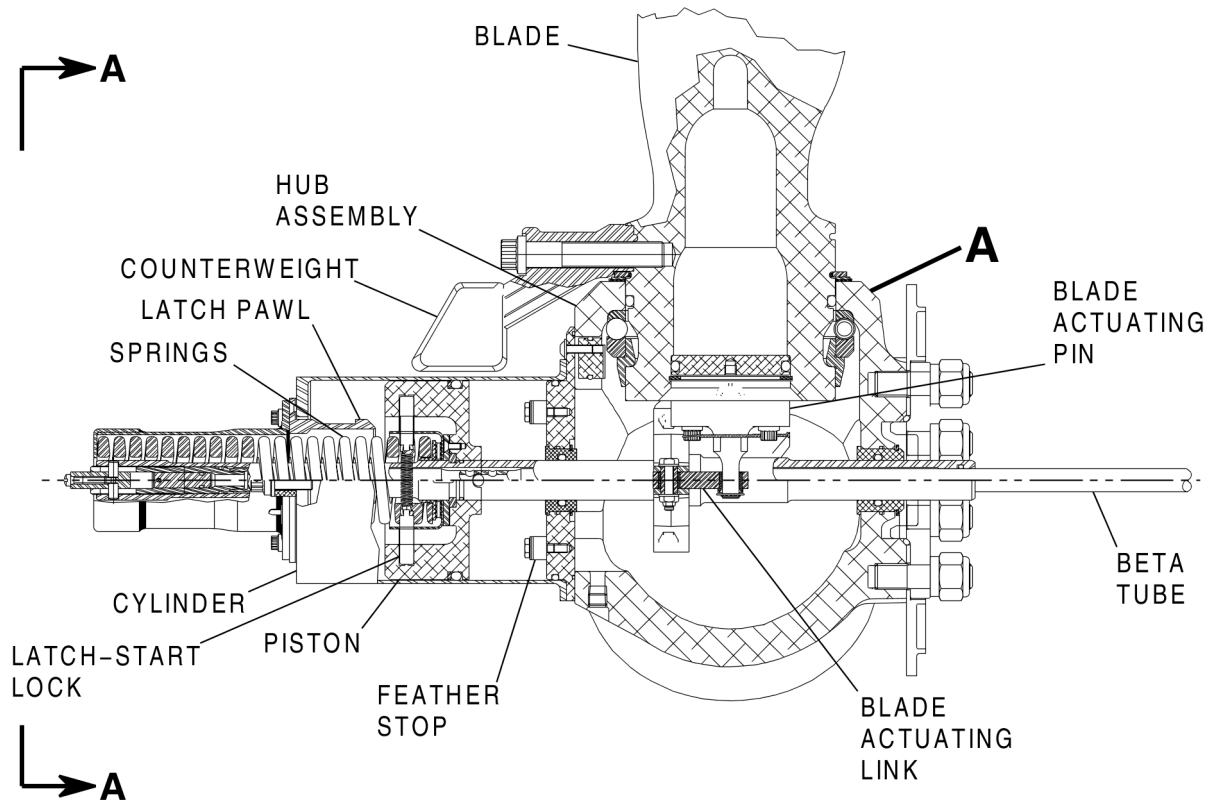

DETAIL A

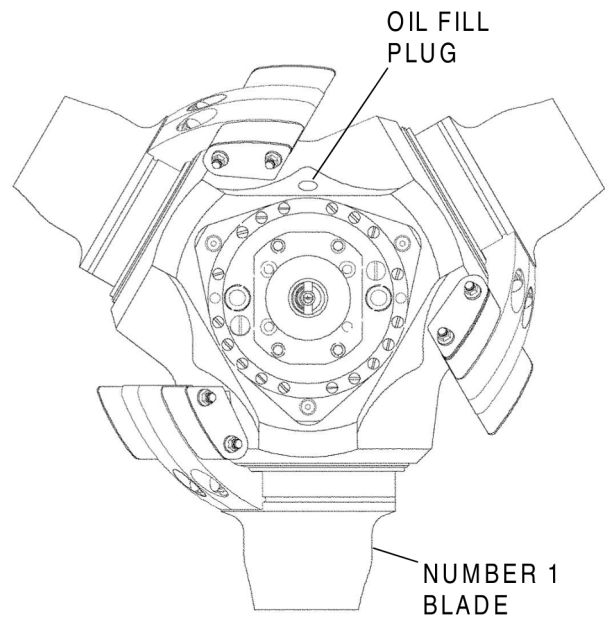

VIEW A-A

0101T1050

C600 Series Propeller
 Figure 5 (Sheet 1)

McCAULEY PROPELLER SYSTEMS
OWNER/OPERATOR
 INFORMATION MANUAL

C1193

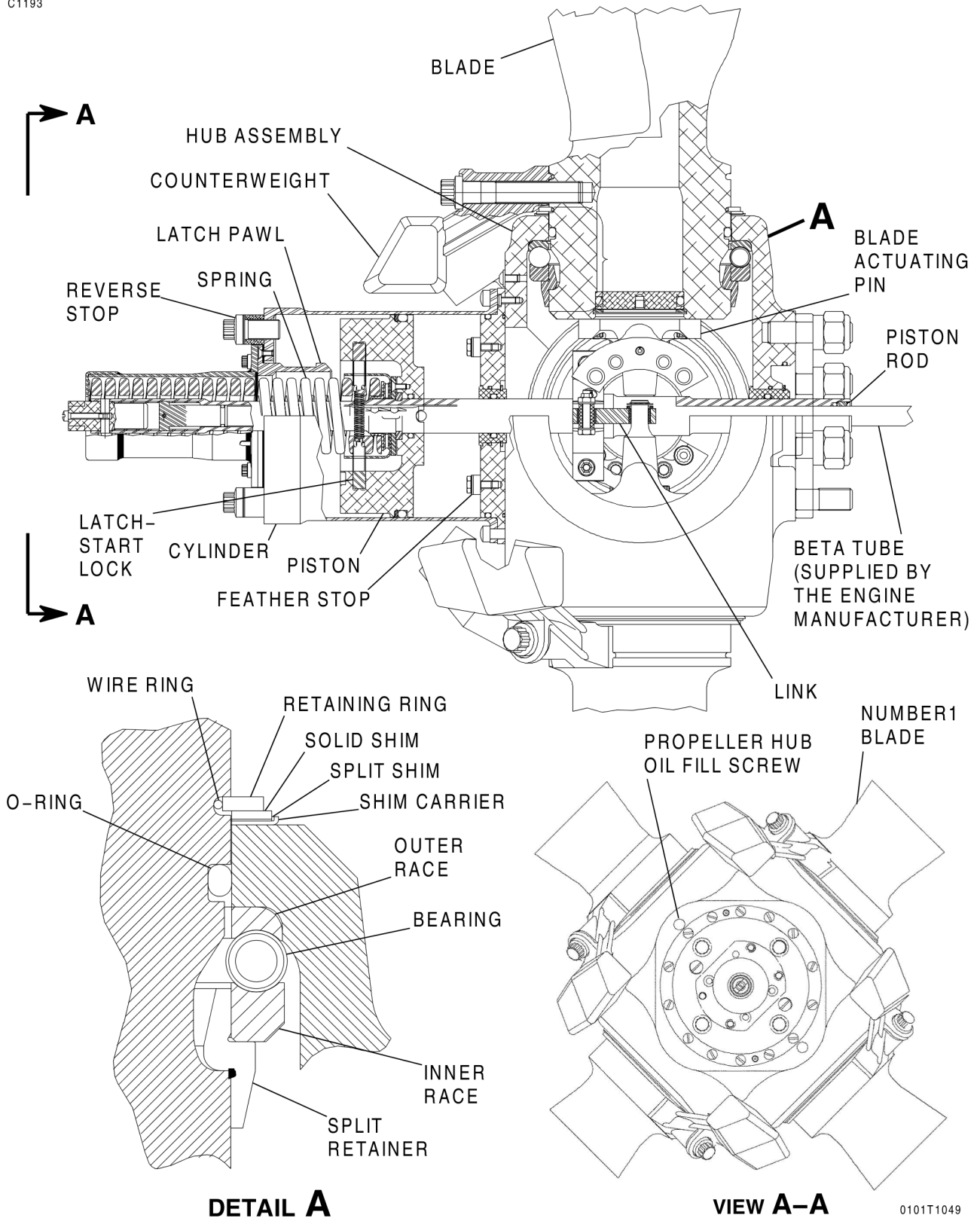

C650 Series Propeller
 Figure 6 (Sheet 1)

McCAULEY PROPELLER SYSTEMS
OWNER/OPERATOR
 INFORMATION MANUAL

C1194

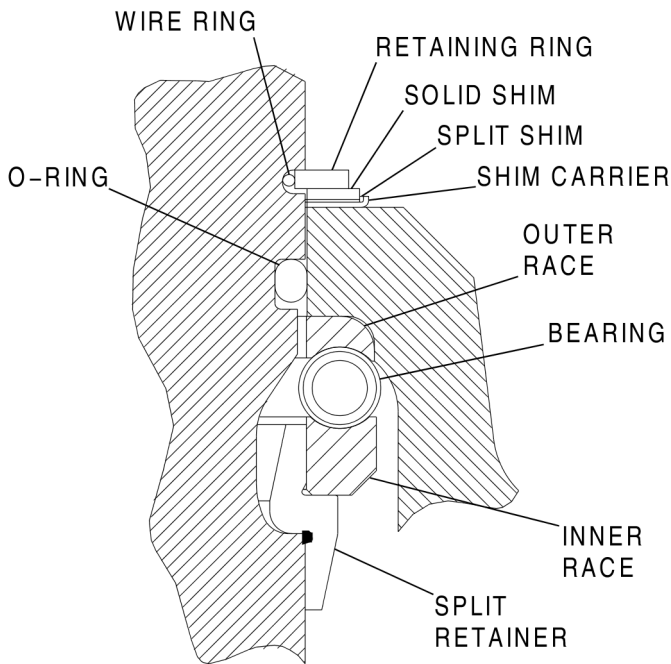
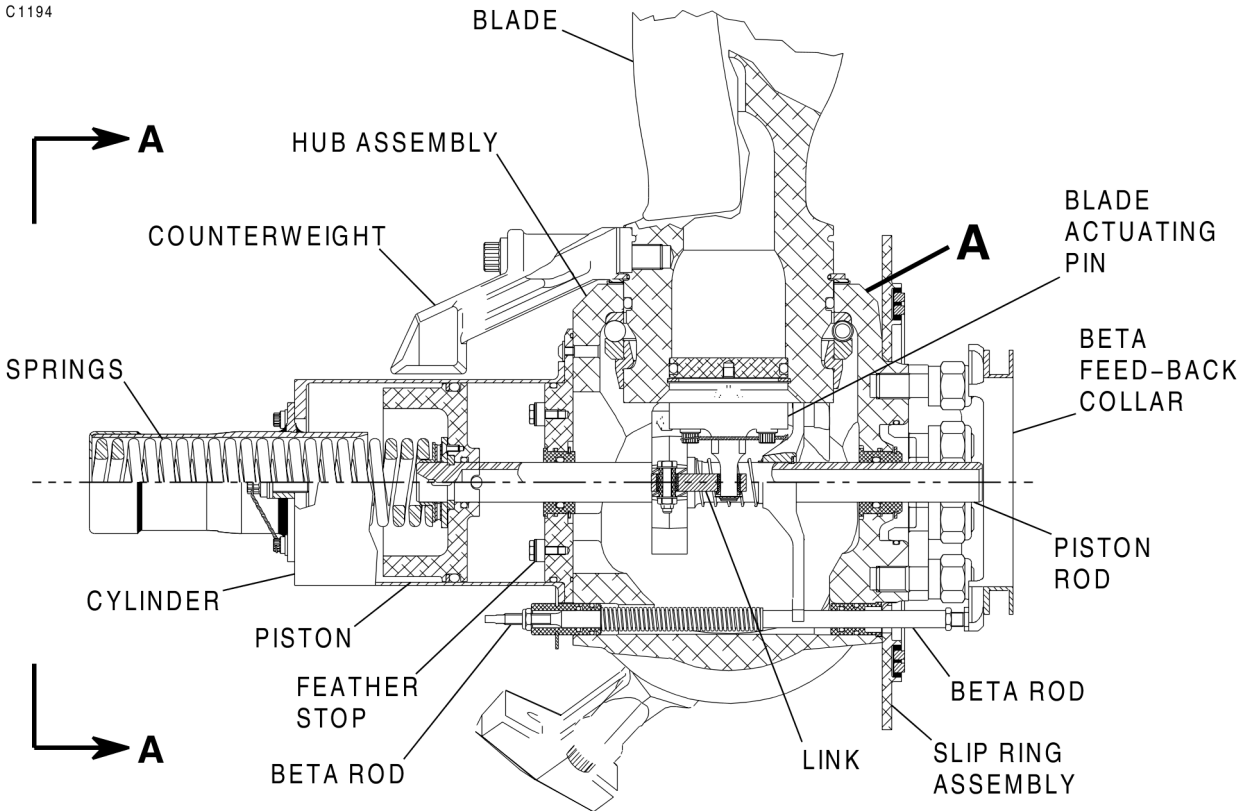

DETAIL A

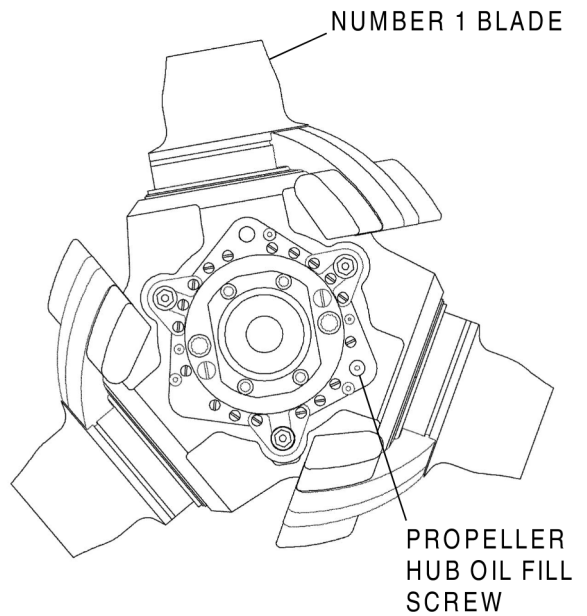

VIEW A-A

0101T1051

C700 Series Propeller
 Figure 7 (Sheet 1)

McCAULEY PROPELLER SYSTEMS
OWNER/OPERATOR
 INFORMATION MANUAL

C1195

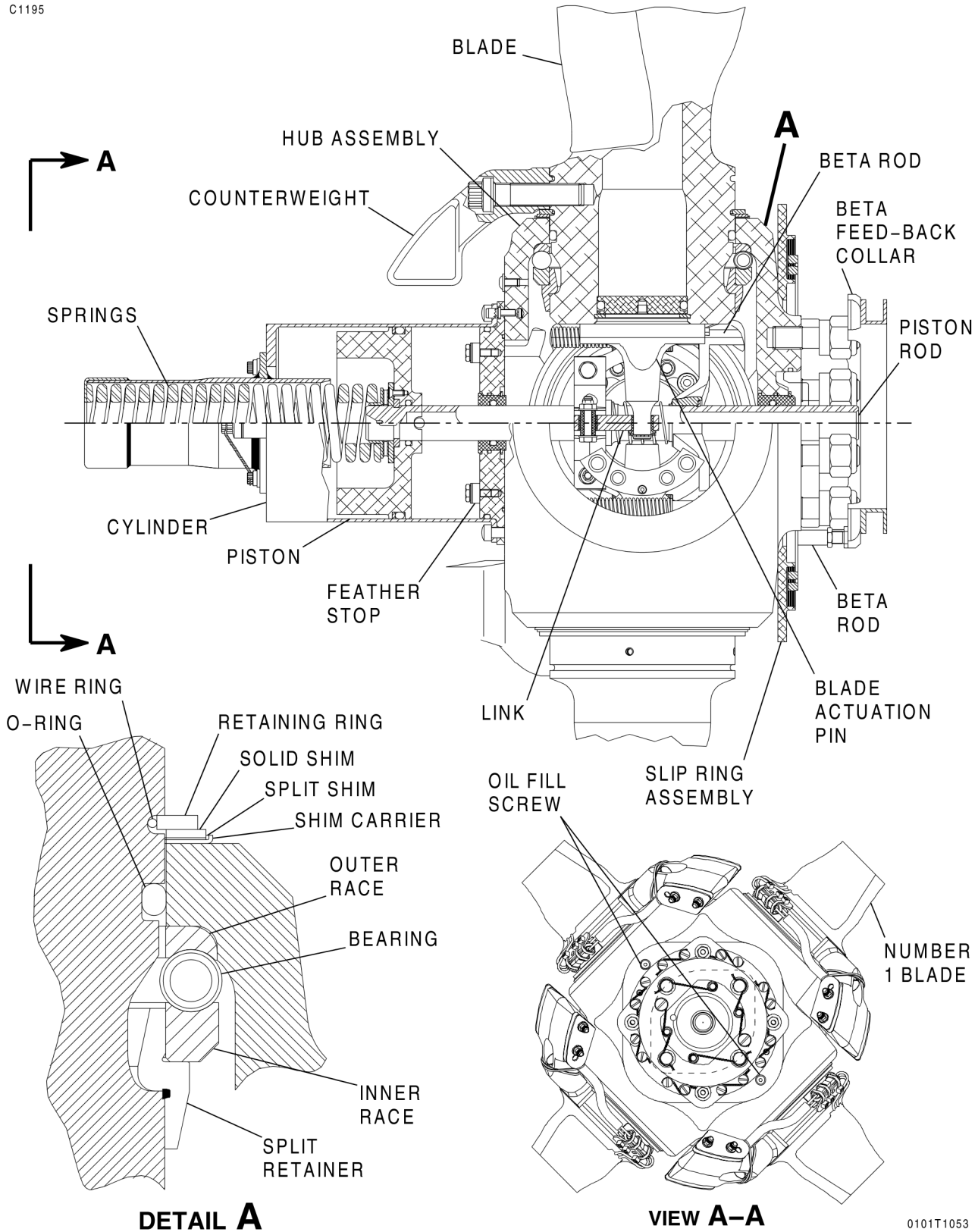

C750 Series Propeller
 Figure 8 (Sheet 1)

0101T1053

McCAULEY PROPELLER SYSTEMS
OWNER/OPERATOR
 INFORMATION MANUAL

C1050

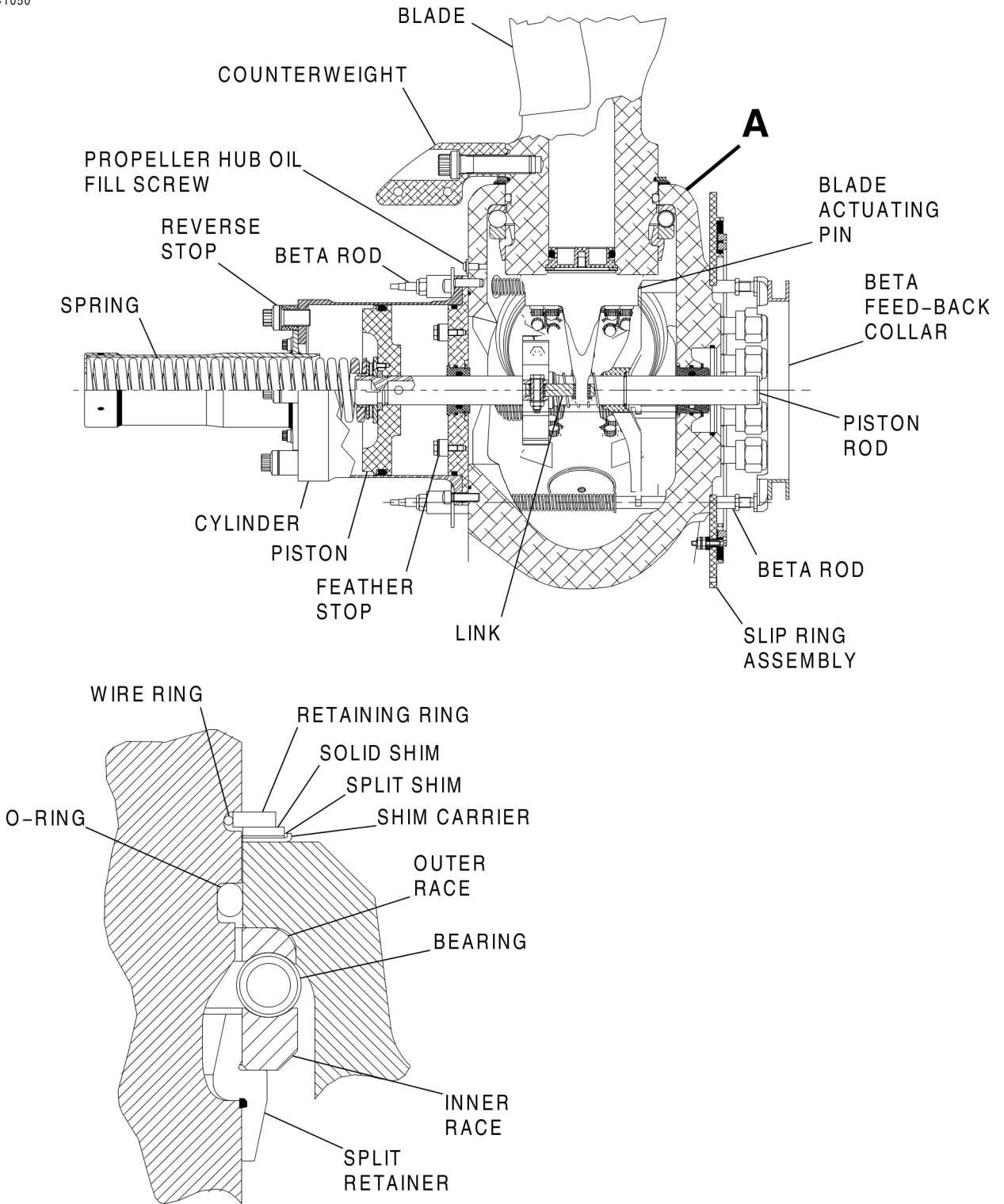

DETAIL A

0102T1075

C1000 Series Propeller
 Figure 9 (Sheet 1)

McCAULEY PROPELLER SYSTEMS
OWNER/OPERATOR
 INFORMATION MANUAL

C1196

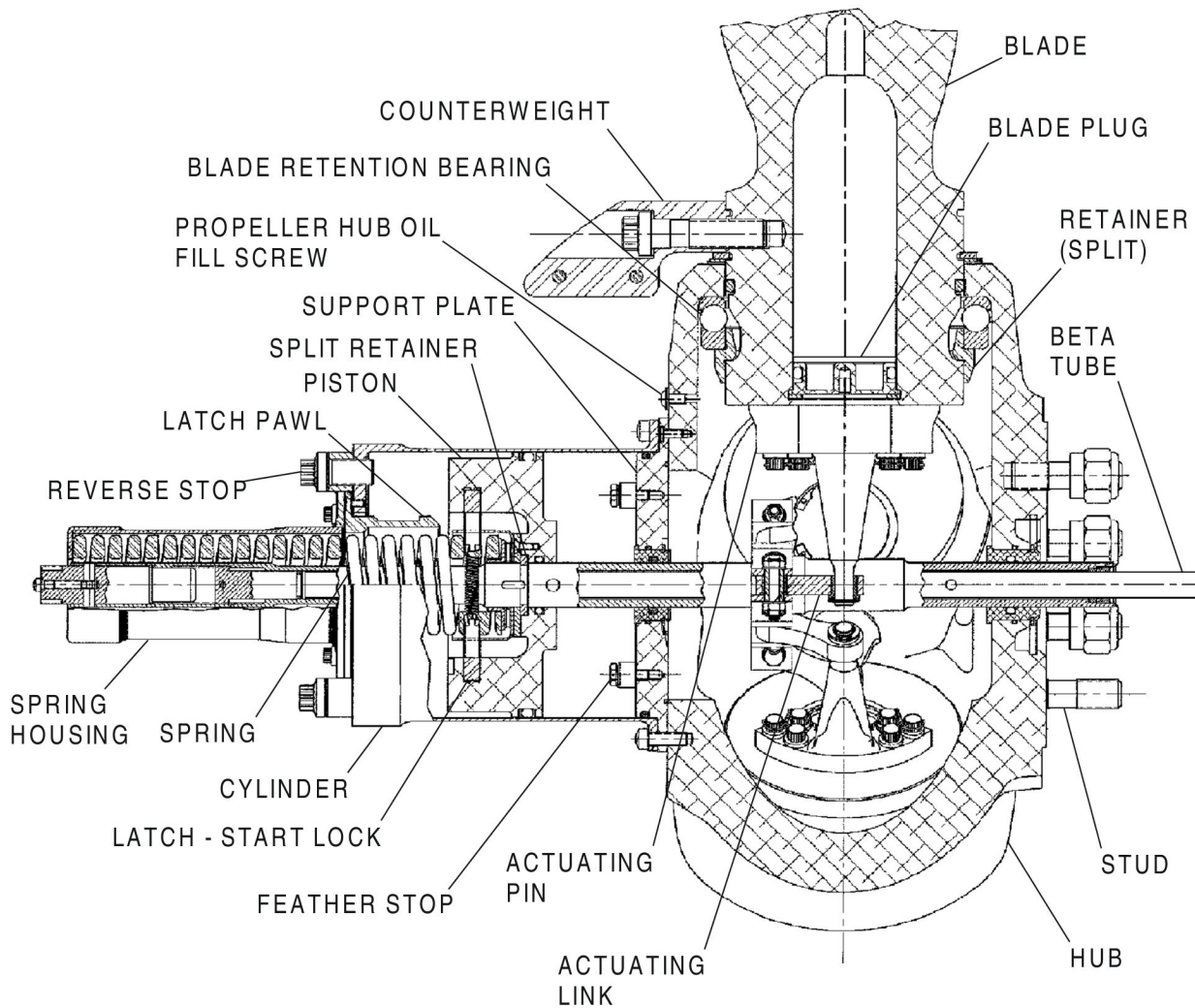

PROPELLER SECTIONAL DRAWING
 C1105

NOTE: THE OIL FLOW (BETA) TUBE IS FURNISHED BY ENGINE MANUFACTURER.

C1100 Series Propeller
 Figure 10 (Sheet 1)

McCAULEY PROPELLER SYSTEMS
OWNER/OPERATOR
INFORMATION MANUAL

D. Propeller Deice, refer to Figure 11.

NOTE: Only components sold by McCauley are described. Some OEMs or STC owners may have different designs.

(1) If propeller deice is installed, the components include:

- electrically heated rubber boots
- deice harnesses
- slip ring assembly
- deice timer
- brush block assembly

- (a) The brush block, deice harnesses, and slip ring assembly conduct electrical power to the propeller blade deice boot elements which then heat.
- (b) The heat melts a layer of the ice which allows the remaining ice to be removed from the propeller blades by centrifugal force.
- (c) Deice Harness (if deice is installed) - The deice electrical harnesses connect the deice boots to the slip ring assembly to complete the deice electrical circuit.
- (d) Deice Slip Ring Assembly (if deice is installed) - The deice slip ring assembly is constructed of machined aluminum with bronze commutator rings bonded to one side. Studs to attach the deice leads for each blade are located on the propeller side of the platter. These are brazed to the commutator rings and pass through holes provided for that purpose. Slip ring assemblies are secured to the hub or are sandwiched between the hub and the engine flange.

3. Overhaul Period

A. All propellers are to be overhauled at specific intervals. Refer to Time Between Propeller Overhaul for required propeller overhaul intervals. Propellers shall also be overhauled or repaired as required for blade surface conditions.

4. Propeller Model Designation

A. McCauley uses a model designation system to identify specific propellers. This is done by utilizing a combination of hub and blade model designations.

B. Hub Model Designation.

(1) The hub model designation is steel stamped on the propeller hub. Examples of hub model designation:

McCAULEY PROPELLER SYSTEMS
OWNER/OPERATOR
 INFORMATION MANUAL

C1199

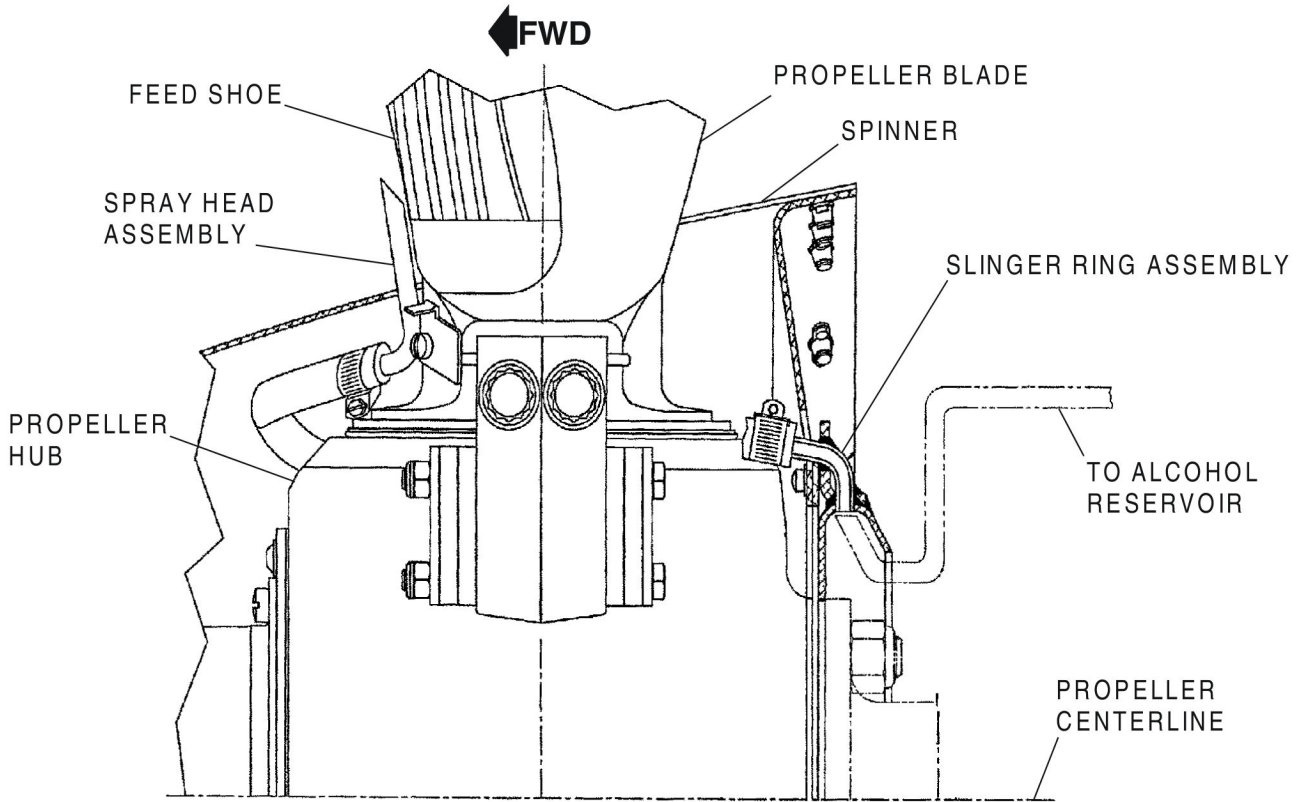
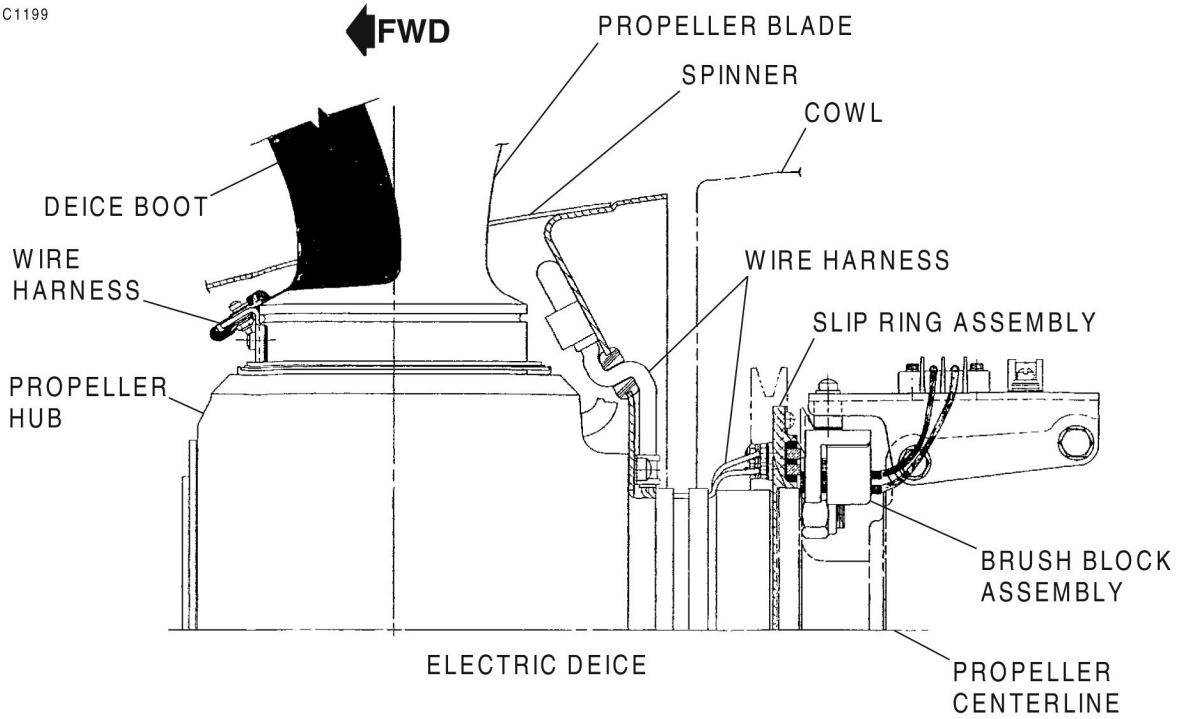

ALCOHOL ANTI-ICE
 Propeller Deice/Anti-Ice Installation
 Figure 11 (Sheet 1)

McCAULEY PROPELLER SYSTEMS
OWNER/OPERATOR
INFORMATION MANUAL

C1030

[X]3AF32C517-[X]- SAMPLE PISTON ENGINE HUB MODEL DESIGNATION

[X] 3 A F 32 C 517 -[X]

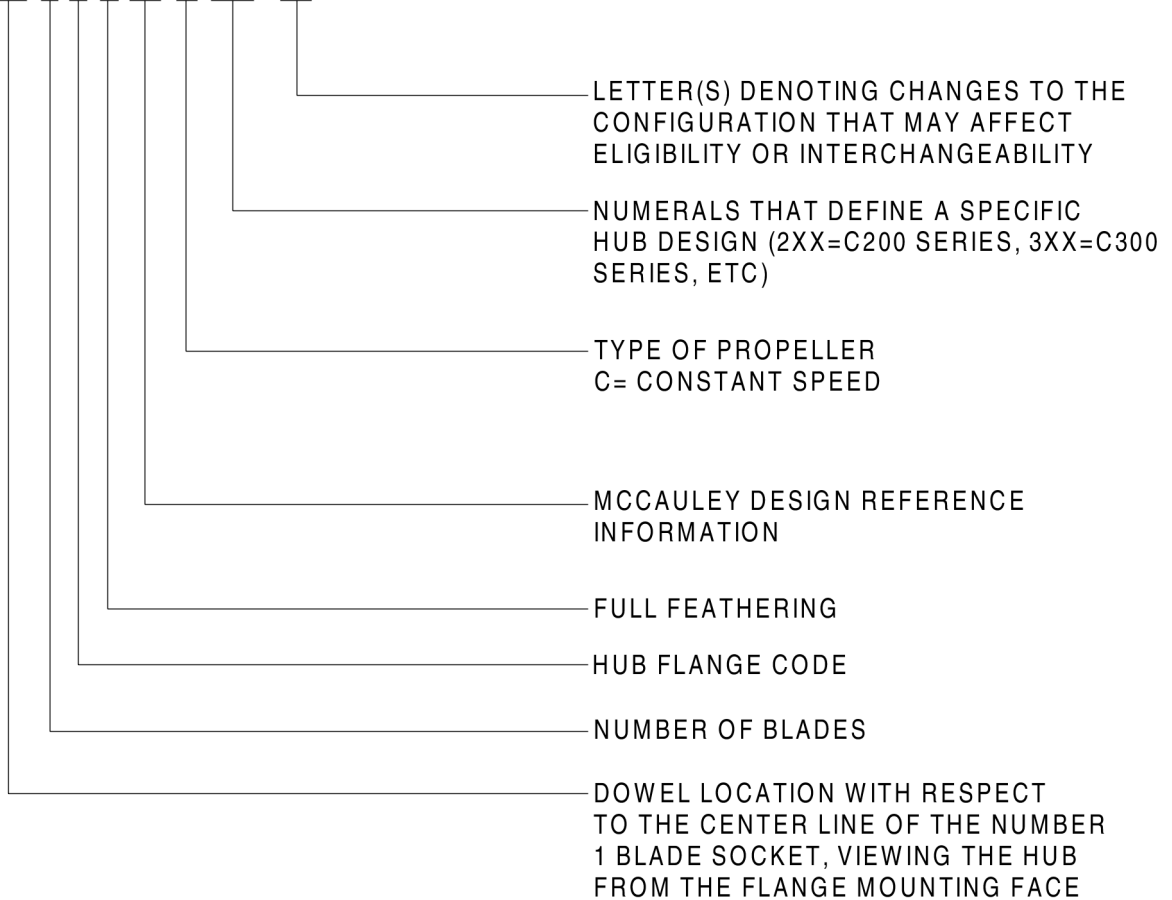

NOTE: A SPECIFIC PROPELLER ASSEMBLY IS IDENTIFIED BY THE HUB SERIAL NUMBER WHICH IS STAMPED ON THE HUB. ALL RECORDS OF PROPELLER COMPONENTS ARE KEPT WITH REFERENCE TO HUB SERIAL NUMBER. THE FIRST TWO DIGITS OF THE HUB SERIAL ARE THE YEAR OF MANUFACTURE. THE REMAINING DIGITS ARE THE NUMBER OF THE HUB MANUFACTURED IN THAT YEAR.

McCAULEY PROPELLER SYSTEMS
OWNER/OPERATOR
INFORMATION MANUAL

C1031

[X]3GFR32C618-[X]- SAMPLE TURBOPROP HUB MODEL DESIGNATION

[X] 3 G F R 32 C 618 - [X]

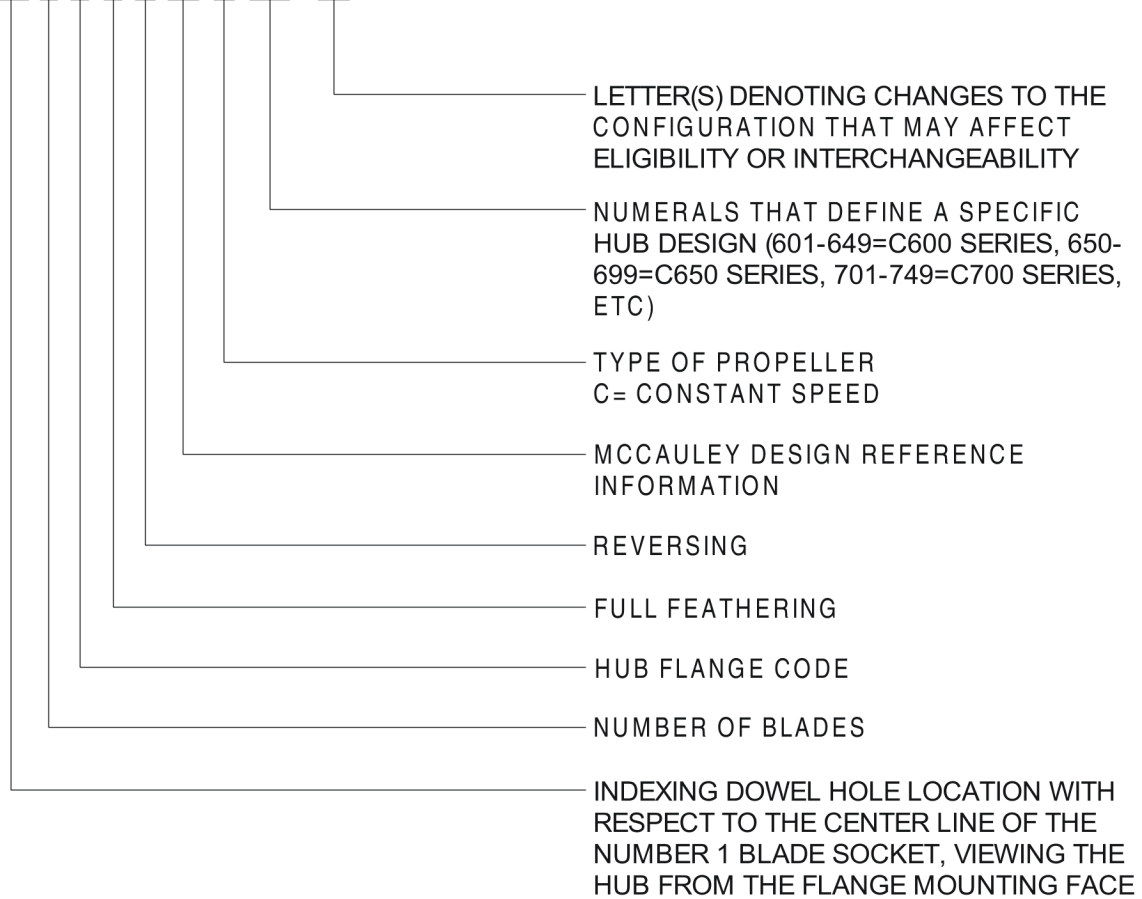

NOTE: A SPECIFIC PROPELLER ASSEMBLY IS IDENTIFIED BY THE HUB SERIAL NUMBER WHICH IS STAMPED ON THE HUB. ALL RECORDS OF PROPELLER COMPONENTS ARE KEPT WITH REFERENCE TO HUB SERIAL NUMBER. THE FIRST TWO DIGITS OF THE HUB SERIAL ARE THE YEAR OF MANUFACTURE. THE REMAINING DIGITS ARE THE NUMBER OF THE HUB MANUFACTURED IN THAT YEAR.

McCAULEY PROPELLER SYSTEMS
OWNER/OPERATOR
INFORMATION MANUAL

C. Blade Model Designation

- (1) All blades are impression stamped on the butt end with blade model designation, propeller type certificate number, and blade serial number. This stamping is not visible from the outside of the propeller assembly. The following is an example of blade model designation:

C1130

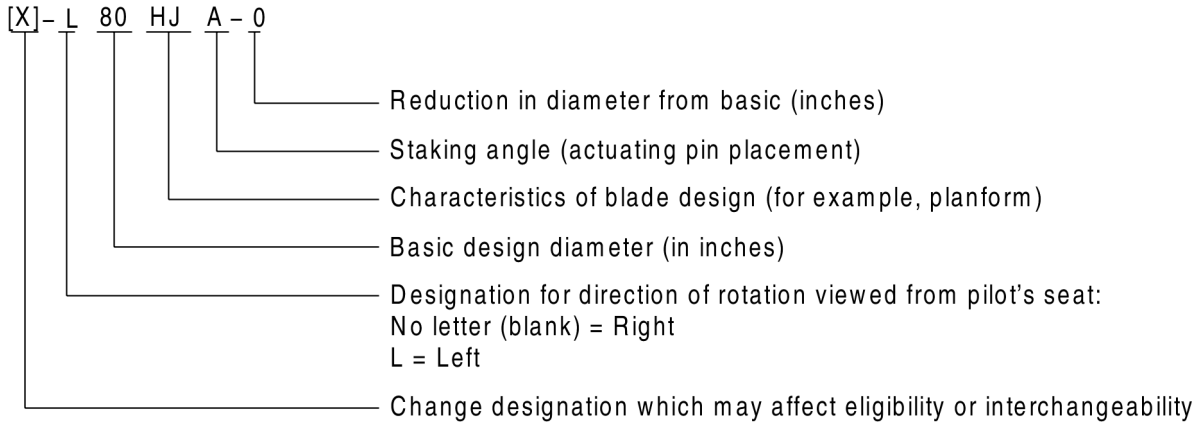

McCAULEY PROPELLER SYSTEMS
OWNER/OPERATOR
INFORMATION MANUAL

PROPELLER TROUBLESHOOTING

1. General Information

A. Types of Problems Normally Encountered

- (1) This section outlines and explains a number of operating characteristics which have been observed in service. There is some discussion of propeller design as it relates to these characteristics. Procedures for locating and correcting causes of undesirable operation are given.

2. Operation in Restricted Power or RPM Conditions (Turbine)

A. There are several risks to the propeller blades and or hubs if the propeller is operated in restricted areas.

- (1) Each propeller is subjected to rigorous vibration tests to determine that the conditions under which a particular propeller/engine/airframe combination will operate safely. Certain power settings or RPM ranges are restricted by either the airframe manufacturer and/or McCauley. This is because vibrations produced in the restricted ranges can cause fatigue cracks in the hub or blades. Such cracks could cause catastrophic failures of the propeller and a subsequent crash of the aircraft.

B. Always carefully obey the restrictions published in the aircraft AFM/POH or the POH supplement provided with the STC under which the propeller is installed.

CAUTION: Failure to follow the published limitations for any McCauley propeller, could result in a reduced life or possibly even catastrophic loss of the propeller and/or aircraft.

C. If you are aware that a McCauley propeller has been operated outside the published limitations or in a restricted area, immediately call McCauley Product Support for assistance.

3. Propeller RPM Fluctuations (Constant Speed Piston, Turbine)

A. Symptoms:

- (1) Hunting is a cyclic or constant variation of engine speed, above and below that desired. It will be shown by constant wavering of the tachometer reading.
- (2) Surging is a wide or excessive increase or decrease in engine speed followed by return to the established speed after one or more oscillations.
- (3) Surging will occur and should be considered normal if lever/throttle is moved rapidly.

B. Possible Causes:

- (1) Hunting is seldom, if ever, caused by the propeller itself. Those conditions reported primarily have been caused by other parts of the system such as governor, fuel control, etc.
 - (a) For piston engine installations, the propeller can be tested in flight by reducing the manifold pressure. The propeller control should be in the full RPM position and the manifold pressure should be reduced until the RPM drops slightly. This ensures that the propeller is against its low pitch stop and is eliminated from the equation.
- (2) Surging may be caused by air in the propeller control hydraulic system, governor not operating correctly, or problems associated with the engine transfer bearing or collar.
- (3) If the governor test is satisfactory and no other system faults can be found, the propeller may be at fault. Although very rare, hunting and surging may be due to excessive internal pressure in the propeller or overshimming of the propeller blades.

C. Corrective Action:

- (1) If the propeller is suspected as the cause, it should be removed for examination by a McCauley authorized service facility.
- (2) Surging has been encountered on ground operation after initial installation while purging air from the system.
 - (a) If encountered at other times, the propeller should be cycled repeatedly to remove all air from the system.

McCAULEY PROPELLER SYSTEMS
OWNER/OPERATOR
INFORMATION MANUAL

- (b) If the condition persists, it may be attributable to the governor, and the governor should be removed and tested. The propeller should be purged of air again after the governor is reinstalled.

4. Changing RPM or Creeping (Constant Speed Piston, Turbine)

- A. Propeller RPM changing and holding new setting.
 - (1) Possible Cause:
 - (a) Excessive "play" in the linkage between the governor and the cockpit control often leads to erratic operation.
 - (b) (Constant speed piston only) Possible excessive engine compartment heat affecting the governor plastic top cover.
 - (2) Corrective Action:
 - (a) Trace linkage, locate unsecured sections, and tighten as needed.
 - (b) Please note that although linkage may appear to allow full governor control while the engine is off, it may not in the air. Engine vibration and "stretch" of the mount during operation can often aggravate the condition. Therefore, it is important the entire length of linkage be properly secured.
 - (c) (Constant speed piston only) If heat has distorted the plastic top cover, replace it with an aluminum top cover.
- B. Once speed control and power settings are established for a flight attitude (cruise) and then the attitude is altered (to climb) without change of speed and power settings, the engine speed may change slightly.
 - (1) Possible Causes:
 - (a) This effect is commonly known as "creeping" of the speed setting. It is a natural result and comes about in the following manner. When speed and power settings are established, the governor control valve will be opened an amount to provide a pressure which balances the propeller counterweight forces and spring load, and an oil flow which is determined by the leakage through the propeller pitch control bearing at that pressure. This will maintain the blade angle such that set power may be absorbed at the desired speed.
 - (b) If the attitude of the aircraft is altered and the airspeed changes, the blade angle will change to absorb the power at this airspeed. This change in blade angle will cause the forces to vary and consequently will change the control pressure and the propeller pitch control bearing leakage rate.
 - (c) Since the governor had been adjusted by the speed control for the first set of conditions, the effect will be to change the effective equilibrium speed of the propeller with no change in governor setting. The amount of change varies with engine transfer bearing clearance.
 - (d) This speed change is generally a negligible amount and is not cause for concern since it is a normal reaction of the control system.
 - (e) Control-friction lock in the aircraft is faulty.
 - (2) Corrective Action:
 - (a) If it is desired that the original speed setting be maintained in the new flight attitude, it may be necessary to alter the propeller control lever as required after the aircraft is trimmed out.
1 Refer to the aircraft maintenance manual.

5. Improper Propeller Static RPM (Piston)

- A. Incorrect propeller speed at a given power and static RPM setting.
 - (1) Possible Cause:
 - (a) If maximum static RPM is incorrect, the problem can normally be attributed to either incorrect low blade angle or insufficient engine horsepower. However, if the maximum in-flight RPM is incorrect, then an adjustment of the governor may be necessary.

NOTE: On static runs, the propeller should prevent the engine RPM from going to red line. This is done to prevent overspeeding and is a design characteristic of the propeller. However, it should be within 100 RPM of red line.

McCAULEY PROPELLER SYSTEMS
OWNER/OPERATOR
INFORMATION MANUAL

- (2) Corrective Action:
 - (a) One area that is often at fault for indicated RPM problems is the tachometer. Aviation tachometers can be inaccurate, so begin troubleshooting by verifying the accuracy of the tachometer.
 - (b) Verify the propeller low blade angles are correct. This is most effectively accomplished at a McCauley authorized propeller repair facility. This is done by measuring the blade angle at the reference station (generally the 30 inch (762 mm) station) and comparing the angles to those listed in either the type certificate of the airframe manufacturer or the STC under which the propeller was installed. If the angles are correct, then the engine is not producing the proper horsepower needed to make the rated static RPM.
 - (c) Begin troubleshooting the engine.

6. Improper Propeller Maximum RPM in Flight (Constant Speed Piston)

- A. Incorrect propeller speed with maximum RPM selected in flight.
 - (1) Possible Cause:
 - (a) Inaccurate tachometer reading.
 - (b) Linkage is out of rig.
 - (c) Governor stop screw requires adjustment.
 - (2) Corrective Action:
 - (a) Repair or replace the tachometer.
 - (b) Governor stop screw requires adjustment.
 - 1 Do a test flight.
 - 2 Pull the propeller control back until it reaches redline RPM.
 - 3 Allow the RPM to stabilize.
 - 4 Land the aircraft without touching the propeller control lever.
 - 5 Adjust the propeller stop screw to the propeller control location.
 - 6 Rig the aircraft power controls in accordance with the instructions of the manufacturer.
 - 7 Do another flight test to verify the correct setting.

7. Propeller Fails to Control

- A. (Constant speed, non-feathering only) Propeller goes to low pitch (high RPM) of its own accord.
 - (1) Possible Cause:
 - (a) Governor linkage disconnected.
 - 1 Corrective Action:
 - a Check and repair governor linkage.
 - (b) Engine transfer bearing/collar oil leakage rate exceeds specification.
 - 1 Corrective Action:
 - a Check transfer bearing/collar oil leakage rate per the instructions of the engine manufacturer.
 - (c) Loss of engine oil pressure.
 - 1 Corrective action:
 - a Verify the engine oil pressure in accordance with the instructions of the engine manufacturer.
 - (d) Obstruction in the crankshaft.
 - 1 Correction action:
 - a Remove propeller and check for obstruction in the crankshaft oil gallery (ie. rags, shipping plugs, etc.).
 - (e) Internal governor problem.
 - 1 Corrective Action:
 - a Have the governor checked by an FAA approved Part 145 Propeller Repair Station or international equivalent.

NOTE: Failure of an internal governor part may result in metal contamination in the engine oil lubrication system. If internal governor failure is confirmed, the engine and propeller should be checked for metal contamination in accordance with the specifications of the engine manufacturer.

McCAULEY PROPELLER SYSTEMS
OWNER/OPERATOR
INFORMATION MANUAL

B. (Feathering propeller) The propeller goes to high pitch or feathers of its own accord. This may occur without warning from otherwise normal operation and may or may not be accompanied by noticeable external oil leakage.

(1) Possible Cause:

(a) Incorrectly adjusted governor.

1 Corrective Action:

a Have the governor checked by an FAA approved Part 145 Propeller Repair Station or international equivalent.

(b) Incorrectly rigged governor.

1 Corrective Action:

a Check governor control rigging in aircraft for proper operation.

(c) Engine transfer bearing/collar oil leakage rate exceeds specification.

1 Corrective Action.

a Check transfer bearing/collar oil leakage rate per the instructions of the engine manufacturer.

(d) Loss of engine oil pressure.

1 Corrective action:

a Verify the engine oil pressure in accordance with the instructions of the engine manufacturer.

(e) Obstruction in crankshaft.

1 Correction action:

a Remove propeller and check for obstruction in the crankshaft oil gallery (ie. Rags, shipping plugs, etc.).

(f) Internal governor problem.

1 Corrective Action:

a Have the governor checked by an FAA approved Part 145 Propeller Repair Station or international equivalent.

NOTE: Failure of an internal governor part may result in metal contamination in the engine oil lubrication system. If internal governor failure is confirmed, the engine and propeller should be checked for metal contamination in accordance with the specifications of the engine manufacturer.

C. Extreme sluggishness, failure to respond to changes in RPM setting or failure to hold constant RPM with varying aircraft attitude.

(1) Possible Cause:

(a) Obstruction in the engine crankshaft.

1 Correction action:

a Remove propeller and check for obstruction in the crankshaft oil gallery (ie. Rags, shipping plugs, etc.).

(b) Internal governor problem.

1 Corrective Action:

a Have the governor checked by an FAA approved Part 145 Propeller Repair Station or international equivalent.

NOTE: Failure of an internal governor part may result in metal contamination in the engine oil lubrication system. If internal governor failure is confirmed, the engine and propeller should be checked for metal contamination in accordance with the specifications of the engine manufacturer.

(c) Internal Propeller problem.

1 Corrective action:

a Have the propeller checked by an FAA approved Part 145 Propeller Repair Station or international equivalent..

McCAULEY PROPELLER SYSTEMS
OWNER/OPERATOR
INFORMATION MANUAL

- (d) Engine transfer bearing/collar oil leakage rate exceeds specification or rotated engine transfer bearing.
 - 1 Corrective Action.
 - a Check transfer bearing/collar condition and oil leakage rate per the instructions of the engine manufacturer.

8. Propeller Feathers at Shutdown (300, 500, 600, 650, and 1100 Model Series Only)

WARNING: Before starting an engine with a feathered propeller, engine manufacturer should be consulted.

CAUTION: Do not start the engine and do a run-up with the cockpit propeller control lever in the "feather" position. This results in latching mechanism failure.

- A. After engine shut down, the propeller may move slowly to the full-feathered position.
 - (1) Possible Cause:
 - (a) Damaged latch mechanisms, corrosion, dirt, or foreign matter in the mechanism causing latch weights to stick (may be evidenced by intermittent condition).
 - (b) Propeller control not set to maximum RPM at shutdown.
 - (2) Corrective Action:
 - (a) Repair of latching mechanism must be performed by an FAA approved Part 145 Propeller Repair Station or international equivalent.

9. Propeller Fails to Feather Properly

- A. Failure of the propeller to feather normally after the propeller control is moved to the feathering position.
 - (1) Possible Causes:
 - (a) Lack of feather response may be due to one of the following causes:
 - 1 Malfunction or incorrect rigging of control linkage.
 - 2 Misadjusted governor.
 - 3 High blade turning friction.
 - 4 Improperly installed deice system.
 - 5 Inoperative start lock latches.
 - (2) Corrective Action
 - (a) Check all propeller control rigging for incorrect adjustment. Replace propeller governor with known working unit. If neither of these actions eliminates the problem, the propeller may be at fault. Remove propeller for examination at an FAA approved Part 145 Propeller Repair Station or international equivalent.

10. Vibration Troubleshooting

- A. Troubleshooting vibration problems can be very challenging and time consuming. Most digital dynamic equipment can also be used to track down vibration problems. The digital dynamic balancing equipment can display the amplitude and frequency of the vibration which will help determine the vibration source. While vibration problems are occasionally caused by the propeller, they are usually caused by other things. Below is a list of other possible sources of vibration:
 - (1) Engine
 - (2) Worn, old, cracked or loose engine mounts
 - (3) Cracked or loose engine mount structure
 - (4) Cracked or broken spinner bulkheads
 - (5) Loose or improperly mounted engine cowlings
 - (6) Loose cowl flaps
 - (7) Loose landing gear doors
 - (8) Out of balance elevators
 - (9) Loose control yokes
 - (10) Exhaust stack touching engine cowling
 - (11) Component in engine compartment that is touching engine cowling

McCAULEY PROPELLER SYSTEMS
OWNER/OPERATOR
INFORMATION MANUAL

11. Unusual Aircraft Vibration

- A. Apparently excessive vibration felt during normal aircraft operation.

CAUTION: If a vibration starts suddenly and/or is accompanied by the leaking of red dyed oil from the propeller, determine the cause of the vibration and/or oil leakage before continuing propeller operation.

(1) Possible Causes:

- (a) If the propeller is believed to be the cause of the vibration, it is typically due to improper balance, blade track, or linkage problems within the propeller assembly.
- (b) When a propeller is the cause of vibration, the aircraft typically vibrates throughout the entire RPM range although the intensity of the vibration may vary with the RPM. If a vibration occurs at only one RPM or within a limited RPM range, the vibration is not normally due to a propeller problem.

(2) Corrective Action:

- (a) If the propeller is suspected as the cause of the vibration, the following procedures should be performed:

1 The ideal troubleshooting method is to temporarily replace the propeller with one that is known to be good and is the same model and test fly the aircraft. If the vibration is eliminated, the propeller is highly suspect and should be sent to an FAA approved Part 145 Propeller Repair Station or international equivalent for evaluation.

2 If a replacement propeller is unavailable, check the following.

- a Propeller imbalance can be the cause of vibration. Perform a dynamic balance on the suspect propeller to determine balance of the propeller. If the propeller cannot be successfully dynamically balanced, it should be removed and sent to an FAA approved Part 145 Propeller Repair Station or international equivalent for evaluation.
- b Check the spinner for cracks at the bulkhead attach points for a cracked bulkhead or for a cracked front support.
- c The propeller spinner can be a contributing factor to an out of balance condition. An indication of this would be a noticeable spinner "wobble" while the engine is running. This condition is normally caused by inadequate shimming of the spinner bulkhead or a cracked or deformed spinner. If a spinner is found to be "wobbling", it should be removed and reinstalled with the proper amount of shims as described in Fixed Pitch Propeller Removal and Installation, Constant Speed Reciprocating Engine Propeller Removal and Installation (Piston), C600/C650/C1100 Series Propeller Removal and Installation, or C700/C750/C1000 Propeller Removal/Installation. Any spinner found cracked must be replaced.
- d Check amount of blade twist of each propeller blade when rotated within its socket as shown in Figure 101. Look for variations in the amount of movement of each blade in relation to the other blade(s).
- e If excessive blade twist is found in one or more blades in relation to the others, the propeller could have an internal linkage problem. It should be removed and sent to an FAA approved Part 145 Propeller Repair Station or international equivalent for evaluation.

NOTE: The amount of total blade twist in each blade is, in itself, usually of no importance. It is a difference in the amount of blade twist from blade to blade that should be considered.

(3) Possible Cause:

- (a) Worn engine mounts.

(4) Corrective Action:

- (a) Consult the OEM or engine mount manufacturer manual for replacement criteria.

McCAULEY PROPELLER SYSTEMS
OWNER/OPERATOR
INFORMATION MANUAL

12. Blade Shake

A. Symptom:

NOTE: "Blade Shake" is listed in the "Propeller Troubleshooting" section of this manual for informational purposes only as it has been misinterpreted in the past as a possible problem by some operators. Despite its appearance in this section, it should never be considered a cause for concern or propeller replacement.

- (1) Blade shake is the tendency for the blades to wobble slightly when the tip is physically moved by hand from the leading edge to the trailing edge (Refer to Figure 101).
 - (a) Total maximum allowable movement up to 0.125 inch (3.13 mm) at the blade tip is considered normal.

B. Cause:

- (1) This tendency is the natural result of a tolerance buildup. A very small movement at the hub is magnified many times at the blade tip. It is NOT the source of vibration or any other problems. While the propeller is rotating, centrifugal force on the blades seats them rigidly and positively against the retention bearings in the hub.

C. Corrective Action:

- (1) No corrective action is required.

13. Oil or Grease Leaks

A. The presence of oil or grease on propeller blades may or may not indicate a problem.

- (1) Grease lubricated propellers may have grease deposits on the blade shank during the first 25 or 50 hours of operation after overhaul because the retaining bearings were packed with an excessive amount of grease.
- (2) All propeller blades may show minor grease streaking when new or newly overhauled. Such streaking is normal and is the result of lubricant applied to the blade O-ring during assembly.
- (3) Oil-filled propellers may show signs of oil deposited on the blade shank during operation after an overhaul or after a prolonged period of inactivity.

B. Checking and correcting a leaking propeller at the blade (C200 model series thru C1100 propeller model series only).

NOTE: This procedure will only correct blade shank leaks at the blade shank O-ring.

- (1) Use a clean cloth dampened with mineral spirits to clean the blade of all traces of oil and dirt.

CAUTION: Never exceed the published engine operational limits.

- (2) Run the engine and cycle the propeller at least five times.
 - (a) Piston airplanes: cycle from low to high pitch.
 - (b) Turbine airplanes: cycle from reverse to high pitch.
- (3) Check the blade for signs of continued leakage.
 - (a) If necessary, clean the blade again with a cloth dampened with mineral spirits to clean the blade of all traces of oil and dirt.
- (4) Run the engine and cycle the propeller at least five times.
 - (a) Piston airplanes: cycle from low to high pitch.
 - (b) Turbine airplanes: cycle from reverse to high pitch.
- (5) If the leak has stopped completely, no other action is required.
- (6) If the rate of leak has decreased, it is permissible to continue operation of the propeller for up to 20 hours.
 - (a) If there is leakage after 20 hours, the propeller must be removed from the aircraft and sent to an FAA approved Part 145 Propeller Repair Station or international equivalent for repair.
- (7) If the rate of leakage increases, do not operate the propeller. Immediately send the propeller to a McCauley authorized propeller service facility.

McCAULEY PROPELLER SYSTEMS
OWNER/OPERATOR
INFORMATION MANUAL

C89

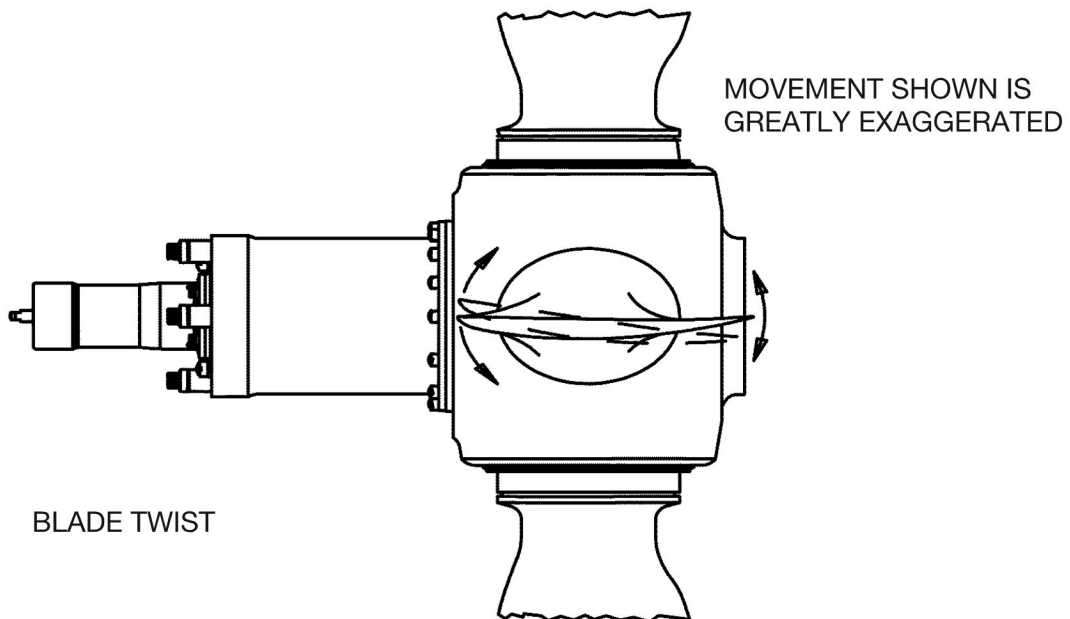
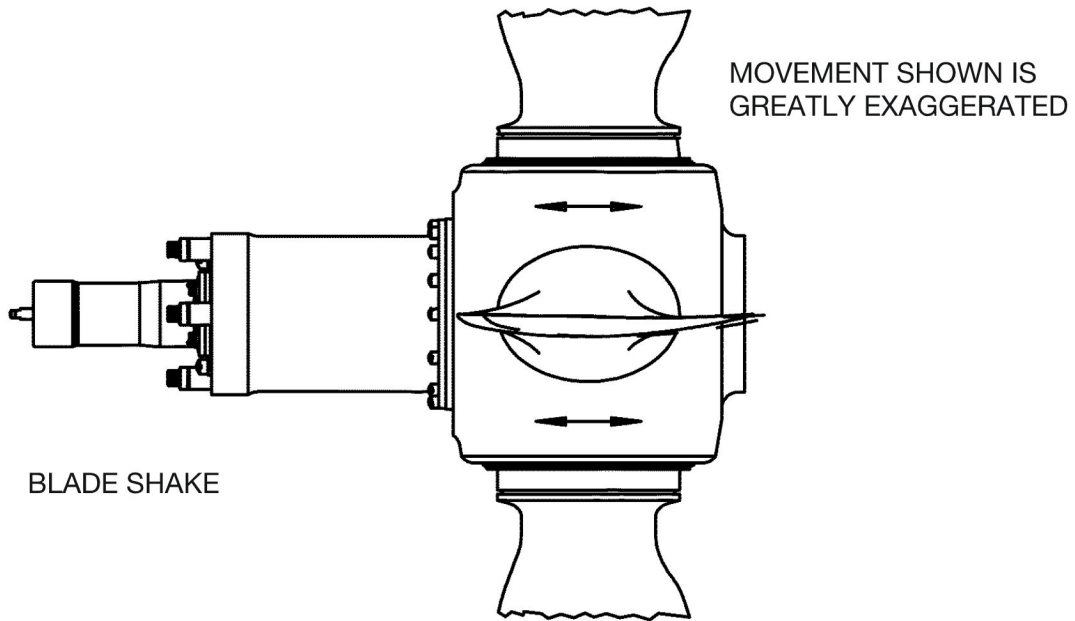

Blade Shake and Blade Twist
Figure 101 (Sheet 1)

McCAULEY PROPELLER SYSTEMS
OWNER/OPERATOR
INFORMATION MANUAL

- C. Oil leaks at locations other than blades.
 - (1) Piston aircraft propellers.
 - (a) Leakage from the cylinder area requires removal of the propeller and repair by an FAA approved Part 145 Propeller Repair Station or international equivalent.
 - (b) If leaks are found on any other spot on the blade or the hub, remove the propeller and repair by an FAA approved Part 145 Propeller Repair Station or international equivalent.
 - (c) Leaks at the hub/propeller shaft interface requires removal of the propeller and replacement of the rear hub O-ring.
 - (2) Turbine aircraft propellers
 - (a) Leakage from the cylinder or support plate area requires removal of the propeller and repair by an FAA approved Part 145 Propeller Repair Station or international equivalent.
 - (b) Leaks at the hub/propeller shaft interface requires removal of the propeller and replacement of the rear hub O-ring.
 - (c) A leak from the actuating spring area is engine oil and must be corrected immediately to prevent engine damage from lubrication oil depletion.
 - (d) If leaks are found on any other spot on the hub, remove the propeller and arrange to have the propeller repaired by an FAA approved Part 145 Propeller Repair Station or international equivalent.

14. Propeller Overspeeding

- A. During normal operation, the propeller suddenly overspeeds past rated RPM.
 - (1) Possible Causes:
 - (a) A number of factors can cause propeller overspeeding, but these are normally caused by the engine or governor.
 - (2) Corrective Action:
 - (a) Refer to Propeller Overspeed Inspection Requirements, for required action after an overspeed incident.

McCAULEY PROPELLER SYSTEMS
OWNER/OPERATOR
 INFORMATION MANUAL

PROPELLER MAINTENANCE PRACTICES

1. Ground Support Equipment

A. The following special equipment is required for field maintenance of McCauley propellers.

NAME	PART NUMBER	MANUFACTURER	USE
Propeller protractor		Commercially available	To measure blade angles on 600, 650, and 1100 Series propellers.
Torque wrench adapter	B-5588	McCauley	To torque turbine propeller mounting nuts.
Feedback collar retractor	D-5945	McCauley	To aid in removal and installation of C700, C750, and C1000 series propellers.
Start lock release tools	B-5021	McCauley	To release start locks on C600, C650, and C1100 series propellers.
Beta tube installation and adjustment tool	B-5378	McCauley	To install and adjust beta tube on C600, C650, and C1100 series propellers.

2. Procedures For Maintenance

A. Maintenance begins with the operator and includes inspection together with regular care. Many maintenance tasks that may be accomplished at a minimum cost can extend the life of the propeller and reduce or prevent costly repairs. The following is a listing of what operators of aircraft CAN and CANNOT DO.

B. Operators CAN do the following:

NOTE: The following activities are not preventive maintenance activities as defined by Title 14 of the Code of Federal Regulations, Part 43. Appendix A, Major Alterations, Major Repairs, and Preventive Maintenance.

- (1) Perform a visual preflight inspection of the blades for nicks, scratches, dents, erosion, corrosion, cracks, etc. Apparent damage found should be referred to an appropriately rated mechanic. A crack or bend is cause for the removal of the propeller.
- (2) Check the propeller spinner attaching screws for security and check the spinner for damage.
- (3) Check the propeller for evidence of oil or grease leakage.
- (4) Clean propeller blades periodically using fresh water, a non-alkaline cleaner and a soft cloth or soft brush. Dry with a soft cloth.

NOTE: Always have a blade pointing down to prevent moisture from collecting in the hub.

- (5) For propellers operating in corrosive environments, such as agricultural or costal operations:
 - (a) Clean the area of the propeller blade snap rings and the propeller hub blade sockets with water, soft bristle brush (do not use a hard bristle brush), and clean towel.
 - 1 Remove as much foreign material from the propeller blade retaining ring area as possible.
 - (b) Make sure the propeller blade retaining ring area is dry.
 - (c) Apply LPS 3® Rust Inhibitor to the retaining ring area at the base of the propeller blades and hub sockets.
 - (d) Apply LPS 3® as frequently as necessary to prevent corrosion.

McCAULEY PROPELLER SYSTEMS
OWNER/OPERATOR
INFORMATION MANUAL

- (6) Ensure that the tachometer is appropriately marked for operational limitations of the propeller and that the tachometer accuracy is checked at periodic inspection intervals.
- (7) Make sure that the applicable installation, information, and warning decals are on the propeller. These decals may include warnings against pushing or pulling on the propeller, the model number, the correct bolt torque, and dynamic balancing information.
- (8) Make sure each propeller has its own maintenance record.
- (9) The operator must arrange for the overhaul of the propeller when it reaches the McCauley recommended service time limits. Refer to Time Between Propeller Overhaul for required propeller overhaul intervals.
- (10) For safety and glare reduction for conventional single-engine tractor type aircraft, make sure the face (back) side of each propeller blade is painted flat black and the propeller tips on the camber (forward) side of each blade are painted with the appropriate colors to ensure good visibility. Make sure that any propeller paint touch up is done equally to each blade so that the balance of the propeller is not disturbed. Pusher props may have unique paint color requirements for good visibility for ground personnel. Refer to McCauley's maintenance documents.
- (11) McCauley spinners can be polished, use commercially available polishing compounds.

C. Operators CANNOT do the following:

NOTE: The following is a listing of actions that shall not be performed on or subject a McCauley propeller or component to.

- (1) Do not operate any aircraft after the propeller has been subjected to impact damage without a thorough inspection and has been approved for return to service by an appropriately rated person or repair facility.
- (2) Never straighten a damaged propeller. Even partial straightening of blades to ease shipment to a repair facility may result in hidden damage not being detected and an unairworthy propeller being returned to service.
- (3) Never repair any blade defect by welding, heating, or peening. This can induce premature blade failure.
- (4) Never chrome plate a spinner. Plating will cause cracks and spinner failure.
- (5) Do not attempt to repair or modify a propeller spinner or spinner components. Welding, riveting or bonding are not permitted on the spinner or spinner components.
- (6) Do not polish propeller blades unless specifically permitted by McCauley's instructions.
- (7) Do not fill any damaged areas of metal blades with bulk-filler materials such as epoxy or auto body fillers. This prevents areas of potential cracking from being inspected. Additionally, filling a damaged area will not correct the stress risers caused by the dent or those caused by the loading that introduced the dent.
- (8) Do not paint over areas of corrosion on blades. Corroded areas must be removed in accordance with approved procedures prior to applying the approved protective finish.
- (9) Do not run up engines in areas containing loose rocks, gravel, or debris. Avoid quartering rear winds during ground run-up because this activity can cause damaging stresses.
- (10) Do not push or pull on propeller blades when moving the aircraft by hand. Tow bars are specifically designed for this operation.
- (11) Never install a propeller on an aircraft unless it is a model approved by the aircraft type certificate data sheet (TCDS) or an appropriate supplemental type certificate (STC). The service history must be properly documented, and a pre-installation inspection must indicate that the propeller is airworthy.

3. Long Term Storage of Controllable Pitch Propellers

- A. The following is applicable to new and overhauled propellers prior to entering service (engine installation) or at any time the propeller is removed from service. Storage time is determined from date of manufacture, overhaul, or removal from aircraft.
- (1) Storage must be in a clean and dry environment, preferably in the original shipping carton and above ground level, to minimize exposure to dirt and moisture.

McCAULEY PROPELLER SYSTEMS
OWNER/OPERATOR
INFORMATION MANUAL

- (2) If the storage period exceeds three (3) years before entering service or returning to service perform the following inspection:
 - (a) For all propeller models, inspect externally for damage and corrosion. Inspection may be accomplished by an A & P mechanic or international equivalent. Make a logbook entry stating compliance with this inspection requirement. Make a reference to MPC26 and include the current revision level of this manual with the logbook entry stating compliance with this inspection requirement.
 - (b) For propellers stored with one or more propeller blades removed, inspect for internal corrosion and signs of deterioration, and repair as necessary. This must be accomplished only by an FAA approved Part 145 Propeller Repair Station or international equivalent in accordance with the appropriate propeller overhaul manual. Make a logbook entry stating compliance with this inspection requirement. Make a reference to MPC26 and include the current revision level of this manual with the logbook entry stating compliance with this inspection requirement.
- (3) For all propeller models, If storage period exceeds six (6) years, before entering service or returning to service, perform the following inspection and parts replacement:
 - (a) Disassemble as necessary to replace all rubber seals and lubricants. Total disassembly is not required unless evidence of corrosion warrants further disassembly. This must be accomplished only by an FAA approved Part 145 Propeller Repair Station or international equivalent in accordance with the appropriate propeller overhaul manual. Make a logbook entry stating compliance with this inspection requirement. Make a reference to MPC26 and include the current revision level of this manual with the logbook entry stating compliance with this inspection requirement.
 - (b) Inspect parts for damage and corrosion, repair/replace parts as necessary. Work must be accomplished only by an FAA approved Part 145 Propeller Repair Station or international equivalent in accordance with the appropriate propeller service manual. Make a logbook entry stating compliance with this inspection requirement. Make a reference to MPC26 and include the current revision level of this manual with the logbook entry stating compliance with this inspection requirement.

4. Long Term Storage of Governors and Accumulators

- A. The following is applicable to new and overhauled governors or accumulators prior to entering service (engine installation) or at any time a governor or accumulator is removed from service. Storage time is determined from the date of manufacture or overhaul or removal from aircraft.
 - (1) Storage must be in a clean and dry environment, preferably in the original shipping carton and above ground level, to minimize exposure to dirt and moisture.
 - (2) If the storage period exceeds 3 years, before entering service or returning the governor or accumulator to service, perform the following inspection:
 - (a) Inspect externally for damage and corrosion.
 - (b) Test run the governor on a governor test bench to verify correct operation and check for leakage. This must be accomplished only by an FAA approved governor repair station or international equivalent in accordance with the governor service manual.
 - (c) Pressure check the accumulator to verify correct operation and check for leakage. This must be accomplished only by an FAA approved governor repair station or international equivalent in accordance with the service manual.
 - (3) If storage period exceeds 6 years before entering service or returning to service, perform the following inspection and parts replacement:

McCAULEY PROPELLER SYSTEMS
OWNER/OPERATOR
 INFORMATION MANUAL

WARNING: COMPLETELY RELEASE ALL AIR OR NITROGEN PRESSURE BEFORE ANY DISASSEMBLY OF ACCUMULATOR. REMOVAL OF RETAINING RINGS WITH AIR PRESSURE INSIDE THE CYLINDER WILL RESULT IN EXPLOSIVE BLOW-OUT OF PARTS WITH DANGER OF SERIOUS INJURY.

- (a) Disassemble as necessary to replace *all* of the rubber seals and gaskets. Total disassembly (such as disassembling the flyweight assembly) is not required unless evidence of corrosion warrants further disassembly. This must be accomplished only by an FAA approved governor repair station or international equivalent in accordance with the governor service manual.
- (b) Inspect parts for damage and corrosion, repair/replace parts as necessary.
 - 1 Critical inspection areas for governors are I.D. of drive gear, O.D. of the pilot spool, and "toes" of flyweight. Work must be accomplished only by an FAA approved governor repair station or international equivalent in accordance with the governor service manual.
 - 2 Critical inspection area for accumulators is inside of cylinder for corrosion. Work must be accomplished only by a FAA approved governor repair station or international equivalent in accordance with the service manual.
- (4) Test run the governor on a governor test bench to verify correct operation and check for leakage. This must be accomplished only by an FAA approved governor repair station or international equivalent in accordance with the governor service manual.
- (5) Pressure check accumulator to verify correct operation and check for leakage. This must be accomplished only by an FAA approved governor repair station or international equivalent in accordance with the governor service manual.

5. Dynamic Balance

NOTE: Some aircraft manufacturers do not approve dynamic balance of the propeller because of potential crack damage to spinner bulkhead from the installed weight.

A. Recommended test equipment.

NAME	NUMBER	MANUFACTURER	USE
Balance Analyzer	Model 2020 Pro Balancer Analyzer	ACES Systems 10737 Lexington Drive Knoxville, TN 37932-3294, <u>Web:</u> <u>www.Acessystems.com</u>	For propeller dynamic balance

B. It is highly recommended that this procedure be performed following static balancing. All of the procedures and guidelines listed below should be used in conjunction with the dynamic balance equipment manufacturer's instructions.

- (1) Perform dynamic balance according to balance equipment manufacturer's instructions.
- (2) If the initial reading is over 0.8 ips, McCauley recommends the following should be checked/corrected:
 - (a) Shimming of the spinner shell.
 - (b) Propeller installation (properly torqued and installed flat against the mounting flange).

NOTE: If the shimming of the spinner shell and propeller installation are found to be acceptable but the initial reading is still over 0.8 ips, we recommend the propeller be taken to an FAA approved Part 145 Propeller Repair Station or international equivalent for inspection.

- (3) If the initial reading is under 0.8 ips, continue the dynamic balance in accordance with the balance equipment manufacturer's instructions.

McCAULEY PROPELLER SYSTEMS
OWNER/OPERATOR
INFORMATION MANUAL

CAUTION: At no time are static balance weights to be moved to adjust dynamic balance.

- (4) If the test indicates the addition of weights, temporarily place the indicated mass of balance washers in place of the spinner mounting screw at the location indicated by the testing equipment.
 - (a) An AN970-3 washer weight = 0.144 ounces each (4.1 grams) plus screw (AN502-10-X)
- (5) Repeat the dynamic balance until the correct balance level (approximately 0.07 ips or lower) is achieved.

NOTE: Most dynamic balance equipment manufacturers specify 0.15 - 0.2 ips as being an acceptable level. McCauley Propeller Systems agrees that 0.15 - 0.2 is an acceptable level, but our experience has shown that 0.07 ips or lower is noticeably smoother.

- (6) When dynamic balance is satisfactory:
 - (a) Remove balance washers and screw from the spinner attach screw hole.
 - (b) Permanently mount the balance washers and screws to the spinner bulkhead assembly at a point adjacent to the test location as shown on Figure 203.
- (7) Always place at least one balance weight under screw head for stress relief (see Figure 203). Return original spinner screw to hole.

WARNING: Use extreme care when you drill bulkheads near blades to avoid shank damage. Blade shank damage could potentially require propeller disassembly and blade replacement depending on the severity of the damage.

6. Spinner Repair and Chrome Plating

- A. No repair is permitted on any McCauley spinner, spinner front support, or spinner bulkhead. Follow these guidelines to determine if a part is airworthy:
 - (1) If the part has scratches and minor dents, the part can continue to be used.
 - (2) If the part is cracked, the part must be replaced.
 - (3) The welding of any McCauley spinner part or assembly is not allowed, any spinner part that has been welded shall be removed from service and scrapped.
- B. McCauley does not approve and prohibits the chrome plating of McCauley propeller spinners. Field experience has shown that chrome plated spinners often peel after a short time in service. Strong evidence also exists that chrome plating can lead to spinner fatigue cracking, thus scrapping the spinner shell. Chrome plating will void the McCauley warranty.

7. Propeller Internal Lubrication

- A. Servicing of Propeller Internal Lubrication
 - (1) General
 - (a) Unless significant oil leakage is observed, periodic servicing of the oil in McCauley oil filled propellers is not necessary.

McCAULEY PROPELLER SYSTEMS
OWNER/OPERATOR
INFORMATION MANUAL

C670

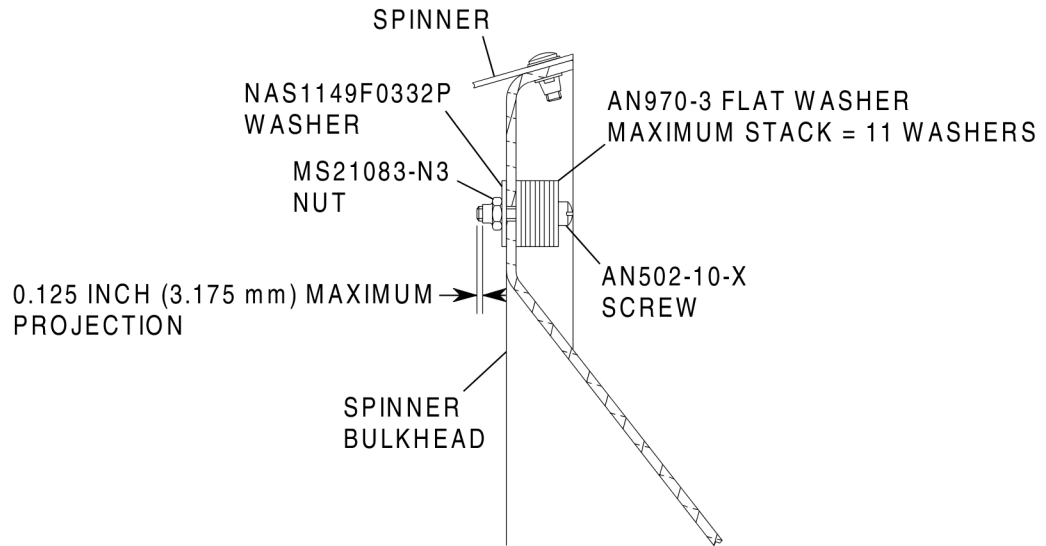
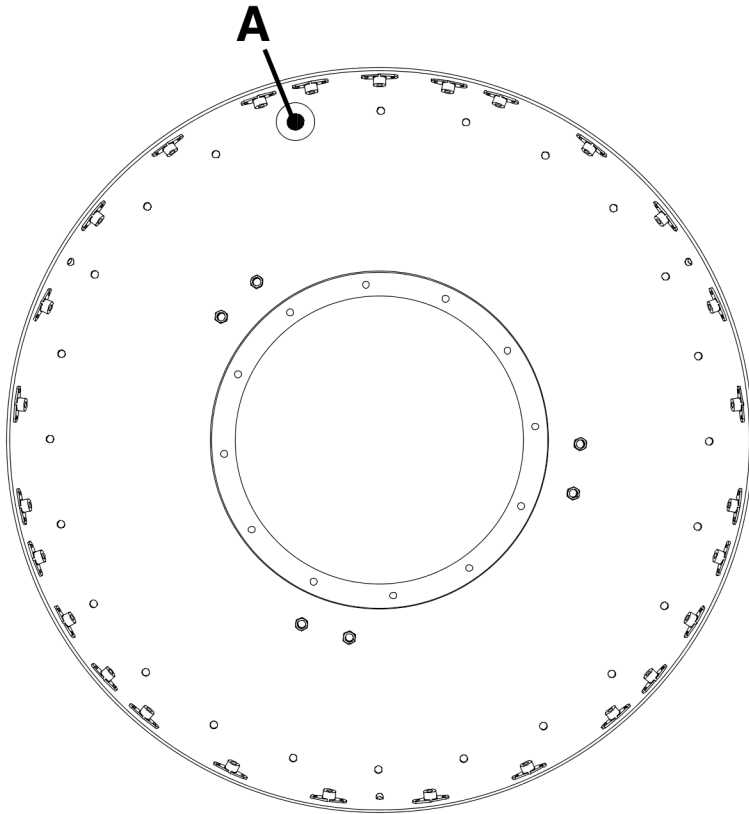

DETAIL A

0104T1004
AE-7735

Balance Weight Installation
Figure 201 (Sheet 1)

McCAULEY PROPELLER SYSTEMS
OWNER/OPERATOR
INFORMATION MANUAL

PROPELLER REMOVAL/INSTALLATION

1. Ground Support Equipment

A. The following special equipment is required for field maintenance of McCauley propellers.

NAME	PART NUMBER	MANUFACTURER	USE
Spacer Removal Tool	A-8029	McCauley	To separate and remove the propeller spacer from the propeller hub for 1A162 model propellers only.
Torque wrench adapter	B-5588	McCauley	To torque turbine propeller mounting nuts.
Feedback collar retractor	D-5945	McCauley	To aid in removal and installation of C700, C750, and C1000 series propellers.
Beta tube installation and adjustment tool	B-5378	McCauley	To install and adjust beta tube on C600, C650, and C1100 series propellers.
Start Lock Release	B-5021/2	McCauley	To release the start locks on 600, 650, and 1100 series propellers

2. Uncrating and Acceptance Checking a New Propeller

A. Uncrating the propeller.

- (1) Place the crated propeller in an area that has good lighting and where there is sufficient room to remove the crating and packaging material with the propeller laying flat against the floor or table top of sufficient size to support the propeller (with the propeller mounting flange facing down).
- (2) Inspect the exterior of the crated propeller for signs of damage. If there are any signs of damage, make sure the propeller is thoroughly inspected in the area of the observed crate damage after it has been removed from the packaging material.
- (3) Remove the crate and packaging material.

NOTE: McCauley uses a variety of shipping containers and materials. For two and three blade propellers, the crating material is almost always corrugated cardboard, with the box in the shape of a rectangle or a "Y". Four and five blade propellers are shipped in a square box usually made of wood.

- (4) After the propeller is free of the crate and packaging material, place the propeller on a propeller stand of sufficient size to safely hold the propeller.

CAUTION: Never store or stand a propeller on a propeller blade tip. Damage to the propeller may occur if it is not properly handled after it has been removed from the shipping container.

- (5) Do a visual inspection of the propeller blades and hub for surface damage such as dents, nicks, scratches, and corrosion. Sight down the edges of each propeller blade to make sure there is no deformation.

NOTE: It is possible for a propeller to sustain shipping damage while crated and for the shipping container to not sustain substantial damage as a result of the shipping damage.

McCAULEY PROPELLER SYSTEMS
OWNER/OPERATOR
INFORMATION MANUAL

- (6) Retain the installation parts that are shipped with the propeller for use when the propeller is to be installed.

NOTE: If the propeller has been shipped with one or more of the propeller blades removed from the hub, the propeller must be reassembled by an FAA approved Part 145 Propeller Repair Station or international equivalent.

3. Fixed Pitch Propeller Removal and Installation

A. General

- (1) Propeller removal and installation shall be performed only by qualified maintenance personnel. The following instructions are general in nature. The aircraft maintenance manual or STC installation instructions should always be consulted for any specialized procedures applicable to a specific aircraft. Various spinner arrangements not manufactured by McCauley may be used which require additional procedures.

NOTE: Qualified maintenance personnel means the person doing the maintenance activity is the holder of, or is working under the direct supervision of, the holder of the appropriate rating to approve the propeller for return to service after the maintenance activity has been accomplished.

- (2) In the following instructions, installation of propeller is based on the assumption that a McCauley spinner will be used. If a spinner is not used or if the spinner is not manufactured by McCauley, omit those steps which apply to the spinner.

WARNING: Verify that engine magnetos have been grounded prior to approaching the propeller.

B. Spinner Assembly Removal

- (1) Make an alignment mark on the spinner shell, aft bulkhead and adjacent blade with a felt tip pen. This index mark ensures accurate restoration of spinner shell position to lessen the distortion of any dynamic balance previously performed on the propeller assembly.
- (2) Remove screws and washers from the spinner and fillet assemblies (if fillet assemblies are installed).
- (3) Remove spinner from the bulkhead and fillet assemblies (if fillet assemblies are installed).
- (4) If required, remove screws and washers attaching fillets to bulkhead and remove fillets. Identify location of each fillet to the bulkhead.

NOTE: On some spinner assemblies, the fillets are riveted in place and cannot be removed from the bulkhead assembly.

C. Propeller Removal

- (1) Remove cowling as required for access to mounting nuts.

NOTE: Not all propellers use nuts to secure the propeller mounting bolts.

- (2) Remove the safety wire from the bolts if installed.
- (3) Break the torque on the propeller mounting bolts and nuts.
- (4) Support the propeller, remove the mounting bolts and remove the propeller from the engine crankshaft flange.

NOTE: Some propeller spinner front supports use the propeller mounting bolts to hold the front spinner support in position on the propeller.

NOTE: If you have not removed or installed the propeller and spinner assembly from the engine before, the use of a propeller sling and hoist is recommended to prevent accidental damage to the propeller. If a hoist is not available, the propeller may be supported and lifted by hand. Make sure an adequate number of people are available to support the propeller if a hoist is not used.

McCAULEY PROPELLER SYSTEMS
OWNER/OPERATOR
INFORMATION MANUAL

(5) Place the propeller on a suitable work surface.

D. Spacer Removal (If Installed).

(1) For all fixed pitch propellers (except 1A162 model propellers) with a spacer installed, (Refer to Figure 401).

NOTE: The following procedure should be used to remove a rear spinner bulkhead, when it is clamped between a spacer and the propeller hub.

- (a) Support the propeller by nesting it between two shot or sand-filled bags.
- (b) Put the supports as close to the hub as possible with the spacer down facing the bench or table top.
- (c) Make sure you allow sufficient clearance (approximately 2 inches) for the spacer to separate from the hub.
- (d) Select a punch with the proper diameter, approximately 6 inches long, and insert it into the dowel pin hole.
- (e) Alternately tap one dowel and then the other with light hammer blows to free the spacer from the propeller hub.

(2) For 1A162 model propellers with a spacer installed, (Refer to Figure 402).

(a) Tool Fabrication

NOTE: The spacer removal tool can be fabricated locally or a tool, part number A-8029, can be purchased from McCauley.

1 Use a steel bar that is at least 0.250 inch (6.35 mm) thick and 2.00 inches (51.00 mm) wide and 6.0 inches (152.0 mm) long.

2 Drill two 0.250 inch (6.35 mm) holes in the steel bar that are 2.875 inches apart, +0.020 or -0.020 inches (73.03 mm, +0.5 mm or -0.5 mm) and 1.438 inches, +0.020 or -0.020 inches (36.53 mm, +0.5 mm or -0.5 mm) from the center of the steel bar.

(b) Remove the propeller and spacer assembly from the airplane.

(c) Spacer Removal Procedure (Refer to Figure 402).

1 Attach the spacer removal tool to the propeller spacer using two 0.250 inch diameter bolts with UNC-3A threads.

NOTE: Bolts to be used should be made of steel, 0.250 inch in diameter, have a UNC-3A thread and the grip length sized to match the thickness of the steel bar. For steel bars that are 0.250 inch (6.35 mm) thick, a MS20074-04-06 bolt is an appropriate sized bolt for this application.

2 Position the propeller and spacer assembly under an arbor press or similar tool as shown in Figure 402.

3 Place two propeller mounting bolts or equivalent sized steel dowels in the propeller and spacer assembly. The bolts or dowels that are used to push the spacer from the propeller must be of equal length.

CAUTION: Do not use bolts that will be returned to service for this procedure. This procedure can damage the threads of propeller mounting bolts.

4 Make sure there is at least 2.00 inches (50 mm) clearance between the spacer removal tool attached to the propeller spacer and the work surface supporting the sandbags.

5 Using an arbor press or similar tool, push the bolts or dowels down to remove the spacer from the propeller.

6 Once the spacer is separated from the propeller, remove the 0.250 inch bolts and the spacer removal tool from the spacer.

E. Propeller Installation for all fixed pitch propellers (except 1A162 model propellers).

McCAULEY PROPELLER SYSTEMS
OWNER/OPERATOR
INFORMATION MANUAL

C871

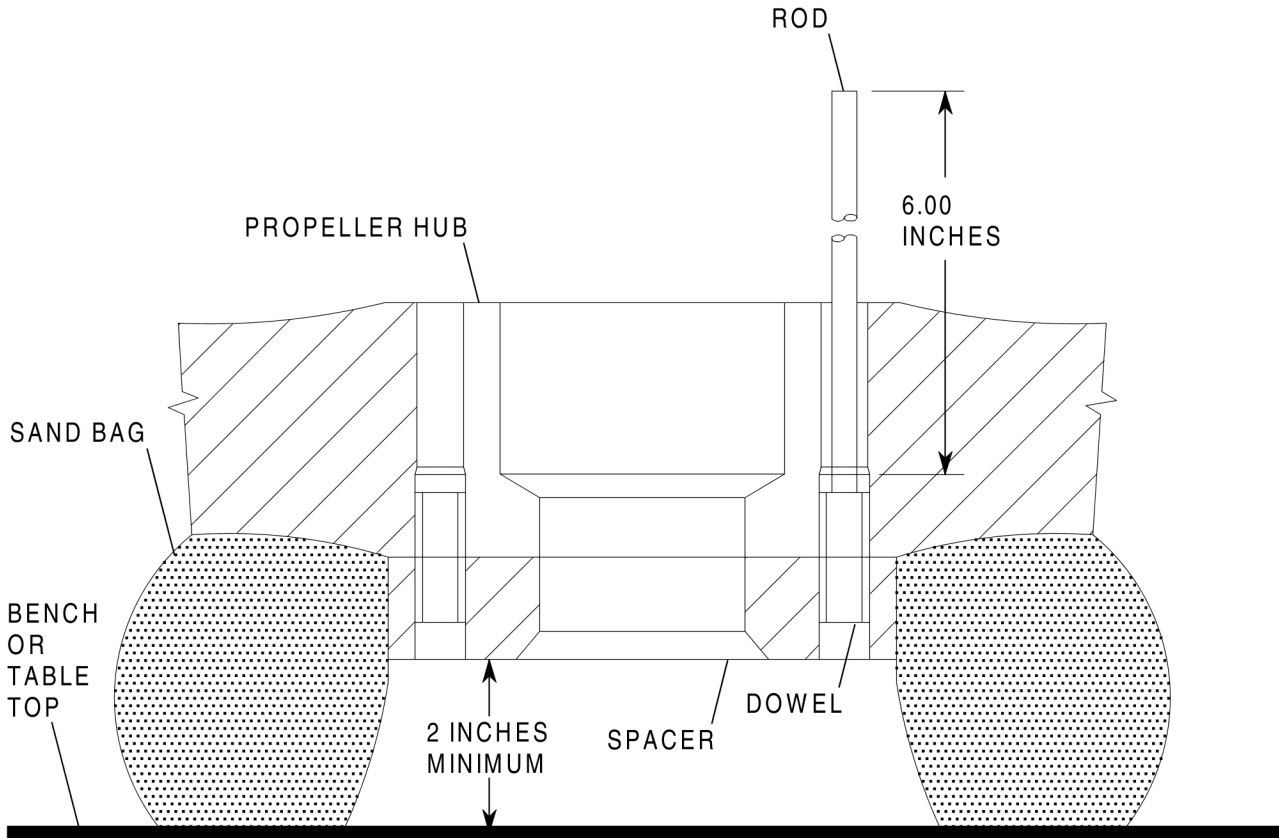

0101T1106

Remove Spacer From Propeller
Figure 401 (Sheet 1)

McCAULEY PROPELLER SYSTEMS
OWNER/OPERATOR
INFORMATION MANUAL

C1912

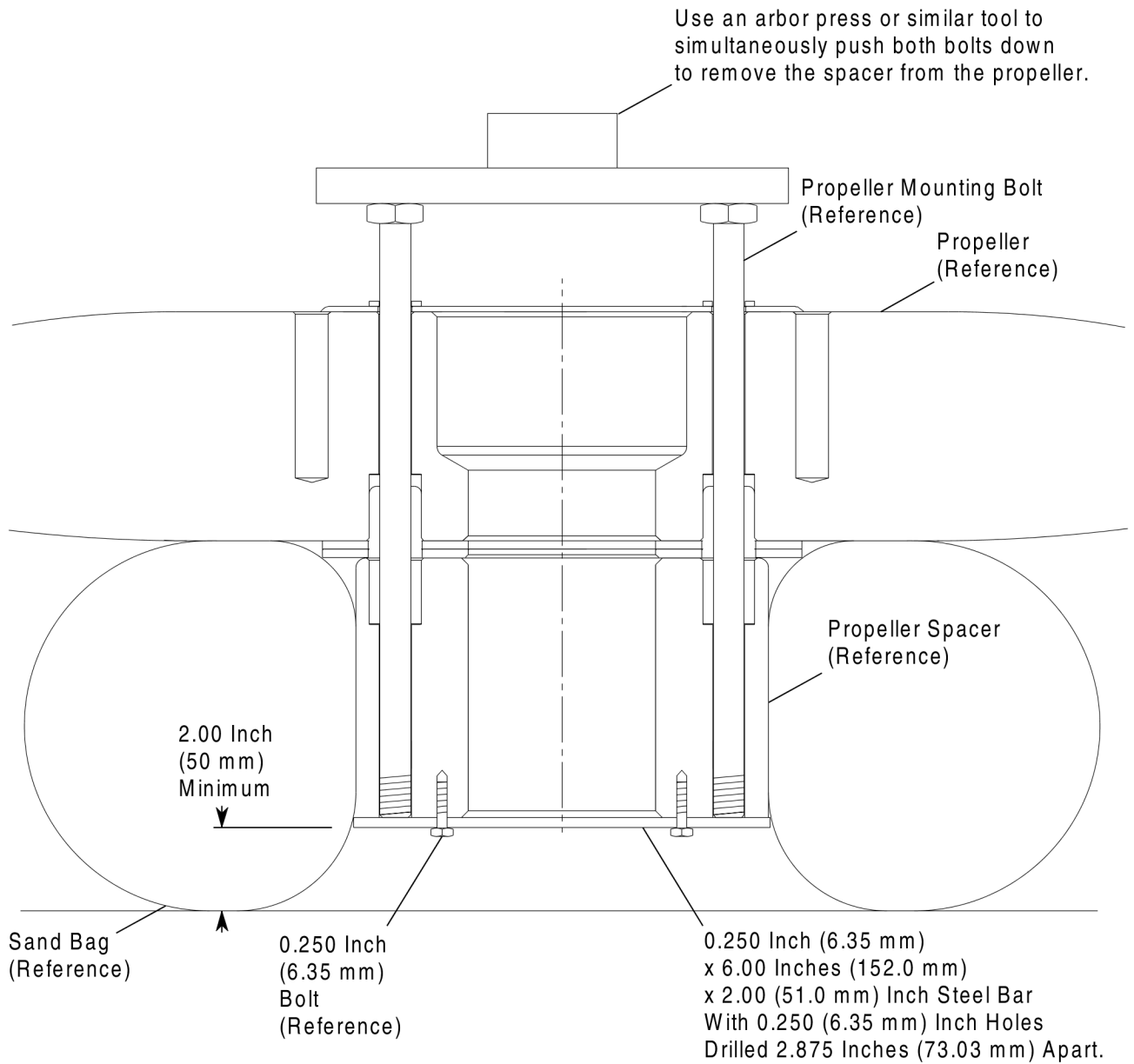

B-7925D

Remove Spacer From Propeller (1A162 Only)
Figure 402 (Sheet 1)

McCAULEY PROPELLER SYSTEMS
OWNER/OPERATOR
INFORMATION MANUAL

WARNING: MAKE SURE THE MAGNETO IS GROUNDED BEFORE INSTALLING THE PROPELLER OR CONNECTING EXTERNAL POWER.

NOTE: McCauley recommends that propeller mounting nuts (if applicable) be replaced at each propeller installation, whenever possible. However, nuts may be reused providing the threads are in good condition and the locking material prevents turning of the nut on the stud by hand. Propeller mounting bolts must be magnetic particle inspected in accordance with ASTM E-1444 or replaced whenever the propeller is removed from the engine.

NOTE: The aircraft maintenance manual or STC installation instructions should always be consulted for any specialized procedures applicable to a specific aircraft. Various spinner arrangements not manufactured by McCauley may be used which require additional procedures.

- (1) Make sure the mating surfaces of the propeller, crankshaft flange, spinner bulkheads, and spacer, if installed, are clean.
- (2) For propeller installations that use a spacer between the propeller and the crankshaft flange and the spacer has been removed from the propeller, do the following:
 - (a) Make sure the serial number stamped on the spacer is the same as the serial number stamped on the propeller.
 - (b) Make sure the alignment dowels are secure in the spacer.

NOTE: If a matched serial number pair of propeller and spacer is not available or if a dowel is loose, the propeller assembly must be taken to an FAA approved Part 145 Propeller Repair Station or international equivalent. If the serial numbers do not match, then the static balance of the propeller is unknown and should not be installed. If a dowel is loose, the dowel will need to be replaced.

- (3) Install the spacer and, if applicable, the aft spinner bulkhead on the propeller.
 - (a) Locate propeller hub on a padded arbor press table, spacer-mating surface face up.
 - (b) Make sure the serial number on the spacer aligns with the number 1 propeller blade.

NOTE: If the number 1 propeller blade cannot be identified, align the spacer serial number to the propeller blade with the propeller serial number.

- (c) Position the spinner bulkhead, if applicable, on the dowel pins between the propeller and spacer.

NOTE: The spinner aft bulkhead must be positioned so that the propeller blades emerge from the bulkhead and spinner with ample clearance. Make sure the felt tip marker line on the spinner aft bulkhead aligns with the mark on the propeller blade.

- (d) Apply a film of oil on the dowel pins.
- (e) Press the propeller and spacer together with the arbor press. Make sure you do not scratch, dent or deform the propeller or spacer during this assembly operation.
- (4) The assembled propeller, dowel and spacer should be a press fit and not separate easily.

NOTE: When the dowels are in position, the dowels will be engaged approximately half in the spacer or crankshaft flange and half in the propeller hub.

- (5) Assembly of the spinner installation is completed as the propeller is installed on the engine crankshaft flange. Some installations have the spinner aft bulkhead held between the propeller hub and the spacer. Other installations may have the front bulkhead clamped by the mounting

McCAULEY PROPELLER SYSTEMS
OWNER/OPERATOR
 INFORMATION MANUAL

bolts or nuts and the rear bulkhead clamped between the propeller and the crankshaft flange or starter ring gear. Some installations use a spacer support pressed into the front propeller hub bore.

NOTE: The aircraft maintenance manual or STC installation instructions should always be consulted for any specialized procedures applicable to a specific aircraft. Various spinner arrangements not manufactured by McCauley may be used which require additional procedures.

NOTE: If you have not installed the propeller and spinner assembly on the engine before, the use of a propeller sling and hoist is recommended to prevent accidental damage to the propeller. If a hoist is not available, the propeller may be supported and lifted by hand. Make sure an adequate number of people are available to support the propeller if a hoist is not used.

- (6) Tighten the propeller mounting bolts with the correct torque. The mounting bolt torque for McCauley fixed pitch propellers is determined by the bolt diameter. Refer to the following table to determine the correct torque for the propeller mounting bolts.

Bolt or Nut Diameter (Inch)	Torque (Dry)		
	Foot Pounds	Inch Pounds	N-m
3/8	25 to 30	300 to 360	33.895 to 40.675
7/16	40 to 45	480 to 540	54.233 to 61.012
1/2	55 to 65	660 to 780	74.570 to 88.128

- (a) If an adaptor or extension is attached to torque wrench drive end and this adds to the length of the wrench, then the actual applied torque will be greater than the torque indicated by the wrench reading. The following formula should be used to determine what the torque wrench indicator should read in order to obtain the correct applied torque:

$$\frac{(\text{actual torque required}) \times (\text{torque wrench length})}{(\text{torque wrench length}) + (\text{length of the adapter})} = \text{Torque Wrench Reading to Achieve the Required Actual Torque}$$

- (7) Torque the mounting bolts/nuts in an alternating sequence to prevent the propeller from rocking on the engine flange.
- (8) For propeller mounting bolts with drilled heads, install lockwire (use a minimum diameter of 0.032 corrosion resistant steel conforming to MS20995C32) between pairs of bolt heads.
- (9) When shims are required for location of spinner support, select quantity and thickness so that spinner shell screw holes are misaligned with the rear bulkhead holes or nuts by 1/2 hole diameter. Use at least one mylar shim to contact bolt heads.
- (10) When the correct number of shims has been determined, press or lightly tap support into hub bore, apply force to spinner shell toward propeller to align screw holes with bulkhead holes or nuts and install washers and screws.

NOTE: Make sure the felt tip marker line on the spinner aligns with the marker line on the aft spinner bulkhead and with the marker line on the propeller blade.

F. Propeller Assembly Installation for model 1A162 propellers.

McCAULEY PROPELLER SYSTEMS
OWNER/OPERATOR
INFORMATION MANUAL

WARNING: MAKE SURE THE MAGNETO IS GROUNDED BEFORE INSTALLING THE PROPELLER OR CONNECTING EXTERNAL POWER.

NOTE: McCauley recommends that propeller mounting nuts (if applicable) be replaced at each propeller installation, whenever possible. However, nuts may be reused providing threads are in good condition and the locking material prevents turning of the nut on the stud by hand. Propeller mounting bolts must be magnetic particle inspected in accordance with ASTM E-1444 or replaced whenever the propeller is removed from the engine.

NOTE: The aircraft maintenance manual or STC installation instructions should always be consulted for any specialized procedures applicable to a specific aircraft. Various spinner arrangements not manufactured by McCauley may be used which require additional procedures.

- (1) Make sure the mating surfaces of the propeller, crankshaft flange, and spinner bulkheads are clean.
- (2) For propeller installations that use a spacer between the propeller and the crankshaft flange and the spacer has been removed from the propeller, do the following:
 - (a) Make sure the serial number stamped on the spacer is the same as the serial number stamped on the propeller.
 - (b) Make sure the alignment dowels are secure in the spacer.

NOTE: If a matched serial number pair of propeller and spacer is not available or if a dowel is loose, the propeller assembly must be taken to an FAA approved Part 145 Propeller Repair Station or international equivalent. If the serial numbers do not match, then the static balance of the propeller is unknown and should not be installed. If a dowel is loose, the dowel will need to be replaced.

- (3) Install the spacer and, if applicable, the aft spinner bulkhead on the propeller.
 - (a) Locate propeller hub on a padded arbor press table, spacer-mating surface face up.
 - (b) Make sure the serial number on the spacer aligns with the number 1 propeller blade.

NOTE: If the number 1 propeller blade cannot be identified, align the spacer serial number to the propeller blade with the propeller serial number.

- (c) Position the spinner bulkhead, if applicable, on the dowel pins between the propeller and spacer.

NOTE: The spinner aft bulkhead must be positioned so that the propeller blades emerge from the bulkhead and spinner with ample clearance. Make sure the felt tip marker line on the spinner aft bulkhead aligns with the mark on the propeller blade.

- (d) Apply a film of oil on the dowel pins.
- (e) Press the propeller and spacer together with the arbor press. Make sure you do not scratch, dent or deform the propeller or spacer during this assembly operation.
- (4) The assembled propeller, dowel and spacer should be a press fit and not separate easily.

NOTE: When the dowels are in position, the dowels will be engaged approximately half in the spacer or crankshaft flange and half in the propeller hub.

- (5) Rotate the engine crankshaft so the number 1 cylinder is Top Dead Center (TDC) on its compression stroke.

McCAULEY PROPELLER SYSTEMS
OWNER/OPERATOR
 INFORMATION MANUAL

- (6) Position the propeller on the engine crankshaft so the number 1 blade is clocked 60 degrees in the direction of engine rotation from TDC.

NOTE: The number 1 blade will be located at approximately the 10 O'clock position when viewed from in front of the engine looking aft.

NOTE: If you have not installed the propeller and spinner assembly on the engine before, the use of a propeller sling and hoist is recommended to prevent accidental damage to the propeller. If a hoist is not available, the propeller may be supported and lifted by hand. Make sure an adequate number of people are available to support the propeller if a hoist is not used.

- (7) Install propeller on crankshaft flange.

WARNING: Make sure there is no lubricant on the threads of the propeller attach nuts and bolts. If the propeller attach bolts and nuts have lubricant on the threads, the bolts will be over torqued and the propeller could fail.

- (8) Install forward spinner bulkhead, washers, bolts and nuts.
 (9) Tighten bolts and torque evenly in accordance with the following table:

Bolt or Nut Diameter	Torque (DRY) Pound-Feet	Torque (DRY) Pound-Inches	Torque (DRY) Newton Meters (N-m)
3/8	25 to 30	300 to 360	33.895 to 40.675

- (10) If an adaptor or extension is attached to torque wrench drive end and this adds to its length, then the actual applied torque will be greater than the dial reading. The following formula should be used to find what the dial should read in order to obtain the correct applied torque:

$$\frac{(\text{actual torque required}) \times (\text{torque wrench length})}{(\text{torque wrench length}) + (\text{length of the adapter})} = \text{Torque Wrench Reading to Achieve the Required Actual Torque}$$

- (11) Torque the mounting bolts/nuts in an alternating sequence to prevent the propeller from rocking on the engine flange.
 (12) Safety wire propeller mounting bolts. Install the safety wire around the bolt heads. Do not install the safety wire over the top of the bolt head.
 (13) Spinner Installation (if applicable)
 (a) Put the spinner shell onto the bulkhead with the alignment marks matched.
 (b) Press firmly aft on the spinner.
 (c) Push on the spinner shell and use an awl or a small punch in an adjacent hole to move the spinner shell screw hole into alignment with bulkhead hole and install washer and screw. Repeat this procedure on opposing holes until eight evenly spaced screws and washers are installed.
 (d) Secure propeller spinner to the bulkhead with remaining screws and washers.

McCAULEY PROPELLER SYSTEMS
OWNER/OPERATOR
 INFORMATION MANUAL

4. Constant Speed Reciprocating Engine Propeller Removal and Installation (Piston)

A. General

- (1) Propeller removal and installation shall be performed only by qualified maintenance personnel. The following instructions are general in nature. The aircraft maintenance manual or STC installation instructions should always be consulted for any specialized procedures applicable to a specific aircraft. Various spinner and deice arrangements not manufactured by McCauley may be used which require additional procedures.

NOTE: Qualified maintenance personnel means the person doing the maintenance activity is the holder of, or is working under the direct supervision of, the holder of the appropriate rating to approve the propeller for return to service after the maintenance activity has been accomplished.

- (2) In the following instructions, installation of propeller is based on the assumption that a McCauley spinner will be used. If a spinner is not used or if the spinner is not manufactured by McCauley, omit those steps which apply to the spinner.
 (a) Propeller Installation Decals

Table 401. Propeller Installation Decals Torque Values

Decal Part Number	Used On	Lubricated Torque	Torque Pound-Feet	Torque Newton Meters (N-m)
A-2230	All Lycoming engine installations except installations that use the model 3AF32C524 propeller.	No	55 to 65	74.570 to 88.128
A-2230-7	Continental engine installations that use the model 3FF32C501 propeller.	Yes	68 to 72	92.196 to 97.619
A-2230-7	All Orenda engine installations.	Yes	68 to 72	92.196 to 97.619
A-2230-9	All Continental engine installations except installations that use the model 3FF32C501 propeller.	Yes	45 to 50	61.012 to 67.791
A-2230-9	All Franklin engine installations.	Yes	45 to 50	61.012 to 67.791
A-2230-9	Lycoming engine installations with a model 3AF32C524 propeller.	Yes	45 to 50	61.012 to 67.791

WARNING: Verify that engine magnetos have been grounded prior to approaching the propeller.

B. Spinner Assembly Removal

McCAULEY PROPELLER SYSTEMS
OWNER/OPERATOR
INFORMATION MANUAL

CAUTION: Make sure you do not damage or scratch the blades when removing the spinner shell.

- (1) Make an alignment mark on the spinner shell, spinner aft bulkhead and adjacent blade with a felt tip pen. This index mark ensures accurate restoration of spinner shell position to lessen the distortion of any dynamic balance previously performed on the propeller assembly.
- (2) Remove screws and washers from the spinner and fillet assemblies.
- (3) Remove spinner from the bulkhead and fillet assemblies.
- (4) Remove the spinner support and shims from the front of the propeller cylinder.
- (5) If required, remove screws and washers attaching fillets to bulkhead and remove fillets. Identify location of each fillet to the bulkhead.

NOTE: On some spinner assemblies, the fillets are riveted in place and cannot be removed from the bulkhead assembly.

C. Propeller Assembly Removal

- (1) Remove cowling as required for access to mounting nuts.
- (2) If required, remove the deice leads.
- (3) Place a drip pan under the propeller mounting surface to catch any spilled engine oil when the propeller is removed.
- (4) Break the torque on the propeller mounting nuts on Continental engine installations. For Lycoming installations, remove safety wire from the stud and nut assembly and break the torque.
- (5) Install the propeller sling and attach to a hoist. If a hoist is not available, the propeller may be supported and lifted by hand.

NOTE: Make sure an adequate number of people are available to adequately support the propeller if a hoist is not used.

- (a) The straps of the propeller sling should be placed on two of the propeller blades at least 6 inches (152 mm) outboard of the propeller hub for three blade propellers and 12 inches (305 mm) outboard of the propeller hub for two bladed propellers. Make sure you protect the deice boots or anti-ice shoes from potential propeller sling abrasion damage, if installed.
- (b) The sling and hoist should have a weight limit rating at least twice the weight of the propeller that is to be removed.
- (6) Take up slack on the propeller sling and hoist, or support the propeller by hand, and remove the nuts or bolts.

CAUTION: Propeller must be removed from engine in a straight motion. Any rocking on the engine could cause damage to the propeller mounting flange. For Lycoming propeller installations, care must be taken to remove the propeller in a straight forward motion as the propeller stud and nut assembly are loosened from the engine crankshaft flange.

- (7) Carefully slide the propeller forward and remove from the engine.
- (8) Place the propeller on a suitable support or propeller stand.
 - (a) Do not let the propeller be supported by the tips of the propeller blades or "stand" the propeller on the propeller blade tips.
 - (b) The stand should be able to hold the propeller securely and have a weight limit rating at least twice that of the removed propeller.
 - (c) Make sure the propeller is protected from damaged while in the stand. All areas of the stand that come in contact with the propeller should be padded sufficiently to prevent abrasion damage to the propeller.
- (9) Install a protective cover over the propeller hub mounting flange.
- (10) Install a protective cover over the open end of the engine propeller flange.

McCAULEY PROPELLER SYSTEMS
OWNER/OPERATOR
INFORMATION MANUAL

D. Propeller Assembly Installation

NOTE: McCauley recommends that propeller mounting nuts (if applicable) be replaced at each propeller installation, whenever possible. However, nuts may be reused providing threads are in good condition and the locking material prevents turning of the nut on the stud by hand.

- (1) If required, attach bulkhead mounting ring or bulkhead to hub. Make sure the (felt tip pen) alignment marks between the bulkhead and the propeller blade are in alignment.
- (2) Remove the protective cover from the end of the engine propeller flange.
- (3) Ensure that engine propeller flange, hub mounting flange, dowels and holes, mounting studs and holes are clean, dry, and free of damage and foreign material.
- (4) Remove protective cover from the propeller hub mounting flange.
- (5) Ensure that a new McCauley O-ring (A-1633-3 or A-1633-49, Continental engines) (A-1633-11, Lycoming engines) is installed in the groove of the propeller hub mounting flange. Lubricate the O-ring with engine oil prior to installation of propeller.

NOTE: In the past, new propeller assemblies shipped from McCauley, the propeller hub/engine O-ring was installed in the O-ring groove of new propellers and hub assemblies. This practice has been discontinued. The O-ring is now included in the propeller unattached parts kit, which is included in the box with the propeller or hub assembly. Install the O-ring according to the assembly instructions in this Owner/Operator Manual.

- (6) Install the propeller sling and attach to a hoist. If a hoist is not available, the propeller may be supported and lifted by hand.

NOTE: Make sure an adequate number of people are available to support the propeller if a hoist is not used.

- (a) The straps of the propeller sling should be placed on two of the propeller blades at least 6 inches (152 mm) outboard of the propeller hub for three blade propellers and 12 inches (305 mm) outboard of the propeller hub for two bladed propellers. Make sure you protect the deice boots or anti-ice shoes from potential propeller sling abrasion damage, if installed.
- (b) The sling and hoist should have a weight limit rating at least twice the weight of the propeller that is to be installed.
- (7) Position the propeller close to the engine propeller flange and align the dowel pins with the dowel pin holes if applicable.

CAUTION: Propeller must be installed straight onto engine flange. Any rocking of propeller relative to flange could result in damage to engine/propeller flange mating surfaces.

- (8) Mount the propeller on the engine propeller shaft. Trap the aft spinner bulkhead between the hub and engine mounting flange if applicable. Make sure the index marks made with a felt tip pen align between the aft spinner bulkhead and the propeller blade.
- (9) Ensure threads of nuts and studs are free of burrs, nicks, and similar damage, and clean of foreign material.
 - (a) For Continental, Franklin, and Orenda engine installations:

McCAULEY PROPELLER SYSTEMS
OWNER/OPERATOR
INFORMATION MANUAL

WARNING: If the lubricant is not applied as required, the nuts will be under torqued, and the propeller could fail.

CAUTION: Do not use oil as a substitute for approved lubricant. It is imperative that the correct specification of lubricant be used during installation. Substitution of the approved grease with an unapproved lubricant (or no lubricant) could result in under-torquing or severe over-torquing of propeller attaching parts.

- 1 Lubricate the threads of studs and nuts and the faces of nuts, spacers, or washers with MIL-PRF-83483 (McCauley part number A-1637-16) grease.
- 2 Install mounting nuts on mounting studs.
- 3 Torque the mounting nuts in an alternating sequence to prevent the hub rocking on the engine flange.
- 4 When the hub is seated fully on the engine flange, torque to the specification called out in the mounting decal located on propeller hub at the number 1 socket.

NOTE: If the decal containing the propeller installation instructions is missing or illegible, install a new decal. For all applicable Continental engine installations use a part number A-2230-9 decal except installations that use the model 3FF32C501 propeller. The model 3FF32C501 propeller requires the part number A-2230-7 decal. All Franklin engine installations use a part number A-2230-9 decal. All Orenda engine installations use a part number A-2230-7 decal, refer to Table 401.

NOTE: McCauley C1 through C98 model propellers are not applicable to this manual, refer to McCauley Service Bulletin SB227B, or latest revision, for propeller mounting torque information for McCauley C1 through C98 model propellers.

- 5 After you apply the final torque, apply torque seal to nut and stud threads.
- (b) For Lycoming engine installations:

WARNING: Threads must be clean and dry. If any lubricant is applied, the attaching parts will be severely over-torqued.

- 1 Start threads on all propeller mounting nut and stud assembly and then tighten them in an alternating sequence to prevent the hub rocking on the engine flange.
- 2 When the hub is seated fully on the engine flange, torque to the specification called out on the mounting decal located on propeller hub at the number 1 socket.

NOTE: If the decal containing the propeller installation instructions is missing or illegible, install a new decal. For all Lycoming engine installations use a part number A-2230 decal except installations that use the model 3AF32C524 propeller. The model 3AF32C524 propeller requires the part number A-2230-9 decal Table 401.

- 3 Safety wire (0.041 corrosion resistant steel conforming to MS20995C41) the nuts in pairs to complete the installation.
- (c) If required, install the deice leads.
- (10) If an adaptor or extension is attached to torque wrench drive end and this adds to its length, then the actual applied torque will be greater than the dial reading. The following formula should be used to find what the dial should read in order to obtain the correct applied torque:

McCAULEY PROPELLER SYSTEMS
OWNER/OPERATOR
INFORMATION MANUAL

$$\frac{(\text{actual torque required}) \times (\text{torque wrench length})}{(\text{torque wrench length}) + (\text{length of the adapter})} = \text{Torque Wrench Reading to Achieve the Required Actual Torque}$$

E. Spinner Installation (if applicable)

CAUTION: Under-shimming or over-shimming of the spinner front support could result in spinner wobble, vibration, and/or bulkhead and spinner cracking. Follow shimming procedures carefully.

- (1) If required, install propeller spinner fillets on the bulkhead with screws and washers.
- (2) Insert the same number of shims into spinner support as were removed, and lightly press the spinner support onto propeller cylinder. Make sure the index marks made with a felt tip pen align between the spinner and the propeller blade.
- (3) Put the spinner shell onto the bulkhead and fillet assembly with the alignment marks matched.
 - (a) Press firmly aft on the spinner.
 - (b) Make sure the spinner holes are approximately one-half hole diameter forward of the matching holes in the bulkhead.
 - (c) Add or subtract shims to spinner support until spinner shell mounting holes are approximately half a hole from being in true alignment with bulkhead holes.
- (4) Push on the spinner shell and use an awl or a small punch in an adjacent hole to move the spinner shell screw hole into alignment with bulkhead hole and install washer and screw. Repeat this procedure on opposing holes until eight evenly spaced screws and washers are installed.
- (5) Secure propeller spinner to the bulkhead and fillet assemblies with remaining screws and washers.

5. **C600/C650/C1100 Series Propeller Removal and Installation**

A. General

- (1) Propeller removal and installation shall be performed only by qualified maintenance personnel. The following instructions are general in nature. The aircraft maintenance manual or STC installation instructions should always be consulted for any specialized procedures applicable to a specific aircraft. Various spinner and deice arrangements not manufactured by McCauley may be used which require additional procedures.

NOTE: Qualified maintenance personnel means the person doing the maintenance activity is the holder of, or is working under the direct supervision of, the holder of the appropriate rating to approve the propeller for return to service after the maintenance activity has been accomplished.

- (2) In the following instructions, installation of propeller is based on the assumption that a McCauley spinner will be used. If a spinner is not used or if the spinner is not manufactured by McCauley, omit those steps which apply to the spinner.

B. Spinner Assembly Removal

- (1) Make an alignment mark on the spinner, aft spinner bulkhead and an adjacent blade with a felt tip pen. This index mark insures accurate restoration of spinner position to lessen the distortion of any dynamic balance previously performed on the propeller assembly.
- (2) Remove screws and washers from spinner and fillet assemblies.
- (3) Remove spinner from the bulkhead and fillet assemblies.
- (4) Remove spinner support and shims from spinner.
- (5) Remove screws and washers attaching fillets to the bulkhead and remove the fillets.

C. Propeller Assembly Removal

NOTE: Propeller must be on start locks when beginning this procedure.

- (1) Position power lever to full reverse position.

McCAULEY PROPELLER SYSTEMS
OWNER/OPERATOR
INFORMATION MANUAL

- (2) Activate the propeller unfeathering pump.

NOTE: Do not operate the unfeathering pump more than one minute when oil is cold. Restrict operation to 30 seconds maximum when oil is hot.

- (a) The propeller blades will move toward reverse pitch and unload the start locks.
- (b) Insert start lock release tools (P/N B-5021) in the four holes on the front (forward end) of the propeller cylinder. Refer to Figure 404.
- (c) The tools will move the start lock weights outboard and disconnect the latch from the piston.

NOTE: The start lock release tools should be inserted by hand with a light push. Do not hammer on or forcibly insert the start lock release tools.

- (3) With the propeller blades off of the start locks and the propeller is in full reverse, quickly loosen the beta tube locking screw at the end of the beta tube. Tap the locking pin out of piston rod/ beta tube and remove the locking plug from the beta tube.
- (4) Release (shut off) the unfeathering pump.
- (a) The blades will start moving toward the feather position.

NOTE: You should hear a faint click as the start locks ride on the start lock release tools and pass over the latch position.

- (5) Remove start lock release tool. The propeller is now free of the start locks and will be in the feather position.
- (6) Use the McCauley beta tube adjustment tool part number B-5378 to unscrew the beta tube. Refer to Figure 404.

CAUTION: Never use a screwdriver or other unapproved tool to remove the beta tube. Use of any tool other than McCauley B-5378 can severely damage beta tube and propeller piston rod threads, rendering parts unusable and unrepairable.

- (a) Count the number of turns that are required to remove the beta tube. Record the number of turns required to free the beta tube for future reference when the propeller is to be installed.
- (7) Once the beta tube is free from all threads, the o-ring will create friction between the piston rod and the beta tube. To overcome the o-ring friction, continue to turn the beta tube counterclockwise while gently pulling on the beta tube removal tool.

CAUTION: Do not grab the beta tube with pliers or anything which could damage the threads of the beta tube.

- (8) Pull the beta tube out and handle very carefully. Wipe the beta tube with a clean rag and store in a safe place.
- (9) Place a drip pan under the propeller mounting surface to catch any spilled engine oil when the propeller is removed.
- (10) Break the torque on the propeller mounting nuts. (McCauley Torque Wrench Adapter part number B-5588 may be used to gain easier access to mounting nuts). Refer to Figure 403.
- (11) Install a propeller sling and attach to hoist. If hoist is unavailable, propeller may be supported and lifted by hand. This will require additional personnel.

CAUTION: The C600 propellers weigh approximately 120 pounds (54 kg) and the C650 propellers approximately 160 pounds (73 kg). C1100 series propellers weigh 180 pounds (83 kg) or more.

- (a) Hoist straps must be a minimum of 4 inches (100 mm) wide.

McCAULEY PROPELLER SYSTEMS
OWNER/OPERATOR
INFORMATION MANUAL

- (b) The straps of the propeller sling should be placed on two of the propeller blades at least 6 inches (152 mm) outboard of the propeller hub. Make sure you protect the deice boots or anti-ice shoes from potential propeller sling abrasion damage, if installed.
- (12) The sling and hoist should have a weight limit rating at least twice the weight of the propeller that is to be removed.
- (13) Take up the slack on the propeller sling and hoist, or have at least four persons support the propeller, and remove the nuts.
- (14) Carefully slide the propeller forward and remove from the engine.
- (15) Place the propeller on a suitable support or propeller stand.
 - (a) Do not let the propeller be supported by the tips of the propeller blades or "stand" the propeller on the propeller blade tips.
 - (b) The stand should be able to hold the propeller securely and have a weight limit rating at least twice that of the removed propeller.
 - (c) Make sure the propeller is protected from damaged while in the stand. All areas of the stand that come in contact with the propeller should be padded sufficiently to prevent abrasion damage to the propeller.
- (16) Install a protective cover over the propeller hub mounting flange.
- (17) Install a protective cover over the open end of the engine propeller flange.

D. Propeller Installation

NOTE: McCauley recommends that the propeller mounting nuts (McCauley part number A-1639-32) be replaced at each propeller installation, whenever possible. However, nuts may be reused if the locking material prevents turning of the nut on the stud by hand.

- (1) Remove protective cover from the end of engine propeller flange.
- (2) Make sure the flange is clean and free of nicks and burrs.
- (3) Make sure that the engine propeller flange, dowels, and mounting stud holes are clean, dry, and free of nicks and burrs.
- (4) Remove the protective cover from the propeller hub mounting flange.
- (5) Make sure that the propeller hub mounting flange, dowel pin holes, and mounting studs are clean and undamaged.
- (6) Make sure that a new O-ring is installed in the groove of propeller hub mounting flange. Lubricate the O-ring with engine oil prior to installation of propeller.

NOTE: Refer to the Installation Parts For Turbine Engine Propellers, Table 1002 for the O-ring part number.

NOTE: In the past, new propeller assemblies shipped from McCauley, the propeller hub/engine O-ring was installed in the O-ring groove of new propellers and hub assemblies. This practice has been discontinued. The O-ring is now included in the propeller unattached parts kit, which is included in the box with the propeller or hub assembly. Install the O-ring according to the assembly instructions in this Owner/Operator Manual.

- (7) Use a propeller sling and hoist, or additional personnel, to position the propeller close to the engine propeller flange and align engine flange dowel pins with the dowel pin holes on the propeller hub mounting flange. Rotate engine propeller mounting flange as required to align the dowel pin holes.
 - (a) Hoist straps must be a minimum of 4 inches (100 mm) wide.
 - (b) The sling and hoist should have a weight limit rating at least twice the weight of the propeller that is to be installed.
 - (c) The straps of the propeller sling should be placed on two of the propeller blades at least 6 inches (152 mm) outboard of the propeller hub. Make sure you protect the deice boots or anti-ice shoes from potential propeller sling abrasion damage, if installed.

McCAULEY PROPELLER SYSTEMS
OWNER/OPERATOR
INFORMATION MANUAL

CAUTION: Propeller must be installed straight onto the engine flange. Any rocking of the propeller with respect to the flange could result in damage to the engine/propeller flange mating surfaces.

- (8) Mount the propeller on the engine propeller shaft.
- (9) Ensure threads of nuts and studs are free of burrs, nicks, and similar damage, and clean of foreign material.

WARNING: If the lubricant is not applied as required, the nuts will be under torqued, and the propeller could fail.

- (a) For Garrett (Honeywell) engine installations:

CAUTION: Do not use oil as a substitute for approved lubricant. It is imperative that the correct specification of lubricant be used during installation. Substitution of the approved grease with an unapproved lubricant (or no lubricant) could result in under-torquing or severe over-torquing of propeller attaching parts.

- 1 Lubricate the threads of studs and nuts and the faces of nuts, spacers, or washers with MIL-PRF-83483 (McCauley part number A-1637-16) grease.
- 2 Install mounting nuts on mounting studs.
- 3 Torque the mounting nuts in an alternating sequence to prevent the hub rocking on the engine flange.
- 4 When the hub is seated fully on the engine flange, torque to the specification called out in the mounting decal located on propeller hub at the number 1 socket.

NOTE: If the decal containing the propeller installation instructions is missing or illegible, install a new decal. All Garrett (Honeywell) engine installations, use a part number A-2230-7 decal. The A-2230-7 decal specifies a lubricated 68 to 72 foot-pounds (92.196 to 97.619 N-m) torque.

- a McCauley Torque Wrench Adapter:

CAUTION: If an adaptor or extension (such as McCauley part number B-5588) is attached to torque wrench drive end and this adds to its length, then the actual applied torque will be greater than the dial reading. The following formula should be used to find what the dial should read in order to obtain the correct applied torque:

$$\text{Dial Reading} = \frac{\text{Torque Wrench Length} \times \text{Desired Torque}}{\text{Torque Wrench Length} + \text{Extension Length}}$$

- 5 After you apply the final torque, apply torque seal to nut and stud threads.
 - (b) If required, install the deice leads.
- (10) Install the beta tube.

McCAULEY PROPELLER SYSTEMS
OWNER/OPERATOR
INFORMATION MANUAL

CAUTION: Never use a screwdriver or similar tool to install the beta tube. Use of any tool other than McCauley B-5378 can severely damage beta tube and propeller piston rod threads, rendering parts unusable and unrepairable.

- (a) Lubricate with turbine oil and install a new O-ring (Garrett part) on beta tube and install using McCauley Beta Tube Adjustment Tool (part number B-5378).
 - 1 Once the beta tube threads are engaged, turn the beta tube the same amount of turns that were required to remove the beta tube. If the number of turns required to remove the beta tube is not known, use 32 turns.
- (11) Make sure of proper rigging of engine controls. Refer to the aircraft maintenance manual.
- (12) Do a propeller flight idle blade angle check.

NOTE: Refer to the airplane maintenance manual, airplane type certificate (TC), Supplemental Type Certificate (STC) and the propeller type certificate as required for the flight idle propeller blade angle.

- (a) Place the base of the protractor on the top of the propeller cylinder and align it longitudinally to zero the propeller protractor.
- (b) Position power lever at the flight idle position.
- (c) Activate the unfeathering pump. As oil pressure increases, the propeller blades will rotate from feather towards the flight idle position.

NOTE: Do not operate the unfeathering pump more than one minute when oil is cold. Restrict operation to 30 seconds maximum when oil is hot.

- (d) When the propeller blades have stopped in the flight idle position, move the blade to be tested so the leading edge is up and blade is horizontal.

NOTE: It is required to check the blade angle of only one blade.

- (e) With the unfeathering pump still operating, use a propeller protractor to measure the propeller blade angle at the station indicated by a white or yellow mark on rear surface of the propeller blade (usually will be the 30 inch or 42 inch station).

CAUTION: Never use a screwdriver or other unapproved tool to adjust beta tube. Use of any tool other than McCauley B-5378 can severely damage the beta tube and propeller piston rod threads, rendering the parts unusable and unrepairable.

CAUTION: Adjustment of the flight idle blade angle must be accomplished as quickly as possible as not to deplete the propeller oil supply.

- (f) If adjustment is necessary, use McCauley tool, part number B-5378, to adjust the beta tube. Turn the beta tube clockwise to decrease blade angle, counterclockwise to increase blade angle.
 - (g) Move propeller control to full reverse and install the beta tube locking pin assembly and secure with locking screw (55) torque 25 to 30 inch-pounds (2.82 to 3.39 N-m).
- (13) Feather, start lock, and reverse, blade angles are set during assembly or overhaul. These angles are NOT adjustable in the field.

McCAULEY PROPELLER SYSTEMS
OWNER/OPERATOR
INFORMATION MANUAL

CAUTION: Do not operate the propeller below the minimum propeller idle speed operating restriction. The minimum propeller idle speed operating restriction is the result of a specific vibratory resonant condition known as "reactionless mode". Ground operation, at or near a reactionless mode vibratory resonance speed, can cause very high stresses in the propeller blades and hubs. These high stresses are more severe when operating in a tailing wind condition. If the propeller is operated within a restricted RPM range or below a minimum RPM restriction for an extended period of time, the propeller blades and hubs may become unairworthy due to fatigue. Hub or blade failure has the potential of causing a catastrophic event due to blade separation. The propeller RPM restriction is often placed below the minimum idle RPM; however, certain aircraft have a restriction that is above the propeller idle RPM setting. Either restriction is important. The propeller operating restrictions or limitations may be found in the Airplane Flight Manual (AFM) or Airplane Flight Manual Supplement (AFMS). The propeller installations may be controlled by the various airframe manufacturers Type Certificate (TC) or by Supplemental Type Certificate (STC).

E. Spinner Installation

CAUTION: Undershimming or overshimming of the spinner aft bulkhead could result in spinner wobble, vibration, and/or bulkhead and spinner cracking. Please follow shimming procedures carefully.

- (1) Install propeller spinner fillets on the bulkhead with screws and washers if required.
- (2) Insert shims into the spinner support and lightly press spinner support onto the cylinder on the front end of the propeller.
- (3) Mount the spinner onto the bulkhead and fillet assembly and check alignment of the mounting holes in the spinner and bulkhead.
 - (a) Make sure that alignment marks on the spinner and propeller blade are matched.
 - (b) Add or subtract shims to the spinner support until spinner mounting holes are aligned within one-half hole with the bulkhead mounting hole diameters while you push hard on the spinner shell.
- (4) Use an awl or a small punch in an adjacent hole to move the spinner screw hole into alignment with the bulkhead hole and install the screw. Repeat the procedure on opposing holes until eight equally spaced screws and washers are installed.
- (5) Secure the propeller spinner to the bulkhead and fillet assemblies with the remaining screws and washers.

6. C700/C750/C1000 Propeller Removal/Installation

A. General

- (1) Propeller removal and installation should be performed only by qualified maintenance personnel. The following instructions are general in nature. The aircraft maintenance manual or STC installation instructions should always be consulted for any specialized procedures applicable to a specific aircraft. Various spinner and deice arrangements not manufactured by McCauley may be used which require additional procedures.

NOTE: Qualified maintenance personnel means the person doing the maintenance activity is the holder of, or is working under the direct supervision of, the holder of the appropriate rating to approve the propeller for return to service after the maintenance activity has been accomplished.

McCAULEY PROPELLER SYSTEMS
OWNER/OPERATOR
INFORMATION MANUAL

C72

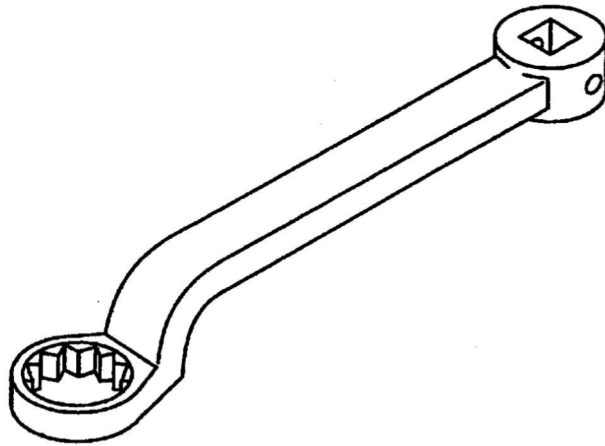

Propeller Torque Wrench Adapter Tool
Figure 403 (Sheet 1)

McCAULEY PROPELLER SYSTEMS
OWNER/OPERATOR
INFORMATION MANUAL

C71

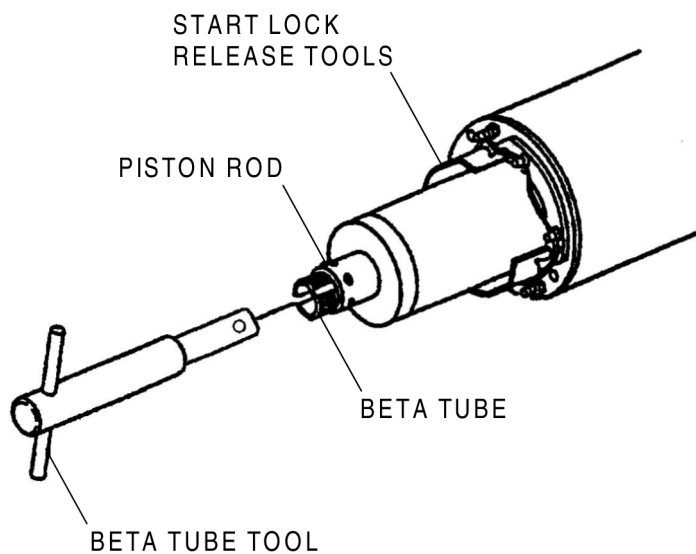

Propeller Beta Adjustment and Start Lock Release Tools
Figure 404 (Sheet 1)

McCAULEY PROPELLER SYSTEMS
OWNER/OPERATOR
INFORMATION MANUAL

- (2) In the following instructions, installation of propeller is based on the assumption that a McCauley spinner will be used. If a spinner is not used or if the spinner is not manufactured by McCauley, omit those steps which apply to the spinner.

B. Spinner Assembly Removal

- (1) Make an alignment mark on the spinner, spinner aft bulkhead and an adjacent blade with a felt tip pen. This index mark insures accurate restoration of spinner position to lessen the distortion of any dynamic balance previously performed on the propeller assembly.
- (2) Remove screws and washers from spinner and fillet assemblies.
- (3) Remove spinner from the bulkhead and fillet assemblies.
- (4) Remove spinner support and shims from spinner.
- (5) Remove screws and washers attaching fillets to the bulkhead and remove the fillets.

C. Propeller Assembly Removal

- (1) Make sure the airplane propeller control lever has the FEATHER position selected and the propeller blades are in feather.

NOTE: If the propeller control lever is not in the FEATHER position or the propeller blades are not in feather, consult the Pilot's Operating Handbook for instructions to put the propeller control in the feather position and to feather the propeller.

- (2) Place a drip pan under the propeller mounting surface to catch any spilled engine oil when the propeller is removed.
- (3) Remove the feedback bearing assembly from the feedback collar groove. Refer to the aircraft or engine manual for procedure.
- (4) Remove the cowling as required for access to the mounting nuts.
- (5) Install the D-5945 feedback collar retractor tool to the beta rods.

NOTE: Make sure the rods are inserted through the correct holes of the tool. The beta rods must be pulled directly forward.

CAUTION: Do not draw the feedback collar too far forward as the beta rods will be damaged.

- (6) Turn the large threaded rod of the retractor tool clockwise to draw the feedback collar forward to allow access to the propeller mounting nuts.
- (7) Break the torque on the propeller mounting nuts. (McCauley Torque Wrench Adapter part number B-5588 may be used to gain easier access to mounting nuts.) (Refer to Figure 201).
- (8) Install propeller sling and attach to hoist. If hoist is unavailable, propeller may be supported and lifted by hand. This will require additional personnel.

CAUTION: The C700 propellers weigh approximately 120 pounds (54 kg), the C750 propellers approximately 140 pounds (64 kg). C1000 series propellers weigh 180 pounds (83 kg) or more.

- (a) Hoist straps must be a minimum of 4 inches (100 mm) wide.
 - (b) The sling and hoist should have a weight limit rating at least twice the weight of the propeller that is to be removed.
 - (c) The straps of the propeller sling should be placed on two of the propeller blades at least 6 inches (152 mm) outboard of the propeller hub. Make sure you protect the deice boots or anti-ice shoes from potential propeller sling abrasion damage, if installed.
- (9) Take up the slack on the propeller sling and hoist, or have additional personnel support the propeller, and remove the nuts.
 - (10) Carefully slide the propeller forward and remove from the engine.
 - (11) Place the propeller on a suitable support or propeller stand.
 - (a) Do not let the propeller be supported by the tips of the propeller blades or "stand" the propeller on the propeller blade tips.

McCAULEY PROPELLER SYSTEMS
OWNER/OPERATOR
INFORMATION MANUAL

- (b) The stand should be able to hold the propeller securely and have a weight limit rating at least twice that of the removed propeller.
 - (c) Make sure the propeller is protected from damaged while in the stand. All areas of the stand that come in contact with the propeller should be padded sufficiently to prevent abrasion damage to the propeller.
- (12) Install a protective cover over the propeller hub mounting flange.
 - (13) Install a protective cover over the open end of the engine propeller flange.
 - (14) Remove the D-5945 feedback collar retractor tool from the propeller.

D. Propeller Installation

NOTE: McCauley recommends that the propeller mounting nuts (McCauley part number A-1639-32) be replaced at each propeller installation, whenever possible. However, nuts may be reused if the locking material prevents turning of the nut on the stud by hand.

- (1) Install the D-5945 feedback collar retractor tool on the propeller.
- (2) Remove protective cover from the end of engine propeller flange.
- (3) Make sure the flange is clean and free of nicks and burrs.
- (4) Make sure that the engine propeller flange, dowels, and mounting stud holes are clean, dry, and free of nicks and burrs.
- (5) Remove the protective cover from the propeller hub mounting flange.
- (6) Make sure that the propeller hub mounting flange, dowel pin holes, and mounting studs are clean and undamaged.
- (7) Make sure that a new O-ring is installed in the groove of the propeller hub mounting flange. Lubricate the O-ring with engine oil prior to installation of the propeller.

NOTE: Refer to the Installation Parts For Turbine Engine Propellers, Table 1002 for the O-ring part number.

NOTE: In the past, new propeller assemblies shipped from McCauley, the propeller hub/engine O-ring was installed in the O-ring groove of new propellers and hub assemblies. This practice has been discontinued. The O-ring is now included in the propeller unattached parts kit, which is included in the box with the propeller or hub assembly. Install the O-ring according to the assembly instructions in this Owner/Operator Manual.

- (8) Use a propeller sling and hoist, or additional personnel, to position the propeller close to the engine propeller flange and align engine flange dowel pins with the dowel pin holes on the propeller hub mounting flange. Rotate engine propeller mounting flange as required to align the dowel pin holes.
 - (a) Hoist straps must be a minimum of 4 inches (100 mm) wide.
 - (b) The sling and hoist should have a weight limit rating at least twice the weight of the propeller that is to be installed.
 - (c) The straps of the propeller sling should be placed on two of the propeller blades at least 6 inches (152 mm) outboard of the propeller hub. Make sure you protect the deice boots or anti-ice shoes from potential propeller sling abrasion damage, if installed.

CAUTION: Propeller must be installed straight onto the engine flange. Any rocking of the propeller with respect to the flange could result in damage to the engine/propeller flange mating surfaces.

- (9) Mount the propeller on the engine propeller shaft.
- (10) Make sure the alignment mark on the spinner aft bulkhead and the propeller blade with are in alignment.
- (11) Ensure threads of nuts and studs are free of burrs, nicks, and similar damage, and clean of foreign material.

McCAULEY PROPELLER SYSTEMS
OWNER/OPERATOR
INFORMATION MANUAL

WARNING: If the lubricant is not applied as required, the nuts will be under torqued, and the propeller could fail.

- (a) For Pratt & Whitney engine installations:

CAUTION: Do not use oil as a substitute for approved lubricant. It is imperative that the correct specification of lubricant be used during installation. Substitution of the approved grease with an unapproved lubricant (or no lubricant) could result in under-torquing or severe over-torquing of propeller attaching parts.

- 1 Lubricate the threads of studs and nuts and the faces of nuts, spacers, or washers with MIL-PRF-83483 (McCauley part number A-1637-16) grease.
- 2 Install mounting nuts on mounting studs.
- 3 Torque the mounting nuts in an alternating sequence to prevent the hub rocking on the engine flange.
- 4 When the hub is seated fully on the engine flange, torque to the specification called out in the mounting decal located on propeller hub at the number 1 socket.

NOTE: If the decal containing the propeller installation instructions is missing or illegible, install a new decal. All Pratt & Whitney engine installations, use a part number A-2230-7 decal. The A-2230-7 decal specifies a lubricated 68 to 72 foot-pounds (92.196 to 97.619 N-m) torque.

- 5 After you apply the final torque, apply torque seal to nut and stud threads.
- (b) If required, install the deice leads.
- (12) McCauley Torque Wrench Adapter:

CAUTION: If an adaptor or extension (such as McCauley part number B-5588) is attached to torque wrench drive end and this adds to its length, then the actual applied torque will be greater than the dial reading. The following formula should be used to find what the dial should read in order to obtain the correct applied torque:

$$\text{Dial Reading} = \frac{\text{Torque Wrench Length} \times \text{Desired Torque}}{\text{Torque Wrench Length} + \text{Extension Length}}$$

- (13) Remove the D-5945 feedback collar retractor tool from the propeller.
- (14) Make sure of proper rigging of engine controls. Refer to aircraft maintenance manual or STC maintenance manual supplement.
- (a) Feather, reverse, and low blade angles are set during assembly or overhaul. These angles are NOT adjustable in the field.

McCAULEY PROPELLER SYSTEMS
OWNER/OPERATOR
INFORMATION MANUAL

CAUTION: Do not operate the propeller below the minimum propeller idle speed operating restriction. The minimum propeller idle speed operating restriction is the result of a specific vibratory resonant condition known as "reactionless mode". Ground operation, at or near a reactionless mode vibratory resonance speed, can cause very high stresses in the propeller blades and hubs. These high stresses are more severe when operating in a tail-wind condition. If the propeller is operated within a restricted RPM range or below a minimum RPM restriction for an extended period of time, the propeller blades and hubs may become unairworthy due to fatigue. Hub or blade failure has the potential of causing a catastrophic event due to blade separation. The propeller RPM restriction is often placed below the minimum idle RPM; however, certain aircraft have a restriction that is above the propeller idle RPM setting. Either restriction is important. The propeller operating restrictions or limitations may be found in the Airplane Flight Manual (AFM) or Airplane Flight Manual Supplement (AFMS). The propeller installations may be controlled by the various airframe manufacturers Type Certificate (TC) or by Supplemental Type Certificate (STC).

E. Spinner Installation

CAUTION: Undershimming or overshimming of the spinner aft bulkhead could result in spinner wobble, vibration, and/or bulkhead and spinner cracking. Please follow shimming procedures carefully.

- (1) Install propeller spinner fillets on the bulkhead with screws and washers if required.
- (2) Insert shims into the spinner support and lightly press spinner support onto the cylinder on the front end of the propeller.
- (3) Mount the spinner onto the bulkhead and fillet assembly and check alignment of the mounting holes in the spinner and bulkhead.
 - (a) Make sure that alignment marks on the spinner and propeller blade are matched.
 - (b) Add or subtract shims to the spinner support until spinner mounting holes are aligned within one-half hole with the bulkhead mounting hole diameters while you push hard on the spinner shell.
- (4) Use an awl or a small punch in an adjacent hole to move the spinner screw hole into alignment with the bulkhead hole and install the screw. Repeat the procedure on opposing holes until eight equally spaced screws and washers are installed.
- (5) Secure the propeller spinner to the bulkhead and fillet assemblies with the remaining screws and washers.

McCAULEY PROPELLER SYSTEMS
OWNER/OPERATOR
 INFORMATION MANUAL

PROPELLER ADJUSTMENT/TEST

1. Static Balance

- A. Checking and adjusting the propeller static balance shall be accomplished by an FAA approved Part 145 Propeller Repair Station or international equivalent.

2. Propeller Pressure Leakage Check Requirements

- A. Propeller pressure leakage tests of the cylinder and the hub shall be accomplished by an FAA approved Part 145 Propeller Repair Station or international equivalent.

3. Ground Support Equipment

- A. The following special equipment is required for field maintenance of McCauley propellers.

NAME	PART NUMBER	MANUFACTURER	USE
Propeller protractor		Commercially available	To measure blade angles on 600, 650, and 1100 Series propellers.
Start lock release tools	B-5021	McCauley	To release start locks on C600, C650, and C1100 series propellers.
Beta tube installation and adjustment tool	B-5378	McCauley	To install and adjust beta tube on C600, C650, and C1100 series propellers.

4. Flight Idle Blade Angle/Flight Idle Torque Checking and Adjustment Procedures (Turbine Series Propellers)

- A. Flight Idle Blade Angle Checking and Adjustment Procedure
 - (1) Check the blade angles are within the limits specified in the FAA Aircraft Type Certificate Data Sheets or STC.
 - (2) The adjustment of the flight idle blade angle or flight idle torque is in accordance with the airplane maintenance instructions or STC instructions.
 - (a) Make sure the propeller blade angles or flight angle torque are within the limits specified in the FAA Aircraft Type Certificate Data Sheets or STC.

NOTE: Transient operation below the minimum RPM limitation is permitted during feathering and unfeathering cycles.

5. Dynamic Balance

NOTE: Some aircraft manufacturers do not approve dynamic balance of the propeller because of potential crack damage to spinner bulkhead from the installed weight.

- A. Refer to Propeller Maintenance Practices, Dynamic Balance for instructions to dynamically balance the installed propeller.

McCAULEY PROPELLER SYSTEMS
OWNER/OPERATOR
INFORMATION MANUAL

PROPELLER INSPECTION/CHECK

1. Limitations

- A. Operational and service personnel should be familiar with the following limitations during any inspection.
- B. Corrosion. Other than small areas of light surface corrosion with no evidence of pitting, the presence of corrosion may require propeller removal and reconditioning by an appropriately rated repair facility. Intergranular corrosion may be present when the corrosion protective coatings (paint, anodize, etc.) have been lost. Corrosion pitting should be removed as described in the overhaul manual and applicable ADs.
- C. Unauthorized Straightening of Blades.
 - (1) A bent propeller cannot be straightened without special processing in an FAA approved Part 145 Propeller Repair Station or international equivalent because bending may harden the aluminum and lead to catastrophic blade failure.
 - (2) All blades showing evidence of unapproved repairs require removal of the entire propeller and proper assessment by an FAA approved Part 145 Propeller Repair Station or international equivalent.
 - (3) Sighting along the leading edge of a propeller blade for any signs of bending can also provide evidence of unapproved blade straightening.
 - (4) Any deformation of the flat portion such as bows or kinks may indicate previous unauthorized straightening of the blade.
 - (5) Careful visual inspection of the leading edges and the flat-faced portion of the blade may sometimes detect unapproved repairs.
 - (6) Blades should also be examined for any discoloration that would indicate unauthorized heating.
 - (a) Aluminum blades that have been heated for any repair must be removed from service since only cold (room temperature) straightening by an FAA approved Part 145 Propeller Repair Station or international equivalent repair facility is authorized.
 - (7) Field service personnel should never straighten bent propellers to facilitate shipping when the propellers are being sent to a repair facility for inspection and repair. This procedure can conceal important information related to the severity of the damage.
- D. Blade Shortening.
 - (1) Propeller tip damage will sometimes lead field maintenance personnel to consider removing damaged material from the blade tips. However, propellers are certified to the aircraft engine and airframe resonant frequency by being manufactured with a particular diameter to minimize vibration. Shortening of the blades without reference to approved data could create an unairworthy condition. Refer to the airplane type certificate data sheet, aircraft specification sheet, or supplemental type certificate data sheet as applicable, for the allowable propeller diameter for each propeller installation.
 - (2) With certain limitations, specific minor repairs may be accomplished.
 - (a) If the blade tip has been damaged and the removal of the damaged area would result in shortening of the propeller blade(s), the propeller shall be taken to an FAA approved Part 145 Propeller Repair Station or international equivalent, for propeller blade repair.
 - (b) When conditions indicate, inspect the blade tips for evidence of shortening and, if necessary, measure the propeller diameter to determine if an unauthorized repair has altered it.

2. Definitions of Defects and Damage

- A. Brinelling is the occurrence of shallow, spherical depressions in a surface, usually produced by a part having a small radius in contact with the surface under high load.
- B. A Burr is a small, thin section of metal which extends beyond the edge of a regular surface and usually is located on a corner of, or on the edge of, a bore or hole.
- C. Corrosion is the loss of surface metal by a chemical or electrochemical action, and the resulting product (for example, iron rust) usually can be removed mechanically.

McCAULEY PROPELLER SYSTEMS
OWNER/OPERATOR
INFORMATION MANUAL

- D. A Crack is an irregularly shaped separation within a material at a location of excessive stress and usually is visible as a thin line across the surface of the material.
- E. A Cut is a mechanical loss of metal (e.g., by saw blade, chisel, or glancing blow of a sharp-edge stone), usually extending to a significant depth over a relatively long, narrow area.
- F. A Dent is a depression in a metal surface caused by an object striking the surface with force.

NOTE: The surface around the dent usually will be slightly deformed.

- G. Distortion or bending is the alteration of a component's original size or shape.
- H. Erosion is the gradual wearing away or deterioration of a material due to action of the elements.
- I. Exposure is leaving a material open to action of the elements.
- J. Fretting is the occurrence of shallow, spherical surface depressions, usually caused by vibratory ("chattering") action or by a part which has a small radius in contact under high load with the material.
- K. Galling (or burnishing) is the breakdown (or buildup) of a metal surface resulting from excessive friction between two moving parts.

NOTE: Particles of the softer metal tear loose (breakdown) and weld to the surface of the harder metal (buildup).

- L. A Gouge is a small surface area where material has been removed by contact with a sharp object.
- M. Impact damage occurs either in-flight or on the ground when a propeller blade or hub assembly strikes or is struck by an object.
- N. An Inclusion is the presence of an unspecified material that was introduced into a portion of stock metal during manufacturing processes such as rolling or forging.
- O. A Nick is a localized break or edge notch, usually with displacement of (rather than loss of) metal.
- P. Pitting is seen as a number of extremely small (possibly deep) gouges, usually with defined edges, caused by wear and/or deterioration on the surface of a material.
- Q. A Score is deeper than a gouge and may show discoloration from the temperature produced by friction from contact under pressure.
- R. A Scratch is an elongated Gouge.
- S. A Stain is a localized color change noticeably different from the surrounding surface area.

3. Daily or Preflight Inspection

- A. Oil and Grease Leakage.
 - (1) Look for red oil or engine lubricant leaks in unusual places, like the outside surfaces and seals.
 - (2) Oil or grease leakage may be due to a seal failure or a crack in the hub or blade.
 - (a) The source of the oil or grease leak should be determined before flight.
 - (b) During maintenance, wipe the surfaces of the propeller after this inspection, not before, since oil leaking from a crack may assist in detecting it.
 - (c) Red oil gives a positive warning of a crack in the hub or a damaged seal.
- B. Blade inspection.
 - (1) Wash the blades with a mild soap and water solution to remove all residue.

CAUTION: Do not use solvents to clean the blades.

- (a) Do not power wash as water may be forced past the O-rings. Water inside the hub will cause corrosion and may cause propeller failure.
- (b) Make sure the blade that you are cleaning is pointing down.
- (c) Do not spray into the blade retention area because water may be forced into the hub.

McCAULEY PROPELLER SYSTEMS
OWNER/OPERATOR
INFORMATION MANUAL

- (2) Surface Damage.
 - (a) Look for surface damage on both sides of the blades such as dents, nicks, scratches, and corrosion.
 - (b) Surface imperfections can also be felt by running your fingernail along the blade leading edge. Damage should be repaired before flight.
 - (c) Whenever a noticeable dent, nick, corrosion pit, or bump is observed, an appropriately rated mechanic should blend it out.
 - (d) The mechanic should remove all corrosion products and make sure that the section thickness has not been reduced below allowable limits.
- (3) Erosion.
 - (a) Examine the blade for evidence of erosion.
 - 1 If blades appear to show erosion beyond limits, the propeller should be removed from service and evaluated by an appropriately rated propeller repair facility.
 - 2 Measure the area of the blade with the most erosion damage.
 - a Damage that is located on the leading or trailing edges must not exceed 0.094 inch (2.39 mm) in depth.
 - b Damage that is located on a repairable area of the face or camber side of the blade must not exceed 0.061 inch (1.55 mm) in depth.
 - 3 Erosion damage beyond these limits is not field repairable and the propeller should be removed from service and evaluated by an FAA approved Part 145 Propeller Repair Station or international equivalent repair facility.
 - (b) Check the condition of the paint on blades and spinners that have protective paint.
 - 1 Paint protects the surface of the blade from erosion. The blade should be repaired before the paint wears through and the blade structure begins to erode.
 - 2 Do not apply excessive paint and do not paint propeller components unless it is in accordance with McCauley instructions since improper painting may affect propeller balance, operation, static electricity discharge, or have other unintended consequences.
- (4) Straightness.
 - (a) Sight down the edges to find any deformation.
- (5) Looseness.
 - (a) Feel the blades and move them to find unusual changes in looseness and unusual play.
 - 1 Blade-to-blade differences indicate that an internal problem may exist.

C. Spinner and Bulkhead.

- (1) Externally check the spinner and bulkhead for security, missing fasteners, damage, and cracks. Cracks typically originate from the attachment screws.
 - (a) Repair of cracks is not permitted.
- (2) Check for looseness of the bulkhead. This could be an indication that the mounting bolts are loose.
- (3) Wear depth on the inside of the spinner must not exceed 0.010 inch (0.25 mm).

NOTE: Wear inside the spinner can be caused by improper shimming of the spinner or by debris leads rubbing.

D. General Condition.

E. Control System.

- (1) The control system (governor) should be checked to determine whether the system is operating properly and is not leaking.

F. Maintenance Records.

- (1) Note any indications in the logbook for future reference to determine whether a condition is getting worse.

4. 100 Hour and Annual Inspection

- A. At each 100 hours, Annual, or other approved inspection interval, examine the propeller in accordance with aircraft inspection manual. Inspection should include:

- (1) Spinner Removal.

McCAULEY PROPELLER SYSTEMS
OWNER/OPERATOR
INFORMATION MANUAL

- (2) Inspection of all attaching hardware, including the hardware under the spinner, for security. Tighten if necessary.
- (3) Check entire propeller for corrosion, cracks, or other damage. Contact a McCauley Service Center for disposition if any unusual damage is found.
- (4) Inspect entire propeller system for oil leakage. If leakage is confirmed, the propeller should be removed, thoroughly inspected, and resealed by an FAA approved Part 145 Propeller Repair Station or international equivalent or technician.
- (5) Repaint propeller blades, as necessary, in accordance with the instructions in Cleaning/Painting/Protective Treatments.
- (6) Examine all placards for legibility and security of installation. Replace all placards that are illegible or not secure.

5. Time Between Propeller Overhaul

- A. The following pages show McCauley's mandatory specified time between overhaul for propellers. These specifications are based on hours of operation and calendar time, whichever occurs first. The starting point for the calendar limit is the date of first installation on an engine (not from date of manufacture or overhaul). Date of manufacture or overhaul is applicable when determining long term storage inspections. If the propeller has been removed from service, the TBO calendar limit still applies, not long term storage.

NOTE: Calendar month is the period of time from the first day of a month to the last day of the month. When the term calendar month is used, compliance can be achieved at any time during the month, up to and including the last day of the month. For Example: a propeller with a 60 calendar month inspection interval is inspected and approved upon any given day of the month. This propeller will become due for inspection upon the last day of the same month, 60 months later.

- B. All deviations from published TBOs must be approved by your local Regulatory Authority with a recommendation from McCauley.
- C. If the propeller is in storage in excess of two years, additional inspections are required. Once installed on an aircraft, the propeller calendar limit is not interrupted by subsequent removal and/or storage.
- D. Propeller overhaul should, as much as practical, coincide with engine overhaul. For example, in a case where propeller TBO is 1500 hours and engine TBO is 1400 hours, the propeller should be overhauled at the same time as the engine. This is appropriate as long as neither TBO limit is exceeded.

CAUTION: Review applicable FAA Airworthiness Directives or McCauley Service Bulletins. These may require compliance prior to TBO.

- E. TBO specifications are based on normal aircraft with normal and continuous usage. Flight time and calendar limit must not be the only factors considered in determining when a propeller needs to be overhauled. Factors such as operating conditions or environment often demand that a propeller, governor, or accumulator be overhauled prior to TBO. Even though a propeller, governor, or accumulator may be operating normally and have a good external appearance when the TBO flight time or calendar limit is reached, operation beyond the specified TBO limits is not permitted.
- F. Propeller Models.
- (1) The propeller model designation is impression stamped on the propeller hub. Change letters are frequently stamped at the end of the model designation (e.g. 3A32C406-AD). These letters indicate engineering changes and/or previous overhaul modifications. In Table 1, unless specific change letters are shown, the overhaul frequency note applies to all propellers of that model, regardless of change letters. Use the highest letter stamped after hub model number to determine frequency of overhaul. Refer to Table 601.

McCAULEY PROPELLER SYSTEMS
OWNER/OPERATOR
 INFORMATION MANUAL

Example : Propeller model 3A32C406-AD
 'D' is the highest letter = TBO note T. applies
 Propeller model 3A32C406-B
 'B' is the highest letter = TBO note S. applies

Table 601. Propeller Models

Model Designation	Over-haul Frequency Note	Model Designation	Over-haul Frequency Note	Model Designation	Over-haul Frequency Note
2A34C201-less than C	C.	2A34C201-C or higher	E.	2D34C202	D.
2A34C203-less than C	D.	2A34C203-C or higher	E.	C2A34C204-less than C	D.
C2A34C204-C or higher	E.	B2A34C205	A.	B2D34C206	D.
B2D34C207	D.	B2D34C208	D.	2A34C209-less than C	D.
2A34C209-C or higher	E.	2A34C210	D.	B2D34C211	D.
B2D34C212	D.	B2D34C213	D.	B2D34C214	D.
2D34C215	D.	2A34C216	D.	B2D34C217	D.
B2D34C218	D.	B2D34C219	D.	B2D34C220	D.
2A34C221	D.	2A37C223-less than C	C.	2A37C223-C or higher	E.
B2D37C224	D.	B2A34C225	D.	2A34C227-less than C	D.
2A34C227-C or higher	E.	B2A37C228	A.	B2D37C229	D.
D2A37C230	E.	D2A37C231	E.	2A37C232	E.
E2A37C233	E.	E2A37C234	E.	B2D34C235	E.
C2D37C236	E.	B2A37C238	E.	2A34C239	E.
2A34C240	D.	2A34C241	E.	D2AF34C301	D.
D2AF34C302	D.	D2AF34C303	D.	D2AF34C304	D.
D2AF34C305-less than B	A.	D2AF34C305-B or higher	D.	D2AF34C306	D.
D2AF34C307	D.	D2AF34C308	D.	D2AF34C310	D.
D3A34C401	D.	D3A34C402	D.	D3A34C403	D.
D3A34C404	D.	B3D34C405	D.	3A32C406-less than D	S.
3A32C406-D or higher	T.	B3D32C407	D.	D3A32C408	A.

McCAULEY PROPELLER SYSTEMS
OWNER/OPERATOR
 INFORMATION MANUAL

Table 601. Propeller Models (continued)

Model Designation	Over-haul Frequency Note	Model Designation	Over-haul Frequency Note	Model Designation	Over-haul Frequency Note
D3A32C409-less than D	S.	D3A32C409-D or higher	T.	D3A36C410	D.
D3A32C411	D.	B3D32C412	D.	B3D34C413	D.
B3D32C414	D.	C3D36C415	D.	B3D36C416	D.
B3D32C417	D.	3A32C418	D.	B3D32C419	D.
D3A34C420-less than D	D.	D3A34C420-D or higher	E.	B3D34C421	D.
3A34C422	D.	3A34C423-less than D	D.	3A34C423-D or higher	E.
B3D36C424	D.	B3D36C427	D.	B3D36C428	D.
B3D36C429	D.	D3A36C430	E.	B3D36C431	E.
B3D36C432	E.	B3D36C433	E.	3A36C434	E.
D3A36C435	E.	D3A36C436	E.	B3D36C442	E.
D3A34C443	E.	D3A34C444	E.	D3A34C447	E.
3FF32C501	D.	3AF34C502	D.	3AF34C503	D.
3AF32C504	D.	3AF32C505	D.	3AF32C506	D.
3AF32C507	D.	3AF32C508	D.	3AF32C509	D.
3AF37C510	D.	3AF32C511	D.	3AF32C512	D.
3AF36C514	D.	3AF32C515	D.	3AF37C516	D.
3AF32C521	D.	3AF32C522	D.	3AF32C523	D.
3AF32C524	F.	3AF32C525	D.	B3DF36C526	F.
B3DF36C527	F.	3AF32C528	F.	3FF34C529	V.
3GFR34C601	G.	3GFR34C602	G.	4HFR34C652	H.
4HFR34C653	O.	4HFR34C661	H.	4HFR34C662	H.
4HFR34C663	L.	4HFR34C664	H.	4HFR34C665	K.
3GFR34C701	G.	3GFR34C702	G.	3GFR34C703	I.
3GFR34C704	G.	4HFR34C754	G.	4JFR34C758	G.
4HFR34C762	G.	4HFR34C763	G.	4HFR34C764	H.
4HFR34C766	G.	4HFR34C768	H.	4HFR34C769	H.
4HFR34C771	H.	4HFR34C773	H.	4HFR34C774	G.
4HFR34C775	I.	4HFR34C778	G.	5JFR36C1003	F.
4HFR34C779	H.	B5JFR36C1101	M.	C5JFR36C1102	M.

McCAULEY PROPELLER SYSTEMS
OWNER/OPERATOR
 INFORMATION MANUAL

Table 601. Propeller Models (continued)

Model Designation	Over-haul Frequency Note	Model Designation	Over-haul Frequency Note	Model Designation	Over-haul Frequency Note
5HFR34C1008	H.	C5JFR36C1104	N.	5HFR34C1105	H.
B5JFR36C1103	N.				
Fixed Pitch Propellers	P.	All Propeller Governors	Q.	All Propeller Accumulators	R.

NOTE

- A. 1200 hours or 60 calendar months, whichever occurs first.
- B. 1000 hours or 60 calendar months, whichever occurs first.
- C. 1500 hours or 60 calendar months, whichever occurs first, except:
 - Agricultural aircraft installations - the overhaul frequency is 1200 hours or 60 calendar months, whichever occurs first.
- D. 2000 hours or 72 calendar months, whichever occurs first, except:
 - Agricultural aircraft installations - the overhaul frequency is 1200 hours or 60 calendar months, whichever occurs first.
 - Aerobatic installations - the overhaul frequency is 1000 hours or 72 calendar months, whichever occurs first.
- E. 2400 hours or 72 calendar months, whichever occurs first.
- F. 3000 hours or 72 calendar months, whichever occurs first.
- G. 3500 hours or 72 calendar months, whichever occurs first.
- H. 5000 hours or 72 calendar months, whichever occurs first.
- I. 4000 hours or 72 calendar months, whichever occurs first.
- J. 2000 hours or 72 calendar months, whichever occurs first.
- K. 5000 hours or 72 calendar months, whichever occurs first. 10,000 hour life limit on propeller blades and hub.
- L. 5000 hours or 72 calendar months, whichever occurs first. 16,000 hour life limit on propeller blades.
- M. 6000 hours or 60 calendar months, whichever occurs first.
 - The hub assembly of any B5JFR36C1101 or C5JFR36C1102 propeller that has never operated on a water-methanol assist Jetstream 4100 aircraft -- Replace 6,000 hours.
 - The hub assembly of any B5JFR36C1101 or C5JFR36C1102 propeller that is operating on, or has ever operated on, a water-methanol assist Jetstream 4100 aircraft -- Replace 6000 hours.
 - All 114GCA-0 and L114GCA-0, blades are life limited at 3,500 hours.
- N. 5000 hours or 60 calendar months, whichever occurs first.
 - The hub assembly of any B5JFR36C1103 or C5JFR36C1104 propeller that has never operated on a water-methanol assist Jetstream 4100 aircraft -- Replace 6,000 hours.
 - The hub assembly of any B5JFR36C1103 or C5JFR36C1104 propeller that is operating on, or has ever operated on, a water-methanol assist Jetstream 4100 aircraft -- Replace 6000 hours.
 - All 114HCA-0 and L114HCA-0 propeller blades are life limited at 3,500 hours.

McCAULEY PROPELLER SYSTEMS
OWNER/OPERATOR
INFORMATION MANUAL

- O. *5000 hours or 72 calendar months*, whichever occurs first.
- Agricultural aircraft installations - the overhaul frequency is 2000 hours or 60 calendar months, whichever occurs first.
 - Only for L106FA-0 propeller blades used in the 4HFR34C653 propeller assemblies or blades that have been installed on Jetstream Series 3200 aircraft or history unknown; Propeller blades without change letter "A" must be retired from service before December 1, 2001 or upon reaching 2400 flight hours after August 1, 2000 or 16,000 hours time since new, whichever occurs first. Blades with change letter "A" are life limited to 16,000 hours.
- P. *Fixed pitch propellers - 2000 hours or 72 calendar months which ever occurs first**. Additionally, the propeller mounting bolt torque should be checked at least once per year. Propeller mounting bolts must be magnetic particle inspected in accordance with ASTM E-1444 or liquid penetrant inspected in accordance with ASTM E-1417 or replaced at every overhaul. Propeller mounting bolts must be replaced whenever the propeller is involved in a blade strike as defined in Necessary Actions Following Object Strike of Stationary Propeller, Blade Strike of Rotating Propeller, Bird Strike, or Sudden Engine Stoppage .
- *For 1A170E/JHA[XXXX] propellers only, installed on Aircraft Operating as Pilot Schools in accordance with 14 CFR, Part 141, and all aircraft with 2000 or more cycles for every 1000 flight hours must be inspected in accordance with Service Bulletin 240[X] every 1000 hours or 72 calendar months whichever occurs first.
 - *For 1A103/TCM[XXXX] propellers only, the overhaul frequency is every 1500 hours of operation or 72 calendar months, whichever occurs first. All propellers with 1500 or more hours total time in service must be inspected in accordance with Alert Service Bulletin 221[X] every 750 hours of operation or 36 calendar months whichever occurs first.
- Q. *All Propeller Governors - 2000 hours or 60 calendar months*, whichever occurs first.
- R. *All Propeller Accumulators - 1800 hours or 60 calendar months*, whichever occurs first.
- S. *2000 hours or 72 calendar months, 10,000 hour life limit on blades and hub*, except:
- Aerobatic installations - the overhaul frequency is 1000 hours or 72 calendar months, whichever occurs first. *10,000 hour life limit on blades and hub.*
- T. *2400 hours or 72 calendar months*, whichever occurs first. *10,000 hour life limit on blades and hub*, except:
- Aerobatic installations - the overhaul frequency is 1500 hours or 72 calendar months, whichever occurs first. *10,000 hour life limit on blades and hub.*
- U. For 4HFR34C755 propellers, comply with McCauley Service Bulletin 175, Converting Propeller Model 4HFR34C755 to a 4HFR34C754, then use the overhaul frequency for a 4HFR34C754 propeller.
- V. 3000 hours or 72 calendar months, whichever occurs first, except;
- Agricultural aircraft installations - the overhaul frequency is 1200 hours or 60 calendar months, whichever occurs first.

6. Necessary Actions Following Object Strike of Stationary Propeller, Blade Strike of Rotating Propeller, Bird Strike, or Sudden Engine Stoppage

- A. Propellers with Blades Bent Beyond Repair (Refer to Figure 601).
- (1) A hub must be declared unairworthy and scrapped if any blade in the propeller assembly is bent beyond repair limits within the first 85% of the blade radius.
- B. Object Strike of Stationary Propeller.
- (1) "Object Strike" is defined as any impact of a non-rotating propeller by a substantial moving object, such as any personnel vehicle, aircraft tug, ground power unit, or similar.

NOTE: The definition is intended for use as an example only. Determination as to whether or not an object strike actually occurred is ultimately the responsibility of the aircraft operator.

McCAULEY PROPELLER SYSTEMS
OWNER/OPERATOR
INFORMATION MANUAL

C90

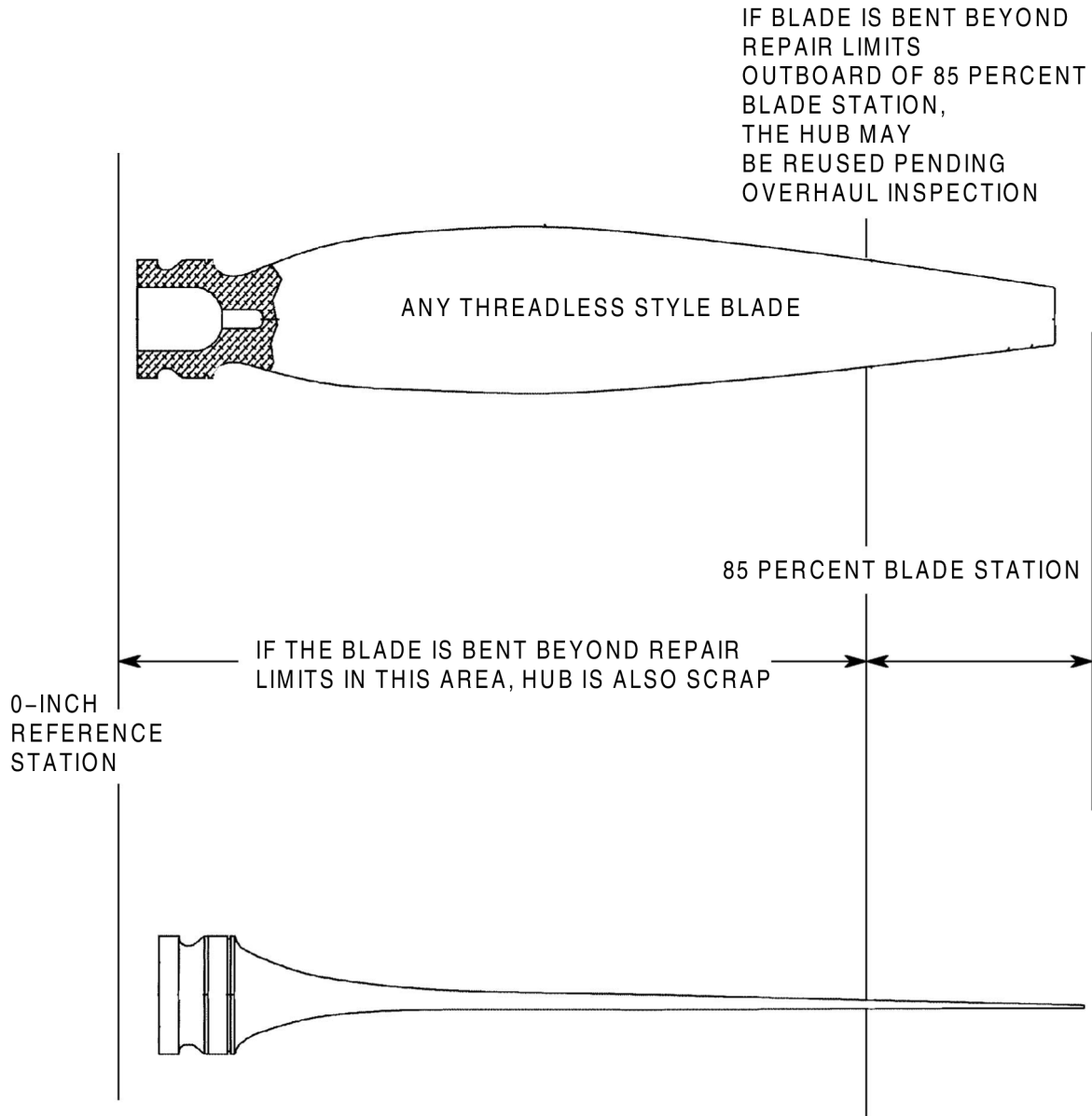

NOTE: THE 85 PERCENT BLADE STATION VALUE IS WITH RESPECT TO THE BASIC DESIGN LENGTH OF A BLADE, NOT THE CUT DOWN LENGTH.

Location of Blade Damage
Figure 601 (Sheet 1)

McCAULEY PROPELLER SYSTEMS
OWNER/OPERATOR
INFORMATION MANUAL

- (2) Inspect all blades for damage such as scrapes, gouges, etc. caused by the impact. Any damage beyond normal field repair limits, refer to Blade Repair for field repair limits, is cause for propeller removal and repair as defined below.
- (3) Check the blade track and verify that all blades measure within the following limits:
 - (a) 0.0625 inch (1.6mm) of each other on piston engine propellers.
 - (b) 0.170 inch (4.3mm) of each other on turbine engine propellers (except propeller models C1101 through C1104).
 - (c) 0.1875 inch (4.7mm) of each other on C1101 through C1104 models.
- (4) Check blade twist. All blades in a propeller should have the same amount of "rotational play". If the difference in rotational play between two blades is beyond 1.0 degree, uneven internal wear or damage is the possible cause.
 - (a) For example, rotational movement of No. 1 blade measures 1.2 degrees and No. 2 blade measures 2.3 degrees. This would be considered excessive since the difference is more than 1.0 degree. This check must be performed every 10 hours for the next 20 hours. If no change is seen after 20 hours, inspections may be discontinued.

NOTE: The results of an object strike inspection should be noted in the propeller log book and, if required, note when the next inspection is due.

- (5) If any propeller blade is damaged beyond field repair limits, the blade track or the propeller blade twist is beyond the limits, contact McCauley for disposition of the propeller assembly.

C. Blade Strike of Rotating Propeller (Refer to Figure 601).

- (1) "Blade Strike", sometimes referred to as "Ground Strike", is defined as any impact or suspected impact of the rotating propeller upon such items as, but not limited to, the ground, tow bars, landing lights, carts, snow banks, hedges, etc. Please note that this definition is intended for use as an example only. Determination as to whether or not a blade strike actually occurred is ultimately the responsibility of the aircraft operator.

CAUTION: Internal damage can occur without evidence of gross external damage.

- (a) Any McCauley propeller experiencing a blade strike must be removed from the aircraft and overhauled by an FAA approved Part 145 Propeller Repair Station or international equivalent in accordance with the applicable overhaul manual. A hub must be declared unairworthy and scrapped if any blade in the propeller assembly is bent beyond repair limits below the 85% station.
- (2) Bird Strike
 - (a) "Bird Strike" can be defined as the impact of any bird into the rotating propeller causing damage.
 - (b) Inspect all blades for damage such as scrapes, gouges, etc. caused by the impact. Any damage beyond normal field repair limits is cause for propeller removal and repair. Refer to Blade Repair for field repair limits.
 - (c) Check the blade track and verify that all blades measure within the following limits:
 - 1 0.0625 inch (1.6mm) of each other on piston engine propellers.
 - 2 0.170 inch (4.3mm) of each other on turbine engine propellers (except propeller models C1101 through C1104).
 - 3 0.1875 inch (4.7mm) of each other on C1101 through C1104 models.
 - (d) Check blade twist. All blades in a propeller should have the same amount of "rotational play". If the difference in rotational play between two blades is beyond 1.0 degree, uneven internal wear or damage is the possible cause.
 - 1 For example, rotational movement of No. 1 blade measures 1.2 degrees and No. 2 blade measures 2.3 degrees. This would be considered excessive since the difference is more than 1.0 degree.

McCAULEY PROPELLER SYSTEMS
OWNER/OPERATOR
INFORMATION MANUAL

- 2 This check must be performed every 10 hours for the next 20 hours after a bird strike. If no change is seen after 20 hours, inspections may be discontinued.

NOTE: The results of a bird strike inspection should be noted in the propeller log book and, if required, note when the next inspection is due.

- (e) If any propeller blade is damaged beyond field repair limits, the blade track or the propeller blade twist is beyond the limits, the propeller must be removed from the airplane and taken to and overhauled by an FAA approved Part 145 Propeller Repair Station or international equivalent.
- (3) Sudden Engine Stoppage
- (a) "Sudden Stoppage" is defined as any propeller experiencing a sudden decrease in RPM. This is commonly due to engine failure or seizure. Please note, determination as to whether or not sudden engine stoppage has occurred is ultimately the responsibility of the aircraft operator. McCauley recommends consulting engine manufacturer's data to determine criteria for sudden engine stoppage.
- (b) Any McCauley propeller experiencing a sudden stoppage must be removed from the aircraft and overhauled by an FAA approved Part 145 Propeller Repair Station or international equivalent in accordance with the applicable propeller overhaul manual.

7. Governors Exposed to Propeller Blade Strike, Propeller/Engine Lightning Strike, Engine Detonation, Oil Contamination, or Sudden Engine Stoppage

A. Compliance: Any governor exposed to propeller blade strike, propeller and/or engine lightning strike, oil contamination, engine detonation, or sudden engine stoppage must not be returned to service as is. It must be repaired or overhauled as defined in Governor Inspection Criteria that follow.

B. Definitions

- (1) "Propeller Blade Strike", sometimes referred to as "Ground Strike", is defined as any impact or suspected impact of the rotating propeller upon such items as, but not limited to, the ground, tow bars, landing lights, carts, snow banks, hedges, etc. Please note that the above definition is intended for use as an example only. Determination as to whether or not a blade strike actually occurred is ultimately the responsibility of the aircraft operator.

CAUTION: Internal damage can occur without evidence of gross external damage.

- (a) Any governor mounted to an aircraft involved in a propeller ground strike must comply with Governor Inspection Criteria.
- (2) Propeller/Engine Lightning Strike: Definition of propeller lightning strike can be found in Lightning Strike Inspection Requirements. Refer to engine manufacturers' service information for definition of engine lightning strike. Any governor showing signs of arcing or pitting due to electrical discharge, mounted on an aircraft exposed to engine or propeller lightning strike as defined in these documents must comply with Governor Inspection Criteria.
- (3) Engine Detonation: Refer to engine manufacturers' service information for determination of engine detonation. Exposure to detonation may impart severe stresses to the governor's rotating parts. Any governor operated under the above conditions must comply with Governor Inspection Criteria.

NOTE: Special attention should be paid to engines exposed to fuel contamination which may have changed the fuel octane rating which could cause engine detonation.

- (4) Engine Oil Contamination: Refer to engine manufacturers' service information for determination of oil contamination. Any governor mounted to an engine which required servicing to remove oil contamination must comply with Governor Inspection Criteria.
- (5) Sudden Engine Stoppage: Refer to engine manufacturer's service information for determination of sudden engine stoppage. Any governor mounted to an aircraft involved in a sudden engine stoppage must comply with Governor Inspection Criteria.

McCAULEY PROPELLER SYSTEMS
OWNER/OPERATOR
INFORMATION MANUAL

C. Governor Inspection Criteria:

- (1) Any governor affected by Compliance above, must perform the following steps:
 - (a) The governor must be tagged that it was involved in such an incident for the information of the overhauling agency.
 - (b) The governor must be overhauled by an authorized McCauley service facility in accordance with McCauley Service Manual 780401.
 - (c) During the overhaul, the service facility must pay particular attention to the following procedures:
 - 1 Perform magnetic particle inspection on flyweight assembly components, idler gear, and drive gear according to instructions in manual.
 - 2 Carefully examine all rotating parts for signs of cracks or other damage.
 - 3 Pay special attention to governor parts involved in a lightning strike. Look closely for signs of burning or metal flow. Any parts showing burns or metal flow must be scrapped and replaced.
 - (d) If parts pass inspection and are found to be acceptable, governor may be reassembled, tested, and returned to service.
 - (e) If parts do not pass inspection, replace damaged parts before governor is reassembled, tested, and returned to service.
 - (f) Record a clear entry in the appropriate airframe and/or engine logbook indicating inspection/repair of the governor per this manual.

8. Blade Track Check

A. Check.

- (1) Turn propeller so that Number 1 blade is straight down.
- (2) Position a smooth board beneath the blade tip.
- (3) Block up the board firmly in place just clear of the blade tip.
- (4) Place a pencil mark approximately 1.0 inch (25 mm) long on the board at the midpoint of the outer edge of Number 1 blade tip.
- (5) Turn the propeller so next blade is straight down.
- (6) Place a thin 1.0 inch (25 mm) line on the board at the midpoint of the outer edge of the second blade tip.
- (7) Carefully turn propeller, and repeat tracking measurement for each blade.
- (8) Each time a line is added, measure the horizontal difference between the lines farthest apart.
 - (a) For propellers installed on piston engines, all blades must measure within 0.0625 inch (1.6 mm) of each other.
 - (b) For C1101 through C1104 models propellers installed on turbine engines, all blades must measure within 0.1875 inch (4.7 mm) of each other.
 - (c) For all propellers installed on turbine engines except C1101 through C1104 model propellers, all blades must measure within 0.170 inch (4.3 mm) of each other.
- (9) If blade track difference exceeds the allowable limits, remove the propeller and have the propeller face alignment checked by an authorized McCauley service facility.

9. Lightning Strike Inspection Requirements

A. If doubt exists as to the occurrence of a lightning strike, the following criteria can be used to verify any suspicion:

- (1) Check for burns or signs of arcing on blades and hub.
- (2) Using a magnetism detector, check all exposed steel areas of propeller for magnetism. A positive magnetic indication suggests the propeller was struck by lightning.

NOTE: Any accepted industry standard magnetic detection device is permitted to be used to test for magnetism in the exposed steel parts of the propeller.

- (3) Look for any signs of localized melting or metal flow, particularly on blades.
- (4) If preliminary inspection suggests an actual strike, a complete propeller overhaul is to be accomplished in accordance with the applicable McCauley overhaul manual by an authorized McCauley overhaul facility.

McCAULEY PROPELLER SYSTEMS
OWNER/OPERATOR
 INFORMATION MANUAL

10. Propeller Overspeed Inspection Requirements

A. The following are inspection criteria for McCauley propellers involved in an overspeed condition.

	Percentage Overspeed	Action to be Taken
All Propellers on Reciprocating Engines	Up to, but not including 15%	General external visual inspection. No further action required.
	15% or Higher	Contact McCauley Product Support for disposition.
All Propellers on Turbine Engines except C1101, C1102, C1103, and C1104	Up to, but not including 10%	General external visual inspection. No further action required.
	10% or Higher	Contact McCauley Product Support for disposition.
C1101, C1102, C1103, and C1104	Up to, and including 6 percent	Up to 5 minutes operation is permitted. Operation beyond 5 minutes may require some inspection. Contact McCauley Product Support for disposition.
	Above 6 percent	Teardown inspection is required. This inspection can only be accomplished by an authorized McCauley service facility. Record all details of the overspeed event and contact McCauley Product Support for disposition.

11. Propeller Overtorque Inspection Requirements

A. The following are inspection criteria for McCauley model C1101, C1102, C1103, and C1104 propellers involved in an overtorque condition.

NOTE: This overtorque limitation/inspection only applies to model C1101 thru C1104 propellers. For all other McCauley turbine propellers that have experienced an overtorque condition, contact McCauley Product Support for propeller disposition.

- (1) Engine Overtorque up to and including 101 percent - maximum continuous operation permitted.
- (2) Engine overtorque of between 102 percent to 110 percent is permissible for up to 30 seconds duration, provided no condition in section 3 also occurs.
- (3) McCauley should be contacted and given exact operating conditions for determination of corrective action for engine overtorque during one or more of the following conditions:
 - (a) 111 percent torque or higher.
 - (b) Overtorque during ground operations.
 - (c) In-flight overtorque of between 102 percent and 110 percent for more than 30 seconds
 - (d) Overtorque of between 102 percent and 110 percent for less than 30 seconds under the following:
 - 1 Banked turns of more than 45 degrees.
 - 2 Yaw of more than or equal to 2/3 ball as indicated by the airplane turn and bank indicator or similar instrument.
 - (e) Any overtorque condition outside the above criteria.

McCAULEY PROPELLER SYSTEMS
OWNER/OPERATOR
INFORMATION MANUAL

12. Normal Criteria for Static Blade Shake and Twist of All Variable Pitch Propellers

- A. **BLADE SHAKE:** Blade shake is defined as follows (Refer to Figure 602):
- (1) The tendency for the propeller blades to wobble slightly when the tip is physically moved by hand (leading edge to trailing edge) is known as blade shake.
 - (a) This tendency is a natural result of the fabrication of parts within the McCauley retention system. While accumulation of tolerances is measured in thousandths of an inch, it must be remembered that both the parts causing blade shake, and the pivot point about which the blade rotates, are near the blade root. As a result, very small differences at the blade root will be magnified many times when measured at the tip.
 - 1 Total maximum allowable movement up to 0.125 inch (3.13 mm) is considered normal.
 - 2 C1100 series propellers may have a maximum movement of 0.1875 inch (4.7 mm).
 - (2) Normal blade shake (less than maximum allowable movement) is no cause for concern, as it disappears during propeller rotation due to the high centrifugal forces acting on the blades (20,000 to 45,000 pounds. (89,000 to 200,000 N)).
 - (a) If blade shake exceeds maximum movement allowable, it should be reduced, when convenient, by inserting shims in the blade assembly by an authorized McCauley overhaul facility.
- B. **BLADE TWIST:** Two Categories of Blade Twist exist. They are defined as follows (Refer to Figure 602):
- (1) Rotational play is defined as the sum total of rotational movement a propeller blade allows when moved by hand around its axis of rotation.
 - (a) This movement is, to a limited degree, considered normal and should not be cause for concern. All blades in a propeller should have about the same amount of rotational play.
 - (b) If the difference in rotational play between two blades is beyond 1.0 degree, uneven internal wear and/or damage is the possible cause.

EXAMPLE: Rotational movement of No. 1 blade measures 1.2 degrees, and No. 2 blade measures 2.3 degrees. This would be considered excessive since their difference is beyond 1.0 degree.
 - (c) The cause of the excessive difference should be determined by an FAA approved Part 145 Propeller Repair Station or international equivalent at the next opportunity.
 - (2) Blade angle split is a measurement of the angle differences between all the blades in the same propeller. This value is much more critical than rotational play described above, as a high blade angle split may indicate internal problems. While such angle split is very rare, the operator may want to measure it if a problem is suspected, most notably by a marked increase in propeller vibration levels. Blade angle split may be checked as follows:
 - (a) By hand, twist all feathering blades toward high pitch. By hand, twist all non-feathering blades toward low pitch. This will eliminate any play in the propeller linkage, and reduce the possibility of a false angle reading.
 - (b) Using a propeller protractor at the appropriate reference station, measure the angle of each blade.
 - 1 If measurements differ greatly (more than 0.5 degrees) between blades on the same propeller, excessive wear or damage to internal parts may exist.
 - 2 If the blade angle split is in excess of 0.5 degrees, the propeller must be overhauled at an FAA approved propeller service station or international equivalent at the next opportunity.

13. Engine Oil Contamination Inspection Requirements

- A. Any propeller exposed to engine oil contamination must be removed and sent to an FAA approved Part 145 Propeller Repair Station or international equivalent for inspection. Refer to the service information of the engine manufacturer to determine if oil contamination has occurred or to determine the acceptable amount of metal particles allowed in engine oil.

McCAULEY PROPELLER SYSTEMS
OWNER/OPERATOR
INFORMATION MANUAL

C89

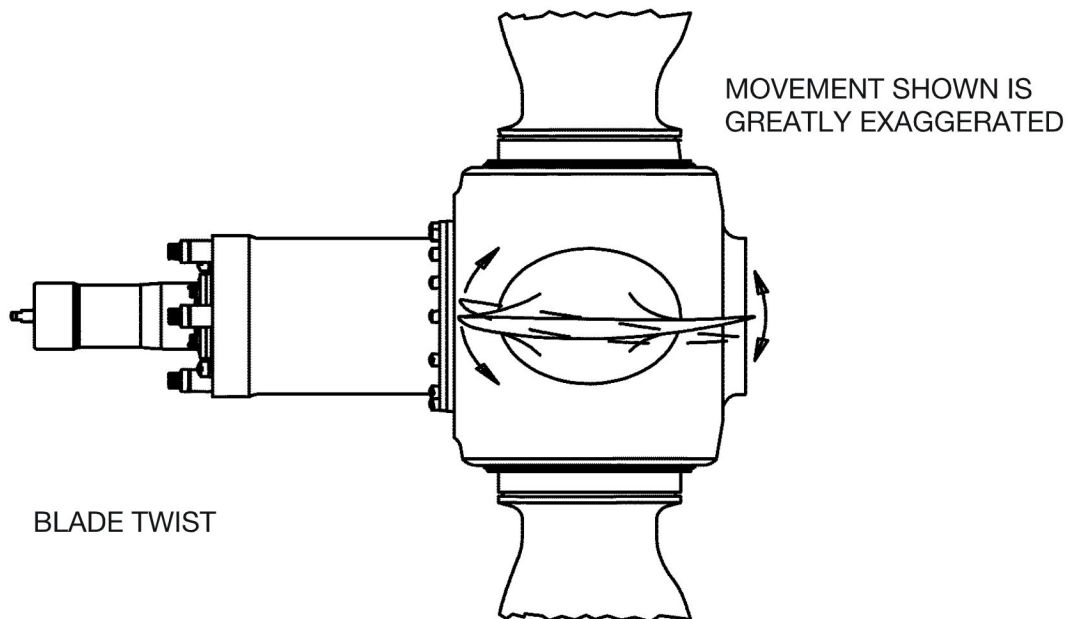
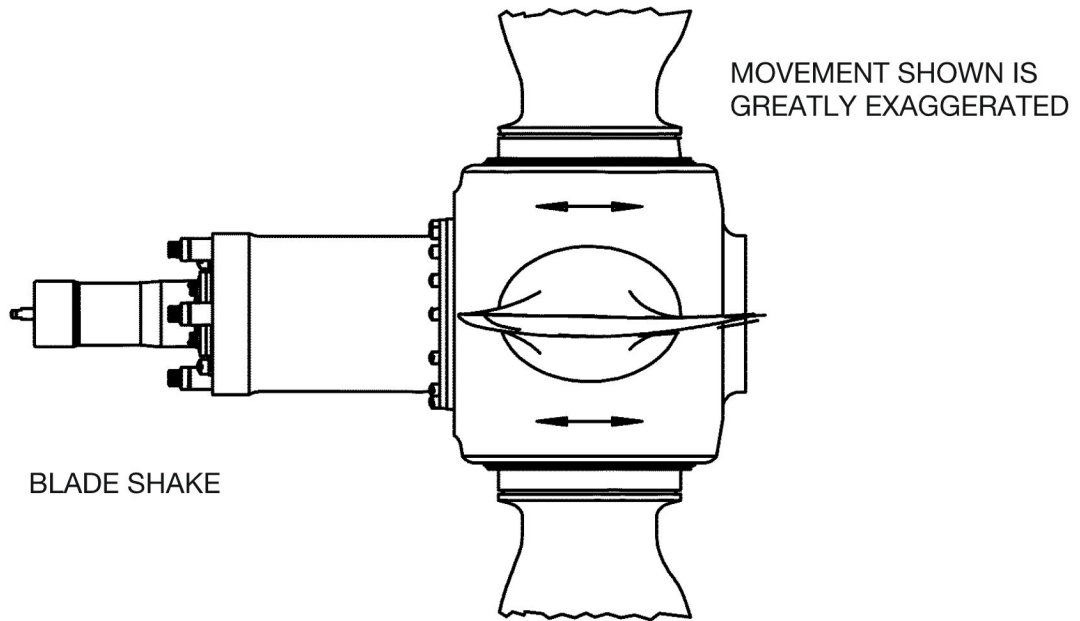

Blade Shake and Blade Twist
Figure 602 (Sheet 1)

McCAULEY PROPELLER SYSTEMS
OWNER/OPERATOR
INFORMATION MANUAL

14. Fire Inspection

- A. Any propeller or governor exposed to fire or excessive heat is considered unairworthy and must be removed from service and scrapped. A propeller is considered exposed to fire or excessive heat if after the suspected exposure it shows any of the following conditions:
- (1) Bubbled paint.
 - (2) Discolored paint.
 - (3) Discolored metal.
 - (4) Melted areas.

15. Non-Destructive Inspection Procedures

- A. Fluorescent Dye Penetrant Inspection.
- (1) General.
 - (a) Fluorescent dye penetrant inspection shall be performed as specified in this manual on products manufactured by McCauley Propeller Systems. Penetrant inspection, for continued airworthiness, shall be used to detect cracks or discontinuities open to the surface which may not be evident by direct visual inspection.

WARNING: Some of the chemicals used in a fluorescent dye penetrant inspection can be harmful to the skin and eyes. The manufacturer's safety precautions must be obeyed when handling fluorescent dye penetrant inspection materials.

- (b) Inspection is performed in accordance with standard ASTM-E-1417 (latest revision), Standard Practice for Liquid Penetrant Examination. McCauley requires all dye penetrant inspections to conform to the Type I Fluorescent Dye and with a sensitivity level 3 as described in the ASTM-E-1417 (latest revision) standard.

NOTE: The use of visible dye penetrants (Type II) is not recommended for the inspection of the propeller and propeller hardware. While Type II visible dye penetrants do have limited crack detection capability, the constituents of visible dye penetrants are likely to deposit residue in crack voids. The residue can be extremely difficult to remove from cracks, regardless of the cleaning method employed. Cracks can become fully or partially masked by the remaining residue. Due to these characteristics, visible dye penetrants can make follow-on detection of existing cracks virtually impossible when using other NDI penetrant methods, specifically Fluorescent Penetrant Inspection (FPI). Use of FPI for NDI type inspections on some propellers and propeller hardware is a requirement at propeller overhaul. Furthermore, visible dye residue contamination of fluorescent penetrant fluid is also known to significantly reduce the brightness of fluorescent indication. Visible dye penetrants include AMS2644, Type 2 red dye penetrant, or any vividly colored dye penetrant visible under ordinary white light. AMS2644, Type 1, Fluorescent penetrants which are visible under ultraviolet light are considered different materials by standard practices and should not be considered a subset of visible dye penetrants.

- (2) Personnel.
 - (a) Individuals performing inspections for continued airworthiness defined in this manual shall hold an Airframe and Powerplant rating or international equivalent or the inspection is conducted at an FAA approved Part 145 Repair Station or international equivalent.
- (3) Acceptance Criteria.
 - (a) Any verified flaw indications are rejectable.
 - (b) Any indication which is believed to be non-relevant shall be regarded as a defect and shall be reexamined by a McCauley authorized propeller service facility to verify whether or not actual defects are present.

McCAULEY PROPELLER SYSTEMS
OWNER/OPERATOR
INFORMATION MANUAL

- (4) Post Cleaning.
 - (a) Residual penetrant and developer must be removed prior to recoating using a cleaning solvent or vapor degreasing (refer to Cleaning/Painting/Protective Treatments). Verify complete removal by inspecting under an ultraviolet light.

McCAULEY PROPELLER SYSTEMS
OWNER/OPERATOR
INFORMATION MANUAL

CLEANING/PAINTING/PROTECTIVE TREATMENTS

1. General

A. Cleaning Procedures

CAUTION: Do not clean any McCauley propeller part with a steel brush, other metal brush, hard bristle brush, or tool of any type not specified.

CAUTION: As applicable during cleaning procedures, observe allowable dimension limits established for certain parts.

- (1) Remove dirt, paint (when applicable), grease and oil from all disassembled metal parts of propeller.
- (2) Use McCauley approved cleaning mediums only (Refer to Table 701).
- (3) Clean all small, highly finished parts separately.
 - (a) Be careful not to damage small metallic parts, especially on working faces.
 - (b) Clean nonmetallic parts (except gaskets, packings, and seals) by wiping with a soft, lint-free cloth dampened with an approved cleaning medium.
 - (c) Remove thick or packed-on grease or dirt with a soft brush.
 - (d) Allow cleaned parts to air dry.

NOTE: Remove excess moisture with a gentle stream of clean, dry compressed air keeping nozzle of air hose well away from parts.

- (4) Protect cleaned parts from collecting dust and dirt during storage or during handling at overhaul.

NOTE: Keep small parts in transparent plastic bags.

2. Consumable Material

A. General

- (1) This section contains information on materials commonly used for cleaning, repair, rework, painting, etc.
- (2) Contact McCauley Propeller Systems for approval to use materials not included on these lists.

WARNING: Some of the chemicals used for cleaning, painting or for applying a protective treatment can be harmful to the skin and eyes. The manufacturer's safety precautions must be obeyed when handling cleaning, painting or protective treatment materials.

B. Material Control Requirements

- (1) Materials purchased from McCauley Propeller Systems will be labeled with an expiration date control information required by McCauley in a different location from the manufacturer's label. McCauley control information takes precedence should there be any conflicting information with the manufacturer's information.
- (2) For materials purchased from other sources, the purchaser is required to record the expiration date control information on the package.

C. Date Code Formats

- (1) Expiration date may be recorded using the letters "exp" followed by a month and year. In this case, the shelf life of that material extends through the last day of the month and year recorded.
- (2) Cure date for elastomeric products such as O-rings, gaskets, and hoses is normally recorded on the packaging using the numbers 1-4, the letter "Q," and the last two numbers of the year. This marking indicates that the material was cured during a particular "quarter" (i.e. three month period) of the stated year. For example, 1Q92 indicates a cure date of the first quarter of 1992.
- (3) Cure date marking will suffice for control purposes. The actual date of expiration will occur after the last day of the quarter in the year projected from the cure date plus the allowable number of years for storage.

McCAULEY PROPELLER SYSTEMS
OWNER/OPERATOR
 INFORMATION MANUAL

- D. Consumable Material Management Procedures
- (1) Rotate stock on a first in-first out basis.
 - (2) Epoxy and other materials normally require, at minimum, a room temperature cure. Lower temperatures may greatly increase the cure time. Temperatures below 60° F (16° C) may cause the epoxy to not cure at all.
 - (3) The maximum storage time for O-rings and gaskets:
 - (a) All O-rings must adhere to the storage guidelines set forth in the SAE ARP 5316.
 - (b) All gaskets the maximum storage life is 15 years from the date of cure.
 - (4) Deice Boots.
 - (a) Deice boots do not have a shelf life if stored in accordance with the manufacturer's instructions.
 - (5) Lubricants
 - (a) Table 701. provides a listing of lubricants approved for use in McCauley products.

Table 701. Lubricants

Part Number	Description	Manufacturer	Notes
A-1637-4	Orelube K-2	Orelube Corp. 201 E. Bethpage Rd. Plainview, NY 11803 Phone: 516-249-6500	Molybdenum disulfide non-melt grease
A-1637-11	Dyed Oil (Piston engines)		1 gallon of Aeroshell Oil W65 and 12 grams of A-4880-1
A-1637-13	Aeroshell Oil W65 (Recommended)	Shell Oil Company P.O. Box 659501 Houston, TX 78265-9501	Any SAE 10W or 10W multi-grade piston engine oil is acceptable.
A-1637-14	Turbine Oil BP Turbo Oil 2380	Air Bp Lubricants 6 Campus Drive Parsippany, NJ 07054 Phone: 973-401-4350 Fax: 973-401-4355, Web: www.airbp.com	Turbine oil conforming to MIL-PRF-23699. NOTE: Field technicians may not combine different turbine oils.
A-1637-16	Grease MIL-T-83483	Convoy Oil Corp. 1412 Front street Philadelphia, PA 19122 Phone: 215-739-5281 Fax: 215-739-6933	
A-1637-18	Dyed Oil (Turbine engines)		1 gallon of BP Turbo Oil 2380 and 12 grams of A-4880-1
A-4880-1	Red "B" liquid dye		NOTE: A-4880-1 red "B" liquid dye does not have a shelf life
	LPS-3 Heavy duty Rust Inhibitor	LPS Laboratories 7647 Hugh Howell Road Tucker, GA USA 30085-9206 Fax: 770-493-9206	In corrosive environments, spray on blade retaining snap ring and area to prevent corrosion of the retaining rings.

- (6) Adhesives and Sealants
 - (a) Table 702. provides a listing of sealants approved for use in McCauley products.

McCAULEY PROPELLER SYSTEMS
OWNER/OPERATOR
 INFORMATION MANUAL

Table 702. Adhesives and Sealants

Part Number	Description	Manufacturer	Notes
A-1664-15	Scotch-Grip Brand Rubber Adhesive #1300L	3M Company Bldg. 209 2S 31 3M Center St. Paul, MN 55144 Phone: 651-733-9288 Fax: 651-736-8336	
A-1664-16	De-icer Conductive Cement #A-56-B	Sovereign Specialty Chemicals SIA Adhesives, Inc 123 W. Bartges Street Akron, OH 44311-1081 Phone: 330-374-2900 Fax: 314-771-1858	
A-1664-17	82-076 De-ice Boot Edge Sealer Kit	BFGoodrich De-Icing and Specialty Systems 1555 Corporate Woods Pkwy. Uniontown, OH 44685 Phone: 800-334-2377	Equivalent to Sterling Lacquer's system
A-1664-17	De-ice Boot Edge Sealer F63B12	Sherwin-Williams 101 Prospect Ave N. W. Cleveland, OH 44115 Phone: 216-566-2902	Mix eight parts sealer to one part accelerator.
A-1664-17	De-ice Boot Edge Sealer 78-A-1003	Sterling Lacquer Mfg. Co. 3160 Brannon Ave. St. Louis, MO 63139 Phone: 314-776-4450 Fax: 314-771-1858	Mix two parts (A-1664-17) with one part (A-1664-18).
A-1664-17	MAT500 Edge Seal	Indestructable Paint, LTD.. 16-25 Pentos Dr. Birmingham, United Kingdom B11 3TA Phone: +44-121-720-9475	Equivalent to Sterling Lacquer's system
	Bostick 1096M Adhesive	Bostik Findley, Inc. 211 Boston Street Middleton, MA 01949-2128 Phone: 978-777-0100, <u>Web:</u> www.bostik.com	
	Bostick 1008 Cement	Bostik Findley, Inc	

(7) Paint and Protective Finish

(a) Table 703. provides a listing of recommended paints, primers and finish materials for use on McCauley products.

McCAULEY PROPELLER SYSTEMS
OWNER/OPERATOR
 INFORMATION MANUAL

Table 703. Paint and Protective Finish

Part Number	Description	Manufacturer	Notes
P60G2	Wash primer	Sherwin-Williams 591 Somerset Tr NE Atlanta, GA 30306 Phone: (404) 885-5510	P60G2 Wash primer to be mixed with R7K44 Reducer
P60G2	Reducer	Sherwin-Williams	P60G2 Wash primer to be mixed with R7K44 Reducer
	E90Y302 Zinc Chromate Primer MIL-P-8585	Sherwin-Williams	NOTE: This primer has also been identified as Pratt & Lambert Product Number - 723-400, Cessna RMPN - K000440 Specification Certification - TT-P-1757, Rev.B, Type I, Class C, Color Y
F563TXB114 92-4302	Flat Black	Sherwin-Williams	Polane-T Topcoat
F63TXW114 45-4302	White	Sherwin-Williams	Polane-T Topcoat
F63TXA1158 2-4302	Gray	Sherwin-Williams	Polane-T Topcoat
F63TXR1134 7-4302	Red	Sherwin-Williams	Polane-T Topcoat
F63TXS1443 3-4302	Silver	Sherwin-Williams	Polane-T Topcoat
F63TXW159 26-4302	Matterhorn Weight	Sherwin-Williams	Polane-T Topcoat
V66V27	Catalyst	Sherwin-Williams	Polane-B Base Component
R7K84	Thinner	Sherwin-Williams	Polane-B Base Component
F63B13	Static Black, Hi Gloss	Sherwin-Williams	Polane-B Topcoat
F63BXH120 27	Cirrus Linen White/Beige	Sherwin-Williams	Polane-B Topcoat
	Turcoat Liquid Accelagold		
	Alodine 1200s	Henkel Surface Technologies 32100 Stephenson Highway Madison Heights, MI 19020 Phone: 248-583-9300	
	Alodine 1201	Henkel Surface Technologies	
	207 High Temperature Aluminum Enamel	Plastic-Kote 1000 Lake Rd. Medina, OH 44256 Phone: 330-725-4511	

McCAULEY PROPELLER SYSTEMS
OWNER/OPERATOR
 INFORMATION MANUAL

Table 703. Paint and Protective Finish (continued)

Part Number	Description	Manufacturer	Notes
	#DE-1615 High Temperature Aluminum Enamel	Sherwin-Williams Dupli-Color Product Group	
	Chemical Stripper MIL-R-81294 Type II QPL-81294-26		
	Turco Transpo Paint remover	Henkel Surface Technologies	
	Polane Paint Remover IDS-12D-LT	DeBois Chemical Company	

(8) Cleaners and Solvents

(a) Table 704. provides a listing of approved cleaners and solvents for use on McCauley products.

Table 704. Cleaners and Solvents

Part Number	Description	Manufacturer	Notes
	MPK (methyl propyl ketone)		
	Toluene		approved substitute for MPK
	Oil based Solvent Mixture: One part lubrication oil MIL-L-6082 Grade 10-30 and two parts MIL-PRF-680 Type II (Stoddard Solvent)		
	Mineral spirits MIL-PRF-680, Type. I, II, or III		
	Isopropyl Alcohol T-T-735		
	Perchlorethane		
	Paint Remover MIL-R-81294		
	Lacquer Thinner		
	Acetone		

(9) Miscellaneous Material

(a) Table 705. provides a listing of recommended miscellaneous materials for use on McCauley products.

McCAULEY PROPELLER SYSTEMS
OWNER/OPERATOR
 INFORMATION MANUAL

Table 705. Various

Part Number	Description	Manufacturer	Notes
	Self-Adhesive Polyurethane Tape 8671	3M Company 3M Center St. Paul, MN 55144 Phone: 800-362-3550 Fax: 651-736-8336, <u>Web:</u> www.3m.com	
	Non-Etch Alkaline Cleaner NE-7 Cleaner	Enthone/Crookston Electronics 350 Frontage Rd. West Haven, CT 06516 Phone: 203-934-8611	
	Hypodermic syringe, 15 cc with 20- and 24-gauge needles		
	masking tape, 0.25 inch (6.35 mm), 0.5 inch (12.7 mm), 1.0 inch (25.4 mm), 2.0 inch (50.8 mm)		
	cotton swab		Medical or Cosmetic Grade, Non-sterilized
	cotton ball		Medical or Cosmetic Grade, Non-sterilized
	clean, dry, lint-free cloths		
	Abrasive paper 220, 300, 400, and 600 grit wet/dry		
	ScotchBrite (alternative to sandpaper) medium, coarse, fine		
	Safety wire (NASM20995C20, NASM20995C32, NASM20995C41)		
	Syringe, 1.5 cc hypodermic with 20- and 24-gauge needles		

McCAULEY PROPELLER SYSTEMS
OWNER/OPERATOR
 INFORMATION MANUAL

3. Pre-Cleaning Procedures

Table 706. Approved Solvent and Cleaning Medium Applications

Medium	Application
Stoddard Solvent Type II MIL-PRF-680	to clean any metal surface
Methyl-propyl-ketone (MPK) or Acetone or equivalent	to clean metal surface prior to application of sealant
	to soften adhesion line between deice boot and blade
	to clean slip ring assembly
	to remove residual deice boot cement from blade
Perchloroethane	to clean aluminum part prior to dye penetrant inspection
Paint Remover MIL-R-81294	to loosen and remove paint and grease
Lacquer Thinner	to loosen grease on hub
	to loosen/remove general adhesives and sealants
	to loosen and remove decals

4. Blade Cleaning

- A. Clean blade surfaces with a nonmetallic brush and/or plastic rubber scraper.
- B. Thoroughly rinse cleaned blades with tap water and a soft brush.

5. Propeller Protective Treatments

- A. Cadmium Plating
 - (1) Parts that require Cadmium plating shall be taken to an FAA approved Part 145 Propeller Repair Station or international equivalent for disposition and plating.
- B. Cadmium Alternatives: Phosphate Treatment and Zinc-Nickel Plating
 - (1) Parts that require phosphate treatment or zinc-nickel plating shall be taken to an FAA approved Part 145 Propeller Repair Station or international equivalent for disposition and plating.
- C. Nickel Plating
 - (1) Parts that require Nickel plating shall be taken to an FAA approved Part 145 Propeller Repair Station or international equivalent for disposition and plating.
- D. Thermal Black Oxide Plating
 - (1) Parts that require Thermal Black Oxide plating shall be taken to an FAA approved Part 145 Propeller Repair Station or international equivalent for disposition and plating.
- E. Chrome Plating
 - (1) Parts that require Chrome plating shall be taken to an FAA approved Part 145 Propeller Repair Station or international equivalent for disposition and plating.
- F. Anodize

NOTE: All repaired and overhauled hubs and all repaired blades must be anodized or have Chemical Conversion Film Coating applied for corrosion protection.

- (1) Parts that require to be anodized shall be taken to an FAA approved Part 145 Propeller Repair Station or international equivalent for disposition and to be anodized.

McCAULEY PROPELLER SYSTEMS
OWNER/OPERATOR
INFORMATION MANUAL

G. Chemical Conversion Film Coating

NOTE: All repaired hubs and all repaired blades must be anodized or have Chemical Conversion Film Coating applied for corrosion protection.

- (1) General
 - (a) The process for aluminum components must be in accordance with MIL-DTL-5541 and MIL-DTL-81706 Class 1A.
 - (b) All repairs must be complete before the part is treated.
 - (c) All grease, oil, or other material must be removed using solvent and/or a water based cleaner so the part, or the area of the part to be treated, has a water break free surface as required by section 3.3.2 of MIL-DTL-5541.
- (2) All parts that are chemical conversion film coated must have paint applied except on the engine mounting flange, cylinder mounting flange, and the area of the hub socket where the shim carrier contacts the hub.

CAUTION: Paint or primer is not allowed on the engine mounting flange, cylinder mounting flange, and the area of the hub socket where the shim carrier contacts the hub. This is a 5.295 inch (134.5 mm) diameter circle measured from the center of all blade sockets. Paint and primer are not allowed inside of hub socket on threadless propellers.

H. Corrosion Protection

- (1) For propellers that operate in salt air or other corrosive environments:
 - (a) Apply LPS-3 around the blade retaining rings and shim carrier.

6. Blade Painting

NOTE: McCauley strongly recommends that all blades be painted. Paint and primer protect blades from corrosion. McCauley recommends Sherwin-Williams products, but any industry equivalent is acceptable. The following procedure is recommended, but any procedure achieving similar results is acceptable.

NOTE: Repainting the entire propeller blade or the propeller assembly should only be accomplished at an FAA approved Part 145 Propeller Repair Station or international equivalent. Without the proper training and equipment, the static balance of the propeller can be affected by the application of paint.

NOTE: The propeller face side should be painted flat black unless otherwise noted.

A. Paint and Primer Mixtures.

NOTE: McCauley recommends Sherwin-Williams products, but any industry equivalent is acceptable. The following list of paints are recommended, but any equivalent paint that will achieve similar results is acceptable.

NOTE: All drying times are based on 77° F (25° C) and 45% relative humidity.

CAUTION: No paint or primer is allowed in blade retention area or the counterweight surface.

- (1) Primer should be tack free in 10 to 20 minutes and can be recoated in 30 to 60 minutes.
- (2) Allow for different drying times at different temperatures and humidity levels.

McCAULEY PROPELLER SYSTEMS
OWNER/OPERATOR
 INFORMATION MANUAL

Table 707. Paint and Primer Mixtures

Paint/Primer	Mixture Instructions
Primer	1 Part Sherwin Williams P60G2 Industrial Wash Primer to 1.5 parts Sherwin Williams R7K44 Activator/Thinner
Semi-Flat Black Paint F63TXB11492	Mix as directed by the manufacturer with V66V27 catalyst and R7K84 reducer (Note 1) Federal Standard 595 Color 37038
Semi-Flat White Paint F63TXV11445	Mix as directed by the manufacturer with V66V27 catalyst and R7K84 reducer (Note 1) Federal Standard 595 Color 17875
Semi-Flat Silver Paint F63TXS14433-4302	Mix as directed by the manufacturer with V66V27 catalyst and R7K84 reducer (Note 1)
Semi-Flat Gray Paint F63YXA11582	Mix as directed by the manufacturer with V66V27 catalyst and R7K84 reducer (Note 1)
Gloss Yellow Paint F63BXY11719	Mix as directed by the manufacturer with V66V27 catalyst and R7K84 reducer (Note 1)
Semi-Flat Red Paint F63TXR11347	Mix as directed by the manufacturer with V66V27 catalyst and R7K84 reducer (Note 1) Federal Standard 595 Color 31136

NOTE 1: The color numbers are assigned by the Atlanta, Georgia Sherwin-Williams facility.

- B. The painted surface must be recoated with the first coat of the finish enamel within four hours of application of the primer.
- C. Apply the paint in accordance with the manufacturer's instructions.

NOTE: Overnight drying time is recommended after paint application.

- D. The recommended dry film paint thickness on constant speed and full feathering propeller blades should be 3 mils thick, and on turbine propellers 6 mils thick.

NOTE: Tip stripes should be painted on the camber side only so as not to interfere with the pilot's field of vision. Some propellers installed in a pusher configuration (and out of the pilot's field of view) may have a different paint scheme for the propeller blade tips.

- E. On turbine propellers only, make sure there is a 2 inch (51 mm) long by 0.070 inch (1.8 mm) wide yellow or white line at the 30 inch (762 mm) station (except for the paint scheme that is used on C1101, C1102, C1103, and C1104 model propellers which places the line at the 42 inch (107 mm) station). This line indicates the blade angle reference station. Center the line between the trailing and leading edges. When requested by the owner of a fleet, this line may be left off or painted a specific color.
- F. Special Instructions for Fixed Pitch Propellers:
 - (1) Do not paint flat, engine mating surface side of the propeller hub.
- G. Special Instructions for C1103 and C1104 model Propellers (Figure 702):
 - (1) Make sure the thin dashed yellow lines at the 26 inch (660 mm) station on both the face and camber sides of the blade are maintained and easily visible. This marks the end of the shotpeen region of the blade. (refer to Figure 702).

7. Spinner Chrome Plating

- A. McCauley does not approve the chrome plating of McCauley propeller spinners. Field experience has shown that chrome plated spinners often peel after a short time in service. Strong evidence also exists that chrome plating can lead to spinner fatigue cracking, thus scrapping the spinner shell. Chrome plating will void the McCauley warranty.

McCAULEY PROPELLER SYSTEMS
OWNER/OPERATOR
INFORMATION MANUAL

PROPELLER APPROVED REPAIRS

1. Blade Repair

A. Removal of Blade Damage

(1) General

- (a) The propeller blade is a highly stressed part. The fact that propeller blades are subject to impact damage, (such as nicks, gouges, and scratches), and corrosion, (primarily uniform etch and pitting corrosion, but intergranular or exfoliation type corrosion can also occur) demands frequent inspection and maintenance.
- (b) Repair of small nicks, gouges and scratches that do not exceed the damage specifications identified in this section, Blade Repair are considered "Minor Repairs" and may be performed by an appropriated rated mechanic or repair station. After filing and polishing, the damaged area should be inspected, and when possible, by fluorescent dye penetrant method to verify that all damage has been removed and the blade is not cracked. The area should then be re-protected by localized application of chemical film per MIL-C-5541 (for example, Alodine) and repainted as necessary.

NOTE: Refer to the Non-Destructive Inspection Procedures for fluorescent dye penetrant inspection procedures.

NOTE: If it is not possible to inspect the repaired area using the fluorescent dye penetrant inspection method, the repaired region should be inspected with a minimum 10x power lens to ensure any sharp notches or cracks have been removed.

- (c) All other damage that exceeds the damage specifications identified in this section, Blade Repair, or other damage such as bent blades, are considered "Major Repairs" and must be corrected by a McCauley authorized service facility and are not field repairable.

(2) Damage Specifications

- (a) The depth of damage must be measured using a depth gage.
- (b) Damage that is located on the leading or trailing edges must not exceed 0.094 inch (2.39 mm) in depth.
- (c) Damage that is located on a repairable area of the face or camber side of the blade must not exceed 0.061 inch (1.55 mm) in depth.
 - 1 For controllable pitch propellers:
 - a Impact and corrosion damage that is located at least 6.0 inches (152 mm) from the hub socket is in an area that is field repairable.
 - 2 For fixed pitch propellers:
 - a Impact and corrosion damage that is located at least 12.0 inches (305 mm) from the center of the propeller mounting flange is in an area that is field repairable.
- (d) Damage that is located outside the field repairable area or damage depth greater than these limits is not field repairable. An FAA approved Part 145 Propeller Repair Station or international equivalent may be able to do a repair. Contact McCauley Product Support for disposition of any damage that is deeper than the specified limits.

(3) Repairable Damage

- (a) The primary type of blade damage that a mechanic need be concerned with is sharp stress riser type damage. This type of damage is caused by stones or other small objects striking the propeller blade as it rotates. Erosion caused by sand, water, etc. that does not create sharp stress riser type damage does not need to be repaired in the field.

McCAULEY PROPELLER SYSTEMS
OWNER/OPERATOR
INFORMATION MANUAL

CAUTION: The use of a rasp file is not recommended for field repairs. Rasp-type files will remove more metal than necessary, and may cause premature rejection of the blade at propeller overhaul.

NOTE: If the propeller blade has erosion damage and there are no signs of corrosion, no further action is required. However, it is recommended that erosion damage be protected from corrosion with a chemical conversion film coat (for example, Alodine) and then touch up the propeller paint in accordance with the Blade Painting procedures.

- (b) Give close attention to deice boots during visual inspection. Boot damage may have penetrated the boot heating element and damaged the blade. Remove the boot and inspect the propeller blade if this type of damage is suspected.

NOTE: Do not assume the deice boot (if installed) is not damaged if it is heating normally.

1 Small object damage is normally found on the leading edge and face side of the propeller blade. Damage will normally occur on reversing propellers on the camber side at the outboard stations.

- (c) It is very important that stress riser type damage be completely repaired. When filing the damaged area is complete, a fluorescent dye penetrant examination of the affected area should be performed, when possible, to verify that the stress riser has been completely removed.

NOTE: If it is not possible to inspect the repaired area using the fluorescent dye penetrant inspection method, the repaired region should be inspected with a minimum 10x power lens to ensure any sharp notches or cracks have been removed.

1 A stress riser can cause the failure of a propeller blade if not repaired properly.
2 A stress riser is an increase in stress intensity surrounding an area of reduced cross-sectional area. A sharp stress riser is an increased stress intensity attributed to a notch-like displacement of material resulting from a sharp object impact, leaving a very small radius at the bottom of the displaced material, refer to Figure 801.

NOTE: Sometimes a stress riser in the propeller may be referred to as a nick.

3 Stress riser damage found during a routine inspection must be field repaired if it is not beyond the field repair limits. If the damage appears to be beyond the field repair limits, the blade must be evaluated and/or replaced by an approved McCauley propeller service facility. Stress risers may be caused by sharp, hard objects striking the rotating blade, or can develop from corrosion such as exfoliation or intergranular type corrosion.

4 Blade erosion is the abrading of surface material attributed to impact with small particles such as sand, dirt, and water. Small object impact typically does not cause sharp bottom radiuses and therefore do not result in sharp stress risers or significant material displacement that elevate the stress intensity to a level which cause crack initiation. Erosion of the blade surface that does not result in stress risers, does not require field repair of the damaged surface. If significant material displacement has occurred, measure the area of the blade with the most erosion damage.

a Damage that is located on the leading or trailing edges must not exceed 0.094 inch (2.39 mm) in depth. Damage greater than 0.094 inch (2.39 mm) in depth is not field repairable.

b Damage that is located on a repairable area of the face or camber side of the blade must not exceed 0.061 inch (1.55 mm) in depth. Damage greater than 0.061 inch (1.55 mm) in depth is not field repairable.

C2010

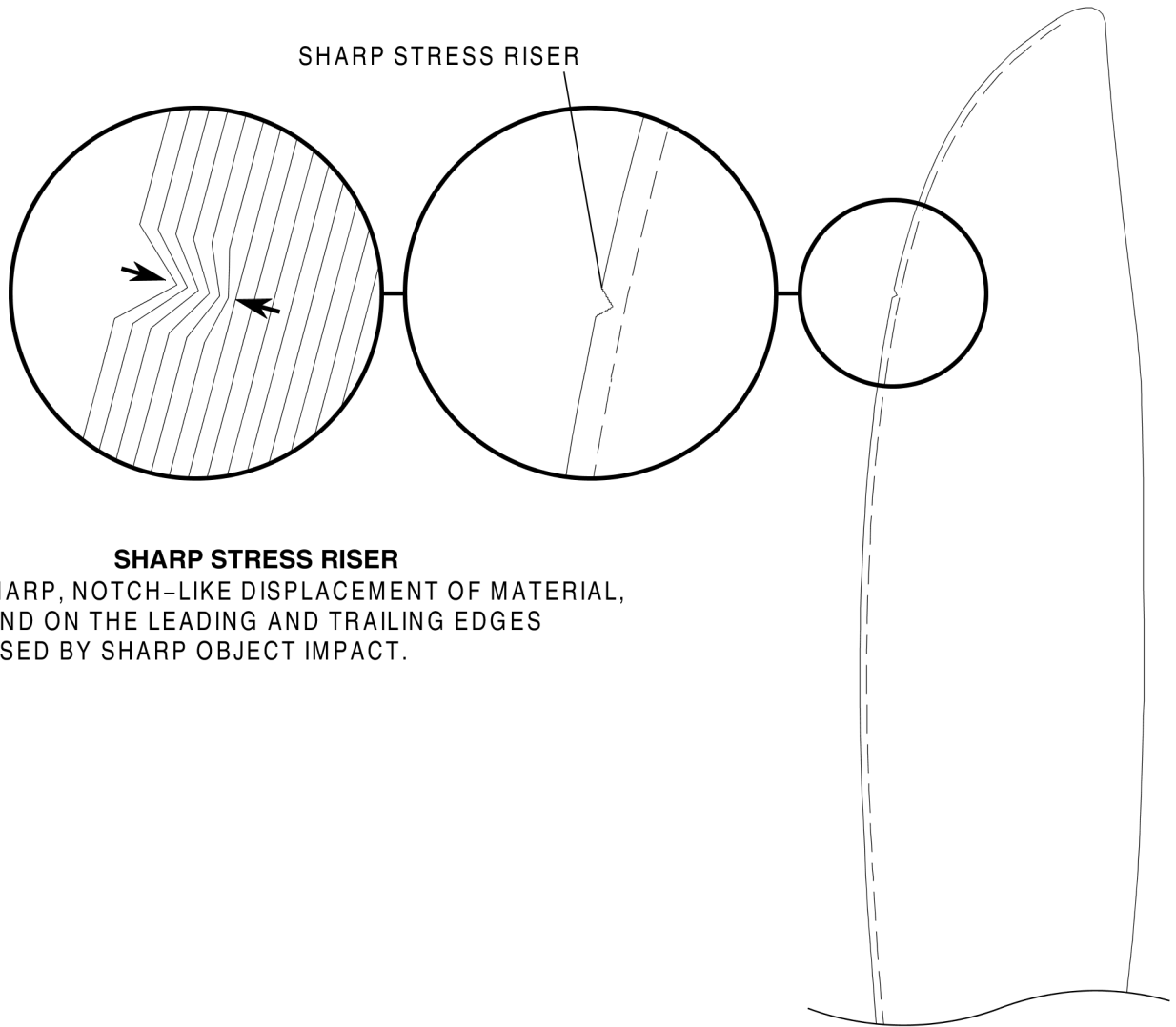

SHARP STRESS RISER

A SHARP, NOTCH-LIKE DISPLACEMENT OF MATERIAL,
FOUND ON THE LEADING AND TRAILING EDGES
CAUSED BY SHARP OBJECT IMPACT.

Sharp Stress Riser
Figure 801 (Sheet 1)

McCAULEY PROPELLER SYSTEMS
OWNER/OPERATOR
INFORMATION MANUAL

- 5 If corrosion is observed on the propeller:
- a For uniform etch type corrosion, remove the corrosion and clean the affected area of the propeller and chemical conversion film coat, and if applicable, touch up the paint in accordance with the Cleaning/Painting/Protective Treatments instructions.
 - b For pitting, intergranular or exfoliation type corrosion, remove the corrosion and examine the affected area for stress riser damage. If stress riser damage is found, repair the damage. Clean the affected area of the propeller and chemical conversion film coat, and if applicable, touch up the paint in accordance with the with the Cleaning/Painting/Protective Treatments instructions.

NOTE: After the corrosion is removed, measure the damaged area, damage that is located on the leading or trailing edges must not exceed 0.094 inch (2.39 mm) in depth and damage that is located on a repairable area of the face or camber side of the blade must not exceed 0.061 inch (1.55 mm) in depth.

- 6 If erosion is repaired, corrosion protect the propeller blade in the area of the repair. Chemical conversion film coat (for example, Alodine) the repaired area and then touch up the propeller paint in accordance with the with the Cleaning/Painting/Protective Treatments instructions.

(4) Repair Criteria

- (a) Repair stress riser damage. Stress riser damage is repaired by removing adjacent material from the damaged area so that there is no longer a notch of displaced material with a very small radius at the bottom of the damaged area. Material is removed with small smooth cut mill files, emery cloth, and/or sandpaper. When the stress riser removal is complete, perform a fluorescent dye penetrant inspection to verify that the stress riser has been completely removed. Refer to Non-Destructive Inspection Procedures for fluorescent dye penetrant inspection procedures.
- (b) Do not remove more material than what is required to remove the stress riser from the propeller blade. Unnecessary or excessive propeller blade material removal will cause premature replacement of the propeller blade at propeller overhaul.
- (c) Leading and Trailing Edge Repair Procedure
 - 1 Determine the depth of the damaged area.
 - a The depth of damage must be measured using a depth gage.
 - b Damage that is located on the leading or trailing edges must not exceed 0.094 inch (2.4 mm) in depth.
 - c Damage depth greater than this limit is not field repairable.

NOTE: An FAA approved Part 145 Propeller Repair Station or international equivalent may be able to do a repair. Contact McCauley Product Support for disposition of any damage that is deeper than the specified limits.

- 2 Remove metal at the damaged area starting back from and working toward the edge in such a way that the contour remains substantially the same. File strokes must run from blade shank to blade tip. Avoid abrupt changes in contour and blunt edges.
- 3 The length of the blended area shall be equal to 10 times the depth of the damage. Refer to Figure 802.
- 4 The finished repair should be the depth of the original damage plus 0.031 inch (0.8 mm)
- 5 Initial removal of material should be done using a small smooth cut mill file.
- 6 All traces of file marks in the repaired area should be removed with number 240 emery cloth or equivalent grit sandpaper.

McCAULEY PROPELLER SYSTEMS
OWNER/OPERATOR
INFORMATION MANUAL

- 7 Smooth the repaired area followed by polishing with number 320 emery cloth and 600 grit emery cloth or equivalent grit sandpaper.

NOTE: Do not use sandpaper or emery cloth that contains iron oxide material on aluminum propellers.

- 8 Determine the depth of the repaired damaged area.
- a The maximum depth of the damage repair area must be measured using a depth gage.
 - b The repair that is located on the leading or trailing edges must not exceed 0.125 inch (3.2 mm) in depth.
 - c Propeller damage depth greater than this limit is not field repairable.

NOTE: An FAA approved Part 145 Propeller Repair Station or international equivalent may be able to do a repair. Contact McCauley Product Support for disposition of any damage that is deeper than the specified limits.

(d) Face And Camber Repair Procedure

- 1 Determine the depth of the damaged area.
- a The depth of damage must be measured using a depth gage.
 - b Damage that is located on the face or camber sides of the propeller must not exceed 0.061 inch (1.55 mm) in depth.
 - c Damage depth greater than this limit is not field repairable.

NOTE: An FAA approved Part 145 Propeller Repair Station or international equivalent may be able to do a repair. Contact McCauley Product Support for disposition of any damage that is deeper than the specified limits.

CAUTION: Use extreme care to control the hand held grinder.

- 2 Remove metal at the damaged area by hand using a coarse grain emery cloth or by a hand held rotary grinder with 120 or finer grit bob. Do not use a hand file in this area.

NOTE: Do not use sandpaper or emery cloth that contains iron oxide material on aluminum propellers.

- 3 Grind blade with light pressure in a circular motion until damage is totally removed. The diameter of the repair shall be equal to 20 times the depth of damage. Refer to Figure 802.

- 4 The finished repair should be the depth of the original damage plus 0.002 inch (0.05 mm)

- 5 Smooth the repaired area with number 240 and 320 emery cloth or equivalent grit sandpaper.

- 6 Polish the repaired area with number 600 grit emery cloth or equivalent grit sandpaper.

NOTE: Do not use sandpaper or emery cloth that contains iron oxide material on aluminum propellers.

- 7 Determine the depth of the repaired damaged area.
- a The maximum depth of the damage repair area must be measured using a depth gage.
 - b The repair that is located on the face or camber sides of the propeller must not exceed 0.063 inch (1.6 mm) in depth.

McCAULEY PROPELLER SYSTEMS
OWNER/OPERATOR
INFORMATION MANUAL

- c Propeller damage depth greater than this limit is not field repairable.

NOTE: An FAA approved Part 145 Propeller Repair Station or international equivalent may be able to do a repair. Contact McCauley Product Support for disposition of any damage that is deeper than the specified limits.

- (e) Inspect Repaired Area
- 1 Do a fluorescent dye penetrant inspection to verify that the stress riser has been completely removed. Refer to Non-Destructive Inspection Procedures for fluorescent dye penetrant inspection procedures.
- (f) Blade Painting After Repair
- 1 Prepare the repaired area for touch up paint by wiping with a Methyl n-Propyl Ketone (MPK) dampened cloth.
 - 2 Corrosion protect the propeller blade in the area of the repair. Refer to Cleaning/Painting/Protective Treatments for instructions for the application of a chemical conversion film coating (for example, Alodine) on the repaired area of the propeller.
 - 3 Touch up the propeller paint in accordance with the procedures in Cleaning/Painting/Protective Treatments to blend the paint with the original finish.
 - 4 Recheck the dynamic balance of the propeller if the propeller is installed on a turbine engine.

B. Blade Painting

(1) General

- (a) Propeller blades are painted with polyurethane enamel paint. This paint provides optimum durability and abrasion resistance. If paint becomes eroded and is not repainted, damage to aluminum blade surface will be accelerated. This is particularly true at blade tips where operation in rain or reversing on sandy and/or wet runways can cause accelerated wear. It is, therefore, important to touch-up the paint on the propeller blades frequently as part of a regular maintenance schedule.

(2) Painting Materials and Procedures

WARNING: Some of the chemicals used in painting the propeller can be harmful to the skin and eyes. The manufacturer's safety precautions must be obeyed when handling paint and paint preparation materials.

NOTE: Follow the painting procedures specified by the paint manufacturer when painting the propeller.

- (a) It is recommended that final dry film paint thickness be 6 to 9 mils for best abrasion resistance.
- (b) For more information concerning the propeller paint, refer to the procedures in Cleaning/Painting/Protective Treatments.

NOTE: Repainting the entire propeller blade or the propeller assembly should only be accomplished at a McCauley authorized propeller service facility. Without the proper training and equipment, the static balance of the propeller can be affected by the application of paint.

2. Spinner Repair

- A. No repair is permitted on any McCauley spinner, spinner front support, or spinner bulkhead. Follow these guidelines to determine if a part is airworthy:
- (1) If the part has scratches and minor dents, the part can continue to be used.
 - (2) If the part is cracked, the part must be replaced.

McCAULEY PROPELLER SYSTEMS
OWNER/OPERATOR
 INFORMATION MANUAL

C53

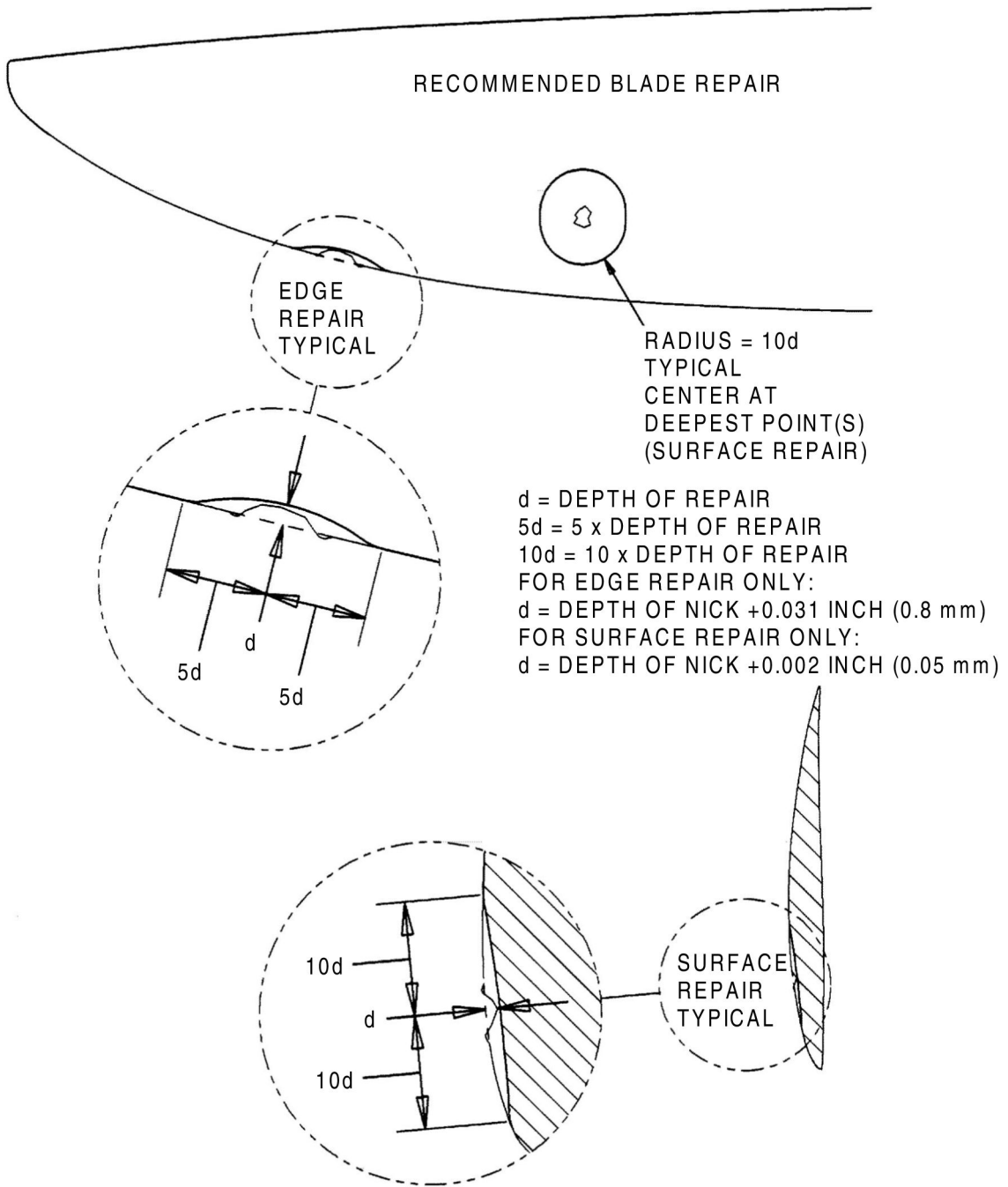

Field Blade Rework Criteria
 Figure 802 (Sheet 1)

McCAULEY PROPELLER SYSTEMS
OWNER/OPERATOR
INFORMATION MANUAL

C54

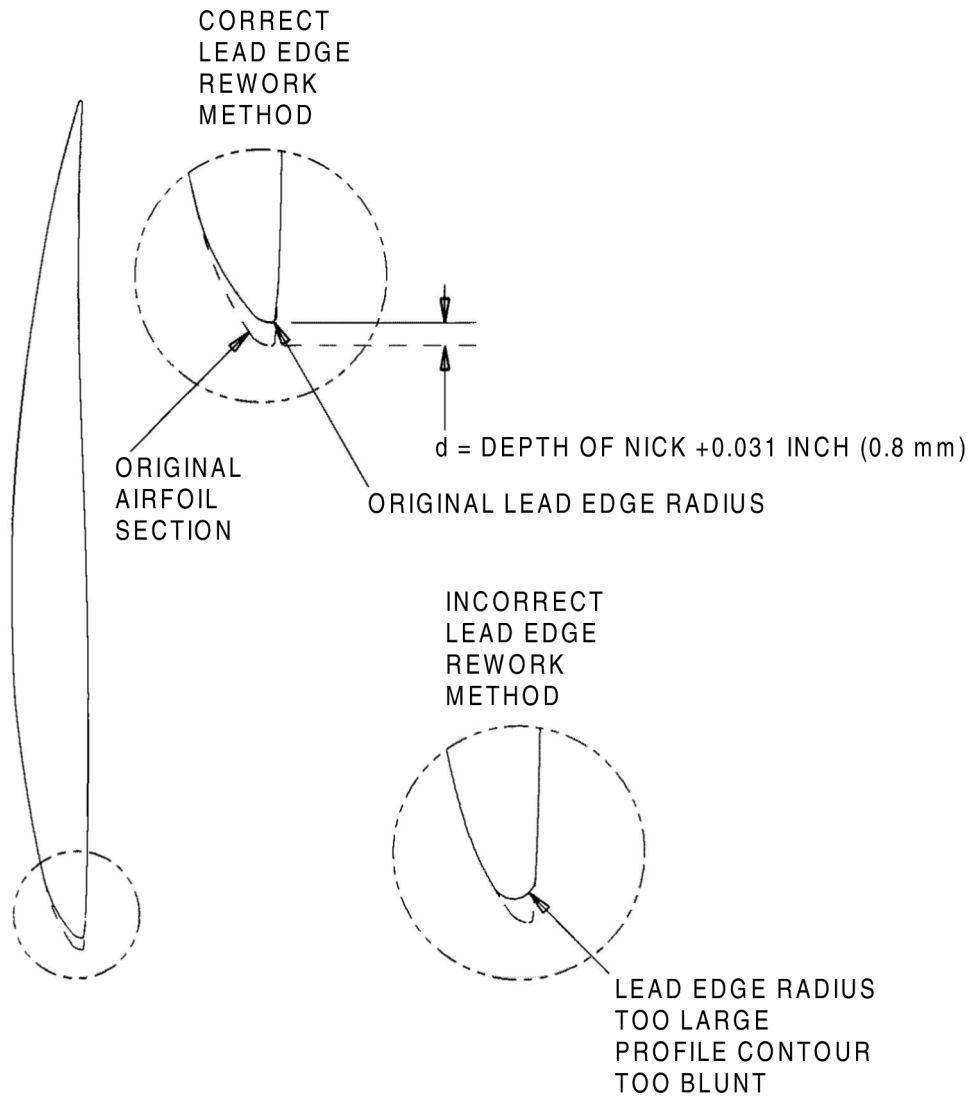

GENERAL RULES:
DO NOT REDUCE THE MAXIMUM THICKNESS OF SECTION.
KEEP THE ORIGINAL LEAD EDGE RADIUS.
BLEND TO THE PROFILE OF THE AIRFOIL SECTION.

Field Blade Rework Criteria
Figure 802 (Sheet 2)

McCAULEY PROPELLER SYSTEMS
OWNER/OPERATOR
 INFORMATION MANUAL

PROPELLER INSTALLATION PARTS LIST

1. General

- A. Use the Installation Parts List to identify and order correct replacement parts for propeller field maintenance.
- B. These parts may be purchased through your local authorized McCauley propeller service facility.

Table 1001. Installation Parts for Constant Speed Piston Engine Propellers

	C200 Series	C300 Series	C400 Series	C500 Series
Mount Nut	A-1639-2	A-1639-2	A-1639-2	A-1639-2
Mount Nut				A-1639-32
Spacer				A-4494
Mount O-ring	A-1633-3	A-1633-3	A-1633-3	A-1633-3
Mount O-ring Lycoming	A-1633-11		A-1633-11	A-1633-11
Mount O-ring				A-1633-49
Spinner Screw, bright nickel plated	A-1635-133		A-1635-133	A-1635-133
Spinner Screw, cadmium plated	A-1635-39		A-1635-39	A-1635-39
Spinner Washer, fiber	A-1638-5		A-1638-5	A-1638-5
Spinner Shim	B-3410-16		B-3410-16	B-3410-16
Spinner Shim	B-3410-32		B-3410-32	B-3410-32

NOTE 1: Mount nut A-1639-2 is 1/2-inch, A-1639-32 is 9/16-inch.

NOTE 2: Not all parts listed for a propeller series are required for every model propeller.

Table 1002. Installation Parts for Turbine Engine Propellers

	C600 Series	C650 Series	C700 Series	C750 Series	C1000 Series	C1100 Series
Mount Nut	A-1639-32	A-1639-32	A-1639-32	A-1639-32	A-1639-46	A-1639-32
Mount Nut					A-1639-32	
Spacer	A-4945	B-5096	B-5096	B-5096	B-5096	B-5096
Mount O-ring	A-1633-63	A-1633-72	A-1633-72	A-1633-72	A-1633-72	A-1633-72
Mount O-ring					A-1633-98	
Spinner Screw, bright nickel plated	A-1635-133	A-1635-133	A-1635-133	A-1635-133		A-1635-133
Spinner Screw, cadmium plated	A-1635-39	A-1635-39	A-1635-39	A-1635-39		
Spinner Screw, cadmium plated dyed black					A-1635-172	

McCAULEY PROPELLER SYSTEMS
OWNER/OPERATOR
 INFORMATION MANUAL

Table 1002. Installation Parts for Turbine Engine Propellers (continued)

	C600 Series	C650 Series	C700 Series	C750 Series	C1000 Series	C1100 Series
Spinner Washer, fiber	A-1638-5	A-1638-5	A-1638-5	A-1638-5	A-1638-44	A-1638-5
Spinner Shim	B-4940-1	B-4940-1	B-4940-1	B-4940-1	B-4940-1	B-4940-1
Spinner Shim	B-4940-2	B-4940-2	B-4940-2	B-4940-2	B-4940-2	B-4940-2

NOTE 1: C1100 Series does not include C1101 through C1104.

Table 1003. Installation Parts for Fixed Pitch Propellers

Basic Propeller Model Number	Spacer P/N	Dowel P/N	Fixed Pitch Bolt Kit						
			Bolt Kit P/N	Bolt Dia.	Dri-illed Head	No. Bolts	Bolt P/N	Washer P/N	Nut P/N
1A100/ACM	B-3400	A-297 3-6	B-4622-1 0	3/8	Yes	6	A-2513-11	A-1638-13	NA
1P235/AFA	NA	NA	B-4622-2 5	1/2	Yes	6	A-2513-13	A-1638-2	NA
C172/AGM	B-3515	A-297 3-6	B-4622-1 5	3/8	Yes	6	A-2513-25	A-1638-13	NA
C190/ALM	C-3635	Note 2	B-4622-8	3/8	Yes	6	A-2513-30	A-1638-13	A-1639-6
1A200/AOM	NA	A-4001	B-4622-4	1/2	No	6	A-2513-17	A-1638-2	A1639-2
1A175/ATM	B-3898	A-297 3-6	B-4622-2 0	7/16	Yes	6	A-2513-38	A-1638-11	NA
1A105/BCM	B-3927	A-297 3-6	B-4622-1 6	3/8	No	6	A-2513-20	A-1638-14	NA
1B235/BFA	B-3637	A-297 3-6	B-4622-2 7	1/2	Yes	6	A-2513-33	A-1638-10	NA
1A170/BMS	B-6627	A-297 3-6	B-4622-4 1	1/2	Yes	6	A-2513-99	A-1638-2	NA
1A135/BRM	B-3718	A-297 3-7	B-4622-1	1/2	Yes	6	A-2513-18	A-1638-10	A-1639-2
		A-4001							
1C172/BTM	B-4381	A-297 3-6	B-4622-3 7	7/16	Yes	6	A-2513-79	NA	NA
1A90/CF	NA	NA	B-4622-9	3/8	Yes	6	A-2513-8	A-1638-13	NA
1A90/CF Note 3	NA	NA	B-4622-4 2	3/8	Yes	6	A-2513-9	A-1638-13	A-1639-6
1A170/CFA	B-3637	A-297 3-6	B-4622-2 3	1/2	Yes	6	A-2513-33	A-1638-2	NA
1A90/CH	NA	Note 2	B-4622-4 2	3/8	No	6	A-2513-9	A-1638-13	A-1639-6
1C90/CLM	B-3515	A-297 3-6	B-4622-3 3	3/8	Yes	6	A-2513-41	A-1638-13	NA

McCAULEY PROPELLER SYSTEMS
OWNER/OPERATOR
 INFORMATION MANUAL

Table 1003. Installation Parts for Fixed Pitch Propellers (continued)

Basic Propeller Model Number	Spacer P/N	Dowel P/N	Fixed Pitch Bolt Kit						
			Bolt Kit P/N	Bolt Dia.	Drilled Head	No. Bolts	Bolt P/N	Washer P/N	Nut P/N
1B90/CM	NA	NA	B-4622-9	3/8	Yes	6	A-2513-8	A-1638-13	NA
1B90/CM Note 3	NA	Note 2	B-4622-4 2	3/8	Yes	6	A-2513-9	A-1638-13	A-1639-6
1A135/CRM	B-3718	A-297 3-7	B-4622-1	1/2	Yes	6	A-2513-18	A-1638-10	A-1639-2
		A-4001							
1C160/CTM	B-3898	A-297 3-6	B-4622-2 0	7/16	Yes	6	A-2513-38	A-1638-11	NA
1A101/DCM	NA	NA	B-4622-9	3/8	Yes	6	A-2513-8	A-1638-13	NA
1A170/DF	NA	NA	B-4622-3 0	3/8	Yes	8	A-2513-10	A-1638-13	NA
1A200/DFA	B-3434	A-297 3-6	B-4622-2 8	1/2	Yes	6	A-2513-18	A-1638-10	NA
1B235/DFC	NA	A-4001	B-4622-5	1/2	No	6	A-2513-16	A-1638-2	A-1639-2
1C90/DLM	B-4160	A-297 3-6	B-4622-1 3	3/8	Yes	6	A-2513-43	A-1638-13	NA
1A170/DM	NA	NA	B-4622-3 0 (Short Bolt Kit)	3/8	Yes	8	A-2513-10	A-1638-13	NA
1A170/DM	NA	NA	B-4622-3 6 (Long Bolt Kit)	3/8	Yes	8	A-2513-23	A-1638-14	NA
1A175/DM	NA	NA	B-4622-3 0 (Short Bolt Kit)	3/8	Yes	8	A-2513-10	A-1638-13	NA
1A175/DM	NA	NA	B-4622-3 6 (Long Bolt Kit)	3/8	Yes	8	A-2513-23	A-1638-14	NA
1A135/DRM	C-7639	A-297 3-7	B-4622-1	1/2	Yes	6	A-2513-18	A-1638-10	A-1639-2
		A-4001							
1C160/DTM	B-4516	A-297 3-6	B-4622-2 0	7/16	Yes	6	A-2513-38	A-1638-11	NA
	C-4592								
1B90/ECM	B-3927	A-297 3-6	B-4622-1 6	3/8	Yes	6	A-2513-20	A-1638-14	NA
1A170/EFA	B-4020	A-297 3-6	B-4622-2 4	1/2	Yes	6	A-2513-39	A-1638-2	NA
1B235/EFC	C-7744	A-297 3-7	B-4622-4 5	1/2	Yes	6	A-2513- 103	A-1638-2	A-1639-2
		A-4001							

McCAULEY PROPELLER SYSTEMS
OWNER/OPERATOR
 INFORMATION MANUAL

Table 1003. Installation Parts for Fixed Pitch Propellers (continued)

Basic Propeller Model Number	Spacer P/N	Dowel P/N	Fixed Pitch Bolt Kit						
			Bolt Kit P/N	Bolt Dia.	Drilled Head	No. Bolts	Bolt P/N	Washer P/N	Nut P/N
1C160/EGM	NA	NA	B-4622-14	3/8	Yes	6	A-2513-19	A-1638-13	NA
1C172/EM	NA	A-4001	B-4622-3	1/2	No	6	A-2513-14	A-1638-10	A-1639-2
1A175/ETM	B-4516	A-297 3-6	B-4622-20	7/16	Yes	6	A-2513-38	A-1638-11	NA
	C-4592								
1A200/FA	NA	NA	B-4622-26	1/2	Yes	6	A-2513-15	A-1638-2	NA
1A175/FC	NA	A-4001	B-4622-4	1/2	No	6	A-2513-17	A-1638-2	A-1639-2
1C200/FC	NA	A-4001	B-4622-4	1/2	No	6	A-2513-17	A-1638-2	A-1639-2
1B90/FCM	B-4301	A-297 3-6	B-4622-17	3/8	Yes	6	A-2513-53	A-1638-14	NA
1A170/FFA	B-4273	A-297 3-6	B-4622-38	1/2	Yes	6	A-2513-71	NA	NA
1C160/FGM	B-4561	A-297 3-6	B-4622-19	3/8	Yes	6	A-2513-41	A-1638-14	NA
1A200/FM	NA	NA	B-4622-31	7/16	Yes	8	A-2513-12	A-1638-11	NA
1A101/GCM	B-4304	A-297 3-6	B-4622-11	3/8	Yes	6	A-2513-51	A-1638-13	NA
1A170/GM	NA	NA	B-4622-14	3/8	Yes	6	A-2513-19	A-1638-13	NA
1A175/GM	NA	NA	B-4622-14	3/8	Yes	6	A-2513-19	A-1638-13	NA
1A175/GMA	B-3515	A-297 3-6	B-4622-15	3/8	Yes	6	A-2513-25	A-1638-13	NA
1A101/HCM	B-4351	A-297 3-6	B-4622-12	3/8	Yes	6	A-2513-77	A-1638-14	NA
1A200/HFA	B-4585	A-297 3-6	B-4622-29	1/2	Yes	6	A-2513-70	A-1638-10	NA
1B200/HM	C-1225	NA	B-4622-31	7/16	Yes	8	A-2513-12	A-1638-11	NA
1A135/JCM	B-3927	A-297 3-6	B-4622-18	3/8	Yes	6	A-2513-43	A-1638-14	NA
1A170E/JFA	C-5464	A-297 3-6	B-4622-40	1/2	Yes	6	A-2513-92	A-1638-2	NA
	C-7726								
1A170E/JHA	C-5464	A-297 3-6	B-4622-40	1/2	Yes	6	A-2513-92	A-1638-2	NA
	C-7726								

McCAULEY PROPELLER SYSTEMS
OWNER/OPERATOR
 INFORMATION MANUAL

Table 1003. Installation Parts for Fixed Pitch Propellers (continued)

Basic Propeller Model Number	Spacer P/N	Dowel P/N	Fixed Pitch Bolt Kit						
			Bolt Kit P/N	Bolt Dia.	Drilled Head	No. Bolts	Bolt P/N	Washer P/N	Nut P/N
1A135/KCM	B-4446	A-297 3-6	B-4622-1 9	3/8	Yes	6	A-2513-41	A-1638-14	NA
1A170/KFA	B-4273	A-297 3-6	B-4622-3 8	1/2	Yes	6	A-2513-71	NA	NA
1A170/L			B-4622-3 0	3/8	Yes	8	A-2513-10	A-1638-13	NA
1B90/LCM	B-3400	A-297 3-6	B-4622-1 0	3/8	Yes	6	A-2513-11	A-1638-13	NA
1C90/LF	C-1210	Note 2	B-4622-7	3/8	Yes	6	A-2513-7	A-1638-13	A-1639-6
1C235/LFA	C-7726	A-297 3-6	B-4622-4 0	1/2	Yes	6	A-2513-92	A-1638-2	NA
	C-5464								
1A170/LL	NA	NA	B-4622-3 0	3/8	Yes	8	A-2513-10	A-1638-13	NA
1C90/LM	C-1210	Note 2	B-4622-7	3/8	Yes	6	A-2513-7	A-1638-13	A-1639-6
1A100/MCM	NA	NA	B-4622-9	3/8	Yes	6	A-2513-8	A-1638-13	NA
1C172/MDM	NA	NA	B-4622-3 0	3/8	Yes	8	A-2513-10	A-1638-13	NA
1C172/MFA	NA	NA	B-4622-2 5	1/2	Yes	6	A-2513-13	A-1638-2	NA
1B175/MFC	NA	A-4001	B-4622-5	1/2	No	6	A-2513-16	A-1638-2	A-1639-2
1C172/MGM	NA	NA	B-4622-1 4	3/8	Yes	6	A-2513-19	A-1638-13	NA
1C172/MTM	NA	A-297 3-6	B-4622-2 0	7/16	Yes	6	A-2513-38	A-1638-11	NA
1A102/OCM	C-4513	A-297 3-6	B-4622-1 2	3/8	Yes	6	A-2513-77	A-1638-14	NA
	C-4593								
1D200/OM	NA	A-4001	B-4622-5	1/2	No	6	A-2513-16	A-1638-2	A-1639-2
1A101/PCM	C-4513	A-297 3-6	B-4622-1 2	3/8	Yes	6	A-2513-77	A-1638-14	NA
	C-4593								
1P235/PFA	NA	A-297 3-6	B-4622-2 8	1/2	Yes	6	A-2513-18	A-1638-10	NA
1A135/RM	NA	A-4001	B-4622-2	1/2	No	6	A-2513-58	A-1638-2	A-1639-2
1C172/SBTM	B-4425	A-297 3-6	B-4622-3 7	7/16	Yes	6	A-2513-79		NA
1A105/SCM	NA	NA	B-4622-9	3/8	Yes	6	A-2513-8	A-1638-13	NA
1A170/SFA	NA	NA	B-4622-2 5	1/2	Yes	6	A-2513-13	A-1638-2	NA

McCAULEY PROPELLER SYSTEMS
OWNER/OPERATOR
 INFORMATION MANUAL

Table 1003. Installation Parts for Fixed Pitch Propellers (continued)

Basic Propeller Model Number	Spacer P/N	Dowel P/N	Fixed Pitch Bolt Kit						
			Bolt Kit P/N	Bolt Dia.	Dri-illed Head	No. Bolts	Bolt P/N	Washer P/N	Nut P/N
1A170/SFC	NA	A-4001	B-4622-5	1/2	No	6	A-2513-16	A-1638-2	A-1639-2
1A175/SFC	NA	A-4001	B-4622-5	1/2	No	6	A-2513-16	A-1638-2	A-1639-2
1A105/SLM	C-1210	Note 2	B-4622-7	3/8	Yes	6	A-2513-7	A-1638-13	A-1639-6
1A162/TCD	B-7925	A-7952	B-4622-4 9	3/8	No	6	A-2513- 105	A-1638-13 and A-1638-14	A-1639-6
1A103/TCM	NA	NA	B-46 22-43 (NOTE1)	3/8	Yes	6	A-2513-78	NA	NA
1C172/TM	B-3821	A-297 3-6	B-4622-2 2	7/16	No	6	A-2513-35	A-1638-11	NA
1A200/WFA	B-3637	A-297 3-6	B-4622-4 4	1/2	Yes	6	A-2513- 102	A-1638-10	NA

NOTE 1: Bolt Kit B-4622-43 contains 6 ea. A-2513-78 bolts, 6 ea. B-73036 mylor gaskets, 1 ea. B-7287 Reinforcement Plate, and 1 ea. drawing B-7387..

NOTE 2: A-1170 bushings are included with the bolt kit.

NOTE 3: For propellers mounted on engines with a tapered/splined crankshaft.

McCAULEY PROPELLER SYSTEMS
OWNER/OPERATOR
INFORMATION MANUAL

DEICE SYSTEM DESCRIPTION AND OPERATION

1. Introduction

- A. This section provides installation, service, overhaul, and parts information for electrothermal propeller deice systems and equipment manufactured by McCauley Propeller Systems. All information is current at the time of publication but is subject to change. Future information will be provided in the form of McCauley service letters or bulletins or by revisions to this manual.

NOTE: All data in this manual is applicable only to parts manufactured by McCauley. Some aircraft manufacturers use some but not all components of the deice systems designed by McCauley. Information concerning maintenance of components not supplied by McCauley and concerning operation of systems containing additional or substituted components should be obtained from the TC or STC holder. Section 61-10-40, Deice System Parts Lists, Electrothermal Deice Components Installation Lists provides information where component part numbers manufactured by McCauley can be found.

2. Applicable Regulations

- A. All maintenance and inspection procedures should be performed by qualified personnel. All work on deice systems must comply with FAA Advisory Circular 43, Title 14 of the Code of Federal Regulations (CFR) Part 23, and superseding FAA releases. Where hardware or components have provisions for safety wiring, make sure that safety wire is installed in accordance with NASM33540, General Practices For Safety Wiring, Safety Cabling, Cotter Pinning.

3. Installation Description

- A. The propeller deice system consists of the following components (refer to Figure 1):
- Electrothermal deice boots bonded to each propeller blade.
 - Slip ring assembly mounted on propeller for distribution of power to each deice boot.
 - Brush block assembly, mounted on engine with mounting bracket, to transfer current to the rotating slip ring assembly.
 - Deice timer to cycle electric current to the deice boots in the proper sequence.
 - An ammeter to indicate correct system load (See NOTE).
 - An external shunt or ammeter with internal shunt (See NOTE).
 - A manually operated ON-OFF circuit breaker type switch or separate circuit breaker and switch (See NOTE).

NOTE: Typically supplied by the airplane manufacturer.

4. Principles Of Operation

- A. The propeller deice system is an electrothermal type system which applies heat to the surfaces of the propeller blade where ice would normally adhere. Deicing is accomplished by raising the deice boot surface temperature sufficiently to reduce the bond between ice and boot allowing centrifugal force and scavenging airflow to sling ice from the propeller. To conserve power and effectively remove ice, power is provided to the deice boots in timed intervals rather than continuously. The time interval between heating cycles is necessary to permit ice to form and build up slightly prior to removal. The frequency and duration of power applied to the deice boot is controlled by the deice timer. Specific requirements for deice timer time cycles depend upon the use of single or dual element deice boots, single or twin engine aircraft, specific CFR requirements, and airframe manufacturer's philosophy. To maintain rotational balance of the propeller, the entire deice boot (single element boot) on each blade of a propeller or corresponding sections of the deice boots (dual element boot) on each blade are heated.

5. Deice Systems

- A. McCauley electrothermal deice systems differ, basically, in three areas:
- (1) Number of Engines
 - Single or twin engine aircraft.

McCAULEY PROPELLER SYSTEMS
OWNER/OPERATOR
 INFORMATION MANUAL

C1850

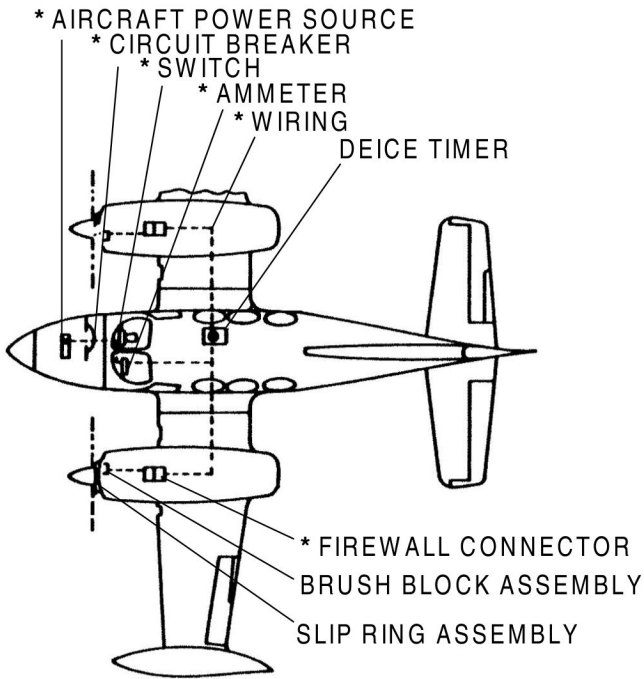

TYPICAL TWIN ENGINE SYSTEM

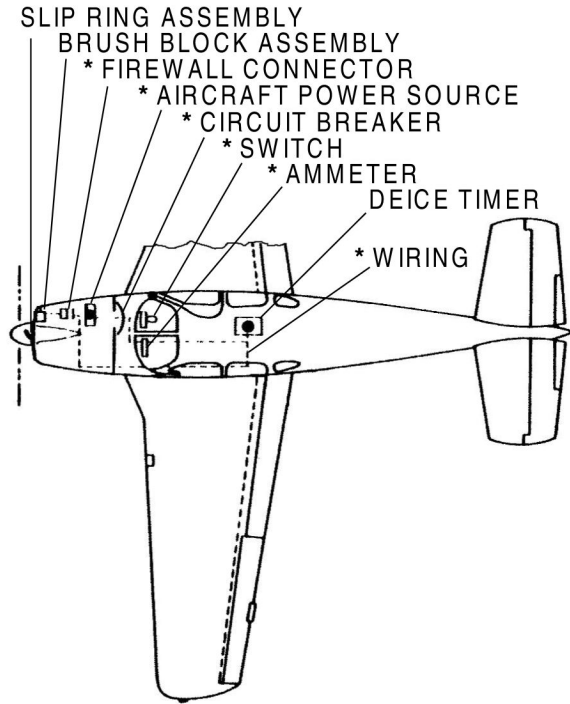

TYPICAL SINGLE ENGINE SYSTEM

* TYPICALLY SUPPLIED BY AIRCRAFT MANUFACTURER

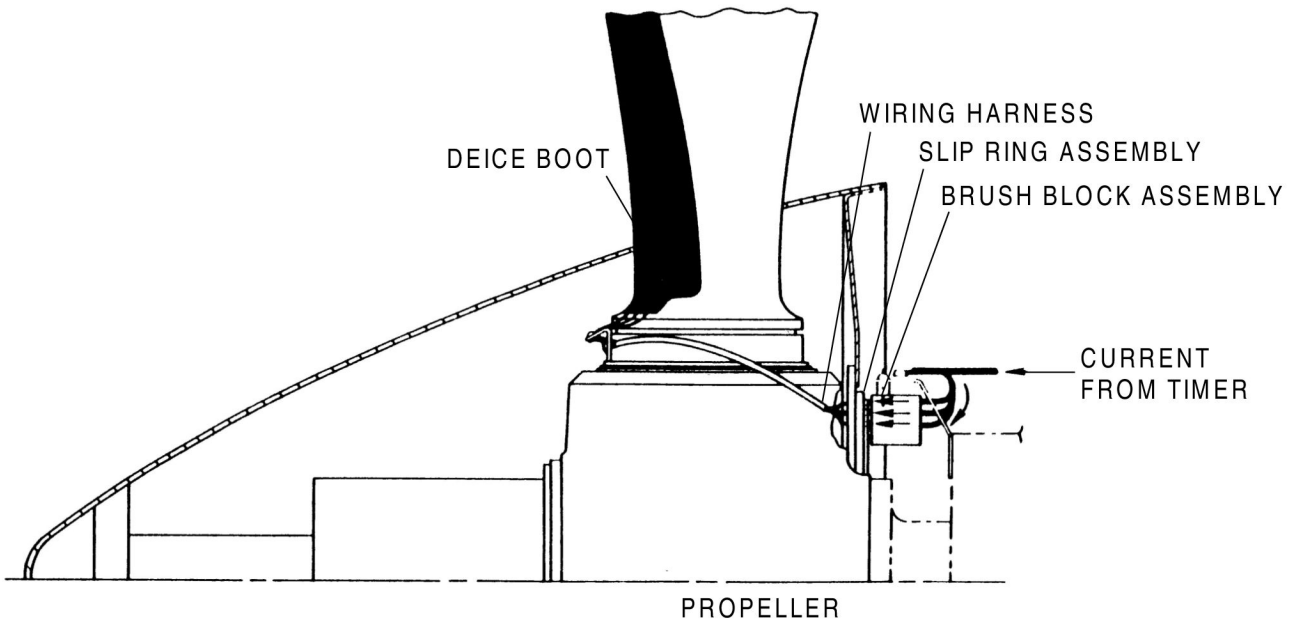

Typical Deice System
 Figure 1 (Sheet 1)

McCAULEY PROPELLER SYSTEMS
OWNER/OPERATOR
INFORMATION MANUAL

- (2) Deice Boot Heating Element (refer to Figure 2)
 - Single or dual element.
- (3) Slip Ring Installation (refer to Figure 3)
 - Part of starter ring gear (new, modified, ring gear incorporating slip ring assembly). (Utilized only on Lycoming engine applications.)
 - Slip ring assembly mounted and supplied as part of propeller assembly. (Pratt & Whitney engine installation.)
 - A pulley/slip ring assembly mounted between the propeller/engine flange and the back of the propeller hub. (Typically used where pulley is air conditioner and/or alternator drive.)
 - Separate slip ring assembly (attached to back of propeller hub or mounted between propeller/engine flange and propeller hub).

6. Types of Deice Systems

- A. The following methods of deice operations are used for effective removal of ice and to maintain rotational balance of the propeller.
- B. System with Single Element Deice Boots (Refer to Figure 4 for twin engine aircraft; refer to Figure 5 for single engine aircraft.)
 - (1) In the single element type system, each deice boot has only one electrothermal heating element.
 - (2) On twin engine applications the deice timer provides power to all deice boots of one propeller when the switch is turned on. The timer then switches power to the other propeller for the same length of time. This cycle repeats itself as long as the switch remains on.
 - (3) However, there are twin engine, four blade, slow turn engine applications equipped with McCauley propellers, and deice systems that differ from the above system. In these systems a separate deice timer is provided for each engine/propeller. When the switch is turned on, the timers switch power to only two blades of each four-bladed propeller (blades located in a 180 degree relationship). Then, the timers switch power to the adjacent two blades of each propeller for the same length of time, which repeats this cycle until the switch is turned off. This type of cycle is accomplished by utilizing a three-ring slip ring which has two boots of each propeller wired to the inboard ring and two boots wired to the outboard ring. Thus, when the timer switches power between the inboard and outboard ring, it is essentially distributing power to two adjacent blades at one time (this type of system is shown in Figure 8).
 - (4) On single engine aircraft the timer provides power to all deice boots of the propeller when the switch is energized. The timer then switches the power off for the same period of time. This cycle will repeat as long as the switch remains on.
- C. System with Dual Element Deice Boots (Refer to Figure 6 for twin engine aircraft; refer to Figure 7 for single engine aircraft.)
 - (1) On a dual element type system, each deice boot has two separate electrothermal heating elements, an inboard and an outboard section. When the switch is turned ON, the timer provides power through the brush block and slip ring assemblies to all outboard heating elements on one propeller. Then, the timer switches power to all inboard heating elements on the same propeller. This outboard-inboard sequence is important since the loosened ice tends to move outward.
 - (2) For single engine aircraft this cycle is repeated. For twin engine aircraft, power is switched to the other propeller where the same sequence is followed: first all outboard heating elements then switches to all inboard heating elements. As long as the switch remains on, the cycle will repeat itself.

7. Description of Deice System Components

- A. Deice Boots
 - (1) The deice boot has either one or two heating elements. These heating elements are protected by plies of rubber and fabric with a breeze surface made of a neoprene compound for erosion resistance. One side of the boot has a smooth matte finish while the other side has a fabric impressed finish to ensure a good bond between the boot and the propeller blade.
 - (2) Single element deice boots have two leads: one power input, one ground.

McCAULEY PROPELLER SYSTEMS
OWNER/OPERATOR
INFORMATION MANUAL

C1851

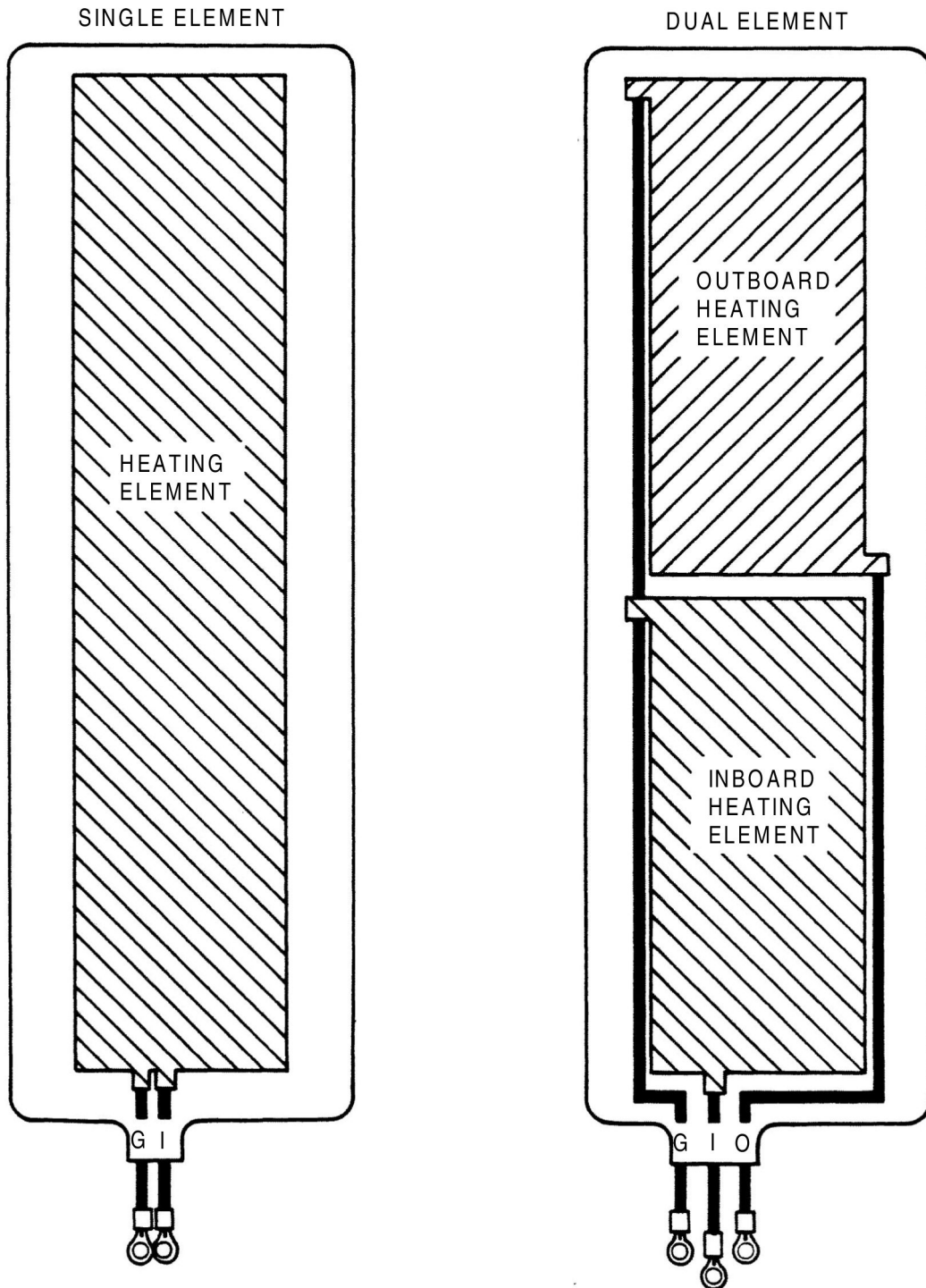

Types of Deice Boots
Figure 2 (Sheet 1)

McCAULEY PROPELLER SYSTEMS
OWNER/OPERATOR
INFORMATION MANUAL

C1852

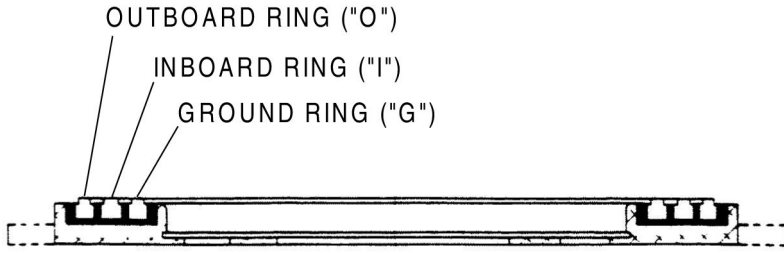

SLIP RING ASSEMBLY
(MOUNTED EITHER SEPARATELY OR
AN INTEGRAL PART OF PROPELLER)

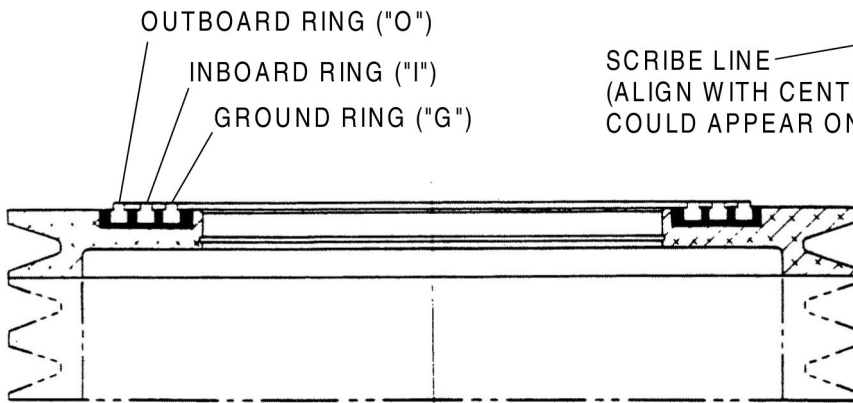
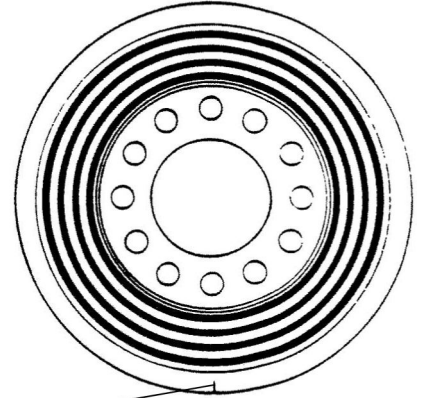

SCRIBE LINE
(ALIGN WITH CENTERLINE OF ANY BLADE)
COULD APPEAR ON EITHER SIDE OF ASSEMBLY

PULLEY/SLIP RING ASSEMBLY

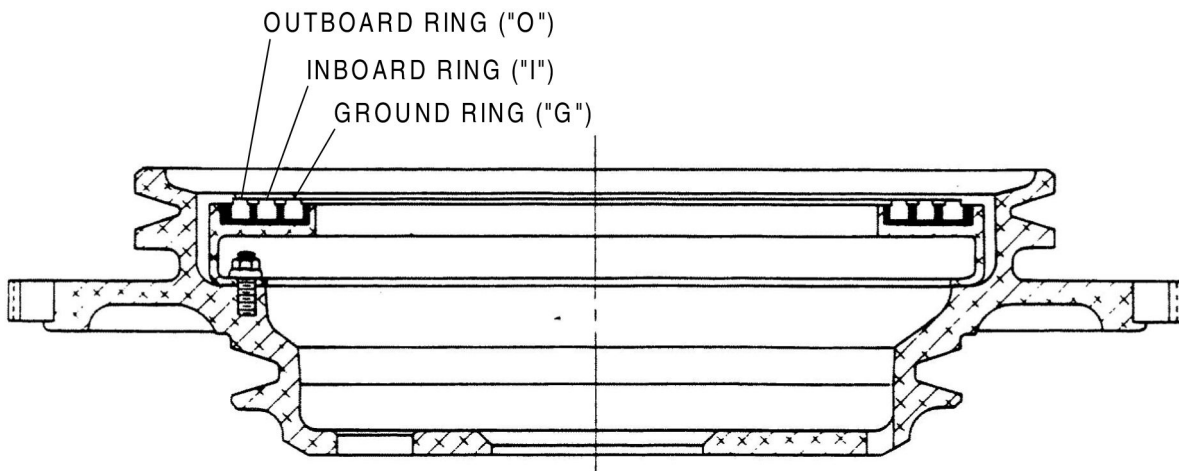

STARTER RING GEAR/SLIP RING ASSEMBLY

Types of Slip Ring Assemblies
Figure 3 (Sheet 1)

McCAULEY PROPELLER SYSTEMS
OWNER/OPERATOR
INFORMATION MANUAL

C1853

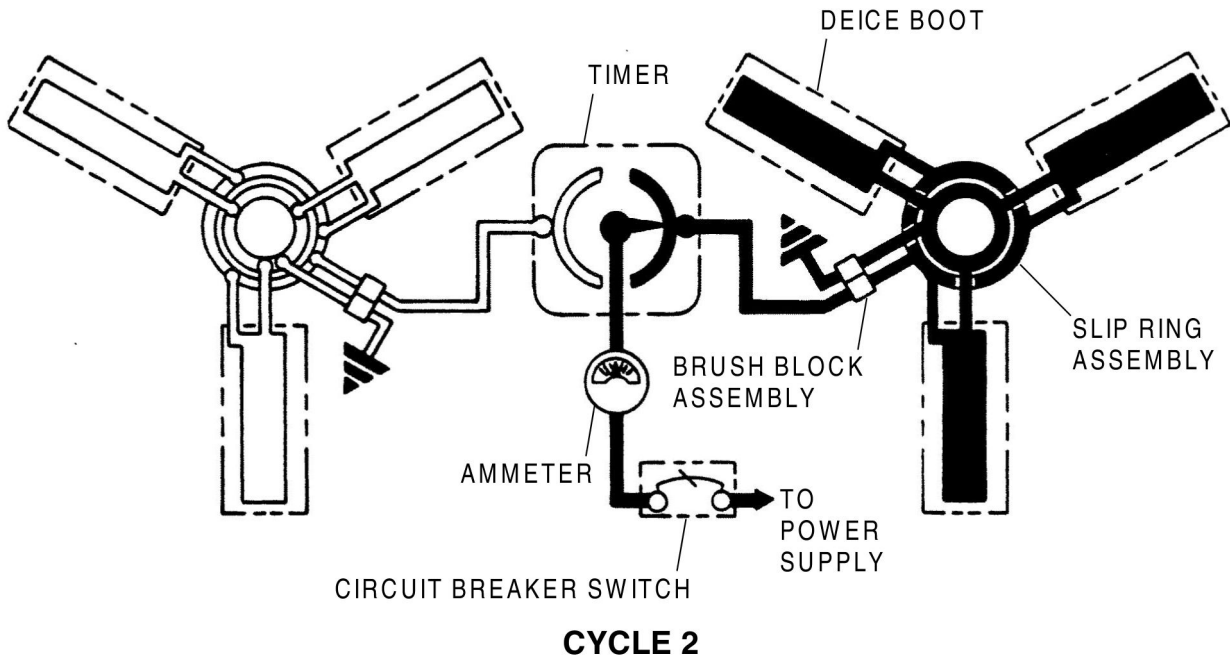
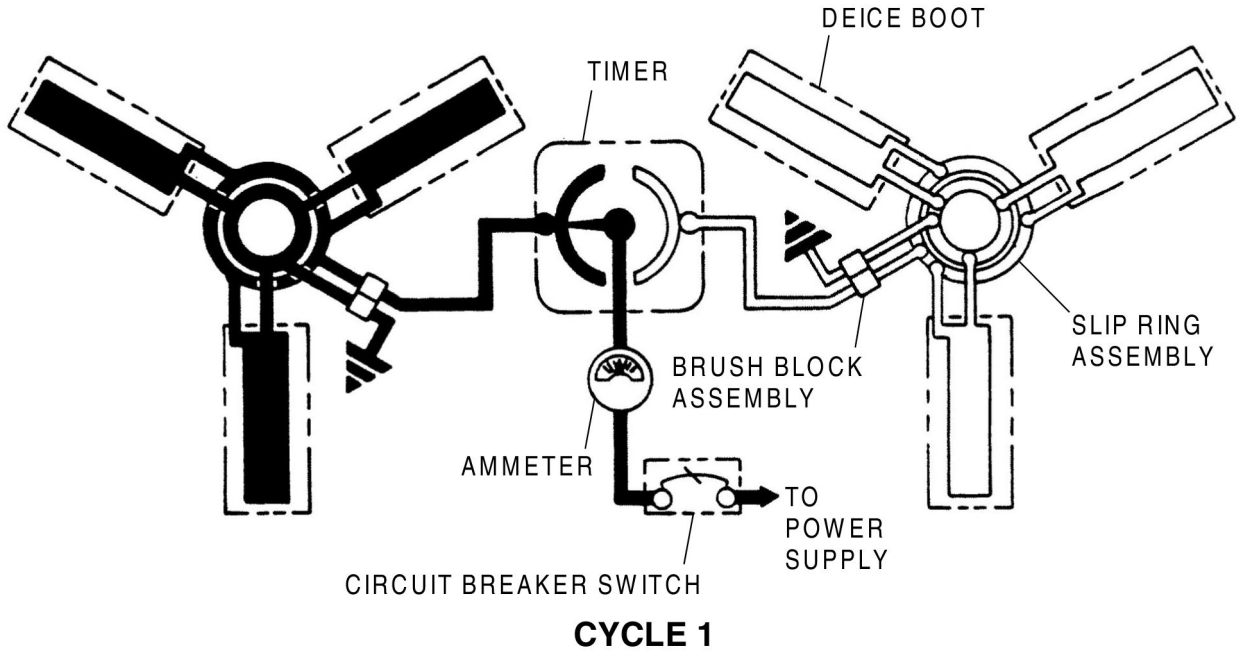

Single Element, Twin Engine Cycle Sequence
Figure 4 (Sheet 1)

McCAULEY PROPELLER SYSTEMS
OWNER/OPERATOR
INFORMATION MANUAL

C1854

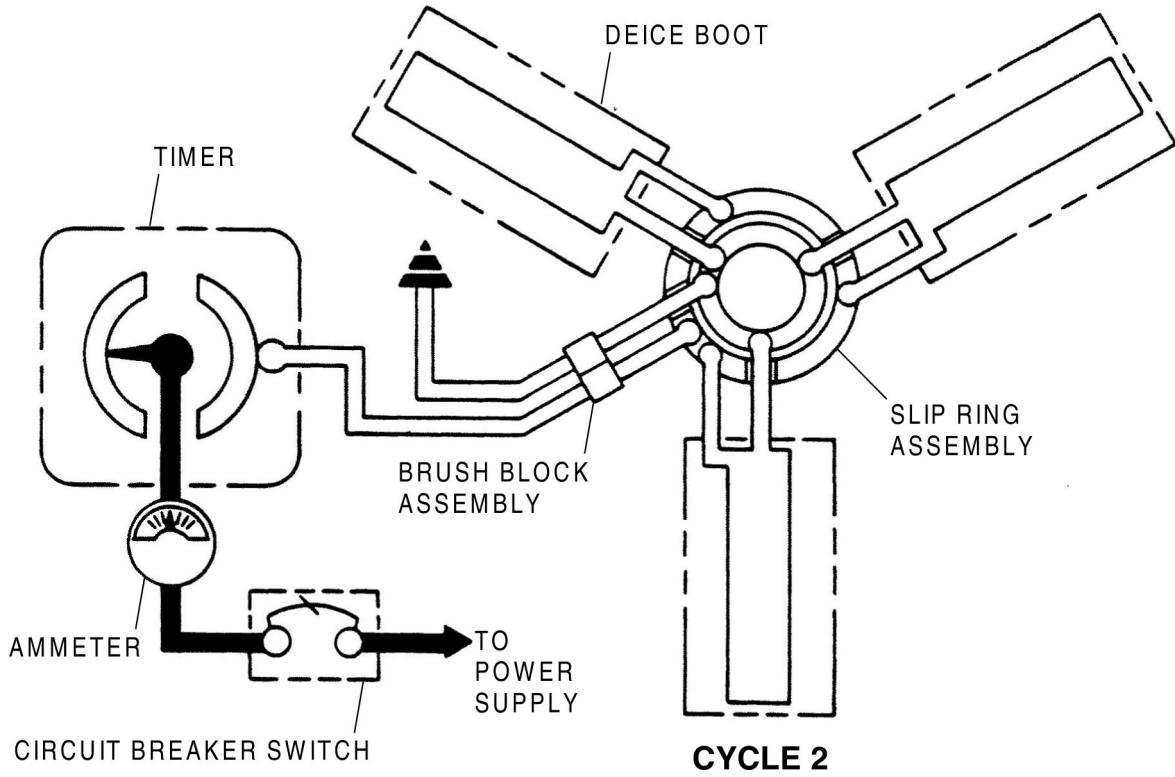
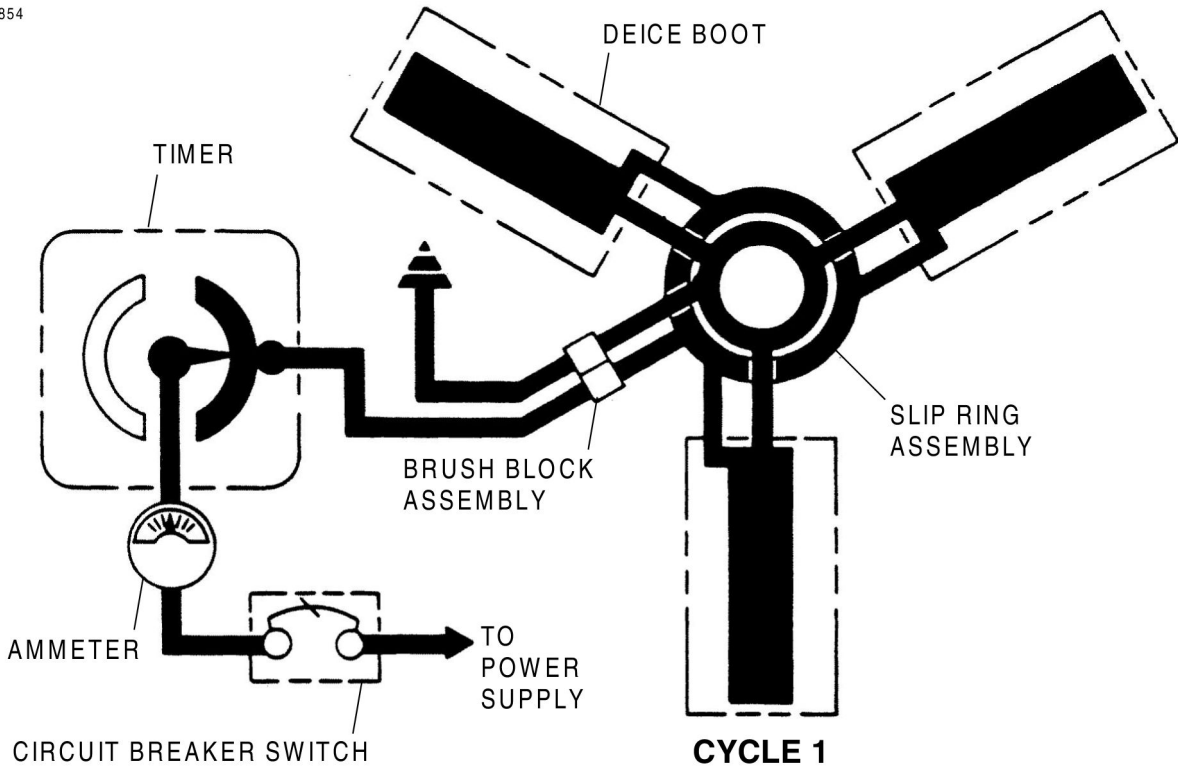

Single Element, Single Engine Cycle Sequence
Figure 5 (Sheet 1)

McCAULEY PROPELLER SYSTEMS
OWNER/OPERATOR
INFORMATION MANUAL

C1855

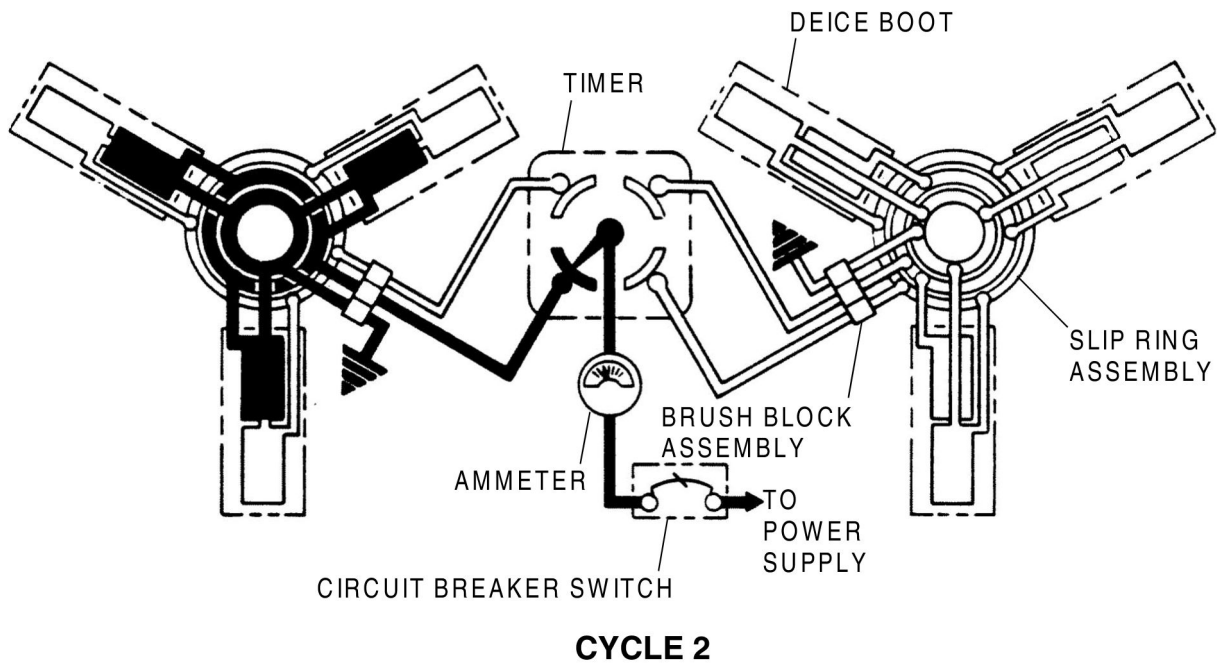
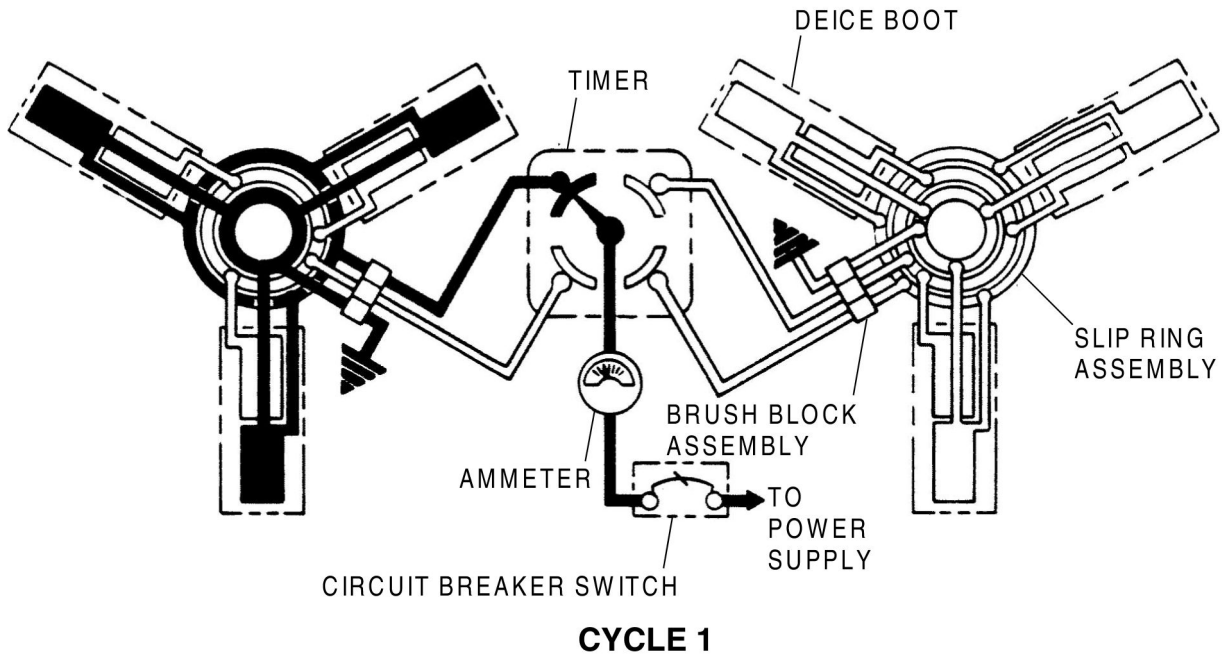

Dual Element, Twin Engine Cycle Sequence
Figure 6 (Sheet 1)

McCAULEY PROPELLER SYSTEMS
OWNER/OPERATOR
INFORMATION MANUAL

C1856

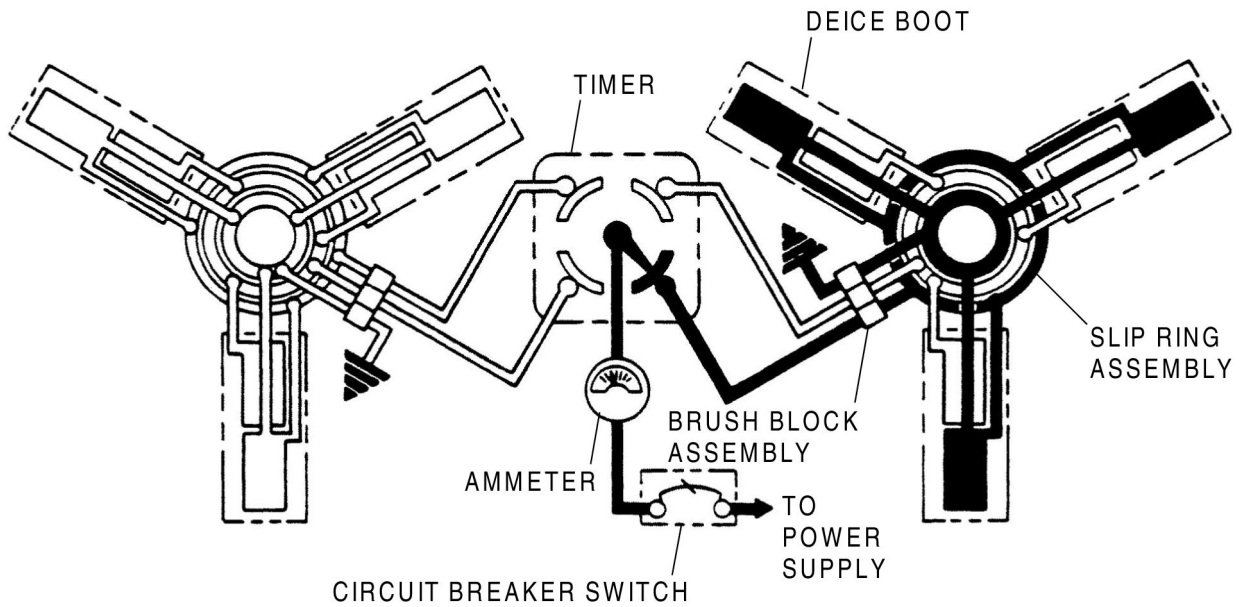

CYCLE 3

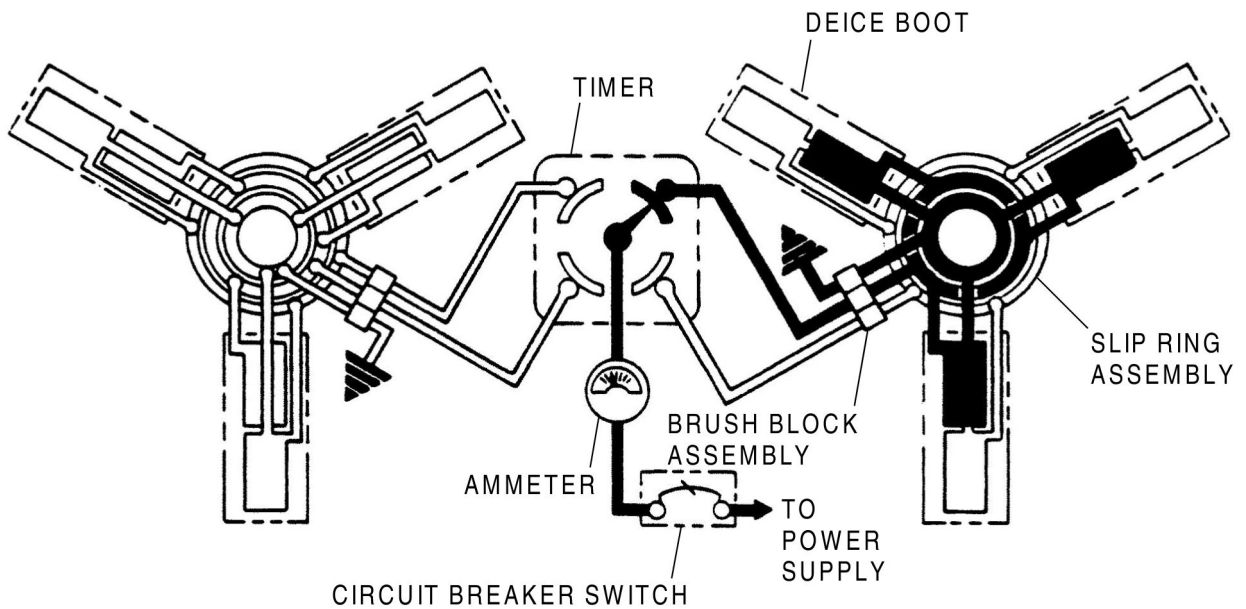

CYCLE 4

Dual Element, Twin Engine Cycle Sequence
Figure 6 (Sheet 2)

McCAULEY PROPELLER SYSTEMS
OWNER/OPERATOR
 INFORMATION MANUAL

C1857

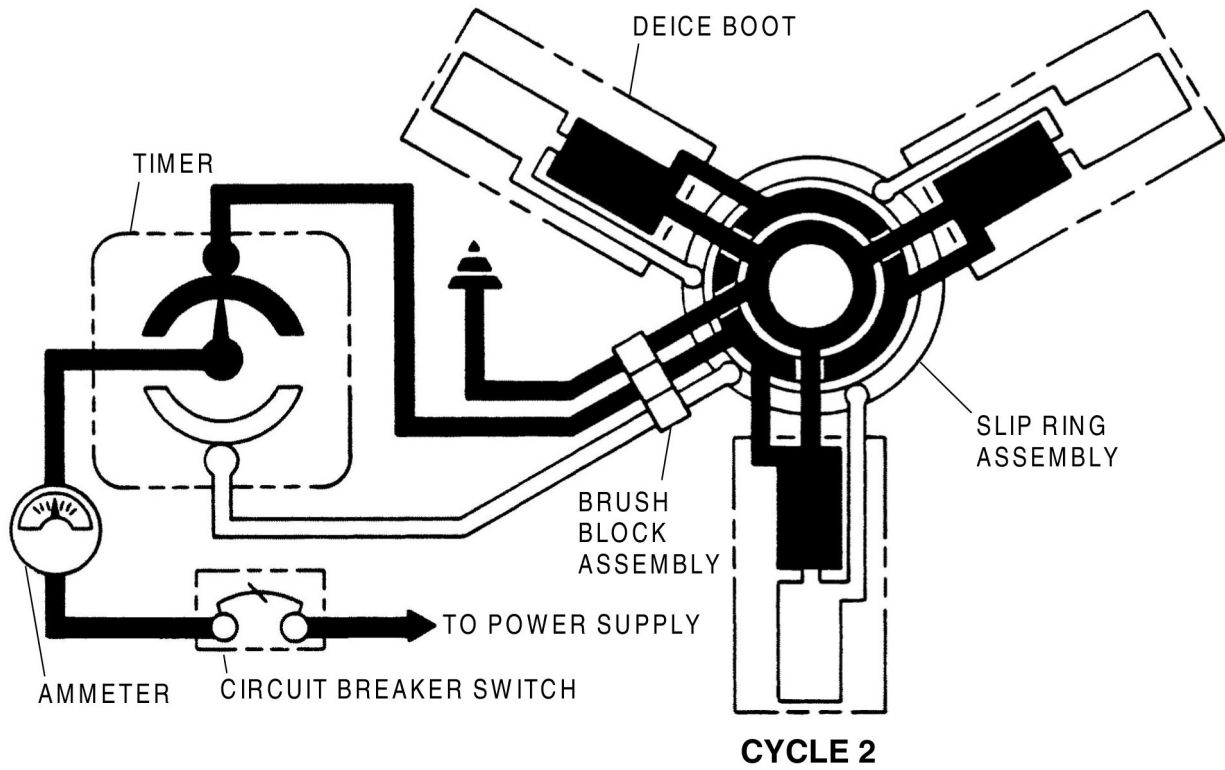
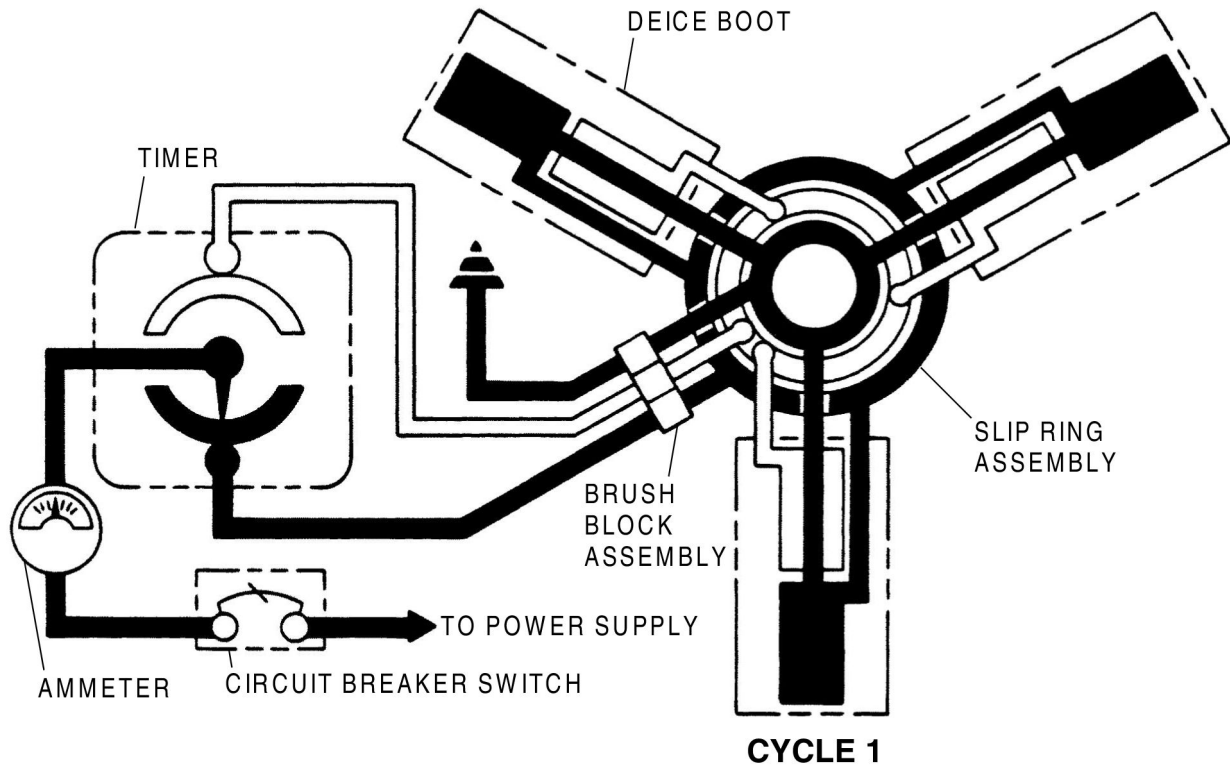

Dual Element, Single Engine Cycle Sequence
 Figure 7 (Sheet 1)

McCAULEY PROPELLER SYSTEMS
OWNER/OPERATOR
 INFORMATION MANUAL

C1858

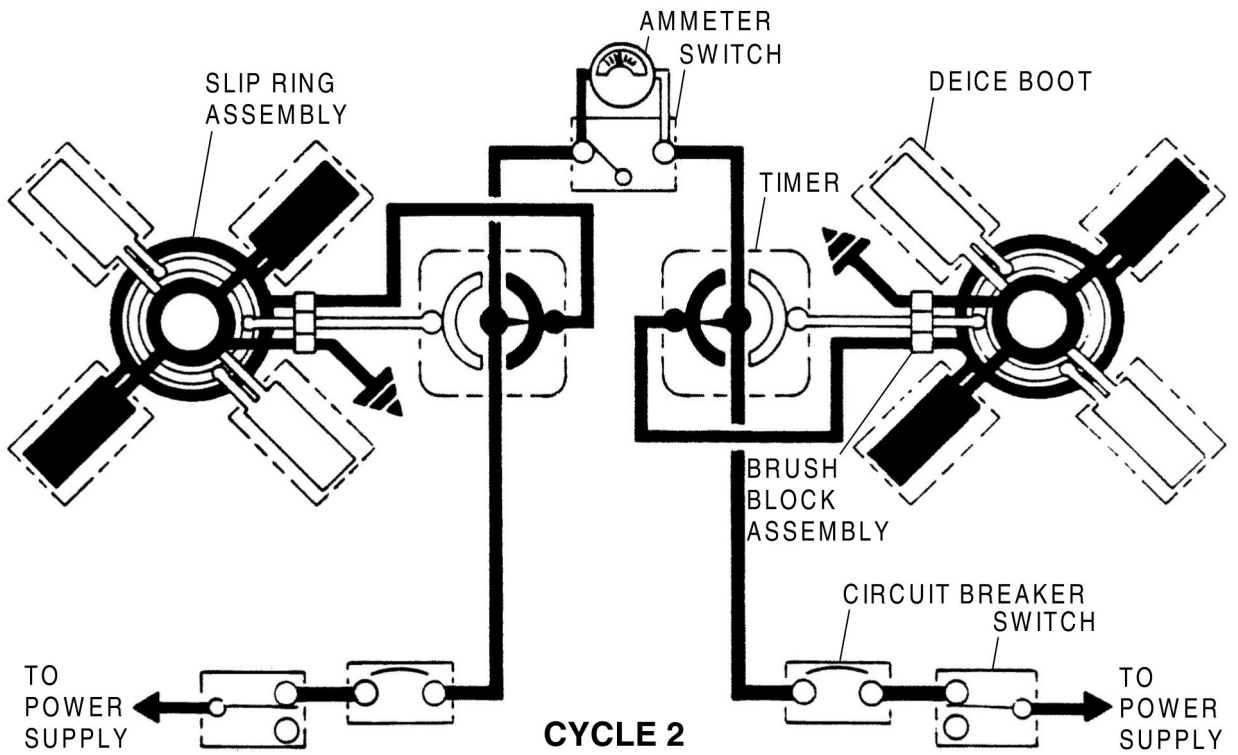
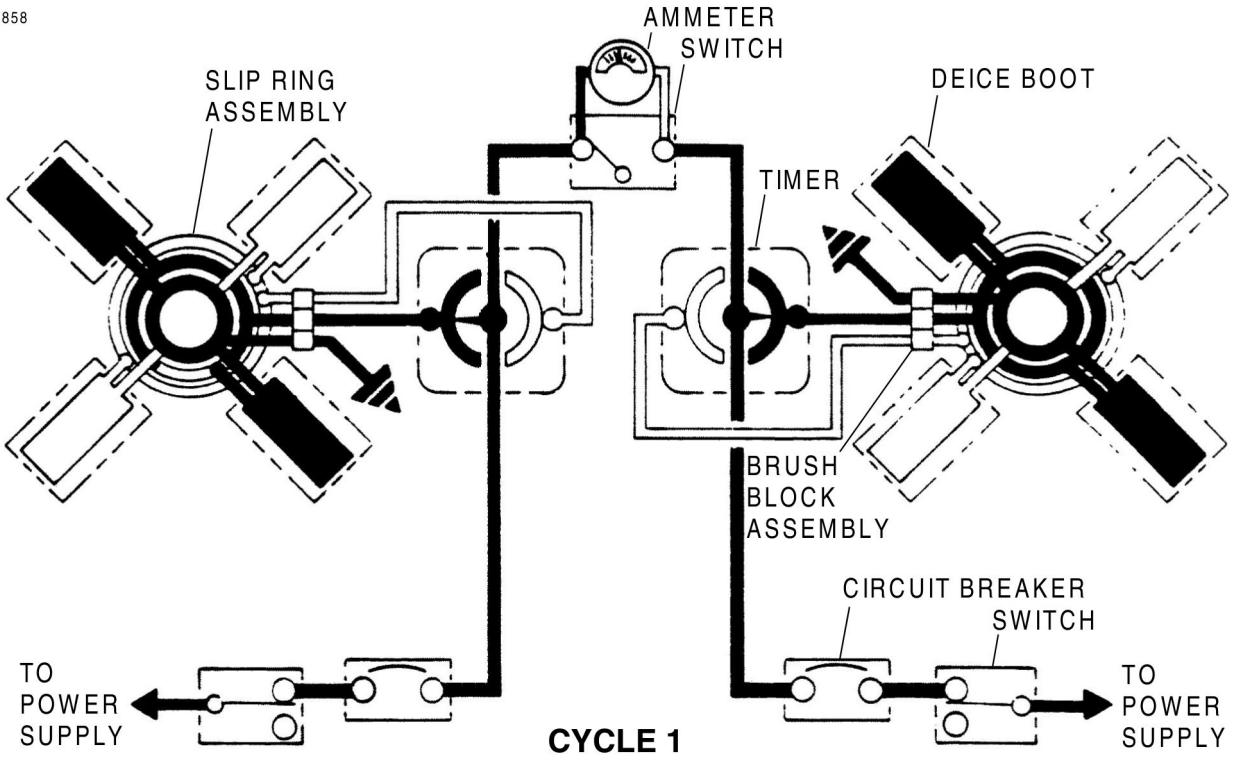

Single Element, Four Blade, Slow Turn Engine Cycle Sequence
 Figure 8 (Sheet 1)

McCAULEY PROPELLER SYSTEMS
OWNER/OPERATOR
INFORMATION MANUAL

(3) Dual element deice boots have three leads; one power input for each of the two separate heating elements, one common ground. To connect the deice boot to the slip ring assembly, boots are constructed with either an integral strap or with wire connectors at the base of the boot for detachable lead type wire harness.

B. Wiring Harnesses

(1) Deice boot wire harnesses are used with systems having detachable lead type deice boots in place of boots having integral lead straps. These wiring harnesses are used to carry electrical current from the slip ring assembly to the deice boot leads (refer to Figure 1).

C. Slip Ring Assemblies

(1) To carry electrical current to the deice boots, a slip ring assembly is used and rotates with the propeller assembly. Depending upon the specific aircraft, there are basically three different types of slip ring installations (refer to Figure 3):

(a) The slip ring is provided as a part of a starter ring gear assembly which has been modified to accept a bolt-on type slip ring assembly and replaces the original starter ring gear (utilized only on Lycoming engine applications).

(b) A pulley/slip ring assembly where the pulley is machined to accept the slip rings which become an integral part of the pulley. These pulley/slip ring assemblies are mounted between the propeller/engine flange and the back of the propeller (typically used where pulley is air conditioner and/or alternator drive).

(c) Separate slip ring assembly which is attached to the back of the propeller hub or mounts between the propeller/engine flange and the propeller.

1 For Pratt & Whitney engine installations, the slip ring assembly is mounted and supplied as part of the propeller assembly.

NOTE: On all McCauley two and three ring slip ring assemblies, the inner most ring is always ground.

D. Brush Block and Mounting Bracket Assemblies

(1) To carry electrical current to the rotating deice boots, a brush block assembly is mounted to the engine with a mounting bracket. This stationary brush block assembly contains two independently wired brushes for each ring of the rotating slip ring assembly. Two brushes are used for each ring of the slip ring assembly to provide system redundancy for this part of the propeller deice system.

E. Deice Timer

(1) The electrical deice timer directs current to each of the deice boot heating elements in a prescribed sequence for a specific amount of time. This sequence is repeated as long as the switch remains on. Refer to the applicable installation drawing in the McCauley Propeller Systems Application Guide for an illustration and current part numbers.

NOTE: McCauley has designed solid state deice timers. The solid state timers are direct replacements for the mechanical timers. Mechanical timers can continue in use until the stock of mechanical timers is depleted. On aircraft installations, which require the use of two (2) deice timers, it is permitted to use one (1) mechanical timer and one (1) solid state timer.

F. Ammeter

(1) Although shown on schematics and discussed throughout this manual, the ammeter is not supplied or manufactured by McCauley.

(2) The ammeter (when used in the system) indicates current flow to the deice boots. In the event of low battery voltage, which is possible during ground checks, the ammeter readings may be below the normal current range as described in Deice System Installation, Table 401. Problems in the system due to a faulty ammeter can be found by following the troubleshooting guide section of this manual (refer to Section 61-10-40 Troubleshooting). Also refer to instructions provided by the aircraft manufacturer or STC holder as applicable.

G. Switch or Circuit Breaker Switch

(1) Although shown on schematics and discussed throughout this manual, the switch, circuit breaker or circuit breaker/switch are typically not supplied by McCauley.

McCAULEY PROPELLER SYSTEMS
OWNER/OPERATOR
INFORMATION MANUAL

- (2) If the system current rises above the circuit breaker or circuit breaker switch limit, it will open (disengage) and cut power to the deice system. If tripped (disengaged), the circuit breaker must be reset manually. The circuit breaker/switch can be reset by turning it OFF then ON again. Problems in the system due to a faulty switch, circuit breaker, or circuit breaker/switch can be found by following the troubleshooting guide section of this manual (refer to Section 61-10-40 Troubleshooting). Also refer to instructions provided by the aircraft manufacturer or STC holder as applicable.

McCAULEY PROPELLER SYSTEMS
OWNER/OPERATOR
INFORMATION MANUAL

DEICE SYSTEM - TROUBLESHOOTING

1. Introduction

- A. Whether in flight or during ground checks, the ammeter can be used to determine the general nature of most electrical problems of the deice system. The troubleshooting chart is based, primarily, on the use of the ammeter and it is assumed that the user understands all normal operating modes of the deice system. Read all of the "trouble" entries to find the one matching the conditions of the system being checked. The "probable cause" and "remedy" entries pertinent to each trouble are arranged in the recommended checking sequence.

2. Helpful Hints

- A. The ammeter reading will be slightly lower than normal when the system is operated on airplane battery voltage only.
- B. Use the "heat test" to determine which propeller's deice boots are not operating. Refer to the applicable TC or STC maintenance information for a wiring schematic to trace the electrical circuits. These schematics are limited to the wiring between the timer and the deice boots. For the remaining system schematics refer to the applicable airplane manufacturer's service or maintenance manual.

CAUTION: The deice boots should not be operated continuously for more than five minutes under high ambient temperature, above 100° F (37.8° C), conditions without allowing them to cool down to ambient temperature.

(1) Heat Test.

- (a) With the deice switch ON, feel the deice boots on each propeller for the proper sequence of heater operation. Temperature rise should be noticeable and each heated element should warm while energized. Local hot spots indicate surface damage requiring replacement of the deice boot.

NOTE: To preserve the aircraft battery when making the ground checks, run a minimum number of cycles with the propeller in the static condition. Use of an auxiliary power supply is suggested for extended static testing of the deice boots.

- C. Excess current reading on the ammeter always indicates a power lead (+) is shorted to ground (-). When trouble of this nature is found, it is vital that the grounded power lead be located and corrected immediately.
- D. Inoperative wiring in the propeller mounted components may be indicated by normal current readings when the propellers are not rotating, but low current with the propellers rotating at normal cruise RPM. For this condition, do the following:
- (1) With the deice system switch "ON" and an assistant observing the ammeter, flex the lead straps or the wire harnesses of the deice boots which are operating. Any movement of the ammeter needle, other than the normal flicker from the timer cycling, indicates a short or open circuit that must be located and corrected. Check the continuity of wiring affected while flexing and prodding the suspected area.

3. Trouble Shooting Guide

- A. For the Trouble Shooting Guide, refer to Table 101.

McCAULEY PROPELLER SYSTEMS
OWNER/OPERATOR
 INFORMATION MANUAL

Table 101. Troubleshooting Guide

TROUBLE	PROBABLE CAUSE	CORRECTIVE ACTION
1. The ammeter indicates no current "flow" during all phases of the timer cycle.	A. No power from the aircraft.	If there is no voltage detected at the circuit breaker, locate and repair the open electrical circuit.
	B. Open circuit breaker.	Locate and correct the short to ground in the wiring before the circuit breaker is reset.
	C. Inoperative circuit breaker or switch.	Voltage to the electrical input side of the circuit breaker or switch but no voltage from the output side. Replace the inoperative switch or circuit breaker.
	D. Inoperative ammeter.	Follow the aircraft manufacturer's instructions.
	E. Electrical open to the timer.	Disconnect the electrical harness at the timer and check for voltage to ground on the appropriate harness input pin. See Section 61-10-40, Deice System Inspections, Table 601, Timer Operation Test for the input pin.
	F. Open between the timer and the deice brush blocks.	Disconnect the wire harness from the terminal strip located on the brush block mounting bracket. Check the voltage to ground from the appropriate leads (see applicable airplane service manual for power and ground lead identification). If low or no voltage, locate and correct the open or high resistance in the wire harness. Check for continuity from the appropriate lead to ground. If a high resistance is indicated, check the ground wire for breakage and the ground connections for security.
	G. Open in the deice boot or deice boot wire harness.	Disconnect the deice boot leads and check for resistance in accordance with Section 61-10-40, Deice System Installation, Deice Boot Installation (Final Electrical Check). If not correct, replace the deice boot. If correct, check for continuity of the deice boot wiring harness leads. The ohmmeter must not flicker when the leads are stretched or flexed. Replace as necessary.

McCAULEY PROPELLER SYSTEMS
OWNER/OPERATOR
 INFORMATION MANUAL

Table 101. Troubleshooting Guide (continued)

TROUBLE	PROBABLE CAUSE	CORRECTIVE ACTION
	H. Open on both ground brushes.	Remove the brush block assembly and check both ground brushes for continuity between the brush and pigtail lead. If an electrical open is found, repair the brush block assembly. If continuity is OK, install the brush block assembly and check for the proper face alignment and brush projection in accordance with Section 61-10-40, Deice System - Removal/Installation, Brush Block Assembly Alignment Requirements.
2. The ammeter indicates normal current for part of the cycle, 0 current for the remainder of the cycle.	A. Open in the wiring between the timer and the brush block assembly on one engine.	See 1.F.
	B. Open in the deice boot or deice boot wire harness.	See 1.G.
	C. Faulty timer.	Check in accordance with Section 61-10-40, Deice System Inspections, Timer Test.
	D. Faulty brush block assembly.	Check for broken brushes and test for opens (see 1.H.).
3. The ammeter indicates normal current for part of the cycle, low current for the remainder of the cycle.	A. The inboard and outboard deice boot heating elements are heating during the same phase (they are wired in series).	Locate and repair the incorrect lead connections.
	B. Open circuit or high resistance in the deice boot or deice boot wiring harness.	See 1.G.
	C. High resistance in the circuit with low current.	Check for contact of the brushes to the slip rings in accordance with Section 61-10-40, Deice System - Removal/Installation, Brush Block Assembly and Mounting Bracket Installation. Correct as necessary. Check the wiring from the timer to the deice boots for loose or corroded connections or partially broken wiring. Correct as necessary.

McCAULEY PROPELLER SYSTEMS
OWNER/OPERATOR
 INFORMATION MANUAL

Table 101. Troubleshooting Guide (continued)

TROUBLE	PROBABLE CAUSE	CORRECTIVE ACTION
4. The ammeter indicates low current for the entire cycle.	A. The aircraft voltage is low under normal operating conditions.	Check the voltage into the switch.
	B. Ammeter, switch, or circuit breaker faulty.	Check the voltage into and out of the ammeter, switch, and circuit breaker. If a voltage drop is found through any of these items, replace the defective component.
	C. High resistance up to the timer.	Check for partially broken wire or loose or corroded connection in the wiring between the aircraft power supply and the timer input.
	D. Faulty timer.	Test the timer in accordance with Section 61-10-40, Deice System Inspections, Timer Test.
	E. One deice boot heating element or wiring connection to the deice boot in each cycle is out.	Perform the heat test in accordance with Section 61-10-40, Deice System Inspections, 100 Hour Inspection, Deice Boots, Step 2.B.(6). Replace components that do not function correctly.
5. The ammeter indicates excess current over the entire cycle.	A. The power lead is shorted to ground.	Check the power leads from the ammeter to the deice boots for damage or arcing. Repair or replace as necessary.
	B. Faulty ammeter.	Repair or replace in accordance with the aircraft manufacturer's instructions.
6. The ammeter indicates normal current part of the cycle, excess current for the remainder of the cycle.	A. Short to ground or short between the timer and brush block.	Disconnect the leads at the brush block and timer and check for a short or ground. Repair as necessary.
	B. Short between the slip rings.	Clean the slip ring assembly thoroughly with MPK.
	C. Faulty timer.	Test the timer in accordance with Section 61-10-40, Deice System Inspections, Timer Test.
7. The ammeter does not "flicker" between the cycles.	A. Timer not grounded: timer not cycling.	Disconnect the harness at the timer and check ground connection with ohmmeter from the appropriate pin (see Section 61-10-40, Deice System Inspections, Table 601, Timer Operation Test).
	B. Timer contacts are welded together (caused by a short in the system).	Test the timer in accordance with Section 61-10-40, Deice System Inspections, Timer Test. If the timer is faulty, replace it with the correct part number after the short causing the original failure has been located and corrected.

McCAULEY PROPELLER SYSTEMS
OWNER/OPERATOR
 INFORMATION MANUAL

Table 101. Troubleshooting Guide (continued)

TROUBLE	PROBABLE CAUSE	CORRECTIVE ACTION
8. The ammeter "flickers" other than between the normal cycle periods (confirm by ground test in accordance with Section 61-10-40, Deice System Inspections, System Wiring).	A. Loose connection between the aircraft power supply and timer input.	Trace the wiring from the power source to the timer input. Make sure that good electrical contacts are made at each connection in the circuit.
	B. Loose or defective connections between the timer and deice boots.	If trouble occurs only part of the cycle, determine which deice boots are affected and check for rough or dirty slip rings causing the brush to skip. Also check circuits for loose or defective connections. If all of the deice boots on one prop are affected, check the ground circuit.
	C. The timer cycles erratically.	Test the timer in accordance with 7.A. and in accordance with Section 61-10-40, Deice System Inspections, Timer Test. If the timer is the cause of the fault, replace it with the correct part number timer.
9. Radio noise or interference with the deice system on.	A. Brushes are arcing.	Check the brushes for the proper face alignment and brush projection in accordance with Section 61-10-40, Deice System - Removal/Installation, Brush Block Assembly and Mounting Bracket Installation. Check for dirty or rough slip rings. If so, clean, machine, or replace the slip ring assembly in accordance with Section 61-10-40, Deice System Repair, Slip Ring Assembly.
	B. Loose connection.	See 8.A. and 8.B.
	C. Faulty switch or circuit breaker.	Place jumper wire across the switch or circuit breaker. If the noise disappears, replace the faulty switch or circuit breaker.
	D. Wiring is too close to the radio equipment or associated wiring.	Relocate the wiring. Follow the aircraft manufacturer's recommendations.
10. Cycling sequence is not correct.	A. Crossed connections between the timer and deice boots.	Check the system wiring for correct installation and condition of the wiring.
	B. Incorrect timer.	Install correct part number timer.

McCAULEY PROPELLER SYSTEMS
OWNER/OPERATOR
 INFORMATION MANUAL

Table 101. Troubleshooting Guide (continued)

TROUBLE	PROBABLE CAUSE	CORRECTIVE ACTION
11. Rapid brush wear or frequent breakage.	A. Brush block assembly is out of alignment.	Check the brushes for the proper face alignment and brush projection in accordance with Section 61-10-40, Deice System - Removal/Installation, Brush Block Assembly Alignment Requirements.
	B. Slip ring assembly wobbles.	Check the slip ring run-out with a dial indicator in accordance with Slip Ring Run-Out Test in this section.
	C. Rough slip ring surfaces.	Remachine in accordance with Section 61-10-40, Deice System Repair, Slip Ring Assembly.
	D. Dirty slip ring surfaces.	Clean slip ring with MPK.
	E. Brushes are arcing.	See 11.A.

McCAULEY PROPELLER SYSTEMS
OWNER/OPERATOR
 INFORMATION MANUAL

DEICE SYSTEM - REMOVAL/INSTALLATION

1. General

- A. Perform all installation/assembly procedures in a clean environment.
- B. Torque Values
 - (1) The following table provides the torque limits of McCauley fasteners used in deice assembly installations.

NOTE: Refer to the Illustrated Parts List for an illustration of the listed part. The item number in Table 401 refers to the same part as the index number from the Illustrated Parts List.

Table 401. Deice Assembly Torque Values

Propeller Model Series	Item Number	McCauley Part Number	Description	Torque Value	
				Inch-pounds	N-m
C500	126	A-1635-63, -202	Deice boot to bracket	8 to 10	0.9 to 1.1
C500	129	A-1639-19	Nut	8 to 10	0.9 to 1.1
C500	130	A-1635-14, 203	Deice clamp to bracket	30 to 36	3.4 to 4.0
C500	133	A-1639-51	Nut	30 to 36	3.4 to 4.0
C500	162	A-1639-3	Nut	50 to 70	3.4 to 4.0
C500	162	A-1639-38	Nut	12 to 15	1.3 to 1.7
C500	202	A-1635-126	Screw	20 to 25	2.2 to 2.8
C500	209	A-1635-36	Screw	12 to 15	1.3 to 1.7
C500	210	A-1635-76	Screw	72 to 84	8.1 to 9.5
C500	213	A-1635-40	Screw	12 to 15	1.3 to 1.7
C500	219	A-1635-63	Screw	8 to 10	0.9 to 1.1
C500	223	A-1635-56	Screw	12 to 15	1.3 to 1.7
C600	261	A-1635-148	Screw, terminal strip attachment	8 to 10	0.9 to 1.1
C600	262	A-1639-36	Nut, Terminal attachment	10 to 12	1.1 to 1.4
C600	265	A-1635-148	Screw, clamp to bracket	10 to 12	1.1 to 1.4
C600	275	A-1639-19	Nut, boot lead to bracket	8 to 10	0.90 to 1.13
C600	282	A-1635-19	Screw, clamp to bulkhead	20 to 25	2.3 to 2.8
C650	262	A-1635-146	Screw, terminal strip attachment	8 to 10	0.9 to 1.1
C650	264	A-1639-18	Nut, Terminal attachment	10 to 12	1.1 to 1.4

McCAULEY PROPELLER SYSTEMS
OWNER/OPERATOR
 INFORMATION MANUAL

Table 401. Deice Assembly Torque Values (continued)

Propeller Model Series	Item Number	McCauley Part Number	Description	Torque Value	
				Inch-pounds	N-m
C650	268	A-1635-14	Screw, clamp to bracket	10 to 12	1.1 to 1.4
C650	276	A-1639-53	Nut, boot lead to bracket	12 to 15	0.9 to 1.1
C650	280	A-1635-56	Screw, clamp to bulkhead	20 to 25	2.3 to 2.8
C650	285	A-1639-19	Nut, slip ring assembly	8 to 10	0.9 to 1.1
C650	286	A-1635-15	Screw, slip ring to hub attachment	30 to 36	3.4 to 4.1
C700	260	A-1635-146	Screw, terminal strip attachment	8 to 10	0.9 to 1.1
C700	262	A-1639-18	Nut, terminal attachment	10 to 12	1.1 to 1.4
C700	264A	A-1639-19	Nut, slip ring assembly	8 to 10	0.9 to 1.1
C700	266	A-1635-56	Screw, clamp/ bulkhead	20 to 25	2.3 to 2.8
C700	271	A-1635-14	Screw, clamp/bracket	10 to 12	1.1 to 1.4
C700	274	A-1635-63	Screw, boot lead/bracket	8 to 10	0.9 to 1.1
C700	283	A-1639-19	Nut	8 to 10	0.9 to 1.1
C750	260	A-1635-146	Screw, terminal strip attachment	8 to 10	0.9 to 1.1
C750	262	A-1639-18	Nut, terminal attachment	10 to 12	1.1 to 1.4
C750	264A	A-1639-19	Nut, slip ring assembly	8 to 10	0.9 to 1.1
C750	266	A-1635-56	Screw, clamp/ bulkhead	20 to 25	2.3 to 2.8
C750	271	A-1635-14	Screw, clamp/bracket	10 to 12	1.1 to 1.4
C750	274	A-1635-63	Screw, boot lead/bracket	8 to 10	0.9 to 1.1
C750	282	A-1639-19	Nut	8 to 10	0.9 to 1.1
C1100	112	A-1635-X	Screw (balance weight)	30 to 36	3.4 to 4.1
C1100	114	A-1635-5	Screw (deice mounting)	30 to 36	3.4 to 4.1
C1100	118	A-1639-18	Nut (Terminal attachment)	10 to 12	1.1 to 1.4
C1100	119	A-1639-53	Not (boot lead/bracket)	12 to 15	0.9 to 1.1
C1100	121	A-1635-14	Screw (clamp/bracket)	10 to 12	1.1 to 1.4

McCAULEY PROPELLER SYSTEMS
OWNER/OPERATOR
 INFORMATION MANUAL

Table 401. Deice Assembly Torque Values (continued)

Propeller Model Series	Item Number	McCauley Part Number	Description	Torque Value	
				Inch-pounds	N-m
C1100	130	A-1635-56	Screw (clamp/bulkhead)	20 to 25	2.3 to 2.8
C1100	133	A-1639-19	Nut (slip ring assembly)	8 to 10	0.9 to 1.1
C1100	135	A-1635-15	Screw (slip ring/hub attachment)	30 to 36	3.4 to 4.1
C1100	145	A-1635-36	Screw (bulkhead slip ring)	20 to 25	2.3 to 2.8
C1100	154	A-1635-146	Screw (terminal strip attachment)	8 to 10	0.9 to 1.1

NOTE 1: Torques are based on clean, dry, and undamaged threads. Damage may result if these torque values are used on lubricated threads.

2. Deice Boot Removal and Installation

A. General.

- (1) These instructions apply to all McCauley controllable propellers and describe the procedures to be followed for installation of electrothermal propeller deice boots on McCauley blades.

CAUTION: The condition of the propeller blades and the deice boot installation must comply with applicable FAA regulations. Inspect propeller blades prior to deice boot installation for any corrosion, cracks, dents, or nicks. If any defects are found, the blade must be repaired by an authorized McCauley propeller service facility prior to the installation of the deice boot. Check resistance of each heating element before installation of deice boots. Refer to Table 602 for deice boot resistance values.

NOTE: The airplane Type Certificate (TC) or propeller Supplemental Type Certificate (STC) information concerning deice boot installation shall always be consulted prior to installing a deice boot on a McCauley propeller. Airplane TC or propeller STC information takes precedence over the deice boot installation information in this manual.

- (2) All deice boots on a single propeller must be located the same distance from the center line of the propeller for rotational balance. The ("Y") dimension for the location of the deice boot is given in Table 402 and shown in Figure 401.

McCAULEY PROPELLER SYSTEMS
OWNER/OPERATOR
 INFORMATION MANUAL

Table 402. Aircraft and System Identification and Information

Aircraft Make and Model No.	Boot Part Number	Dim "X" See Note 3	Dim "Y" See Note 2	McCaugley Propeller Model No.	Notes See Note 1
Beech A36, B36TC, F33A, V35B	B-40245-53	0.375 inch (9.53 mm)	0.500 to 0.250 Inch (12.70 to 6.35 mm)	3A32C406 D3A32C409	3 blade propeller, integral leads, single engine, single element.
Beech 95-55, -A55, -B55, -B55A, -B55B	B-40245-52	--	0.480 to 0.00 Inch (12.19 to 0.00 mm)	3AF32C504	3 blade propeller, detachable leads, twin engine, one timer, single element deice boot. "
Beech C55, C55A, D55, D55A, E55, E55A	B-40245-52	--	0.500 to 0.250 Inch (12.70 to 6.35 mm)	3AF32C504	3 blade propeller, detachable leads, twin engine, one timer, single element deice boot.
Beech 58, 58A, E55, E55A	B-40245-52	--	0.500 to 0.250 Inch (12.70 to 6.35 mm)	3AF32C512	3 blade propeller, detachable leads, twin engine, one timer, single element deice boot.
Beech 58, 58P, 58PA, 58TC, 58TCA	B-40245-52	--	0.500 to 0.250 Inch (12.70 to 6.35 mm)	3AF32C511 3AF32C512	3 blade propeller, detachable leads, twin engine, one timer, single element deice boot.
Beech 58, 58P, 58PA, 58TC, 58TCA	B-40245-52	--	0.500 to 0.250 Inch (12.70 to 6.35 mm)	3AF32C521	3 blade propeller, detachable leads, twin engine, one timer, single element deice boot.
Beech 58, 58P, 58PA, 58TC, 58TCA	B-40183-18	--	0.500 to 0.250 Inch (12.70 to 6.35 mm)	3AF32C521	3 blade propeller, detachable leads, twin engine, dual element deice boots.
Beech A90, A90-1, A90-4, B90, C90 (LJ-502 thru LJ-583)	B-40245-52	--	0.500 to 0.250 Inch (12.70 to 6.35 mm)	4HFR34C763	4 blade propeller, detachable leads, twin engine, one timer, single element deice boots.
Beech C90 (LJ-584 and up), C90A, E90	B-40245-52	--	0.500 to 0.250 Inch (12.70 to 6.35 mm)	4HFR34C762	4 blade propeller, detachable leads, twin engine, one timer, single element deice boots.
Beech C90A	B-40245-56	--	0.500 to 0.250 Inch (12.70 to 6.35 mm)	4HFR34C768	4 blade propeller, detachable leads, twin engine, one timer, single element deice boots.
Beech 99, A99	B-40245-56	--	0.500 to 0.250 Inch (12.70 to 6.35 mm)	4HFR34C773	4 blade propeller, detachable leads, twin engine, one timer, single element deice boots.

McCAULEY PROPELLER SYSTEMS
OWNER/OPERATOR
 INFORMATION MANUAL

Table 402. Aircraft and System Identification and Information (continued)

Aircraft Make and Model No.	Boot Part Number	Dim "X" See Note 3	Dim "Y" See Note 2	McCaugley Propeller Model No.	Notes See Note 1
Beech 99, 99A, A99A, B99, C99	B-40245-56	--	0.500 to 0.250 Inch (12.70 to 6.35 mm)	4HFR34C769	4 blade propeller, detachable leads, twin engine, one timer, single element deice boots.
Beech 100, A100	B-40245-52	--	0.500 to 0.250 Inch (12.70 to 6.35 mm)	4HFR34C762	4 blade propeller, detachable leads, twin engine, two timers, single element deice boots.
Beech 100, A100	B-40245-56	--	0.500 to 0.250 Inch (12.70 to 6.35 mm)	5HFR34C1105	5 blade propeller, detachable leads, twin engine, one timer, single element deice boots.
Beech B200, B200C, B200T, B200CT	B-40245-50	--	1.250 to 1.000 Inch (31.75 to 25.40 mm)	3GFR34C702	3 blade propeller, detachable leads, twin engine, one timer, single element.
Beech B200, B200C (C-12F, UC-12M), B200CT, B200T	B-40245-56	--	1.250 to 1.000 inch (31.75 to 25.40 mm)	3GFR34C702	3 blade propeller, detachable leads, twin engine, one timer, single element.
Beech A200CT (RC-12K, RC-12L, RC-12N, RC-12P, RC-12Q)	B-40245-54	--	0.00 to 0.125 Inch (0.00 to 3.18 mm)	4JFR34C758	4 blade propeller, detachable leads, single element deice boots..
Beech B200, B200C, B200T, B200CT, B200C (C12F)	B-40245-52	--	0.500 to 0.250 Inch (12.70 to 6.35 mm)	4HFR34C754	4 blade propeller, detachable leads, twin engine, one timer, single element.
Beech B200, B200C (C-12F, C-12R), B200CT, B200T	B-40245-56	--	0.500 to 0.250 Inch (12.70 to 6.35 mm)	4HFR34C771	4 blade propeller, detachable leads, single element deice boots.

McCAULEY PROPELLER SYSTEMS
OWNER/OPERATOR
 INFORMATION MANUAL

Table 402. Aircraft and System Identification and Information (continued)

Aircraft Make and Model No.	Boot Part Number	Dim "X" See Note 3	Dim "Y" See Note 2	McCauley Propeller Model No.	Notes See Note 1
Beech 200, 200C, 200T, 200CT, A200C, A200CT, B200, B200C, B200C, B200T, B200CT, C-12D, C-12F, FWC-12D, RC-12D, UC-12B	B-40245-56	--	0.500 to 0.250 Inch (12.70 to 6.35 mm)	5HFR34C1008	5 blade propeller, detachable leads, single element deice boots.
Cessna T182T	B-40245-53	0.375 inch (9.53 mm)	0.438 to 0.312 Inch (11.13 to 7.92 mm)	B3D36C442	3 blade propeller, integral leads, single engine, single element.
Cessna 206H, T206H	B-40245-53	0.375 inch (9.53 mm)	0.500 to 0.250 Inch (12.70 to 6.35 mm)	B3D36C432	3 blade propeller, integral leads, single engine, single element.
Cessna 208, 208A, 208B	B-40245-54	--	0.375 to 0.250 Inch (9.53 to 6.35 mm)	3GFR34C703	3 blade propeller, detachable leads, single engine, one timer, single element deice boot.
Cessna 208, 208A, 208B	B-40245-54	--	0.500 to 0.250 Inch (12.70 to 6.35 mm)	4HFR34C775	4 blade propeller, detachable leads, single engine, one timer, single element deice boot.
Cessna T303	B-40183-19	--	0.480 to 0.00 Inch (12.19 to 0.00 mm)	3AF32C506 3AF32C507	3 blade propeller, detachable leads, twin engine, dual element. NOTE: Can also use the B-40183 -01 or B-40183-03 deice boot , but all three installed deice boots must be the same part number.
Cessna 300, 350	B-40245-60 (28V)(350) B-40245-61 Deice boot (14V)(300 and 350)	0.375 inch (9.53 mm)	0.438 to 0.312 Inch (11.13 to 7.92 mm)	D3A34C444	3 blade propeller, integral leads, single engine, single element.

McCAULEY PROPELLER SYSTEMS
OWNER/OPERATOR
 INFORMATION MANUAL

Table 402. Aircraft and System Identification and Information (continued)

Aircraft Make and Model No.	Boot Part Number	Dim "X" See Note 3	Dim "Y" See Note 2	McCaugley Propeller Model No.	Notes See Note 1
Cessna 400	B-40245-60 (28V)	0.375 inch (9.53 mm)	0.688 to 0.562 Inch (17.48 to 14.27 mm)	D3A34C447	3 blade propeller, integral leads, single engine, single element.
Cessna 310A, B, C, D, E, F, G, H, E310H, 310I, 310J-1	B-40183-19	--	0.480 to 0.00 inch (12.19 to 0.00 mm)	3AF32C528	3 blade propeller, detachable leads, twin engine, dual element.
Cessna 310J, K, L, N, E310J	B-40183-18	--	0.500 to 0.250 Inch (12.70 to 6.35 mm)	3AF32C512	3 blade propeller, detachable leads, twin engine, dual element.
Cessna 310P, Q	B-40183-19	--	0.480 to 0.00 inch (12.19 to 0.00 mm)	3AF32C504	3 blade propeller, detachable leads, dual element.
Cessna 310P, Q	B-40183-19	--	0.480 to 0.00 inch (12.19 to 0.00 mm)	3AF32C528	3 blade propeller, detachable leads, dual element.
Cessna 310R	B-40183-19	--	0.480 to 0.00 inch (12.19 to 0.00 mm)	3AF32C504	3 blade propeller, detachable leads, twin engine, dual element.
Cessna 310R	B-40183-19	--	0.480 to 0.00 inch (12.19 to 0.00 mm)	3AF32C528	3 blade propeller, detachable leads, twin engine, dual element.
Cessna 320D, 320E, 320F, 340, 340A, 401, 401A, 401B, 402, 402A, 402B, 402C, 414A	B-40183-19	--	0.480 to 0.00 inch (12.19 to 0.00 mm)	3AF32C504 3AF32C505	3 blade propeller, detachable leads, twin engine, dual element boots, one timer.
Cessna 404	B-40183-03	--	1.800 to 1.3 Inches (45.72 to 33.02 mm)	3FF32C501	3 blade propeller, detachable leads, twin engine, dual element. NOTE: The Y dimension is measured from the blade retaining ring.
Cessna 411, 411A	B-40183-19	--	1.800 to 1.3 Inches (45.72 to 33.02 mm)	3AF37C510	3 blade propeller, detachable leads, twin engine, dual element. NOTE: The Y dimension is measured from the blade retaining ring.

McCAULEY PROPELLER SYSTEMS
OWNER/OPERATOR
 INFORMATION MANUAL

Table 402. Aircraft and System Identification and Information (continued)

Aircraft Make and Model No.	Boot Part Number	Dim "X" See Note 3	Dim "Y" See Note 2	McCauley Propeller Model No.	Notes See Note 1
Cessna 414, 414A	B-40183-19	--	0.480 to 0.00 inch (12.19 to 0.00 mm))	3AF32C505	3 blade propeller, detachable leads, twin engine, dual element.
Cessna RAM 414-AW	B-40183-03	--	1.625 to 1.375 (41.28 to 34.93 mm)	3AF36C514	3 blade propeller, detachable leads, twin engine, dual element. NOTE: The Y dimension is measured from the blade retaining ring.
Cessna 421, A, B	B-40183-19	--	1.45 to 0.95 inch (36.82 to 24.13 mm)	3AF37C516	3 blade propeller, detachable leads, twin engine, dual element. NOTE: The Y dimension is measured from the blade retaining ring.
Cessna 421C	B-40183-03	--	1.800 to 1.3 Inches (45.72 to 33.02 mm)	3FF32C501	3 blade propeller, detachable leads, twin engine, dual element. NOTE: The Y dimension is measured from the blade retaining ring.
Cessna 425	B-40183-03	--	1.468 to 1.408 Inches (37.29 to 35.76 mm)	3GFR34C701	3 blade propeller, detachable leads, twin engine, dual element.
Cessna 425	B-40245-52	--	0.500 to 0.250 Inch (12.70 to 6.35 mm)	4HFR34C762	3 blade propeller, detachable leads, twin engine, single element.
Cessna 441	B-40183-03	--	1.468 to 1.408 Inches (37.29 to 35.76 mm)	3GFR34C601	3 blade propeller, detachable leads, twin engine, dual element.
Cessna 441	B-40245-56	--	0.500 to 0.250 Inch (12.70 to 6.35 mm)	4HFR34C661	4 blade propeller, detachable leads, twin engine, dual timers, single element.
DeHavilland DHC-6-300	B-40245-52	--	0.500 to 0.250 Inch (12.70 to 6.35 mm)	4HFR34C764	4 blade propeller, detachable leads, twin engine, single element.
Fairchild SA227-AC, -AT, -BC, -CC, -DC	B-40183-07	--	0.750 to 0.500 Inch (19.05 to 12.70 mm)	4HFR34C652	4 blade propeller, detachable leads, twin engine, single element.

McCAULEY PROPELLER SYSTEMS
OWNER/OPERATOR
 INFORMATION MANUAL

Table 402. Aircraft and System Identification and Information (continued)

Aircraft Make and Model No.	Boot Part Number	Dim "X" See Note 3	Dim "Y" See Note 2	McCaugley Propeller Model No.	Notes See Note 1
Jetstream J31	B-40183-07	--	0.750 to 0.500 Inch (19.05 to 12.70 mm)	4HFR34C652	4 blade propeller, detachable leads, twin engine, single element.
Jetstream J32	B-40183-55	--	0.750 to 0.500 Inch (19.05 to 12.70 mm)	4HFR34C653	4 blade propeller, detachable leads, twin engine, single element.
Jetstream J41	B-40183-16	--	1.275 to 1.025 Inch (32.39 to 26.04 mm)	B5JFR36C1101 B5JFR36C1103	(RH) 5 blade propeller, detachable leads, twin engine, dual element.
Jetstream J41	B-40183-17	--	1.275 to 1.025 Inch (32.39 to 26.04 mm)	C5JFR36C1102 C5JFR36C1104	(LH) 5 blade propeller, detachable leads, twin engine, dual element.
Mooney M20K	B-40245-57 Deice Boot (28V single element)	0.500 to 0.250 Inch (12.70 to 6.35 mm)	0.500 to 0.250 Inch (12.70 to 6.35 mm)	D3A36C430	3 blade propeller, detachable leads, twin engine, dual element.
Mooney M20K	B-40245-58 Deice Boot (14V dual element)	0.500 to 0.250 Inch (12.70 to 6.35 mm)	0.500 to 0.250 Inch (12.70 to 6.35 mm)	D3A36C430	3 blade propeller, detachable leads, single engine, dual element.
Mooney M20M	B-40245-53	0.500 to 0.250 Inch (12.70 to 6.35 mm)	0.500 to 0.250 Inch (12.70 to 6.35 mm)	B3D32C417	3 blade propeller, detachable leads, single engine, single element.
Mooney Rocket M20L, M, R	B-40183-19	--	0.480 to 0.00 inch (12.19 to 0.00 mm)	3AF32C525	3 blade propeller, detachable leads, single engine, dual element.
Piper PA-31, PA-31-325, PA-31-350	B-40245-56	--	1.45 to 1.20 Inch (36.82 to 30.48 mm)	B3DF36C526 B3DF36C527	3 blade propeller, detachable leads, single engine, single element. NOTE: The Y dimension is measured from the blade retaining ring.
Piper PA-31T, PA-31T1	B-40245-52	--	0.500 to 0.250 Inch (12.70 to 6.35 mm)	4HFR34C766	4 blade propeller, detachable leads, single engine, single element.
Piper PA-42, PA-42-720	B-40183-20	--	0.500 to 0.250 Inch (12.70 to 6.35 mm)	4HFR34C774	4 blade propeller, detachable leads, twin engine, dual element.

McCAULEY PROPELLER SYSTEMS
OWNER/OPERATOR
 INFORMATION MANUAL

Table 402. Aircraft and System Identification and Information (continued)

Aircraft Make and Model No.	Boot Part Number	Dim "X" See Note 3	Dim "Y" See Note 2	McCauley Propeller Model No.	Notes See Note 1
NOTE 1: Many McCauley propellers are provided to the aircraft manufacturer without the deice boots installed. In cases where the aircraft manufacturer installs the deice boots, or where non-McCauley deice boots are used, the appropriate aircraft manufacturer's service manual must be consulted for all installation information.					
NOTE 2: Deice Boot Restrainer Strap Location Dimension "X" (Inches) See Figure 401.					
NOTE 3: Deice Boot Location Dimension "Y" (Inches) See Figure 401 for boots with integral leads or Figure 402 for boots with detachable leads.					

- (3) On integral strap type deice boots a separate rubber restrainer strap is used at the inboard end of the boot to prevent loosening of the deice boot bond when centrifugal force acts on the lead strap. The procedure for installing the restrainer strap is given in Figure 401. The ("X") dimension for locating the restrainer strap is given in Table 402. The ("Y") dimension for location of integral strap type deice boots is given in Table 402 and shown in Figure 401.

B. Materials Required.

Table 403. Material Required for Deice Boot Installation

Name	Part Number	Manufacturer	Quantity
Restrainer Strap	B-40251	McCauley	1 each per propeller blade with an integral lead deice boot.
Rubber Adhesive	1300L	3M Company 3M Ctr Bldg 220-7W-03 Saint Paul, MN 55144-1000, Web: www.3m.com	
Sunbrite-Sterling Enamel Sealant	78-U-1003 with Catalyst U-1001-C	Sterling Lacquer Mfg. Co. 3150 Brannon Ave. St. Louis, MO 63139	As required
Fine Line Tape	218, 3/8 inch wide	3M Company	As required
Fine Line Tape	218, 1/2 inch wide	3M Company	As required
Fine Line Tape	218, 1 inch wide	3M Company	As required
Acid Brush	1/2 inch wide	Commercially available	As required
Paint Brush	3/4 inch wide	Commercially available	As required
Epoxy Cement	A-1664-29 (B-SY-QSA)	Pacer Technology 9420 Santa Anita Ave Rancho Cucamonga, CA 91730, Web: www.pacertechnology.com	For propeller blades that have an integral lead deice boot. One ounce tube 1/3 ounce required for each propeller blade.
Epoxy Cement	A-1664-30 SY-SS	Pacer Technology	One ounce tube 1/5 ounce required per blade

McCAULEY PROPELLER SYSTEMS
OWNER/OPERATOR
 INFORMATION MANUAL

Table 403. Material Required for Deice Boot Installation (continued)

Name	Part Number	Manufacturer	Quantity
	Bostik 1096M Adhesive	Bostik Findley, Inc. 211 Boston Street Middleton, MA 01949-2128 Phone: 978-777-0100, <u>Web:</u> www.bostik.com	NOTE: Bostik 1096M, is an adhesive for installing deice boots. It is an approved alternate adhesive for 1300L (McCauley P/N A-1664-15).
	Bostik 1007M Primer	Bostik Findley, Inc.	Primer for Bostick 1096M Adhesive
	Bostik #9R	Bostik Findley, Inc.	Curative agent for Bostick 1096M Adhesive
	Bostik 2402 Adhesive (Part A)	Bostik Findley, Inc.	NOTE: Bostik 2402 Adhesive, is an adhesive for installing deice boots. It is an approved alternate adhesive for 1300L (McCauley P/N A-1664-15).
	Bostik 9101 Adhesive (Part B)	Bostik Findley, Inc.	Part B shall be used with the Bostick 2402 Adhesive (Part A)
	Bostik 9252 Primer	Bostik Findley, Inc.	To prime metal parts prior to the application of the Bostick 2402 Adhesive.
Methyl n-Propyl Ketone (MPK)		Commercially available	
Toluol		Commercially available	Tackifying Solvent MPK may be used instead of Toluol to tackify cement. Toluol provides approximately 40 seconds of working time.
Cleaning cloth		Commercially available	Clean, lint-free cloth
2 inch rubber or wooden hand roller		Commercially available	To install deice boot

NOTE: Refer to Table 402 for deice boot part numbers and the airplane make and model number information. Airplane Type Certificate (TC) or Supplemental Type Certificate (STC) information shall always be consulted prior to installing a deice boot on a McCauley propeller. Airplane TC or STC information takes precedence over the deice boot installation information in this manual.

McCAULEY PROPELLER SYSTEMS
OWNER/OPERATOR
 INFORMATION MANUAL

C2351

CAUTION: MAKE SURE ALL DEICE BOOTS ON A GIVEN PROPELLER ARE LOCATED THE SAME DISTANCE FROM BLADE SHANK TO ASSURE ROTATIONAL BALANCE.

CAUTION: CENTER DEICE BOOT ON LEADING EDGE OF BLADE WITH INBOARD EDGE LOCATED AS SHOWN.

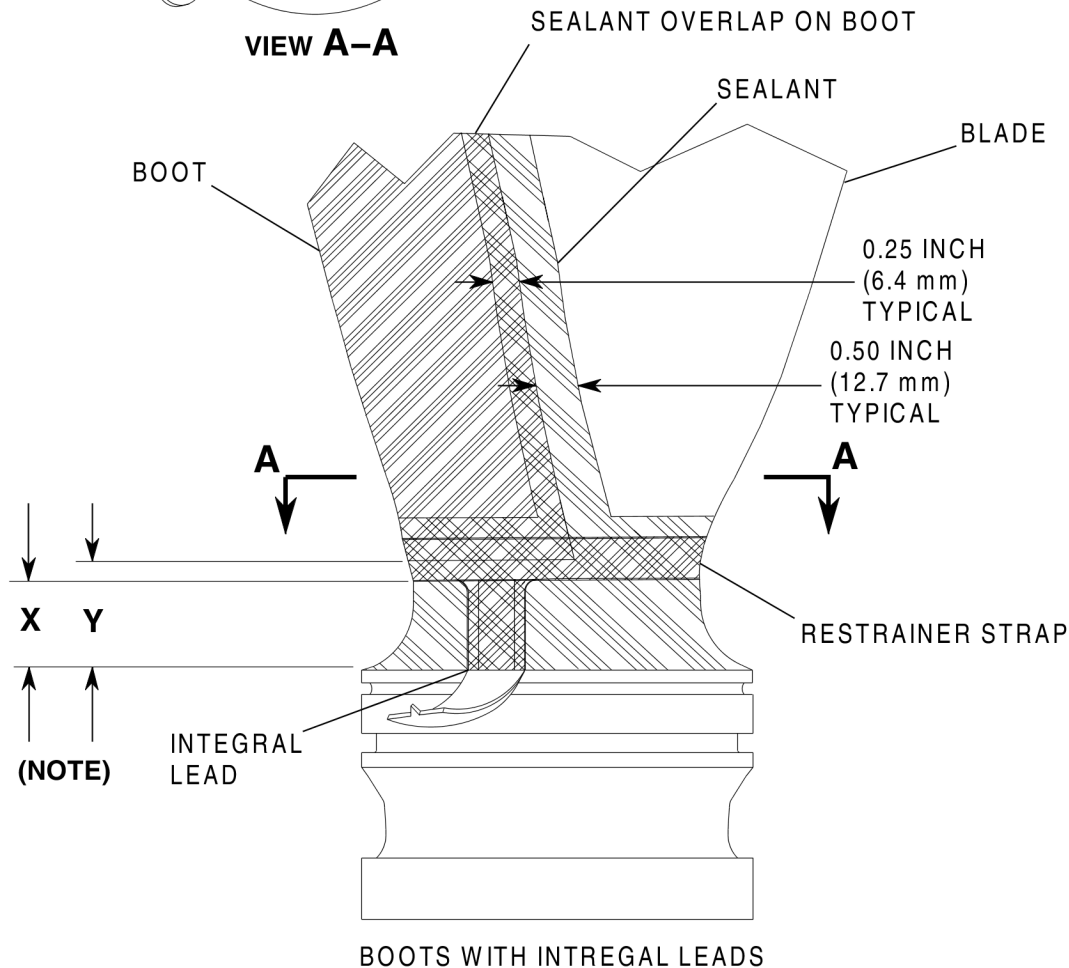
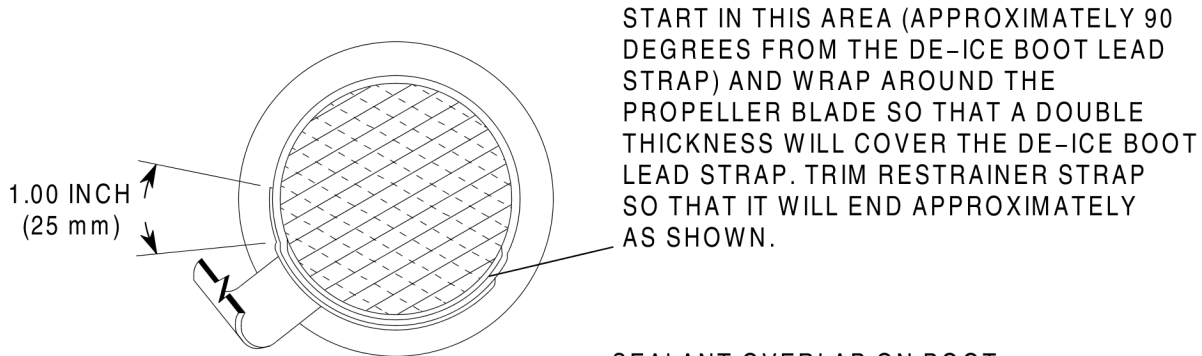

NOTE: REFER TO THE DEICE BOOT INSTALLATION PROCEDURES FOR DIMENSIONS X AND Y.

0101T1110

Restrainer Strap Installation (Used Only On Integral Lead Type Deice Boot)
 Figure 401 (Sheet 1)

McCAULEY PROPELLER SYSTEMS
OWNER/OPERATOR
INFORMATION MANUAL

C2352

CAUTION: MAKE SURE ALL DEICE BOOTS ON A GIVEN PROPELLER ARE LOCATED THE SAME DISTANCE FROM THE BLADE SHANK TO ASSURE ROTATIONAL BALANCE.

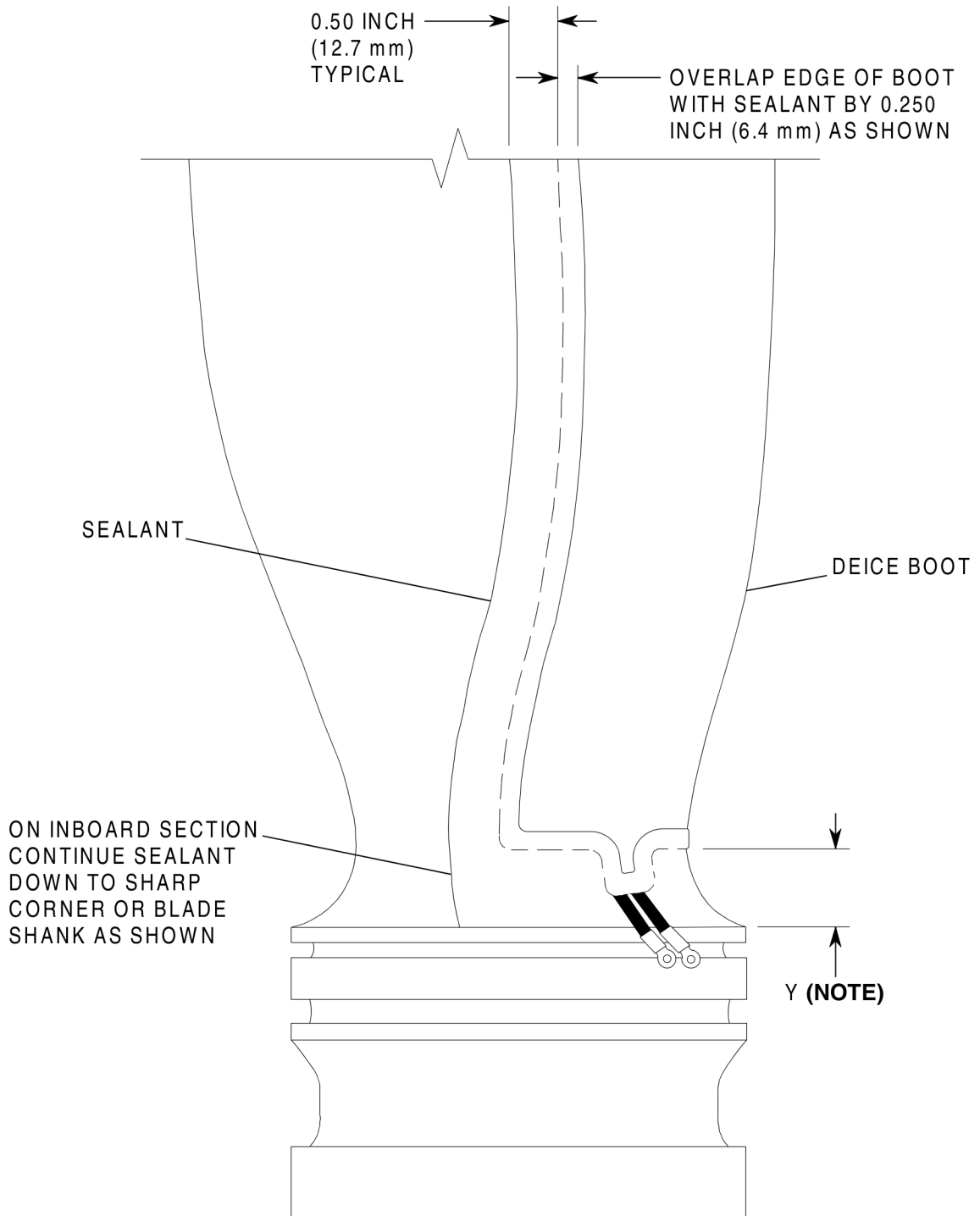

NOTE: REFER TO THE DEICE BOOT INSTALLATION PROCEDURES FOR DIMENSION Y.

0103T1007

Boot Location (Detachable Lead Type Deice Boot)
Figure 402 (Sheet 1)

McCAULEY PROPELLER SYSTEMS
OWNER/OPERATOR
INFORMATION MANUAL

C. Remove Propeller Deice Boot

WARNING: Cement and solvent vapors are toxic and extremely flammable. Use these chemicals only in a well ventilated area away from sparks and vapors. Excess exposure could cause injury or death. If dizziness or nausea occur, get to fresh air immediately. Avoid contact with skin or eyes. Use solvent-resistant gloves to minimize skin exposure. Use safety glasses to protect your eyes from chemicals. If you get chemicals in your eyes, flush your eyes with water for 15 minutes and see a physician immediately. If you get chemicals on your skin, wash thoroughly with soap and water. If you swallow chemicals, do not induce vomiting. See a physician immediately. Before work is started, always refer to the Material Safety Data Sheet (MSDS) for all chemicals used to remove and install the deice boot(s).

- (1) Cut the sta-straps and disconnect boot electrical leads as required.

NOTE: McCauley does not recommend the reinstallation of a deice boot that has previously been in service.

CAUTION: When removing boots from a complete propeller assembly, care must be taken to prevent solvent from leaking into the propeller hub and causing damage to the seals. The blade being worked on should be pointed down so all excess solvent will run to the outboard tip of the blade. As an extra precautionary measure, the hub and blade area should be masked. Do not use any sharp objects which might scratch the propeller blade when removing the boot.

- (2) Using methyl n-propyl ketone or toluol to soften the adhesion line between the deice boot and propeller blade, start at one corner, loosen enough of the boot to grasp with vise grips, pliers, or similar tool.

CAUTION: Do not use any sharp object which might scratch the surface of the propeller blade.

- (3) Apply a steady pull to remove the boot; pull the boot from the blade slowly and carefully while continuing to use a liberal amount of methyl n-propyl ketone or toluol to soften the adhesion line.
- (4) Remove all residual cement, edge sealer and epoxy from the blade. Use solvents with caution as mentioned above.
- (5) Visually inspect the propeller blades for damage or deterioration before the replacement boot is installed. Check for any corrosion, cracks, dents, or nicks. If any damage is found, the blade must be repaired by an authorized propeller repair station before the deice boot can be installed.

D. Blade Preparation

- (1) Refer to Table 402 for the ("Y") dimension for proper location of the applicable deice boot on the hub side of the propeller blade.
- (2) Outline the area to be masked using a red pencil (non-graphite marker). Area may be marked off using a template or by hand fitting a deice boot to the blade. Deice boots that use an integral type lead strap must be marked for lead strap alignment. Deice boots with detachable leads must be aligned with the installed propeller blade shank terminal bracket (refer to Figure 401 and Figure 402).

McCAULEY PROPELLER SYSTEMS
OWNER/OPERATOR
INFORMATION MANUAL

- (3) Align deice boot with the lead strap marks and center the outboard portions of the deice boot on the leading edge of the propeller blade. Once the deice boot is positioned, mark an area 0.5 inch outside of the boot perimeter. Using fine line tape, mask around this outline.

NOTE: Make sure to position the boot so that boot leads (with screws, washers, and insulators attached) will be properly aligned with de-ice lead brackets.

- (4) On blades painted with lacquer, remove all paint within the masked off area. In addition, when a rubber restrainer strap will be used, remove paint and clean around entire blade 2 inches from the propeller hub. On blades painted with polyurethane, lightly sand within the masked off area using 400 grit sandpaper. Clean entire masked area thoroughly with MPK or acetone. For final cleaning, quickly wipe off solvent with a clean, dry, lint-free cloth to avoid leaving a film.
- (5) Apply a second layer of masking tape to cover an additional 0.125 inch (3.18 mm) **inside** of the previously masked area.

E. Preinstallation Electrical Check

- (1) Check the electrical resistance between the ground lead ("G") and inboard lead ("I") then the ground ("G") and the outboard ("O") lead of a dual element boot. Check resistance between the ground lead ("G") and the positive lead ("I") of a single element boot. Make sure that the resistance values are between the values listed in Table 602 for that particular deice boot part number.
- (2) Check for intermittent open circuits by tensioning the deice boot leads and/or strap slightly while measuring resistance. Also, press lightly on the entire deice boot heating element surface and in the area adjacent to leads. Resistance must not fluctuate. This check is important because an intermittent open circuit may not show up until the propeller is rotating.

F. Deice Boot Adhesive Application

CAUTION: Cleanliness of metal and rubber parts cannot be overemphasized. Only very clean surfaces will assure maximum adhesion.

- (1) Moisten a clean cloth with MPK or acetone. Clean the unglazed (back) surface of the deice boot and surfaces of the restrainer strap (if used). Change the cloth frequently to avoid contamination of the clean area.
- (2) Thoroughly mix the 1300L adhesive.

NOTE: To prevent curling of the deice boot edges, apply fine line tape to the edges on the smooth side before applying adhesive to the fabric impressed side. Remove tape from the deice boot before starting installation.

- (3) For best results, apply cement and make deice boot installation at room temperature (65 °F to 75° F or 18.3° C to 23.9° C) Apply one, even, brush coat of adhesive to the clean, masked surface of the propeller blade and the fabric impressed side of the deice boot. Also, when installing an integral lead strap type deice boot apply adhesive to the deice boot lead strap so that strap will be cemented to the blade. Allow cement to air dry for a minimum of one hour at 40° F (4.4° C), or above, when the relative humidity is less than 75%. If the humidity is 75% to 90%, additional drying time will be required to cure adhesive. Do not apply adhesive if relative humidity is higher than 90%. After the adhesive is dry (not tacky), apply a second, even, brush coat of adhesive to the deice boot.
- (4) Apply an even brush coat of adhesive on the clean, masked off surface of the propeller blade immediately after the second coat of adhesive has been applied to the deice boot. Timing is important because the adhesive on both surfaces must reach the tacky stage at the same time.

G. Installing Deice Boot

- (1) When the adhesive coats are tacky dry on both blade surface and deice boot surface, locate deice boot leads with lead strap with alignment marks previously made. Tack the deice boot center line to the leading edge of the blade, starting at the inboard end working toward the tip. If the adhesive dries, use the tackifying solvent as necessary. If the deice boot is allowed to get off course, pull up with a quick motion and reapply boot. If adhesive is removed from either

McCAULEY PROPELLER SYSTEMS
OWNER/OPERATOR
INFORMATION MANUAL

surface, completely remove the boot and reapply adhesive. Use tackifying solvent as necessary to reinstall the boot. When correctly positioned, press firmly with rubber or wooden hand roller along full length of propeller blade leading edge to form a tight bond.

NOTE: When installing the deice boot, make sure to position the boot so that boot leads (with screws, washers, and insulators attached) will be properly aligned with the de-ice brackets.

- (2) Gradually tilt the roller over to either side of the leading edge contour to avoid trapping air. Roll from leading edge of blade toward the trailing edge. Work a small section at a time, starting at the inboard section of the blade and work towards the tip. Work all excess boot material out to perimeter before moving to the next section. If excess material at boot edges tends to lift the edges of the boot away from the surface of the blade, use your fingers to carefully work the lifted areas smooth.
- (3) Remove the masking tape that was installed as a second layer of masking tape to cover an additional 0.125 inch (3.18 mm) **inside** of previously masked area marking the 0.5 inch (12.7 mm) boot perimeter.

NOTE: For boots with integral deice boot leads, do not apply the edge sealer until after the boot restraining strap is installed.

- H. Remove any excess 1300L adhesive from the blade in the area surrounding the installed deice boot.
- (1) Use a cloth dampened with Methyl n-Propyl Ketone (MPK) to wipe off the excess adhesive.

I. Final Electrical Check

- (1) Check the electrical resistance between the ground lead ("G") and inboard lead ("I") then the ground ("G") and the outboard ("O") lead of a dual element boot. Check resistance between the ground lead ("G") and the positive lead ("I") of a single element boot. Make sure that the resistance values are between the values listed in Table 602 for that particular deice boot part number.
- (2) Check for intermittent open circuits by tensioning the deice boot leads and/or strap slightly while measuring resistance. Also, press lightly on the entire deice boot heating element surface and in the area adjacent to leads. Resistance must not fluctuate. This check is important because an intermittent open circuit may not show up until the propeller is rotating.

NOTE: This electrical check of the deice boot is accomplished again after it is installed on the propeller blade to make sure that the heating element was not damaged during installation.

J. Restrainer Strap Installation.

- (1) Apply 0.5 inch (13 mm) wide fine line tape to the blade to shank intersection.
 - (a) Make sure the tape extends onto the painted surface of the blade approximately 0.18 inch (4.8 mm).
- (2) Determine the correct position of the restrainer strap as defined by dimension "X" and "Y".

NOTE: On integral lead strap type deice boots a separate rubber restrainer strap is used at the inboard end of the boot to prevent loosening of the deice boot bond when centrifugal force acts on the lead strap. The procedure for installing the restrainer strap is given in Figure 401. The ("X") dimension for locating the restrainer strap is given in Table 402. The ("Y") dimension for location of integral lead strap type deice boots is given in Table 402 and shown in Figure 401.

- (a) Apply fine line tape approximately 0.18 inch (4.8 mm) outboard of the outboard edge of the restrainer strap position.
- (3) Thoroughly clean the area between the fine line tape with a cloth dampened with MPK.
- (4) Clean the under surface of the restrainer strap.

McCAULEY PROPELLER SYSTEMS
OWNER/OPERATOR
INFORMATION MANUAL

- (5) Apply 1300L adhesive to the inner surface of the restrainer strap and to the area between the fine line tape and allow to dry for approximately 15 minutes.

NOTE: Do not apply adhesive closer than 0.25 inch (6 mm) to the fine line tape on the blade shank.

- (a) Make sure the adhesive is dry, not tacky.
(6) Apply a second coat of adhesive to the blade and strap.
(7) Immediately install the strap in the correct location.
(a) Allow the adhesive to thoroughly dry (approximately 15 minutes) and make sure the restrainer strap is secure.
(8) Remove any excessive adhesive with a cloth dampened with MPK.
(9) Epoxy Adhesive Application

NOTE: Read the following instructions carefully before you begin the epoxy application.

NOTE: Do not attempt to mix more epoxy than is required for one blade.

- (a) Mix approximately 1/3 tube (0.333 ounce or 9.8 ml) of epoxy A-1664-29 epoxy or 0.2 ounce (5.9 ml) of A-1664-30 epoxy.
(b) Use an acid brush to quickly apply a thin coat of the epoxy from the outboard fine line tape, inboard through the inboard adhesive line remaining from the restrainer strap installation.

NOTE: The A-1664-29 epoxy will begin to set very quickly (approximately 3 minutes from mixing), and therefore must be applied as quickly as possible.

NOTE: The A-1664-30 epoxy has an approximate 30-minute cure time.

- 1 The epoxy does not need to extend all the way to the fine line tape at the blade shank.
2 The epoxy is applied only from near the shank to just outboard of the restrainer strap. Make sure the entire restrainer strap is covered in epoxy.
(c) Do not "over brush" the epoxy. Brushing the partially cured epoxy will produce brush marks.
(d) Immediately after the epoxy is applied, remove the outboard fine line tape. Do not remove the tape applied for application of the edge sealant enamel.
(e) Allow the epoxy to cure.
1 Allow 10 minutes for A-1664-29 epoxy.
2 Allow 60 minutes for A-1664-30 epoxy.
(f) Properly dispose of the acid brush immediately. Do not try to reuse the acid brush on another blade.

K. Application of Sealer

- (1) Mixing of Materials. Mix two parts of Sunbrite 78-U-1003 or 78A-1003 brushable black enamel with one part enamel catalyst U-1001-C.

CAUTION: It is imperative that the masking steps, as described in Blade Preparation steps be followed. This will make sure that the sealer will be applied to both the adhesive and 0.125 inch (3.175 mm) of bare metal. If the adhesion line and the sealer line start at the same point water will be allowed to seep underneath the adhesion line, resulting in an ineffective seal of the deice boot.

- (2) Remove the fine line tape from the blade (leave the tape on the boot) that was used when you applied the adhesive, but do not remove the tape that was applied approximately 0.5 inch (13 mm) outside the perimeter of the boot.

NOTE: For deice boots that use a restraining strap, do not apply the sealer until the restraining strap is installed.

McCAULEY PROPELLER SYSTEMS
OWNER/OPERATOR
INFORMATION MANUAL

- (3) For deice boots that use a restraining strap, apply the fine line tape approximately 0.12 to 0.25 inch (3 to 6 mm) outboard of the outboard edge of the epoxy cement.
- (4) Trim all tape as necessary to allow a continuous band around the boot.
- (5) Use a 0.75 inch (19 mm) brush to apply the enamel sealant around the edges of the boot, the entire restrainer strap (if installed), and to the fine line tape at the blade shank.
 - (a) Applying Sealer. Apply one, even, brush coat of sealer to the area around the boot. Make sure the sealer covers the propeller blade bare metal and adhesive as described above along with a masked off area of 0.250 inch (6.4 mm) of the deice boot itself. Remove masking tape as sealer is brushed on, otherwise, sealer will pull up along with the tape. Allow sealer to dry. (Refer to Figure 401 and Figure 404.)

L. Curing Time

- (1) Allow the sealant enamel to dry for at least one hour at 65 to 75° F (18 to 24° C) before you handle the deice boot and strap area. For deice boots on an installed propeller, the deice boot must be allowed to cure a minimum of 12 hours before starting the engine and 24 hours before actually operating the deice system.

3. Slip Ring Installation

A. General

CAUTION: These instructions are not applicable to C700, C750, or C1000 model series propellers. To remove or install a slip ring on a C700, C750, or C1000 model series propeller will require adjustment of the propeller beta rods. Beta rod adjustment shall only be accomplished by an FAA-approved or international equivalent propeller repair station by qualified personnel.

NOTE: The airplane Type Certificate (TC) or Supplemental Type Certificate (STC) information concerning slip ring installation shall always be consulted prior to installing a slip ring on a McCauley propeller. Airplane TC or STC information takes precedence over the slip ring installation information in this manual.

- (1) McCauley manufactures different types of slip rings for various propeller installations (refer to Section 61-10-40, Deice System Description, Deice Systems, Figure 3):
 - (a) Slip Ring Assembly
 - 1 The slip ring assembly is factory installed/mounted and supplied as part of the propeller assembly (C700, C750, or C1000 model series propellers/Pratt & Whitney engine installations).
 - 2 A separate slip ring assembly which is attached to the back of the propeller hub or mounts between the propeller/engine flange and the back of the propeller hub.
 - (b) Pulley/Slip Ring Assembly
 - 1 A pulley/slip ring assembly in which the pulley is machined to accept the slip rings that become an integral part of the pulley. These pulley/slip ring assemblies are mounted between the propeller/engine flange and the back of the propeller hub. (Typically used where the pulley is air conditioner and/or alternator drive.)
 - (c) Starter Ring Gear/Slip Ring Assembly
 - 1 The slip ring is provided as a part of a starter ring gear assembly which has been modified to accept a bolt-on type slip ring assembly and replaces the original starter ring gear. (Utilized only on Lycoming engine applications.)

McCAULEY PROPELLER SYSTEMS
OWNER/OPERATOR
INFORMATION MANUAL

B. Installing Slip Ring Assembly

NOTE: All slip ring assemblies manufactured by McCauley, with the exception of the starter ring gear type, have an etched scribe line for correct orientation of the assembly. This scribe line will appear on either face surface of the aluminum platter of the assembly (either slip ring side or terminal stud side) and will start at the outside diameter and run toward the center line of the assembly (approximately 0.25 inch (6.35 mm) long). In all cases the slip ring assembly should be orientated so that this line falls directly on the center line of a propeller blade. Refer to the aircraft manufacturers Type Certificate (TC) or the propeller Supplemental Type Certificate (STC) for procedures and orientation of starter ring gear type assemblies (refer to Section 61-10-40, Deice System Description, Deice Systems, Figure 3).

- (1) Place the slip ring assembly on propeller mounting studs or propeller hub and orientate the assembly so that the scribe line, as described in the preceding note, falls in line with a propeller blade. On applications which the slip ring is attached to the back of the propeller hub, first attach the slip ring assembly to the spinner bulkhead assembly, making sure to orientate as described above. Attach with screws and washers provided. Torque screws and lockwire heads as required.
- (2) Next, secure the slip ring assembly (with spinner bulkhead attached) to the propeller hub with screws and washers provided and again orientate as described in the preceding note.

CAUTION: Do not, under any circumstances, shim any McCauley slip ring assemblies to change or correct slip ring run-out. To check run-out of used slip rings and methods of correction, refer to Section 61-10-40, Deice System Repair, Slip Ring Assembly in this manual.

- (3) All McCauley slip rings are precision machined for correct face runout from the same surface of which they will be installed on the propeller. Therefore, it is not necessary to check run-out of the slip ring surfaces after installation.

4. **Brush Block Assembly and Mounting Bracket Installation**

A. Mounting Bracket Installation

- (1) Install mounting bracket to engine with bolts, washers, nuts, and spacers (if required) in sequence as shown in the applicable Illustrated Parts List in this manual or in the airplane TC or STC maintenance information.
- (2) On installations where the mounting bracket is installed to the front engine case studs, existing nuts are to be used to secure the bracket. Torque the fasteners in accordance with applicable airplane or engine manual.

B. Brush Block Assembly Installation

NOTE: Installation of the brush block assembly should be deferred, where possible, until after the slip ring assembly, pulley/slip ring assembly, or starter ring gear/slip ring assembly, propeller and related components are installed. However, installation of the mounting bracket can be made more conveniently before the installation of these components to the engine.

CAUTION: To avoid breakage, keep brushes retracted in brush block until slip ring, starter ring gear/slip ring, or pulley/slip ring and propeller assemblies have been installed.

- (1) Attach brush block assembly, spacers, and shims (thin washers) to the mounting bracket with the two screws and washers provided. Locate the brush block on the mounting bracket using care not to exert any side loads on the brushes which may cause breakage. Secure, but do not tighten the two mounting screws at this time.

McCAULEY PROPELLER SYSTEMS
OWNER/OPERATOR
INFORMATION MANUAL

C. Brush Block Assembly Alignment Requirements

- (1) In order to get smooth, efficient and quiet transfer of electrical current from the brushes to the slip rings, brush alignment must be checked and adjusted, if necessary, to meet two requirements:
 - (a) Brush Projection. Projection must be such that the distance between the brush holder and the face of the slip rings is 0.064 inch, +0.015 or -0.015 inch, through 360 degrees of slip ring rotation.
 - (b) Face Alignment. The brushes must be lined up with the slip rings so that the entire face of each brush is in contact with the slip ring throughout the full 360 degrees of slip ring rotation (refer to Figure 403).

D. Brush Block Alignment Methods

- (1) Brush Projection. Brush projection can be adjusted by loosening the two screws attaching the brush block assembly to the mounting bracket and holding the brush block in the designated position while retightening the screws. Slotted holes are provided in the mounting bracket for this purpose. Torque screws in accordance with the applicable installation drawing in the McCauley Propeller Systems Application Guide.
- (2) Face Alignment. Face alignment of the brushes must be adjusted by removing the two screws that hold the brush block to the mounting bracket. Add or remove the thin washers (shims) under each spacer as required to correct alignment. Reinstall screws and lockwire screw heads. Torque screws in accordance with the applicable installation drawing in the McCauley Propeller Systems Application Guide.
- (3) Testing Alignment. When a chattering or screeching noise is emitted from the brush/slip ring area, the probable cause is the improper alignment of the brush block and slip ring assemblies.

NOTE: Chattering or screeching may be detected by pulling each propeller through slowly in the direction of rotation and should be corrected immediately. If this chattering or screeching noise is noticed over idling engine noises, the trouble is severe and should also be corrected immediately. As a general rule, engines should be run for one hour before energizing the deice system. This will ensure proper seating of the brushes to the slip rings and prevent any arcing which could cause radio noise or rapid wear of the brushes.

5. Wiring Harness Or Lead Strap Installation

- A. General. There are basically two methods of transferring electrical current from the slip ring assembly to the deice boots.
 - (1) With a detachable lead type deice boot a separate wiring harness is used to transfer electrical current from the slip ring to the deice boot.
 - (2) On installations using integral lead type deice boots the lead strap of the boot is attached directly to the slip ring assembly.
- B. Installing Wire Harness (Detachable Lead Type Boot)
 - (1) First attach wiring harness leads to the deice boot lead mounting bracket with hardware provided as shown in Figure 404.
 - (a) For wire harnesses that use a mechanical clamp as shown in Figure 404, make certain that harnesses are located in the clamp so that the shoulder of the molded rubber portion of the harness is against the side of the clamp.
 - (b) For wire harnesses that do not use a mechanical clamp as shown in Figure 406, make certain that the wire harnesses are captured by the tie straps as shown.

NOTE: Proper security of the wire harness at the deice boot lead mounting bracket will help prevent damage to the harness due to centrifugal force.

McCAULEY PROPELLER SYSTEMS
OWNER/OPERATOR
INFORMATION MANUAL

C1860

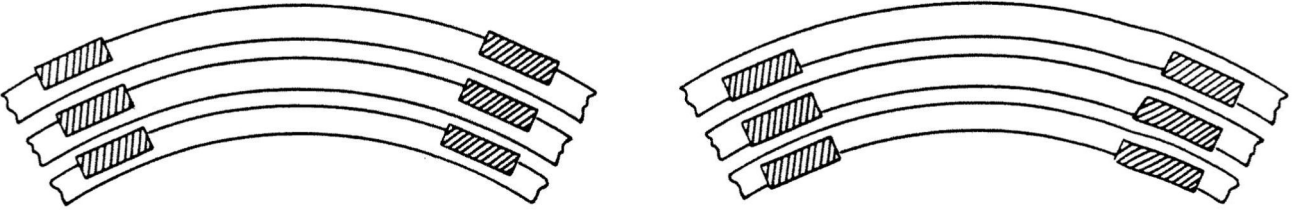

INCORRECT FACE ALIGNMENT

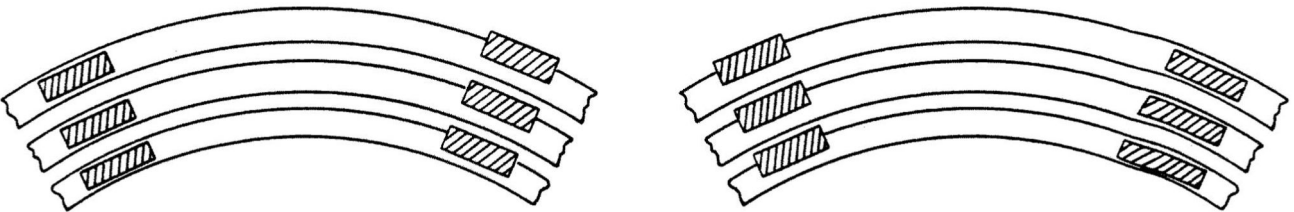

INCORRECT FACE ALIGNMENT

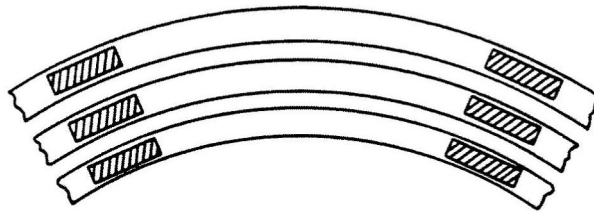

CORRECT FACE ALIGNMENT

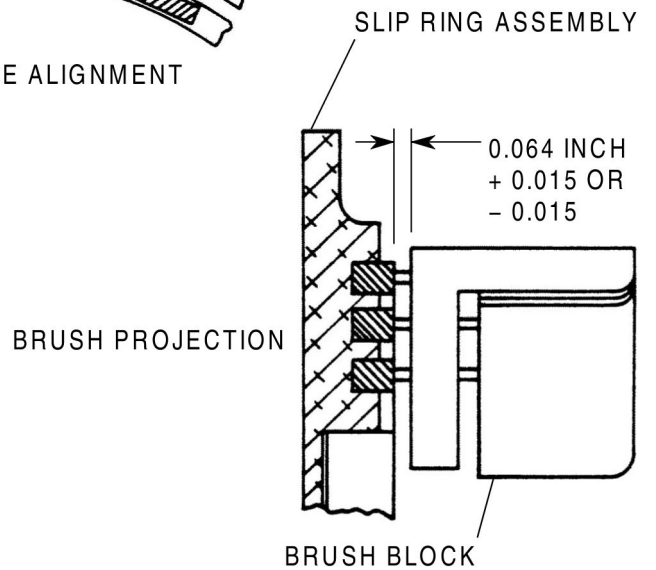

0103R1005

Brush/Slip Ring Alignment
Figure 403 (Sheet 1)

McCAULEY PROPELLER SYSTEMS
OWNER/OPERATOR
INFORMATION MANUAL

- (2) After the harness is connected to the deice boot leads, route the remainder of the harness to the slip ring assembly.

NOTE: Make sure the deice leads do not chafe the lockwire that secures the propeller blade balance weight holder. If required, install spaghetti tubing over the lockwire between the screws that secure the balance weight holder to the propeller blade.

- (a) Some wire harnesses will come with an alignment mark to help locate the wire harness, refer to figure 406.
 - (b) Most installations will secure and support the harness to the propeller bulkhead with a clamp located on the spinner bulkhead.
 - (c) Make sure all excess harness length is placed between the clamp/spinner bulkhead and the attachment to the deice boot leads. This will ensure proper harness length when the propeller blade is in its furthest angle away from the bulkhead clamp, whether it be reverse or feather position, depending upon the application.
 - (d) In addition to securing the deice harness to the clamp provided for attachment to the deice boot lead mounting bracket, some applications will require additional clamping on the blade shank or to the blade counterweight, refer to figure 406. For these installations, make sure all excess harness length occurs between the bulkhead clamp and the last clamp/attachment located on the blade shank.
 - (e) On all applications requiring additional clamping to the blade shank a special balance weight holder is supplied as part of the propeller assembly. This special holder has a provision for mounting the clamp refer to Figure 405.
- (3) After connecting the harness to the deice boot leads and clamp, bulkhead clamp and any additional blade shank clamps, route the remaining harness length to the slip ring assembly. Some applications require that the harnesses extend through the spinner bulkhead. On these applications, grommets are required in the bulkhead to prevent breakage of the harnesses. Some applications, using extended hubs, require that the wiring harnesses be routed along the propeller hub and are held in place with nylon tie wraps. Attach leads to corresponding slip ring studs with nuts and washers provided.

C. Installing Lead Straps (Integral Lead Type Boot)

- (1) The lead straps should be clamped to the spinner bulkhead with clamps provided. All excess strap length should fall between this clamp and the deice boot. A rubber grommet is to be used when routing the strap through the spinner bulkhead. Attach leads to the corresponding slip ring studs with nuts and washers provided. Torque nuts in accordance with the applicable installation drawing in the McCauley Propeller Systems Application Guide.

NOTE: Leads for both the wiring harnesses and lead straps are marked for attachment to the slip ring studs and to the deice boot leads when using the wire harness. However, the slip ring studs of the slip ring assembly are not marked. In all cases the smallest diameter slip ring is used as the ground, "G" connection. On a three ring slip ring assembly the largest diameter ring is used for the outboard or "O" connection and the middle ring is used for the inboard or "I" connection.

- (2) After installation of the wiring harnesses or lead straps is complete, make sure that the length is sufficient so as not to be placed in tension when the propeller is moved through full pitch range.

McCAULEY PROPELLER SYSTEMS
OWNER/OPERATOR
 INFORMATION MANUAL

C2353

ITEM	PART NO.	DESCRIPTION	RECOMMENDED TORQUE	QTY.
1	A-1635-40	SCREW	-	1
2	A-1635-63	SCREW	-	3
3	A-1638-18	WASHER	-	1
4	B-5024	INSULATOR	-	6
5	A-1638-17	WASHER	-	6
6	A-2873-5 OR -9	CLAMP	-	1
7	A-1639-38	NUT	12 TO 15 INCH POUNDS (1.4 TO 1.7 N-m)	1
8	A-1639-19	NUT	8 TO 10 INCH POUNDS (0.9 TO 1.1 N-m)	3

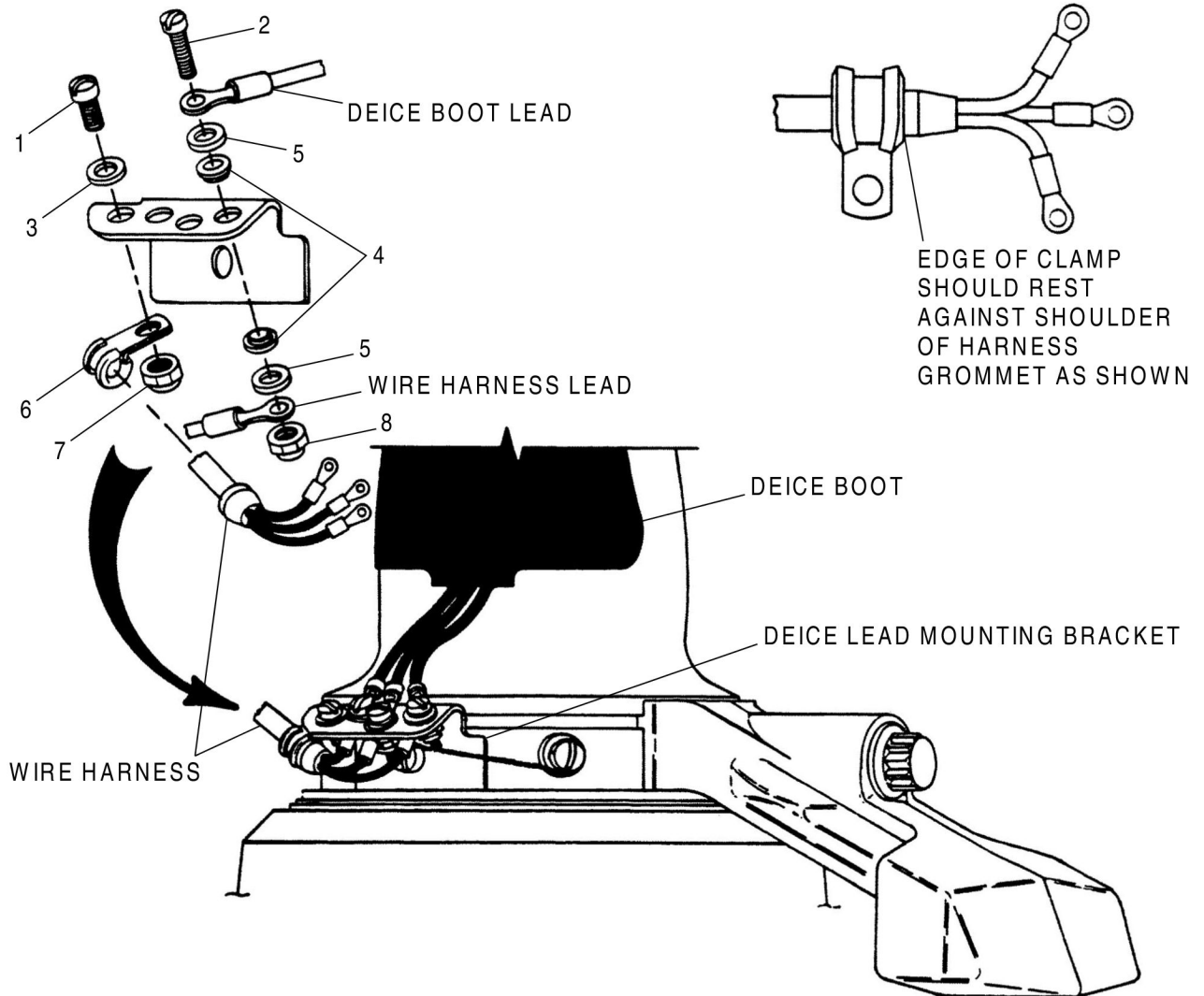

0103R1006

Deice Boot and Harness Lead Attachment (Detachable Leads)
 Figure 404 (Sheet 1)

McCAULEY PROPELLER SYSTEMS
OWNER/OPERATOR
INFORMATION MANUAL

C317

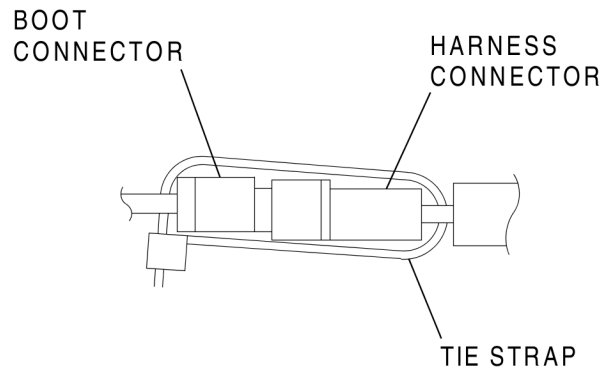
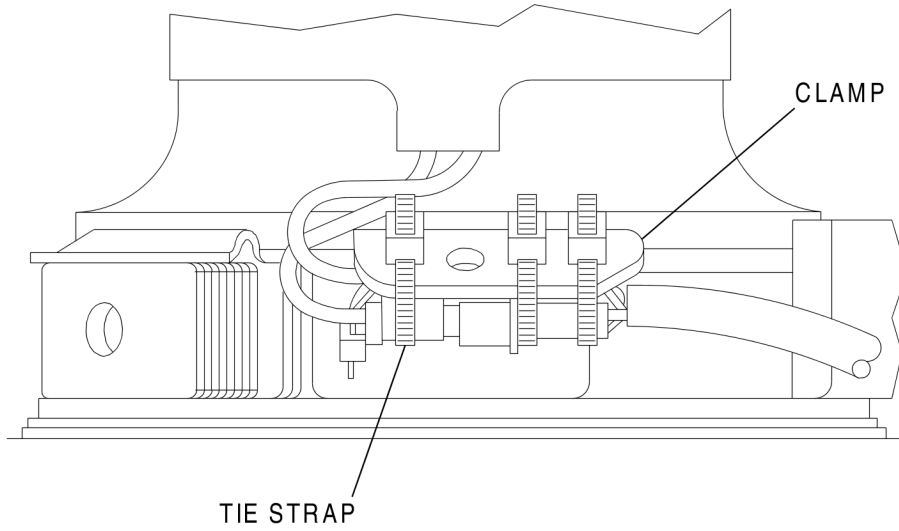

0101T1026

Harness Connection
Figure 405 (Sheet 1)

McCAULEY PROPELLER SYSTEMS
OWNER/OPERATOR
 INFORMATION MANUAL

C2391

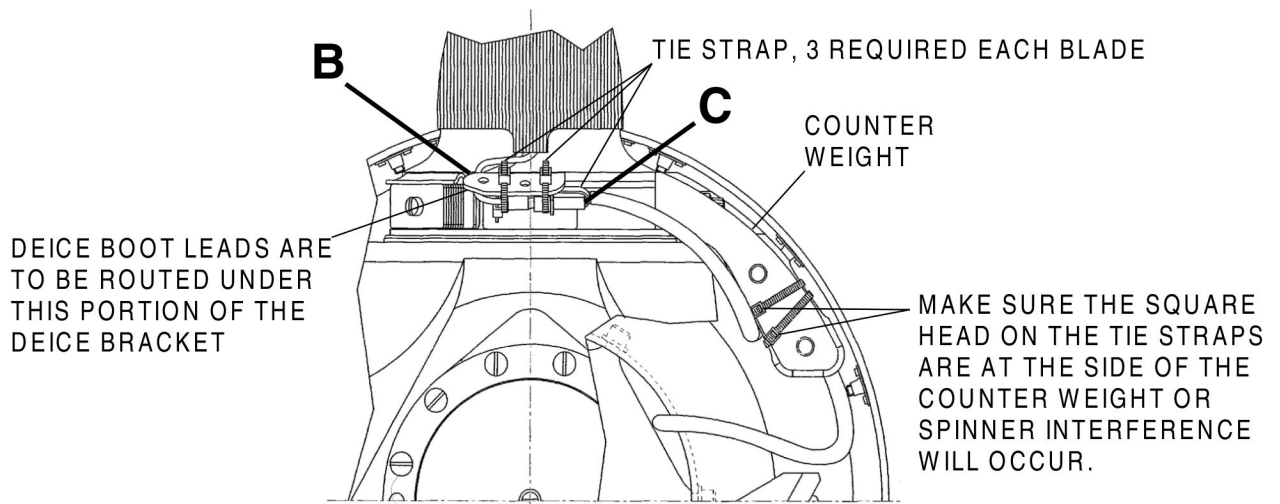
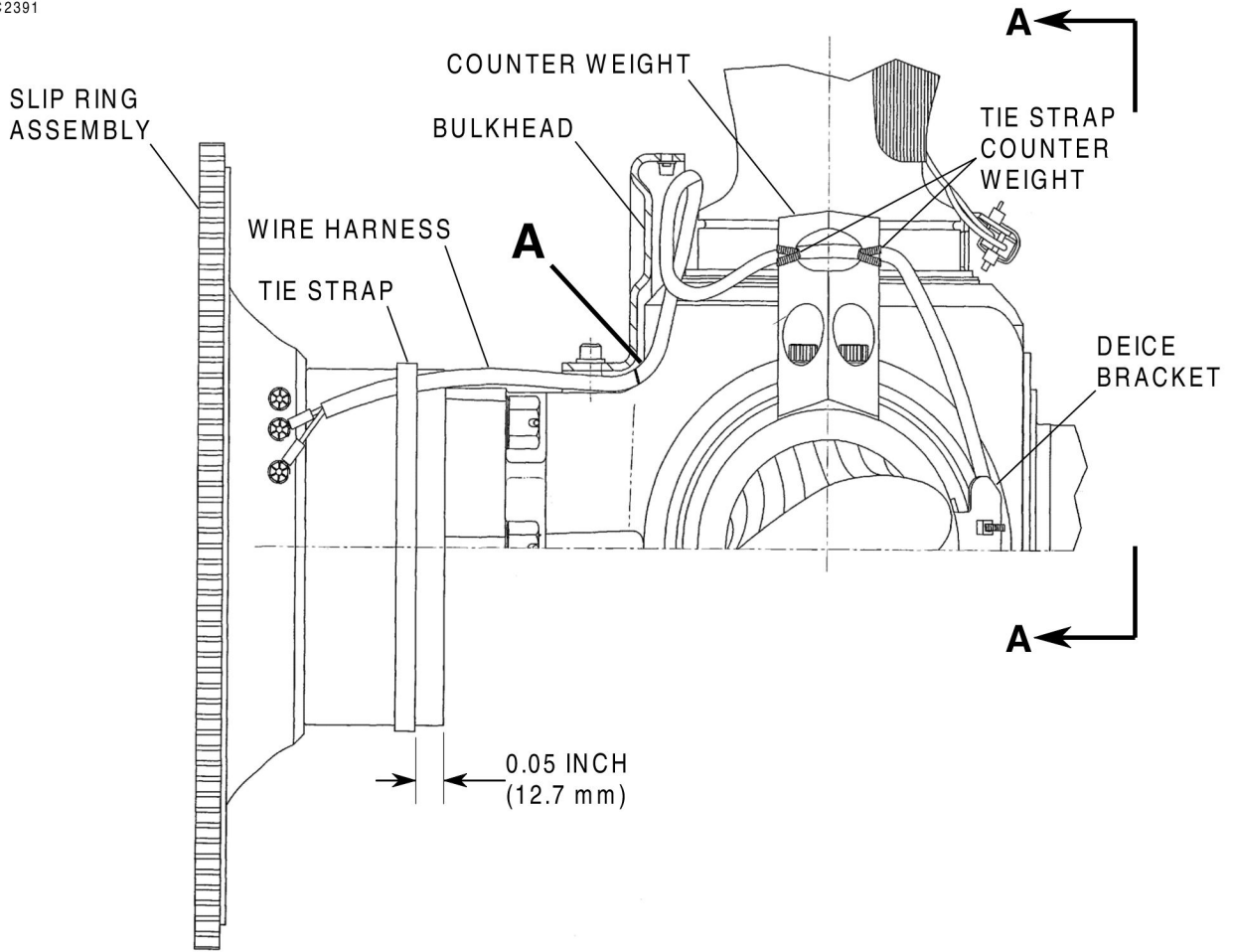

VIEW A-A

Deice Boot and Harness Lead Alternate Attachment (Detachable Leads)
 Figure 406 (Sheet 1)

McCAULEY PROPELLER SYSTEMS
OWNER/OPERATOR
 INFORMATION MANUAL

C2392

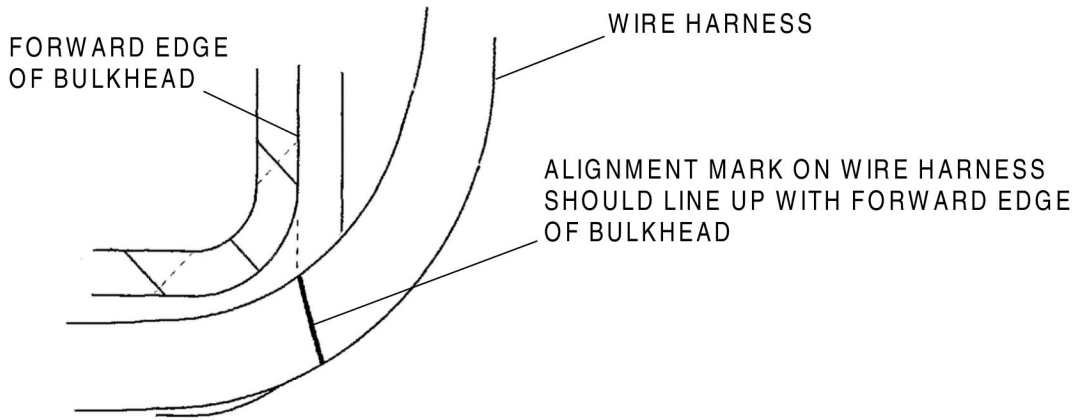

DETAIL A

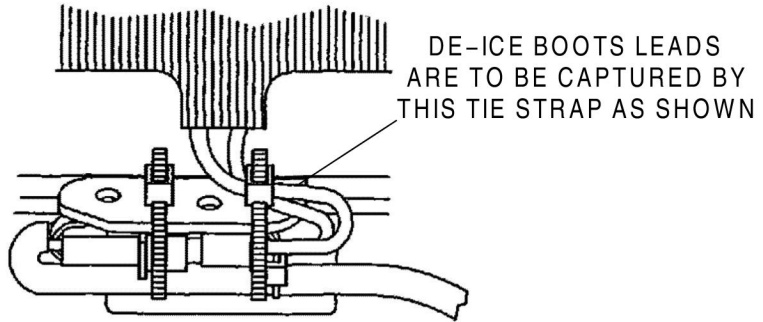

ALTERNATE WIRING ROUTE & TIE STRAP ATTACHMENT

DETAIL B

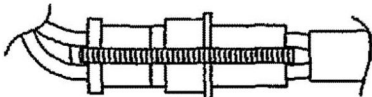

VIEW B-B

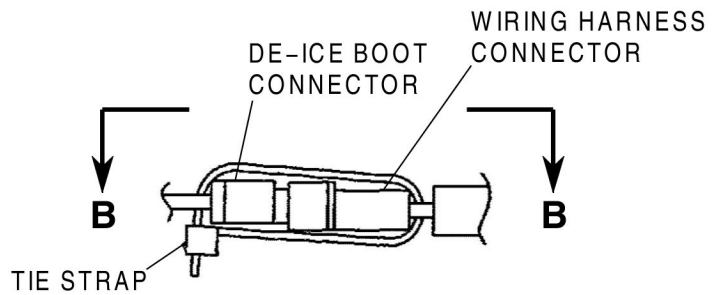

DE-ICE BOOT/WIRING HARNESS PLUG CONNECTION

DETAIL C

Deice Boot and Harness Lead Alternate Attachment (Detachable Leads)
 Figure 406 (Sheet 2)

McCAULEY PROPELLER SYSTEMS
OWNER/OPERATOR
INFORMATION MANUAL

CAUTION: Do not run engines with spinner dome removed; damage will result to the wiring harnesses or lead straps due to the centrifugal force of a spinning propeller.

6. Timer Installation

CAUTION: Before installing the timer, check the part number on the timer label and compare to the number called out by the airplane TC or propeller STC information. There are several different McCauley timers with similar external appearance but are not interchangeable due to the different cycle times of each timer.

- A. Follow the aircraft manufacturers or propeller STC recommendations for the location and installation of the timer.

7. Ammeter, Switch, and Circuit Breaker Installation

- A. Installation and service procedures for these items should be obtained from the aircraft manufacturer or STC instructions as applicable.

McCAULEY PROPELLER SYSTEMS
OWNER/OPERATOR
INFORMATION MANUAL

DEICE SYSTEM - ADJUSTMENT/TEST

1. Introduction

- A. The following checks are intended to determine if a component of the deice system is performing in a manner that will provide reliable operation of the propeller deice system.

2. Slip Ring Run-Out Test

- A. Severe arcing and brush wear often occur when there is a "wobble" in the starter ring gear/slip ring assembly, pulley/slip ring assembly, or slip ring assembly. This condition, if allowed to exist, will cause the brushes to constantly ride in and out of the brush holder resulting in rapid deterioration of the brush/slip ring surfaces and will lead to eventual failure of the deice system.
- B. To alleviate this condition, make sure that the slip ring face run-out does not exceed 0.008 inch (0.20 mm) total indicator reading (TIR). Check the run-out in the following manner:
- (1) Mount a dial indicator to the engine case.
 - (2) Rotate the slip ring through 360 degrees of rotation.
 - (3) Observe the dial indicator for a total indicator reading not to exceed 0.008 inch (0.20 mm).

CAUTION: Removal and installation of slip ring assemblies on McCauley propellers for Pratt & Whitney engine installations are limited to **AUTHORIZED FAA APPROVED PROPELLER REPAIR STATIONS ONLY**. Partial disassembly of the propeller is required.

- (4) If the reading exceeds 0.008 inch (0.20 mm), the slip ring assembly must be removed and re-machined. Only authorized FAA approved propeller repair stations shall machine McCauley deice slip ring assemblies

CAUTION: Do not, under any circumstances, attempt to correct the run-out of the slip rings by shimming the assembly or changing the torque of the mounting screws or bolts.

- (5) If the reading is exceeded on the assemblies which mount between the propeller engine flange and the propeller hub, remove the assembly, clean the mounting surfaces, reinstall, and recheck the run-out.
- (6) After the run-out is corrected, check the brush block assembly to slip ring alignment in accordance with Section 61-10-40, Deice System Installation, Brush Block Assembly and Mounting Bracket Installation, Brush Block Assembly Alignment Requirements.

3. Brush Block Continuity Test

- A. Remove the brush block assembly from the mounting bracket and check for continuity between each brush and pigtail lead. If defective, see Section 61-10-40, Deice System Repair, Brush Block and Mounting Bracket Assemblies for repair of the brush block assembly.

McCAULEY PROPELLER SYSTEMS
OWNER/OPERATOR
INFORMATION MANUAL

DEICE SYSTEM - INSPECTION/CHECK

1. General

- A. To preserve the aircraft battery when making ground checkouts, run a minimum number of cycles with the propeller in the static condition. Use of an auxiliary power supply is suggested.

CAUTION: The deice boots should not be operated continuously for more than five minutes under high ambient temperature conditions (above 100 °F or 37.8° C) without allowing them to cool down to ambient temperature.

2. 100 Hour Inspection

- A. Remove spinner dome and open access doors as necessary. Do not run an engine with the spinner dome removed or failure of the lead straps, wiring harnesses, and damage to the spinner fillets will occur.
- B. Deice Boots.
- (1) Closely check each deice boot for wrinkled, loose, or torn areas, particularly around the outboard edges and where the lead strap passes under the rubber restrainer strap. Look for abrasion or cuts, especially along the leading edge and the face or flat side of the blade.
 - (a) Foreign object damage must be given careful inspection, not just for damage to the boot or heating element, but also for blade damage beneath the boot. Deice boot elasticity may obscure blade damage. If the boot is damaged or cut completely through to the blade or if blade damage beneath a boot is suspected, the boot must be removed for blade inspection/repair.
 - (b) A damaged deice boot may result in an electrical open or short circuit in the boot heating element. Deice boot replacement is required for any boot with an electrical short or open. A damaged heating element may also cause arcing to the propeller blade surface. Damage of this type (electrical short to the propeller blade) may also require the blade to be replaced.
 - (2) Check that the lead strap clamps, terminal clamps, and tie wraps are secured and properly installed. Look for cracks or other damage in the deice boots. Make sure that screws with provisions for lockwire are properly safetywired.
 - (3) Check that deice boot lead straps or wire harnesses are not placed in tension throughout the blade travel. If tension in the lead straps exists, make sure that all excess harness length falls between the last clamp found on the blade shank and the clamp found on the spinner bulkhead.
 - (a) If tension still exists, check deice boot location dimension ("Y") given in Table 401 and deice boot part number. If location exceeds given dimension, and part number is correct, remove and replace the deice boot and reapply boot in accordance with Section 61-10-40, Deice System - Removal/Installation, Deice Boot Installation. If part number is incorrect, replace with correct part number deice boot. All deice boots must be located the same distance from the hub for rotational balance.
 - (b) On detachable lead type boots, check that terminals are not shorting out to each other. Inspect all wiring harnesses for evidence of chafing or shorting. If chafing is found, remove source and replace harness. Make sure that all clamps and tie straps are properly installed.
 - (4) Make sure that lead strap clamps and terminal screw assemblies are tight and in good condition.
 - (5) With the deice system switch ON and an assistant observing the ammeter, flex the lead straps or wire harnesses of the deice boots which are operating. Any movement of the ammeter needle, other than the normal flicker from the timer cycling, indicates a short or open circuit that must be located and corrected. Check the continuity of wiring affected while flexing and prodding the suspected area.
 - (6) With the deice switch ON, feel the deice boots on propeller(s) for the proper sequence of heater operation. For the proper sequence of operation, refer to Section 61-10-40, Deice System Description, Types of Deice Systems and related figures. Temperature rise should be noticeable and each heater should warm while energized. Local hot spots indicate surface damage requiring replacement of the deice boot.

McCAULEY PROPELLER SYSTEMS
OWNER/OPERATOR
INFORMATION MANUAL

- C. Slip Ring Assembly
- (1) Visually and by feel check the slip rings for excessive wear, rough surfaces, cracks, burned or discolored areas, and deposits of oil, grease, and dirt.
 - (2) Clean greasy or contaminated slip rings with Methyl n-Propyl Ketone (MPK), or equivalent cleaner.
 - (3) If uneven wear is found or if wobble is noticed, set up a dial indicator and check the run-out of the slip ring assembly (refer to, Deice System - Adjustment/Test, Slip Ring Run-Out Test).
 - (4) Replace or repair worn or damaged slip rings in accordance with Section 61-10-40, Deice System Repair, Slip Ring Assembly.
- D. Brush Block Assembly and Mounting Bracket
- (1) Examine mounting brackets and brush block assemblies for cracks, deformation, or other physical damage. Remove dirt and oil and check to make sure that the torque has not been lost on mounting bolts and other screws of this assembly. Check for damage of insulator fins of terminal strip on mounting bracket.
 - (2) Check brushes for excessive wear, chipping, or breakage. To check brushes for wear while mounted on aircraft, insert a small diameter feeler gage in the slots provided on the sides of the brush block assembly. If the gage can pass beyond the bottom of the brush, the assembly must be overhauled or replaced. The brush block assembly should be dismantled and the brush length measured periodically in order to determine usable remaining brush lengths (refer to Section 61-10-40, Deice System Repair, Brush Block and Mounting Bracket Assemblies).

CAUTION: Do not soak brush block assembly in MPK.

- (3) Check brush block assembly for accumulation of grease or fuel and for accumulation of carbon deposits on the block between the brushes. Clean the assembly using MPK and dry with compressed air and check the brushes for wear. Repair the source of contaminant leakage. To repair the brush block assembly, (refer to Section 61-10-40, Deice System Repair, Brush Block and Mounting Bracket Assemblies for repair procedures).
 - (4) Make sure that each brush rides fully on its slip ring throughout the 360 degree rotation (refer to Section 61-10-40, Deice System Installation, Brush Block Assembly and Mounting Bracket Installation, Brush Block Assembly Alignment Requirements and Figure 402). for brush alignment information.
 - (5) Check for proper clearance between the brush block and the slip ring assembly (refer to Section 61-10-40, Deice System Installation, Brush Block Assembly and Mounting Bracket Installation, Brush Block Assembly Alignment Requirements). Loosen the mounting screws and move the assembly as necessary to properly align the brush block assembly.
- E. Timer Test

NOTE: This test is necessary as a 100 hour inspection item only if the deice boot heat test or the ammeter reading is outside the normal current range and indicates a system malfunction.

- (1) The correctness of the timer cycling sequence should be checked as follows (refer to Table 601 for appropriate pins and sequence):

NOTE: For a bench checkout of the timer, use a power supply capable of 0-30 VDC with a range of 0-20 amps; 2% or less ripple, and a voltmeter to check the output pin timing. Use a minimum 10 amp load for each output.

NOTE: Ripple is the small unwanted residual periodic variation of the direct current (DC) output of a power supply which has been derived from an alternating current (AC) source. This ripple is due to incomplete suppression of the alternating waveform within the power supply.

- (a) Remove the connector plug of the wire harness from the timer and connect a jumper from the power input socket to the timer input pin. Refer to Table 601 for pin identification information.
- (b) Connect a jumper from the timer ground pin to ground.

McCAULEY PROPELLER SYSTEMS
OWNER/OPERATOR
 INFORMATION MANUAL

- (c) Turn on the deice system.
- (d) Check the timer operation in accordance with Table 601 using a voltmeter.
- (e) Check the voltage to ground in each case. If the engines are not operating and no auxiliary power is used, the voltage may be too low for the timer to operate properly. The voltage should not drop below 22 VDC while checking the timer.
- (f) Hold the voltmeter probe on the energized pin until the voltage drops to 0 VDC. Move the probe to the next pin in the sequence as shown in the table. Check the voltages of each pin in sequence. When the correctness of the cycling sequence is established, turn the propeller deice switch off.
- (g) If the timer operates correctly, remove the jumpers installed and replace the connector plug in the timer receptacle. If the timer does not operate correctly, remove and replace the timer. If the timer cycles, but not in the proper sequence, make sure the correct part number timer is installed. Follow the aircraft manufacturer's recommendations for the installation of the timer.

NOTE: Refer to 61-10-40, Illustrated Parts List, Deice timers, for a listing of solid state timers that are a direct replacement for some of the existing mechanical timers.

Table 601. Timer Operation Test

Timer Part No.	Power Input Pin and Socket	Ground Pin	Output Sequence Time, Voltage	Total Repeat Cycle Time
B-45018	B	G	D, F - 90 sec. each, then repeats (28 VDC)	3 min.
C-45114	B	G	D, F - 90 sec. each, then repeats (28 VDC)	3 min.
B-45020	B	G	C, D - 34 sec. each, then repeats (28 VDC)	1 min. 8 sec.
B-45043	B	G	C&D, E&F - 90 sec. each, then repeats (28 VDC)	3 min.
C-45116	B	G	C&D, E&F - 90 sec. each, then repeats (28 VDC)	3 min.
B-45052	B	F	C 90 sec., then repeat (28 VDC)	3 min.
B-45103	B	G	C&E, D&F - 90 sec. each, then repeats (28 VDC)	3 min.
C-45118	B	G	C&E, D&F - 90 sec. each, then repeats (28 VDC)	3 min.

McCAULEY PROPELLER SYSTEMS
OWNER/OPERATOR
 INFORMATION MANUAL

Table 601. Timer Operation Test (continued)

Timer Part No.	Power Input Pin and Socket	Ground Pin	Output Sequence Time, Voltage	Total Repeat Cycle Time
C-45133	A (Deice Boots) B (Circuit Board)	F	C, 90 sec. then repeat (28 VDC)	3 min
D-45059	"POWER IN"	"GROUND"	"SWITCHED OUTPUT No1" "SWITCHED OUTPUT No2" 35 sec. each ("SLOW" timer output speed is selected)	70 sec.
			"SWITCHED OUTPUT No1" "SWITCHED OUTPUT No2" 70 sec. each ("FAST" timer output speed is selected)	140 sec.

- F. Ammeter, Circuit Breaker, and Switch
 - (1) Procedures for testing these items should be referred to the aircraft manufacturer's service or maintenance manual.
- G. System Wiring
 - (1) With the deice system operating, have an assistant observe the ammeter while visually inspecting and physically flexing the wiring from the brush block to the fire wall, timer, ammeter, switch, circuit breaker, and aircraft power supply. Any movement of the ammeter needle other than a flicker from the timer cycling indicates a loose or broken wire in the area under examination. In such case, check the continuity through the affected wiring while flexing and prodding the area that gave the initial indication of a malfunction. Follow the aircraft manufacturer's procedures for inspection and correction.
- H. Other
 - (1) Visually and by feel check all clamps, mountings, electrical connections, and connectors for corrosion, tightness, and electrical soundness. Check for loose, broken, or missing safety wire.
 - (2) Replace all previously removed components.
 - (3) Check for radio noise or radio compass interference. Operate the engine at near take-off power with the radio and navigation equipment powered on while turning the deice system switch on and off. If noise or interference is detected, refer to the troubleshooting chart in Section 61-10-40, Deice System Service, Trouble Shooting Guide.

3. Deice Boot Resistance Test

- A. To determine the deice boot resistance, disconnect the leads from the mounting bracket (detachable lead type boot) or slip ring assembly (integral lead type boot). Check the resistance between the ground lead ("G") and inboard lead ("I"), then between the ground ("G") lead and the outboard lead ("O") of a dual element boot. Check the resistance on a single element boot between the ground lead ("G") and the positive lead ("I"). Compare the readings with the maximum and minimum values listed in Section 61-10-40, Deice System Installation, Table 602 Deice Boot Resistance Values for that particular deice boot part number. If not within limits, replace the boot in accordance with Section 61-10-40, Deice System Repair, Deice Boot Replacement.
 - (1) Deice Boot Resistance Values
 - (a) For initial installation or if the deice boot heating element is suspected to be damaged or not operating correctly, check the deice boot resistance (refer to Table 602, for deice boot resistance values).

McCAULEY PROPELLER SYSTEMS
OWNER/OPERATOR
 INFORMATION MANUAL

Table 602. Deice Boot Resistance Values

McCaughey Deice Boot Part No.	RESISTANCE VALUES (ohms) (Note 1)		NOTES
	Maximum Resistance (Ohms)	Minimum Resistance (Ohms)	
B-40183-03	5.26	4.58	Dual element boot
B-40183-04	5.21	4.53	Dual element boot
B-40183-07	1.90	1.72	Single element boot
B-40183-16	2.32	2.03	Dual element boot
B-40183-17	2.32	2.03	Dual element boot
B-40183-18	5.26	4.58	Dual element boot
B-40183-19	5.26	4.58	Dual element boot
B-40183-20	5.26	4.58	Dual element boot
B-40183-55	1.118	1.007	Single element boot
B-40245-50	5.04	4.56	Single element boot
B-40245-52	5.04	4.56	Single element boot
B-40245-53	5.04	4.56	Single Element boot with integral lead
B-40245-54	3.60	3.26	Single element boot with connector plug
B-40245-56	5.04	4.56	Single element boot with connector plug
B-40245-57	4.90	4.70	Single Element boot with integral lead
B-40245-58	2.23	2.10	Dual Element boot with integral lead
B-40245-60	5.04	4.56	Single Element boot with integral lead
B-40245-61	1.26	1.14	Single Element boot with integral lead

NOTE 1: If the propeller is installed on the airplane, the propeller deice boot leads must be electrically isolated from the rest of the aircraft wiring (including the deice brush blocks) when making the above resistance check. Measure electrical resistance between the ground lead and the positive lead or leads (if dual element deice boots are installed) of each deice boot.

4. Slip Ring

- A. To determine if the slip ring has sufficient conductor material in each of the conductor rings for continued operation, do the following:
 - (1) Measure the thickness of the slip ring assembly at the thinnest point of each of the conductor rings. You will have to take multiple measurements to confirm you have the thinnest point on each conductor ring of the slip ring assembly. Measure from the conductor surface (engine side of ring) to the opposite side of ring (propeller side), refer to Table 603 for slip ring minimum serviceable thickness dimension.

McCAULEY PROPELLER SYSTEMS
OWNER/OPERATOR
 INFORMATION MANUAL

Table 603. Deice Slip Ring Conductor Minimum Thickness.

Slip Ring Assembly Part Number	Minimum Dimension
D-40000	0.435 Inch (11.05 mm)
D-40034	0.435 Inch (11.05 mm)
D-40099	0.435 Inch (11.05 mm)
D-40106	0.435 Inch (11.05 mm)
D-40112	0.435 Inch (11.05 mm)
D-40161	0.369 Inch (9.37 mm)
D-40174	0.435 Inch (11.05 mm)
D-40238	0.435 Inch (11.05 mm)
D-40260	0.435 Inch (11.05 mm)
D-40283	0.435 Inch (11.05 mm)
D-40354	0.435 Inch (11.05 mm)
D-40364	0.435 Inch (11.05 mm)
D-40420	0.435 Inch (11.05 mm)
D-40498	0.369 Inch (9.37 mm)
D-40505	0.549 Inch (13.94 mm)
D-40553	0.435 Inch (11.05 mm)
D-40592	0.435 Inch (11.05 mm)
D-40653	0.435 Inch (11.05 mm)
D-40663	0.435 Inch (11.05 mm)
D-40667	0.435 Inch (11.05 mm)

McCAULEY PROPELLER SYSTEMS
OWNER/OPERATOR
INFORMATION MANUAL

DEICE SYSTEM - REPAIR

1. Introduction

A. Use of Correct Parts

- (1) The type and number of deice boots determine the system current drain. The timer, wiring harnesses, and brush block assemblies are designed to operate at that current. Accordingly, only the deice boots, timer, wiring harnesses, and brush block assemblies specified for use on a particular aircraft may be used without affecting the deice system operation. When replacing worn or inoperative parts, make sure that the replacement instructions are followed explicitly.

B. Electrical

- (1) To attach terminals to the wire, use a crimping tool which crimps both sides of the terminal to avoid loosening of the insulation. Make sure that the terminal is crimped on both the insulation and bare wire. If the wires are too short to repair, replace the component with the correct part number.
- (2) Bent pins on the timer receptacle may be straightened with long nose pliers. However, make sure that work hardening does not leave the pin brittle and susceptible to breakage. If the timer is suspected of being damaged, replace the timer.
- (3) Chafed or worn areas of the wire harness should be repaired, repositioned and protected from chafing with vinyl tubing. If the insulation has worn thru the insulation and has exposed bare wire, replace the chafed area of the wire harness or replace the harness.

C. Mechanical

- (1) Use safety wire at the timer, brush block assembly, slip ring assembly, and wherever provisions are made for its use. Tighten all mounting hardware and electrical connections firmly or according to the torque values given. Avoid excess force which might strip the threads.

2. Ammeter, Switch, and Circuit Breaker

- A. Follow the aircraft manufacturer's recommendations for repair and replacement of these items.

3. Timer

- A. McCauley deice timers are not designed for field repair. If failure should occur, replace the timer with the correct part number and use the same or equivalent hardware for mounting and making electrical connections as was used originally. Follow the aircraft manufacturer's recommendations for removal and installation instructions.

4. Slip Ring Assembly

CAUTION: Removal and installation of slip ring assemblies on McCauley propellers for Pratt & Whitney engine installations are limited to **AUTHORIZED FAA APPROVED PROPELLER REPAIR STATIONS ONLY**. Partial disassembly of the propeller is required.

- A. When a chattering or screeching noise is emitted from the brush/slip ring area, the probable cause is the incorrect alignment of the brush block and slip ring assemblies.

NOTE: Chattering or screeching may be detected by pulling each propeller through slowly in the direction of engine rotation and should be corrected immediately. If this chattering or screeching noise is noticed over the idling engine noises, the trouble is severe and should also be corrected immediately.

NOTE: Surface friction from the brushes will produce a concave wear pattern on the slip rings. This does not necessitate replacement or re-machine/refinish the contact surface unless rapid brush wear is encountered due to extreme wear or surface roughness of the slip rings. When a new brush block assembly is installed on the slip rings which have only minor wear patterns, a rapid seating to the slip ring occurs without degradation of operation or service life.

McCAULEY PROPELLER SYSTEMS
OWNER/OPERATOR
INFORMATION MANUAL

- B. Machining
 - (1) Machining of a slip ring assembly should only be accomplished at an authorized FAA approved propeller repair station.
- C. Replacement
 - (1) Slip ring assemblies that are open electrically, cracked, or damaged structurally, or which have damaged surfaces beyond the scope of minor repair, should be replaced with new assemblies. Install in accordance with Section 61-10-40, Deice System - Removal/Installation, Slip Ring Installation. Align the slip ring assembly with the brush block assembly in accordance with Section 61-10-40, Deice System - Removal/Installation, Brush Block Assembly and Mounting Bracket Installation, Brush Block Assembly Alignment Requirements.
- D. Slip Ring Studs
 - (1) McCauley slip ring assemblies use a stud brazed to the slip ring for making the electrical connection. While performing any work around these studs, avoid any side loads on the studs which might cause breakage of the brazed joint and failure of the slip ring. Broken or missing studs cannot be repaired in the field - the assembly must be replaced.
- E. Eccentric Running
 - (1) If the brush block assembly cannot be adjusted sufficiently to prevent brushes from riding partially off the edge of the slip rings through 360 degrees of rotation, the slip ring assembly mounting holes or the slip rings are not concentric. There is no adjustment for this condition. Therefore, the slip ring assembly must be replaced.

5. Brush Block and Mounting Bracket Assemblies

- A. Brush Block Assembly Repair
 - (1) (Except for C-40543 brush block assemblies.) The brushes must be replaced when only 0.094 inch of brush material extends beyond the brush holder. To correctly measure this dimension, insert a small diameter feeler gage into the slots provided on the side of the brush holder. With the feeler gage inserted into the slot, push down on the brush until it bottoms out on the gage. Measure the distance between the top surface of the holder and the face of the brush. If this dimension is 0.094 inch or less, the brush and holder assembly should be replaced. Continue this procedure for each brush (see Figure 801).
 - (2) (For C-40543 brush block assemblies only.) The brushes must be replaced when the length of the brushes is less than 0.375 inch (see Figure 802). To measure the brushes the B-40416 and B-40563 brush and holder assemblies must be removed from the C-40652 brush block.
- B. Replacement of Brushes
 - (1) When replacing brushes, record the type and part number of the brush block assembly to make sure the correct replacement of the brush and holder assemblies are being ordered.
 - (2) To replace the brushes, disassemble the brush block assembly by removing the two screws found on the back of the assembly. After removing the screws, pull the metal brackets off the brush holder, which will in turn remove the brushes from the slots in the holder. Discard the brush and holder assemblies and replace them with the correct part number. Replace the brush and holder assembly by first inserting the brushes into the slots and then sliding the new bracket into place. Install the two screws back into place and test the brushes by pushing them into the holder to make sure that they spring back. If the brushes bind up and do not spring back, loosen the screws and reposition the bracket so that the brushes ride freely in the slots (see Figure 801).
 - (3) After the replacement of brushes is complete, install the brush block assembly in accordance with 61-10-40, Deice System Installation, Brush Block Assembly and Mounting Bracket Installation. Align the brushes to the slip rings in accordance with Section 61-10-40, Deice System Installation, Brush Block Assembly and Mounting Bracket Installation, Brush Block Assembly Alignment Requirements.
- C. Mounting Bracket Repair
 - (1) If damage has occurred to the metal bracket it must be replaced. If damage has occurred to the terminal strip on the mounting bracket, the damaged terminal strip shall be replaced.

McCAULEY PROPELLER SYSTEMS
OWNER/OPERATOR
INFORMATION MANUAL

C1864

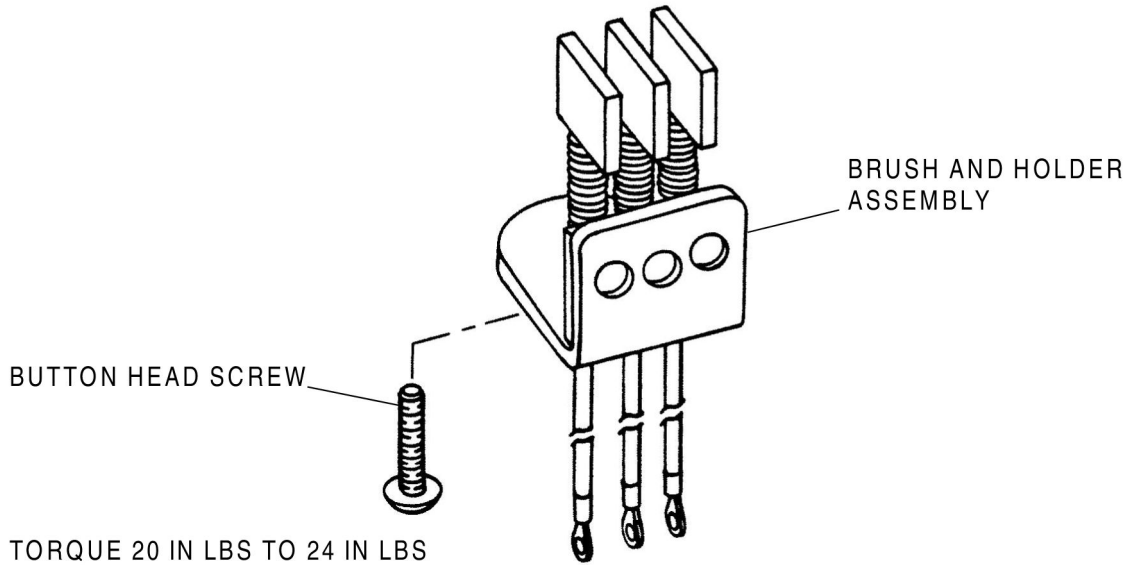
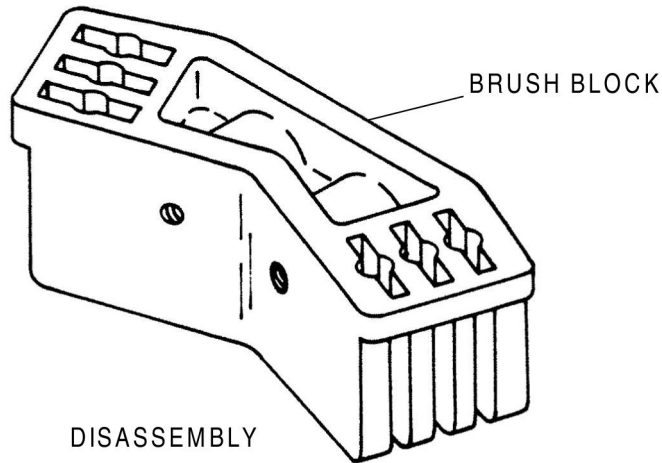
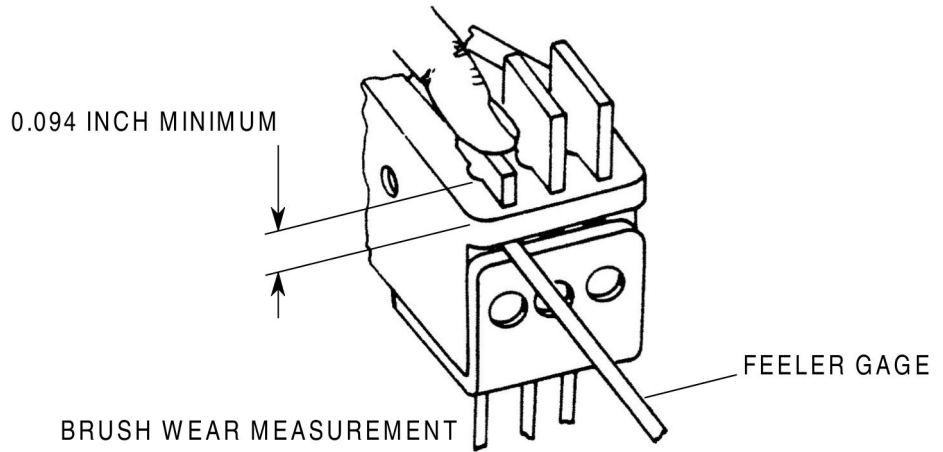

0103R1009

Brush Block Assembly Repair
Figure 801 (Sheet 1)

McCAULEY PROPELLER SYSTEMS
OWNER/OPERATOR
INFORMATION MANUAL

C1865

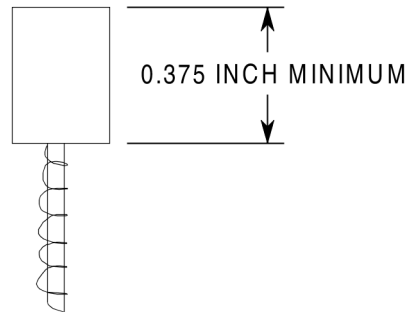

0103T1010

Measuring Deice Brushes in C-40543 Brush Block Assemblies
Figure 802 (Sheet 1)

6. Deice Boot Replacement

A. Deice Boot Replacement

- (1) Refer to Deice System - Removal/Installation, Deice Boot Removal and Installation for deice boot removal and installation procedures.

McCAULEY PROPELLER SYSTEMS
OWNER/OPERATOR
 INFORMATION MANUAL

ILLUSTRATED PARTS LIST

1. Illustrated Deice Parts List C400 Series Propellers

A. An exploded view of a typical C400 Series propeller McCauley supplied deice equipment appears following the Master Deice Parts List (Tables 1001 and 1002). The index numbers for parts in the illustration are used to identify detail part numbers, assemblies, or groups of similar part numbers in the Parts List.

- (1) Figure 1001 illustrates McCauley installed deice systems
- (2) Refer to the McCauley Propeller Systems Application Guide (MAG) and the aircraft type certificate data sheet for applications of specific part numbers.

NOTE: The MAG is **not** an FAA approved document, and is for reference only. Refer to the appropriate Type Certificate Data Sheet (TCDS) or Supplemental Type Certificate (STC) to verify information contained in the MAG.

Table 1001. C400 Series Propeller Blade Deice Boots

PART NUMBER	DESCRIPTION	QTY	C	C	C	C				
			4	4	4	4	C	C	C	C
			0	0	0	0				
			6	6	9	9	C	C	C	C
			-	-	-	-	4	4	4	4
			0	5	0	5	3	3	4	4
			X	X	X	X	0	2	2	4
B-40245-53	Boot	3	X	X	X	X		X	X	
B-40245-60	Boot 28-volt system	3					X			X
B-40245-61	Boot 14-volt system	3					X			X

Table 1002. C400 Series McCauley provided Deice Equipment Installations

INDEX NO.	PART NUMBER	DESCRIPTION	QTY	D-40242 Beech STC 406, 409	E-40656 Cessna 182, 206 Restart	D-40726 Bonanza A36TC	D-60198 Mooney STC
151	D-40238	Slip ring assembly	1	X			
151	D-40498	Slip ring assembly	1		X		
151	D-40720	Slip ring assembly	1			X	
152	A-40008	Washer	8	X		X	
153	A-1639-18	Nut	6		X		
153	A-1639-18	Nut	8	X		X	
154	A-1638-17	Washer	16	X		X	
155	A-1639-19	Nut	8	X		X	
156	A-40138	Bushing	6		X		
157	C-40257	Brush block assembly	1	X		X	
157	C-40660	Brush block assembly	1		X		

McCAULEY PROPELLER SYSTEMS
OWNER/OPERATOR
 INFORMATION MANUAL

Table 1002. C400 Series McCauley provided Deice Equipment Installations (continued)

INDEX NO.	PART NUMBER	DESCRIPTION	QTY	D-40242 Beech STC 406, 409	E-40656 Cessna 182, 206 Restart	D-40726 Bonanza A36TC	D-60198 Mooney STC
158	C-40151	..Brush block	1	X	X	X	
159	C-40256-1	..Brush and holder assembly (left)	1	X		X	
159	C-40256-2	..Brush and holder assembly (right)	1	X		X	
159	C-40522-1	..Brush and holder assembly (left)	1		X		
159	C-40522-2	..Brush and holder assembly (right)	1		X		
160	A-1635-127	..Screw	2	X	X	X	
161	C-40298	Bracket assembly	1	X		X	
161	C-40494	Bracket assembly	1		X		
162	C-40026	..Bracket	1	X		X	
162	C-40493	..Bracket	1		X		
163	A-1635-139	..Screw	2	X		X	
164	A-1639-19	..Nut	2	X	X	X	
165	A-1635-146	..Screw	2		X		
166	A-1639-18	..Nut	2		X		
166	A-1639-43	..Nut	2		X		
167	A-2873-4	..Clamp	1	X		X	
168	A-1635-15	..Screw	1	X		X	
169	A-1638-17	..Washer	2		X		
169	A-1638-7	..Washer	1	X		X	
170	A-40253	..Terminal strip	1	X		X	
170	A-40476	..Terminal strip	1		X		
171	A-40357	..Terminal block	1	X		X	
172	A-1635-148	..Screw	2	X		X	
173	A-20582-3	..Washer, lock	2	X		X	
174	A-1638-21	Washer (shim)	AR	X	X	X	
175	B-40024-2	Spacer	2	X		X	
176	B-40024-7	Spacer	2		X		
176	B-40030-3	Spacer	4	X		X	
177	A-2513-36	Bolt	2	X		X	
177	A-2513-85	Bolt	1		X		
178	A-1638-7	Washer	2	X	X	X	

McCAULEY PROPELLER SYSTEMS
OWNER/OPERATOR
 INFORMATION MANUAL

Table 1002. C400 Series McCauley provided Deice Equipment Installations (continued)

INDEX NO.	PART NUMBER	DESCRIPTION	QTY	D-40242 Beech STC 406, 409	E-40656 Cessna 182, 206 Restart	D-40726 Bonanza A36TC	D-60198 Mooney STC
179	A-1635-100	Screw	2		X		
179	A-1635-77	Screw	2	X		X	
180	A-1638-22	Washer	4	X		X	
181	A-1638-23	Washer	AR	X		X	
182	A-1635-22	Nut	2	X		X	
183	A-1635-56	Screw	6	X		X	
184	A-1638-18	Washer	12	X		X	
185	B-40251	Restraining strap	3	X	X	X	
186	A-2873-14	Clamp	3	X	X	X	X
187	A-40671	Grommet	3				X
187	MS35489-150	Grommet	3		X		
187	MS35489-42	Grommet	3	X		X	
188	A-20360-4	Tie strap	1		X		X
189	B-40187	Wire lead, dual element	3				X
189	B-40677	Wire lead, single element	3				X
189	B-40705	Wire lead	3		X		
190	A-1639-38	Nut	6		X	X	X
191	A-1238-26	Washer	12		X		X
192	A-1635-40	Screw	6		X		X
193	A-1638-19	Washer	12		X		X
194	A-1639-19	Nut	6		X		X
195	A-1635-139	Screw	6		X		X
196	A-40519	Terminal strip, bulkhead	3		X		
196	A-40672	Terminal strip, bulkhead	3				X
197	A-2513-90	Bolt	6		X		
198	A-1638-7	Washer	6		X		
199	A-1638-4	Washer	2		X		
200	A-40137	Spacer	1		X		
201	A-40658	Spacer (Cessna 206)	1		X		
201	A-40658-1	Spacer (Cessna T182T)	1		X		
202	A-2513-93	Bolt	1		X		

McCAULEY PROPELLER SYSTEMS
OWNER/OPERATOR
INFORMATION MANUAL

C591

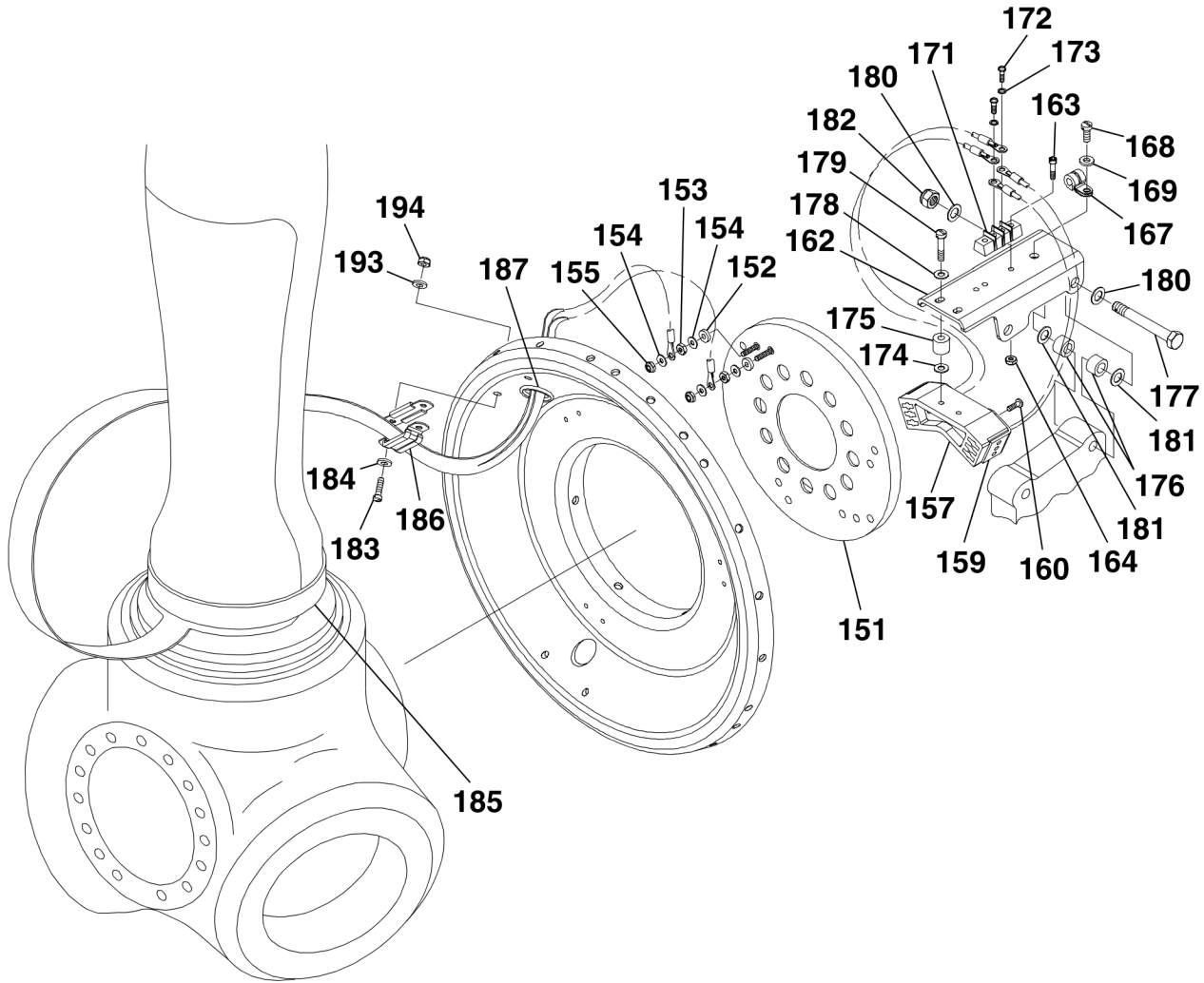

0101T1100

McCauley Installed De-Ice System - C400 Series
Figure 1001 (Sheet 1)

McCAULEY PROPELLER SYSTEMS
OWNER/OPERATOR
INFORMATION MANUAL

C561

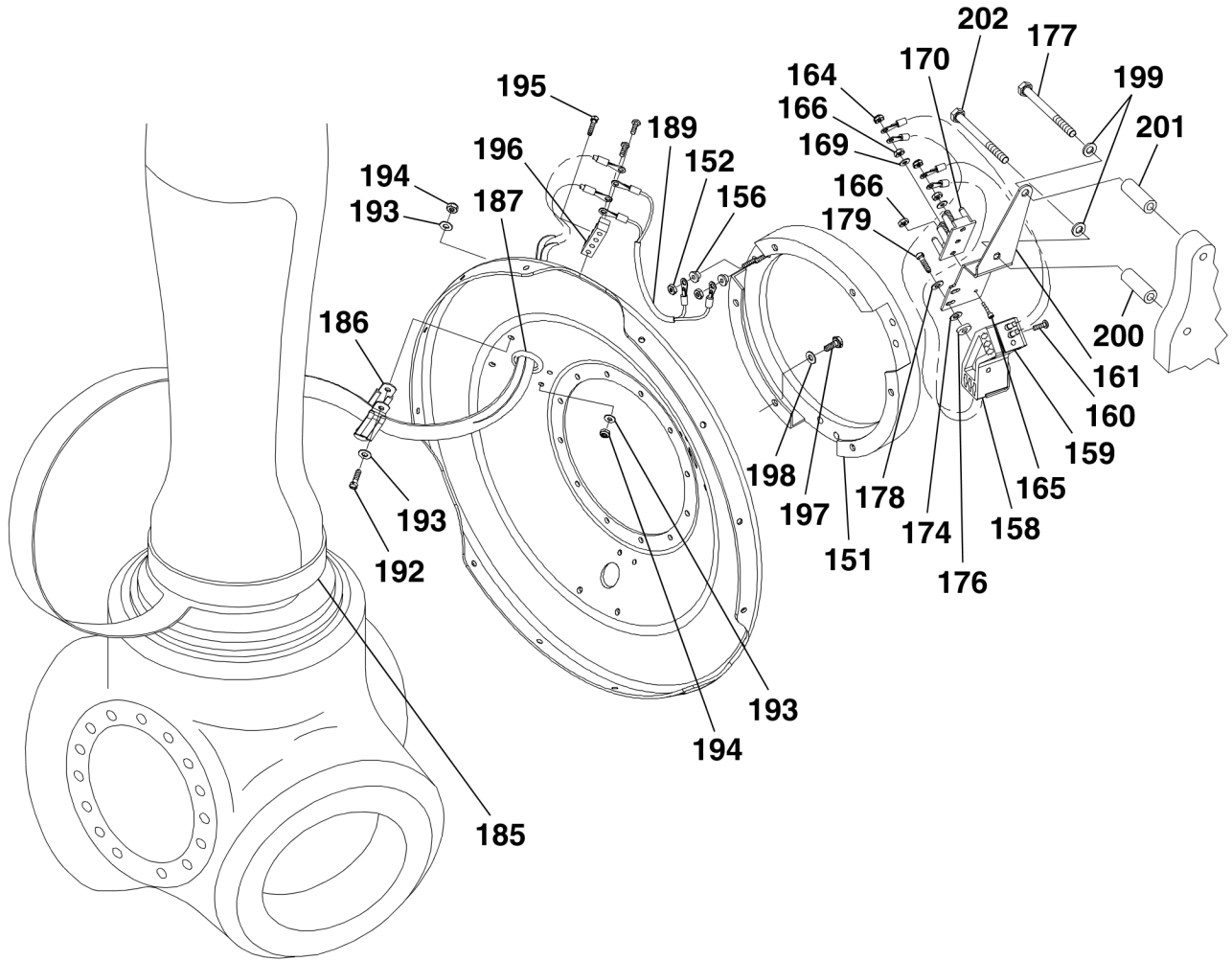

0101T1101

McCauley Installed De-Ice System - C400 Series
Figure 1001 (Sheet 2)

McCAULEY PROPELLER SYSTEMS
OWNER/OPERATOR
INFORMATION MANUAL

C562

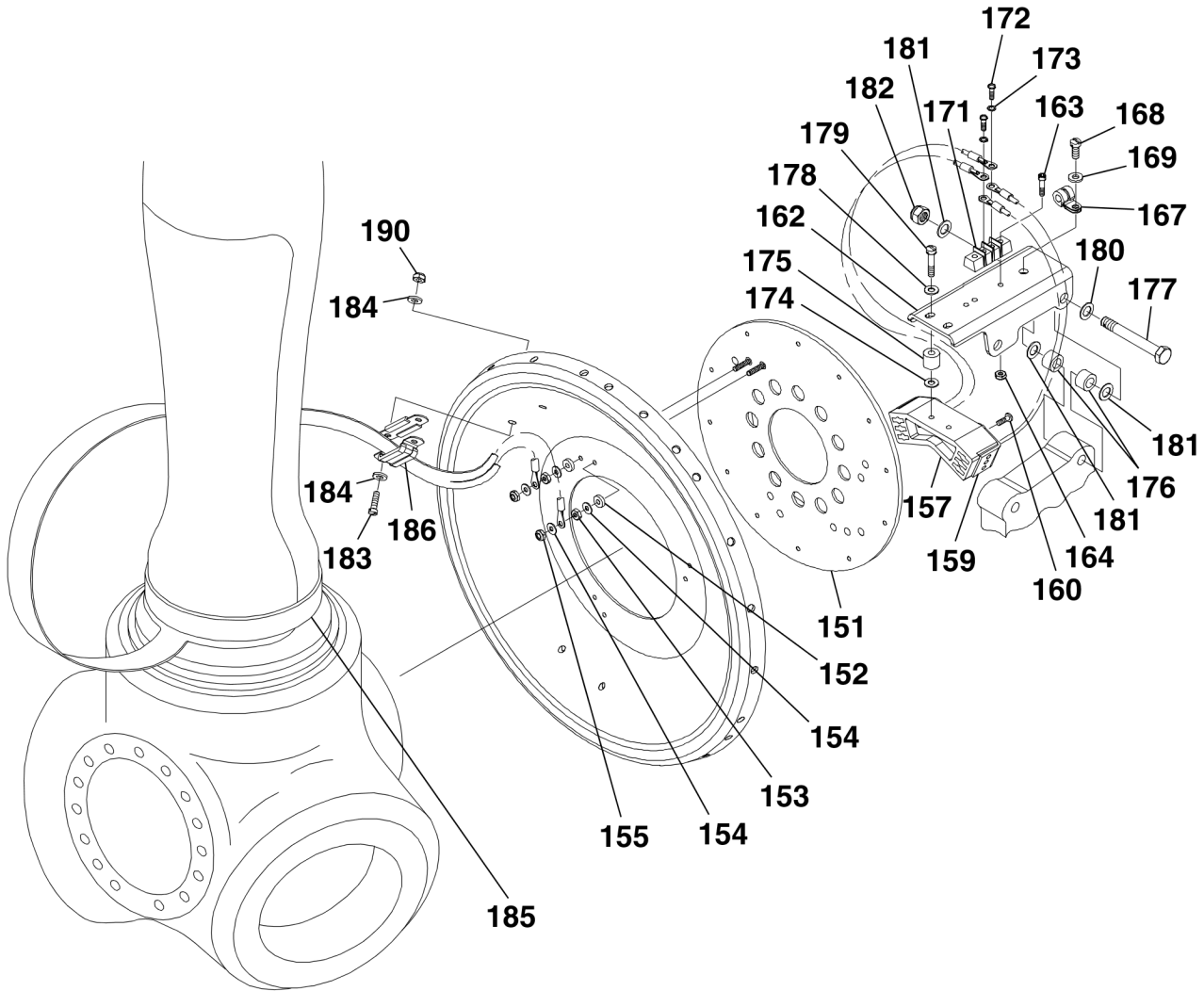

0101T1102

McCauley Installed De-Ice System - C400 Series
Figure 1001 (Sheet 3)

McCAULEY PROPELLER SYSTEMS
OWNER/OPERATOR
 INFORMATION MANUAL

2. Illustrated Deice Parts List C500 Series Propellers

A. An exploded view of a typical C500 Series propeller McCauley supplied deice equipment appears following the Master Deice Parts List (Refer to Tables 1003,1004, and 1005). The index numbers for parts in the illustration are used to identify detail part numbers, assemblies, or groups of similar part numbers in the Parts List.

- (1) Figure1002 illustrates McCauley installed electric deice systems
- (2) Refer to the McCauley Propeller Systems Application Guide (MAG) and the aircraft type certificate data sheet for applications of specific part numbers.

NOTE: This MAG is **not** an FAA approved document, and is for reference only. Refer to the appropriate Type Certificate Data Sheet (TCDS) or Supplemental Type Certificate (STC) to verify information contained in the MAG.

Table 1003. C501, C504, C505, C510, and C511 Propeller Deice Equipment Installation

INDEX NUMBER	PART NUMBER	DESCRIPTION	QTY	C	C	C	C	C	C
				5	5	5	5	5	5
				0	0	0	0	0	0
				1	4	4	5	1	1
				-	-	-	-	-	-
				0	0	0	0	0	0
				X	X	X	X	X	X
				0	1	5	1	1	5
				3	9	2	9	9	2
126	A-1635-63	Screw, boot/harness	6			X			X
126	A-1635-63	Screw, boot/harness	9	X	X		X		
126	A-1635-202*	Screw, boot/harness	6			X			
126	A-1635-202*	Screw, boot/harness	9		X		X	X	
127	A-1638-54	Washer	12			X			X
127	A-1638-54	Washer	18	X	X		X	X	
128	B-5024	Spacer	12						X
128	B-5024	Spacer	18	X	X	X	X	X	
129	A-1639-19	Nut	6			X			X
129	A-1639-19	Nut	9	X	X		X	X	
130	A-1635-203*	Screw, clamp/bracket	3		X	X	X	X	
130	A-1635-14	Screw, clamp/bracket	3	X	X	X	X		X
131	A-2873-5	Clamp	3	X					
131	A-2873-13	Clamp	3		X	X	X	X	X
132	A-1638-25	Washer	3	X	X	X	X	X	X
133	A-1639-51	Nut	3	X	X	X	X	X	X
134	B-4878	Bracket	3		X	X	X		
134	B-5725	Bracket	3						X
134	B-7180*	Bracket	3		X		X	X	
135	A-1635-5**	Screw, bracket/blade	3		X	X	X	X	X

McCAULEY PROPELLER SYSTEMS
OWNER/OPERATOR
 INFORMATION MANUAL

Table 1003. C501, C504, C505, C510, and C511 Propeller Deice Equipment Installation (continued)

INDEX NUMBER	PART NUMBER	DESCRIPTION	QTY	C	C	C	C	C	C
				5	5	5	5	5	5
				0	0	0	0	1	1
				1	4	4	5	0	1
				-	-	-	-	-	-
				0	0	0	0	0	0
				X	X	X	X	X	X
				0	1	5	1	1	5
				3	9	2	9	9	2
135	A-1635-5**	Screw, bracket/blade	6	X					
136	B-40183-3	Boot	3	X					
136	B-40183-19	Boot	3		X		X	X	
136	B-40245-52	Boot	3			X			X
* Low profile hardware									
** Attaching screw for bracket to blade when no balance weights are attached									

Table 1004. Electric Deice C512, C514, C515, C516, and C521 Propeller Deice Equipment Installation

INDEX NUMBER	PART NUMBER	DESCRIPTION	QTY	C	C	C	C	C	C
				5	5	5	5	5	5
				1	1	1	1	1	2
				2	2	4	5	6	1
				-	-	-	-	-	-
				0	0	0	0	0	0
				X	X	X	X	X	X
				5	1	0	1	1	1
				2	8	3	9	9	8
126	A-1635-63	Screw, boot/harness	6	X		X			
126	A-1635-63	Screw, boot/harness	9		X		X		X
126	A-1635-202*	Screw, boot/harness	9				X	X	
127	A-1638-54	Washer	12	X		X			
127	A-1638-54	Washer	18		X		X	X	X
128	B-5024	Spacer	12	X		X			
128	B-5024	Spacer	18		X		X	X	X
129	A-1639-19	Nut	6	X		X			
129	A-1639-19	Nut	9		X		X	X	X
130	A-1635-203*	Screw, clamp/bracket	3		X			X	
130	A-1635-14	Screw, clamp/bracket	3	X	X	X	X		X
131	A-2873-9	Clamp	3			X			
131	A-2873-13	Clamp	3	X	X		X	X	X
132	A-1638-25	Washer	3	X	X	X	X	X	X
133	A-1639-51	Nut	3	X	X	X	X	X	X

McCAULEY PROPELLER SYSTEMS
OWNER/OPERATOR
 INFORMATION MANUAL

Table 1004. Electric Deice C512, C514, C515, C516, and C521 Propeller Deice Equipment Installation (continued)

INDEX NUMBER	PART NUMBER	DESCRIPTION	QTY	C	C	C	C	C	C
				5	5	5	5	5	5
				1	1	1	1	1	1
				2	2	4	5	6	2
				-	-	-	-	-	1
				0	0	0	0	0	0
				X	X	X	X	X	X
				5	1	0	1	1	1
				2	8	3	9	9	8
134	B-4878	Bracket	3		X	X	X		
134	B-5725	Bracket	3	X					X
134	B-7180*	Bracket	3		X			X	
135	A-1635-5**	Screw, bracket/blade	3	X	X	X	X	X	X
136	B-40183-3	Boot	3			X			
136	B-40183-18	Boot	3		X				X
136	B-40183-19	Boot	3				X	X	
136	B-40245-52	Boot	3	X					
	* Low profile hardware								
	** Attaching screw for bracket to blade when no balance weights are attached								

Table 1005. C521, C525, C526, C527, and C528 Propeller Deice Equipment Installation

INDEX NUMBER	PART NUMBER	DESCRIPTION	QTY	C	C	C	C	C
				5	5	5	5	5
				2	2	2	2	2
				1	5	6	7	8
				-	-	-	-	-
				0	0	0	0	0
				X	X	X	X	X
				5	1	5	5	1
				2	9	6	6	9
126	A-1635-63	Screw, boot/harness	6	X				
126	A-1635-63	Screw, boot/harness	9		X			
126	A-1635-202*	Screw, boot/harness	9					X
127	A-1638-54	Washer	12	X				
127	A-1638-54	Washer	18		X			X
128	B-5024	Spacer	12	X				
128	B-5024	Spacer	18		X			X
129	A-1639-19	Nut	6	X				
129	A-1639-19	Nut	9		X			X
130	A-1635-203*	Screw, clamp/bracket	3					X
130	A-1635-14	Screw, clamp/bracket	3	X	X			

McCAULEY PROPELLER SYSTEMS
OWNER/OPERATOR
 INFORMATION MANUAL

Table 1005. C521, C525, C526, C527, and C528 Propeller Deice Equipment Installation (continued)

INDEX NUMBER	PART NUMBER	DESCRIPTION	QTY	C	C	C	C	C
				5	5	5	5	5
				2	2	2	2	2
				1	5	6	7	8
				-	-	-	-	-
				0	0	0	0	0
				X	X	X	X	X
				5	1	5	5	1
				2	9	6	6	9
131	A-2873-13	Clamp	3	X	X			X
132	A-1638-25	Washer	3	X	X			X
133	A-1639-51	Nut	3	X	X			X
134	B-4878	Bracket	3		X	X		
134	B-4971	Bracket	3				X	
134	B-5725	Bracket	3	X				
134	B-7180*	Bracket	3					X
135	A-1635-5**	Screw, bracket/blade	3	X	X	X	X	X
136	B-40183-19	Boot	3		X			X
136	B-40245-52	Boot	3	X				
136	B-40245-56	Boot	3			X	X	
	* Low profile hardware							
	** Attaching screw for bracket to blade when no balance weights are attached							

McCAULEY PROPELLER SYSTEMS
OWNER/OPERATOR
INFORMATION MANUAL

C78

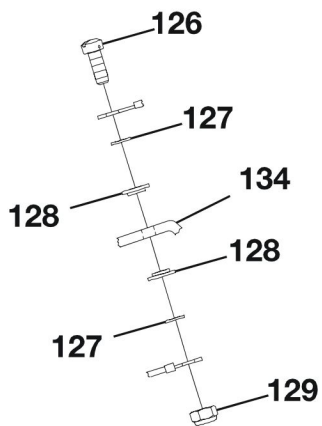
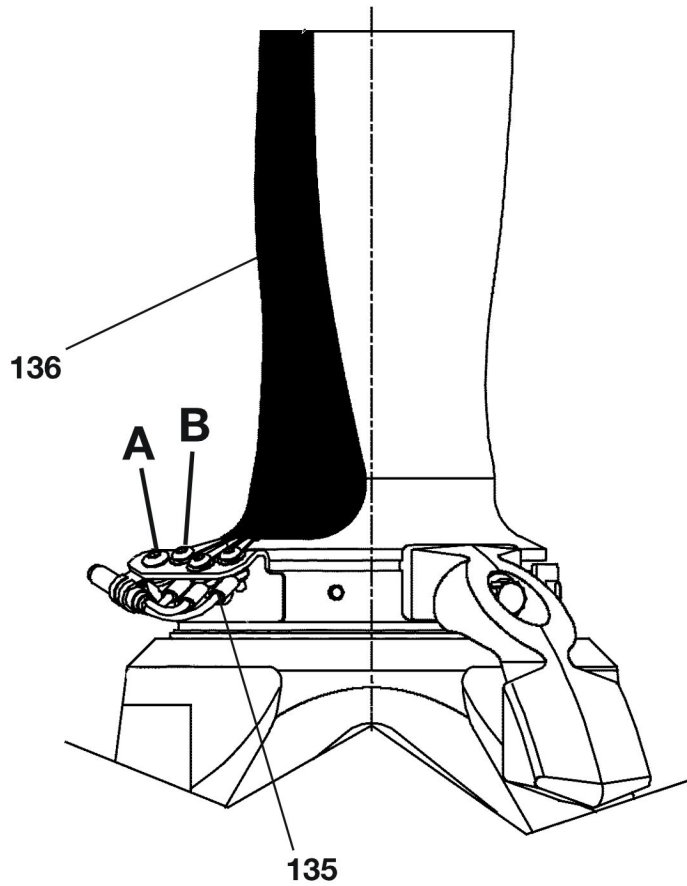

DETAIL B

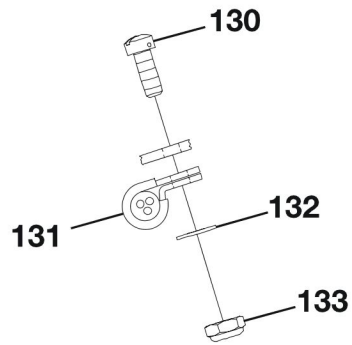

DETAIL A

McCauley Installed De-Ice System - C500 Series
Figure 1002 (Sheet 1)

McCAULEY PROPELLER SYSTEMS
OWNER/OPERATOR
 INFORMATION MANUAL

3. Illustrated Deice Parts List C600 Series Propellers

A. An exploded view of a typical C600 Series propeller McCauley supplied deice equipment appears following the Master Deice Parts List (Refer to Table 1006). The index numbers for parts in the illustration are used to identify detail part numbers, assemblies, or groups of similar part numbers in the Parts List.

- (1) Figure 1003 illustrates McCauley installed electric deice systems
- (2) Refer to the McCauley Propeller Systems Application Guide (MAG) and the aircraft type certificate data sheet for applications of specific part numbers.

NOTE: This MAG is **not** an FAA approved document, and is for reference only. Refer to the appropriate Type Certificate Data Sheet (TCDS) or Supplemental Type Certificate (STC) to verify information contained in the MAG.

Table 1006. C600 Series Propeller Deice Equipment Installation

INDEX NUMBER	PART NUMBER	DESCRIPTION	QTY
251	C-40187	Brush block assembly	1
252	C-40151	..Brush block	1
253	B-40193	..Brush and holder assembly	2
254	A-1635-127	..Screw, brush and holder to block	2
255	B-40024-5	Brush block spacers	2
256	A-1638-21	Washer, brush block to bracket	AR
257	A-1635-70	Screw, bracket to brush block	2
258	A-1638-7	Washer, bracket to brush block	2
259	C-40126	Bracket assembly	1
260	C-40125	..Bracket	1
261	A-1635-139	..Screw	2
262	A-1639-19	..Nut	2
263	A-40373	..Terminal	1
264	A-40224	..Terminal strip	1
265	A-1635-148	..Screw	3
266	A-20582-3	..Lock washer	3
267	A-1635-14	Screw, clamp to bracket	3
268	A-1638-25	Washer, clamp to bracket	3
269	A1639-51	Nut	3
270	A-2873-9	Clamp, harness	3
271	B-5051	Wiring harness	3
272	A-1635-63	Screw, boot and harness lead to bracket	9

McCAULEY PROPELLER SYSTEMS
OWNER/OPERATOR
 INFORMATION MANUAL

Table 1006. C600 Series Propeller Deice Equipment Installation (continued)

INDEX NUMBER	PART NUMBER	DESCRIPTION	QTY
273	A-1638-17	Washer, leads to bracket	18
274	B-5024	Spacer, insulator	18
275	A1639-19	Nut	9
276	A-2873-6	Clamp	3
277	A-1638-19	Washer, clamp to bulkhead	6
278	A-1635-122	Screw, clamp to bulkhead	6
279	D-40099	Deice slip ring assembly	1
280	A-40008	..Washer, phenolic	9
281	A-1638-17	..Washer	18
282	A-1639-19	..Nut	9
283	A-1639-18	..Nut	9

McCAULEY PROPELLER SYSTEMS
OWNER/OPERATOR
INFORMATION MANUAL

C532

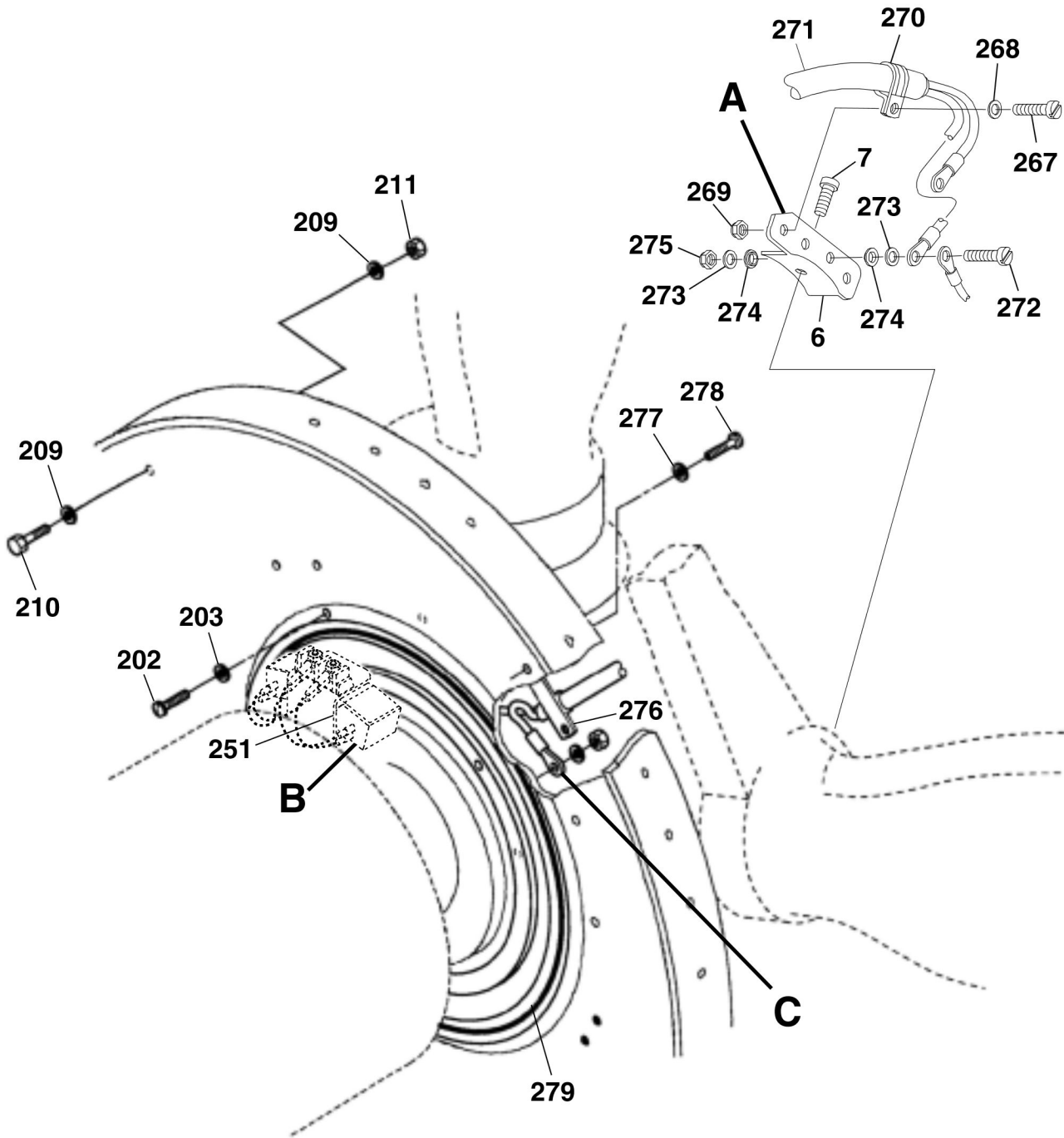

0101T1089

McCauley Installed De-Ice System - C600 Series
Figure 1003 (Sheet 1)

McCAULEY PROPELLER SYSTEMS
OWNER/OPERATOR
 INFORMATION MANUAL

C533

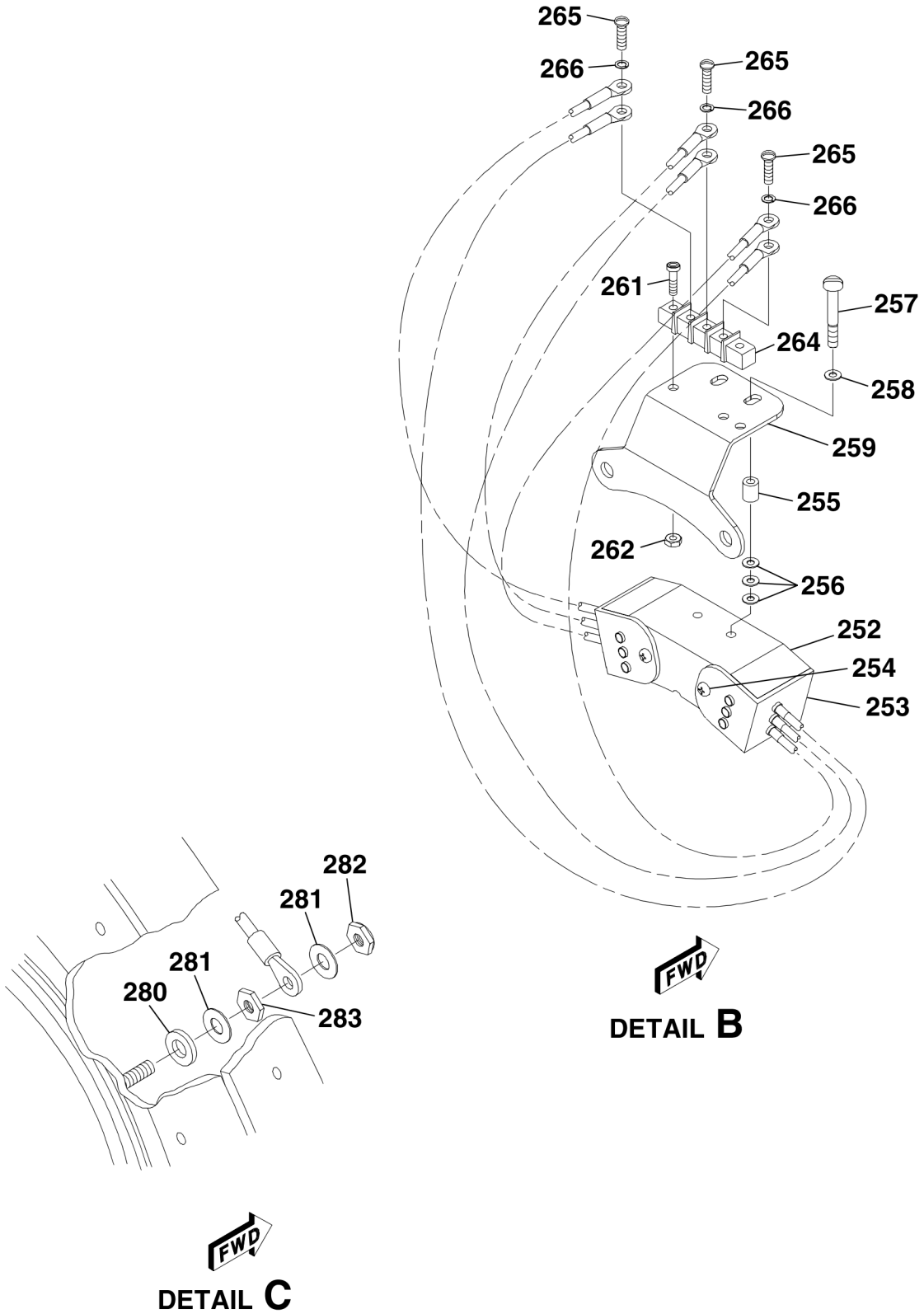

0101T1090

McCauley Installed De-Ice System - C600 Series
 Figure 1003 (Sheet 2)

McCAULEY PROPELLER SYSTEMS
OWNER/OPERATOR
 INFORMATION MANUAL

4. Illustrated Deice Parts List C650 Series Propellers

A. An exploded view of a typical C650 Series propeller McCauley supplied deice equipment appears following the Master Deice Parts List (Refer to Tables 1007 and 1008). The index numbers for parts in the illustration are used to identify detail part numbers, assemblies, or groups of similar part numbers in the Parts List.

- (1) Figure 1004 illustrates McCauley installed electric deice systems
- (2) Refer to the McCauley Propeller Systems Application Guide (MAG) and the aircraft type certificate data sheet for applications of specific part numbers.

NOTE: The MAG is **not** an FAA approved document, and is for reference only. Refer to the appropriate Type Certificate Data Sheet (TCDS) or Supplemental Type Certificate (STC) to verify information contained in the MAG.

Table 1007. C650 Series Propeller Deice Equipment Installation

INDEX NUMBER	PART NUMBER	DESCRIPTION	QTY	C	C	C	C
				6	6	6	6
				5	5	5	5
				2	2	3	3
				-	-	-	-
				0	0	0	0
				4	3	1	4
				0	0	0	5
				7	7	7	5
	B-40183-07	Deice Boot	4	X	X	X	
	B-40183-55	Deice Boot	4				X
251	C-40543	Brush block assembly	1				X
251	C-40331	Brush block assembly	1	X	X	X	
252	C-40562	..Brush block	1				X
252	C-40151	..Brush block	1	X	X	X	
253	B-40332	..Brush and holder assembly	2	X	X	X	
253	B-40415	..Brush and holder assembly	2				X
254	B-40563	..Brush and holder assembly	1				X
255	A-1635-127	..Screw, brush and holder to block	2	X	X	X	
255	A-1635-127	..Screw, brush and holder to block	4				X
256	B-40024-8	Brush block spacers	2		X		
256	B-40024-9	Brush block spacers	2				X
256	B-40024-6	Brush block spacers	2	X		X	
257	A-1638-21	Washer, brush block to bracket	AR	X	X	X	X
258	A-1638-7	Washer, brush block to bracket	2	X	X	X	X
259	A-1635-77	Screw	2	X	X	X	X
260	C-40545	Bracket assembly	1				X
260	C-40597	Bracket assembly	1		X		
260	C-40306	Bracket assembly	1	X		X	

McCAULEY PROPELLER SYSTEMS
OWNER/OPERATOR
 INFORMATION MANUAL

Table 1007. C650 Series Propeller Deice Equipment Installation (continued)

INDEX NUMBER	PART NUMBER	DESCRIPTION	QTY	C	C	C	C
				6	6	6	6
				5	5	5	5
				2	2	3	3
				-	-	-	-
				0	0	0	0
				4	3	1	4
				0	0	0	5
				7	7	7	5
261	C-40548	..Bracket	1				X
261	C-40596	..Bracket	1		X		
261	C-40203	..Bracket	1	X		X	
262	A-1635-146	..Screw	2	X	X	X	X
263	A-1639-43	..Nut	2	X	X	X	X
264	A-40373	..Terminal	1	X	X	X	X
265	A-1638-17	..Washer, terminal	3	X	X	X	X
266	A-1639-18	..Nut, terminal	3	X	X	X	X
267	A-1639-19	..Nut, terminal	3	X	X	X	X
268	A-1635-14	Screw, clamp to bracket	4	X	X	X	X
269	A-1638-25	Washer, clamp to bracket	4	X			X
270	A-2873-9	Clamp, harness	4	X	X	X	X
271	A-1639-51	Nut	4	X	X	X	X
272	B-40387	Wiring harness	4	X	X	X	X
273	A-1635-63	Screw, boot and harness lead to bracket	8	X	X	X	X
274	A-1638-54	Washer, leads to bracket	16	X	X	X	X
275	B-5024	Spacer, insulator	16	X	X	X	X
276	A1639-19	Nut	8	X	X	X	X
278	A-20360-3	Tie strap	8	X	X	X	X
279	A-2873-10	Clamp	4	X	X	X	X
280	A-1635-56	Screw, clamp to bulkhead	8	X	X	X	X
281	A-1638-18	Washer, clamp to bulkhead	8	X	X	X	X
282	D-40354	Deice slip ring assembly	1	X	X	X	X
283	A-40008	..Washer, phenolic	8	X	X	X	X
284	A-1638-17	..Washer	16	X	X	X	X
285	A-1639-18	..Nut	16	X	X	X	X
286	A-1635-15	Screw, slip ring to hub	8	X	X	X	X
287	A1638-25	Washer, slip ring to hub	8	X	X	X	X

McCAULEY PROPELLER SYSTEMS
OWNER/OPERATOR
 INFORMATION MANUAL

Table 1008. C650 Series Propeller Deice Equipment Installation

INDEX NUMBER	PART NUMBER	DESCRIPTION	QTY.	C 6 6 1 - 0 1 5 6	C 6 6 3 - 0 1 0 7	C 6 6 4 - 0 1 0 7	C 6 6 5 - 0 1 5 2
	B-40183-07	Deice Boot	4		X	X	
	B-40245-56	Deice Boot	4	X			
	B-40245-52	Deice Boot	4				X
251	C-40179	Brush block assembly	1	X			
251	C-40331	Brush block assembly	1		X	X	
251	C-40543	Brush block assembly	1				X
252	C-40151	..Brush block	1	X	X	X	
252	C-40562	..Brush block	1				X
253	B-40416	..Brush and holder assembly	2				X
253	B-40189	..Brush and holder assembly	2	X			
253	B-40563	..Brush and holder assembly	1				X
253	B-40332	..Brush and holder assembly	2		X	X	
255	A-1635-127	..Screw, brush and holder to block	2	X	X	X	X
256	B-40024-6	Brush block spacers	2		X	X	
256	B-40024-9	Brush block spacers	2				X
257	A-1638-21	Washer, brush block to bracket	AR	X	X	X	X
257	A-1638-7	Washer, brush block to bracket	2	X	X	X	X
258	A-1635-100	Screw	2	X			
259	A-1635-77	Screw	2		X	X	X
260	C-40306	Bracket assembly	1		X	X	
260	C-40612	Bracket assembly	1	X			
260	C-40545	Bracket assembly	1				X
261	C-40611	..Bracket	1	X			
261	C-40548	..Bracket	1				X
261	C-40203	..Bracket	1		X	X	

McCAULEY PROPELLER SYSTEMS
OWNER/OPERATOR
 INFORMATION MANUAL

Table 1008. C650 Series Propeller Deice Equipment Installation (continued)

INDEX NUMBER	PART NUMBER	DESCRIPTION	QTY.	C	C	C	C
				6	6	6	6
				6	6	6	6
				1	3	4	5
				-	-	-	-
				0	0	0	0
				1	1	1	1
				5	0	0	5
				6	7	7	2
262	A-1635-152	..Screw	2	X			
262	A-1635-146	..Screw	2		X	X	X
263	A-1639-43	..Nut	2	X	X	X	X
264	A-40373	..Terminal	1	X	X	X	X
265	A-1638-17	..Washer, terminal	3	X	X	X	X
266	A-1639-18	..Nut, terminal	3	X	X	X	X
267	A-1639-19	..Nut, terminal	3	X	X	X	X
268	A-1635-14	Screw, clamp to bracket	4		X	X	X
269	A-1638-25	Washer, clamp to bracket	4	X	X	X	X
270	A-2873-13	Clamp, harness	4				X
270	A-2873-9	Clamp, harness	4		X	X	
271	A-1639-51	Nut	4		X	X	X
272	B-40387	Wiring harness	4		X	X	X
272	B-40585	Wiring harness	4	X			
273	A-1635-63	Screw, boot and harness lead to bracket	8		X	X	X
274	A-1638-54	Washer, leads to bracket	16		X	X	X
275	B-5024	Spacer, insulator	16		X	X	X
276	A1639-19	Nut	8		X	X	X
277	A-20360-1	Tie strap	16	X			
278	A-20360-2	Tie strap	8	X			
278	A-20360-3	Tie strap	8		X	X	X
279	A-2873-10	Clamp	4		X	X	X
279	A-2873-5	Clamp	4	X			
280	A-1635-56	Screw, clamp to bulkhead	4	X			
280	A-1635-56	Screw, clamp to bulkhead	8		X	X	X
281	A-1638-18	Washer, clamp to bulkhead	4	X			
281	A-1638-18	Washer, clamp to bulkhead	8		X	X	X
282	D-40354	Deice slip ring assembly	1	X	X	X	X

McCAULEY PROPELLER SYSTEMS
OWNER/OPERATOR
 INFORMATION MANUAL

Table 1008. C650 Series Propeller Deice Equipment Installation (continued)

INDEX NUMBER	PART NUMBER	DESCRIPTION	QTY.	C	C	C	C
				6	6	6	6
				6	6	6	6
				1	3	4	5
				-	-	-	-
				0	0	0	0
				1	1	1	1
				5	0	0	5
				6	7	7	2
283	A-40008	..Washer, phenolic	8	X	X	X	X
284	A-1638-17	..Washer	16	X	X	X	X
285	A-1639-18	..Nut	16	X	X	X	X
286	A-1635-15	Screw, slip ring to hub	8	X	X	X	X
287	A1638-25	Washer, slip ring to hub	8	X	X	X	X

McCAULEY PROPELLER SYSTEMS
OWNER/OPERATOR
INFORMATION MANUAL

C490

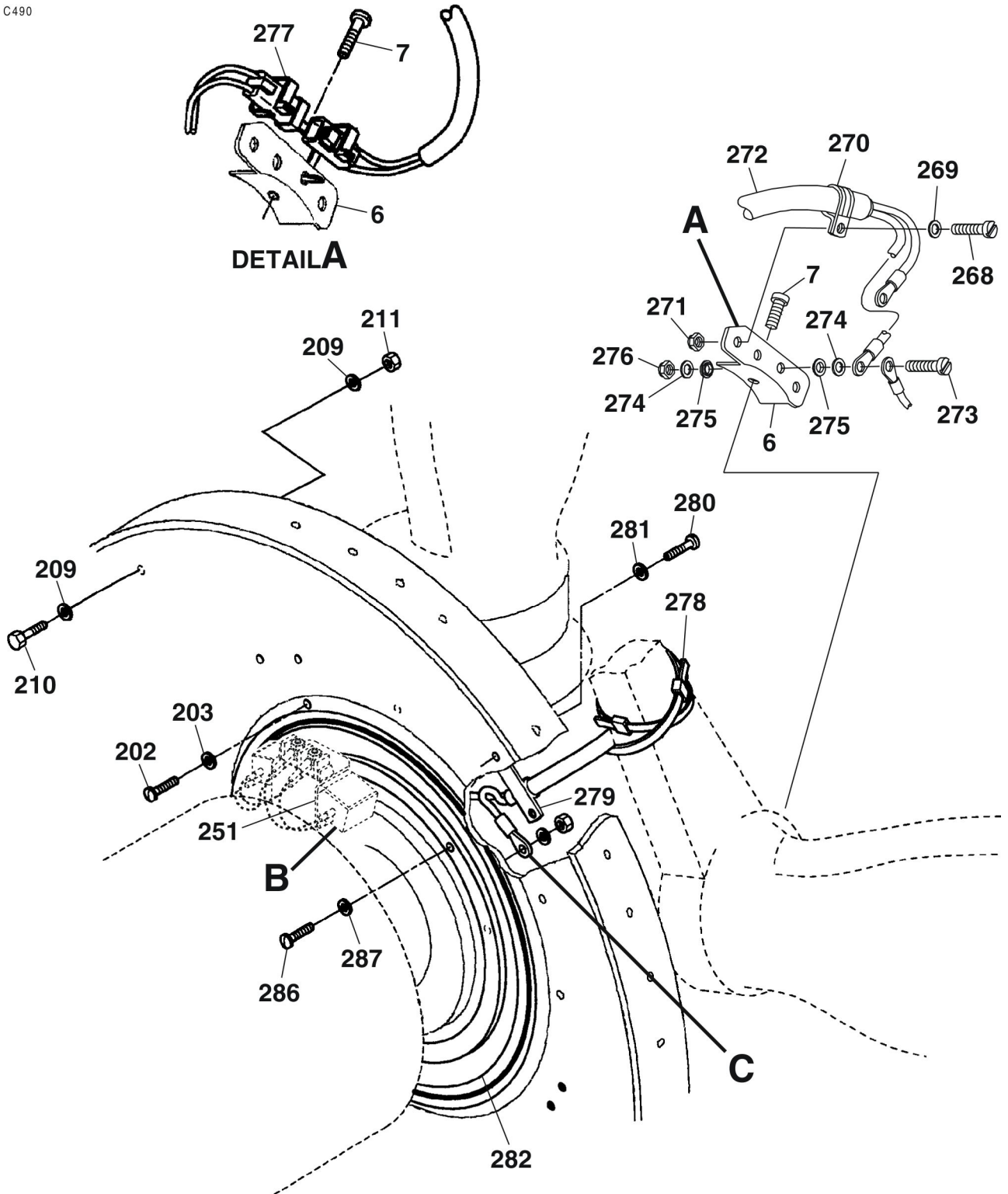

0101T1089

McCauley Installed De-Ice System - C650 Series
Figure 1004 (Sheet 1)

McCAULEY PROPELLER SYSTEMS
OWNER/OPERATOR
 INFORMATION MANUAL

C491

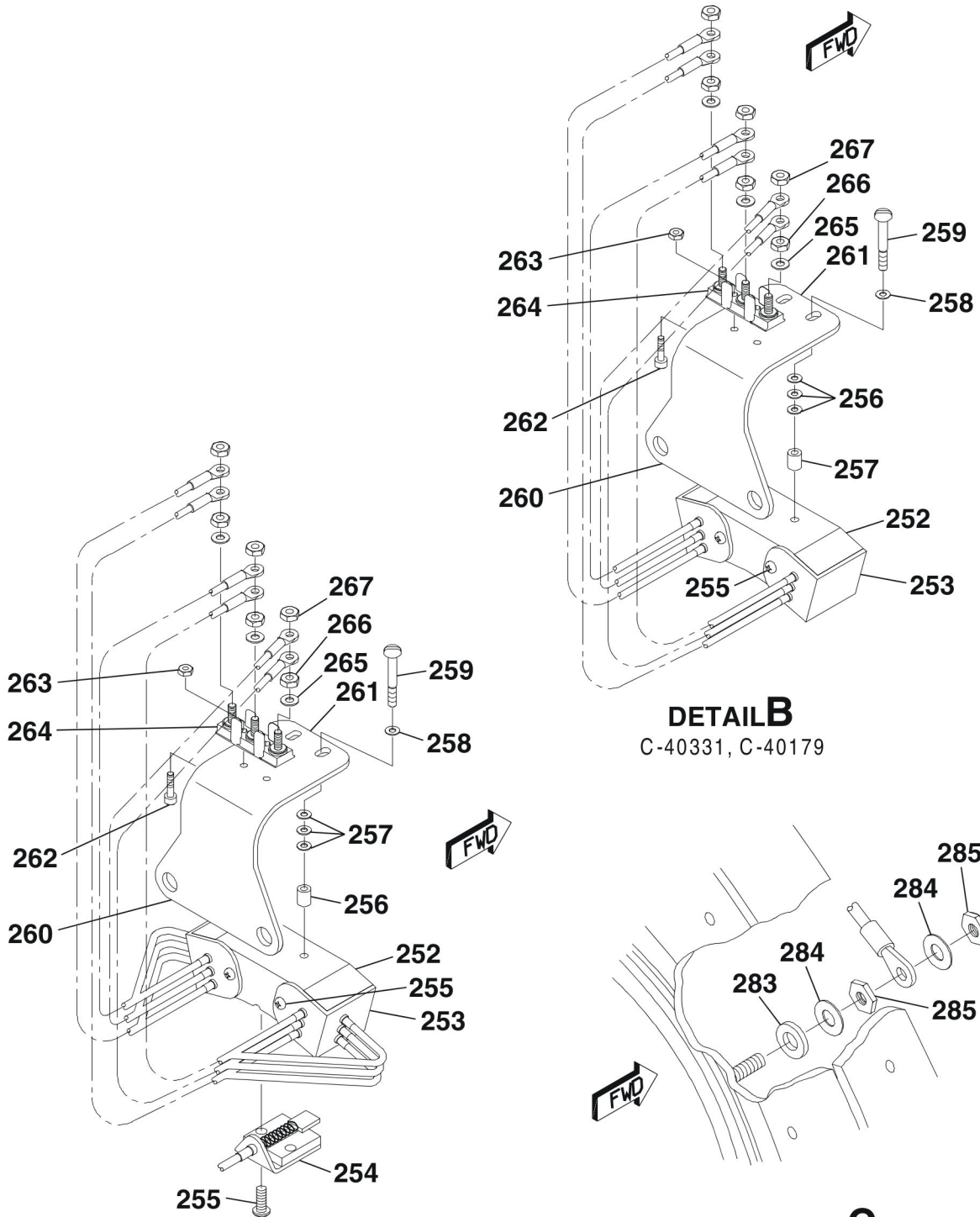

DETAIL B
 C-40543

DETAIL B
 C-40331, C-40179

DETAIL C

McCauley Installed De-Ice System - C650 Series
 Figure 1004 (Sheet 2)

0101T1090

McCAULEY PROPELLER SYSTEMS
OWNER/OPERATOR
 INFORMATION MANUAL

5. Illustrated Deice Parts List C700 Series Propellers

- A. An exploded view of a typical C700 Series propeller McCauley supplied deice equipment appears following the Master Deice Parts List (Refer to Tables 1009 and 1010). The index numbers for parts in the illustration are used to identify detail part numbers, assemblies, or groups of similar part numbers in the Parts List.
- (1) Figure 1005 illustrates McCauley installed electric deice systems
 - (2) Refer to the McCauley Propeller Systems Application Guide (MAG) and the aircraft type certificate data sheet for applications of specific part numbers.

NOTE: The MAG is **not** an FAA approved document, and is for reference only. Refer to the appropriate Type Certificate Data Sheet (TCDS) or Supplemental Type Certificate (STC) to verify information contained in the MAG.

Table 1009. C750 Series Propeller De-Ice Boot Installation

PART NUMBER	DESCRIPTION	QTY	C 7 0 3 - 0 C 7 0 4			
			A	B	2	X
B-40245-50	Boot	3			X	
B-40245-54	Boot	3				X
B-40183-06	Boot (not procurable)	3	X			
B-40183-03	Boot	3	X	X		X

Table 1010. C700 Series Propeller Deice Equipment

INDEX NUMBER	PART NUMBER	DESCRIPTION	QTY	C 7 0 1 C 7 0 2 C 7 0 3 C 7 0 4			
				X	X	X	X
251	C-40179	Brush block assembly	1	X			X
251	C-40257	Brush block assembly	1		X	X	
252	B-40189	Brush and holder assembly	2	X			X
252	C-40256-1	Brush and holder assembly (right)	1		X	X	
252	C-40256-2	Brush and holder assembly (left)	1		X	X	
253	C-40151	Brush block	1	X	X	X	X
254	B-40024-9	Brush block spacers	2	X	X	X	X
255	A-1638-21	Washer, brush block to bracket	12	X	X	X	X
255A	A-1638-7	Washer, brush block to bracket	2	X	X	X	X
256	A-1635-127	Screw, brush and holder to block	2	X	X	X	X
257	A-1635-77	Screw, brush block to bracket	2	X	X	X	X

McCAULEY PROPELLER SYSTEMS
OWNER/OPERATOR
INFORMATION MANUAL

Table 1010. C700 Series Propeller Deice Equipment (continued)

INDEX NUMBER	PART NUMBER	DESCRIPTION	QTY	C	C	C	C
				701	702	703	704
258	C-40537	Bracket assembly	1	X			X
258	C-40536	Bracket assembly	1		X	X	
259	C-40538	..Bracket	1	X	X	X	X
260	A-1635-146	..Screw	2	X	X	X	X
261	A-40476	..Terminal	1		X	X	
261	A-40373	..Terminal	1	X			X
262	A-1639-43	..Nut	2	X	X	X	X
263	A-1638-17	..Washer, terminal	2		X	X	
263	A-1638-17	..Washer, terminal	3	X			X
264	A-1639-18	..Nut, terminal	2		X	X	
264	A-1639-18	..Nut, terminal	3	X			X
264A	A-1639-19	..Nut, terminal	2		X	X	
264A	A-1639-19	..Nut, terminal	3	X			X
265	A-2873-6	Clamp, harness to bulkhead	3		X	X	
265	A-2873-10	Clamp, harness to bulkhead	3	X			X
266	A-1635-56	Screw, clamp to bulkhead	3		X	X	
266	A-1635-122	Screw, clamp to bulkhead	6	X			X
267	A-1638-18	Washer, clamp to bulkhead	3		X	X	
267	A-1638-19	Washer, clamp to bulkhead	6	X			X
268	B-5051	Wire harness	3	X			X
268	B-40276	Wire harness	3		X		
268	B-40531	Wire harness	3			X	
269	A-20360-3	Tie wrap, harness to counterweight	6			X	
270	A-2873-5	Clamp	3	X			X
270	A-2873-9	Clamp	3		X		
271	A-1635-14	Screw, clamp to bracket	3	X	X		X
272	A-1638-25	Washer, clamp to bracket	3	X	X		X
273	A-1639-51	Nut, clamp to bracket	3	X	X		X
274	A-1635-63	Screw, boot/harness to bracket	6		X		
274	A-1635-63	Screw, boot/harness to bracket	9	X			X
275	A-1638-17	Washer, boot/harness to bracket	12		X		
275	A-1638-17	Washer, boot/harness to bracket	18	X			X

McCAULEY PROPELLER SYSTEMS
OWNER/OPERATOR
 INFORMATION MANUAL

Table 1010. C700 Series Propeller Deice Equipment (continued)

INDEX NUMBER	PART NUMBER	DESCRIPTION	QTY	C 7 0 1	C 7 0 2	C 7 0 3	C 7 0 4
276	B-5024	Insulator	12		X		
276	B-5024	Insulator	18	X			X
277	A-1639-19	Nut, boot/harness to bracket	6		X		
277	A-1639-19	Nut, boot/harness to bracket	9	X			X
278	A-20560-1	Tie wrap, harness/boot to bracket	12			X	
280	A-40008	Washer, phenolic	6		X	X	
280	A-40008	Washer, phenolic	9	X			X
281	A-1638-17	Washer	12		X	X	
281	A-1638-17	Washer	18	X			X
282	A-1639-18	Nut	6		X	X	
282	A-1639-18	Nut	9	X			X
283	A-1639-19	Nut	6		X	X	
283	A-1639-19	Nut	9	X			X

McCAULEY PROPELLER SYSTEMS
OWNER/OPERATOR
INFORMATION MANUAL

C368

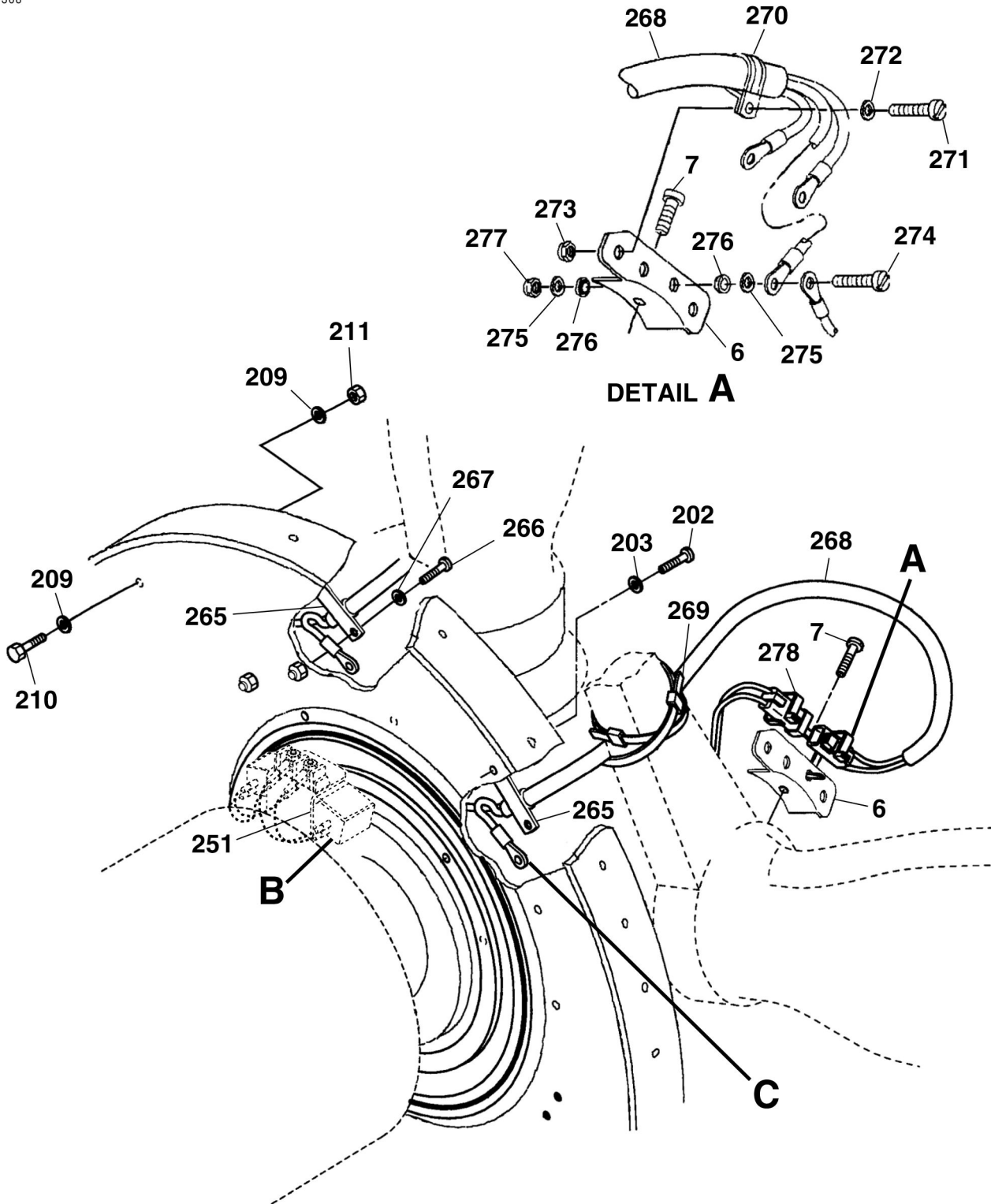

0101R1089

McCauley Installed De-Ice System - C700 Series
Figure 1005 (Sheet 1)

McCAULEY PROPELLER SYSTEMS
OWNER/OPERATOR
INFORMATION MANUAL

C471

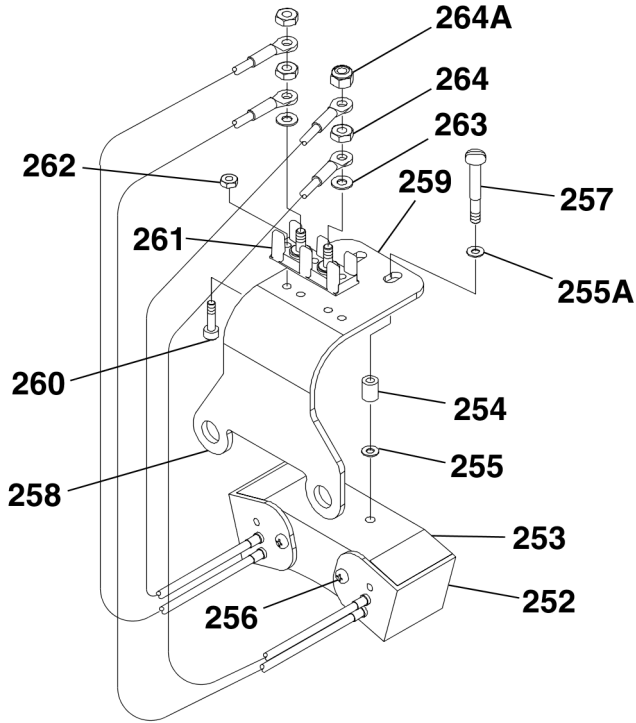

DETAIL B

C-40179, C-40257

NOTE: C-40179 HAS 3 BRUSHES/LEADS.

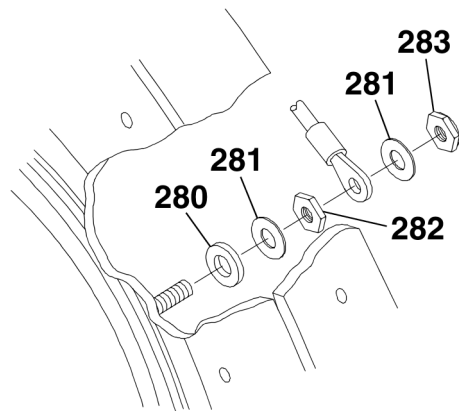

DETAIL C

B1214T1076
C1214T1076

McCauley Installed De-Ice System - C700 Series
Figure 1005 (Sheet 2)

McCAULEY PROPELLER SYSTEMS
OWNER/OPERATOR
 INFORMATION MANUAL

6. Illustrated Deice Parts List C750 Series Propellers

A. An exploded view of a typical C750 Series propeller McCauley supplied deice equipment appears following the Master Deice Parts List (Refer to Tables 1011 and 1012). The index numbers for parts in the illustration are used to identify detail part numbers, assemblies, or groups of similar part numbers in the Parts List.

- (1) Figure 1006 illustrates McCauley installed electric deice systems.
- (2) Refer to the McCauley Propeller Systems Application Guide (MAG) and the aircraft type certificate data sheet for applications of specific part numbers.

NOTE: The MAG is **not** an FAA approved document, and is for reference only. Refer to the appropriate Type Certificate Data Sheet (TCDS) or Supplemental Type Certificate (STC) to verify information contained in the MAG.

Table 1011. C750 Series Propeller Deice Boot Installation.

PART NUMBER	DESCRIPTION	QT-Y	C	C	C	C	C	C	C	C	C	C	C	C	C	C	C	C
			7	7	7	7	7	7	7	7	7	7	7	7	7	7	7	7
			5	5	6	6	6	6	6	6	6	7	7	7	7	7	7	7
			4	8	0	2	3	4	6	8	9	1	3	4	5	0	0	0
B-40245-52	Deice boot	4	X		X	X	X	X	X								X	
B-40245-54	Deice boot	4		X										X				
B-40245-56	Deice boot	4								X	X	X	X					
B-40183-20	Deice boot	4												X		X		
B-40183-22	Deice boot	4																X

Table 1012. C750 Series Propeller Deice Equipment.

INDEX NUMBER	PART NUMBER	DESCRIPTION	QTY	C	C	C	C	C	C	C	C	C	C	C	C	C	C	C
				7	7	7	7	7	7	7	7	7	7	7	7	7	7	7
				5	5	6	6	6	6	6	6	6	6	7	7	7	7	7
				4	8	0	2	3	4	6	8	9	1	3	4	5	9	
251	C-40257	Brush block assembly	1	X		X	X	X					X			X	X	
251	C-40463	Brush block assembly	1		X													
251	D-40179	Brush block assembly	1							X		X		X	X			
251	C-40257	Brush block assembly	1								X							
252	B-40189	..Brush and holder assembly	2	X						X		X		X	X			
252	C-40256-2	..Brush and holder assembly, left	1			X	X	X			X		X			X	X	
252	C-40256-1	..Brush and holder assembly, right	1			X	X	X			X		X			X	X	
252	C-40464-1	..Brush and holder assembly, left	1		X													

McCAULEY PROPELLER SYSTEMS
OWNER/OPERATOR
 INFORMATION MANUAL

Table 1012. C750 Series Propeller Deice Equipment. (continued)

INDEX NUMBER	PART NUMBER	DESCRIPTION	QTY	C	C	C	C	C	C	C	C	C	C	C	C	C	C
				7 5 4	7 5 8	7 6 0	7 6 2	7 6 3	7 6 4	7 6 6	7 6 8	7 7 9	7 7 1	7 7 3	7 7 4	7 7 5	7 7 9
252	C-40464-2	..Brush and holder assembly, right	1		X												
253	C-40151	..Brush block	1	X					X	X		X	X				X
254	B-40024-8	..Brush block spacers	2		X												
254	B-40024-9	..Brush block spacers	2	X		X	X	X		X	X	X	X	X	X	X	X
255	A-1638-21	Washer, brush block to bracket	AR	X	X	X	X	X		X	X	X	X	X	X	X	X
255A	A-1638-7	Washer, brush block to bracket	2	X	X	X	X	X		X	X	X	X	X	X	X	X
256	A-1635-127	Screw, brush and holder to block	2	X	X	X	X	X		X	X	X	X	X	X	X	X
257	A-1635-77	Screw, brush block to bracket	2	X	X	X	X	X		X	X	X	X	X	X	X	X
258	C-40448	Bracket assembly	1		X												
258	C-40536	Bracket assembly	1	X		X	X	X		X		X				X	
258	C-40537	Bracket assembly	1						X	X		X	X				
259	C-40475	..Bracket	1		X												
259	C-40538	..Bracket	1	X		X	X	X		X	X	X	X	X	X	X	X
*	C-40816	Bracket	1														X
*	C-40817	Bracket Assy - Brush Block	1														X
260	A-1635-146	..Screw, terminal strip attach	2	X	X	X	X	X		X	X	X	X	X	X	X	X
261	A-40476	..Terminal	1	X	X	X	X	X		X		X				X	X
261	A-40373	..Terminal	1						X	X		X	X				
262	A-1639-43	..Nut	2	X	X	X	X	X		X	X	X	X	X	X	X	X
263	A-1638-17	..Washer, terminal	2	X	X	X	X	X		X		X				X	X
263	A-1638-17	..Washer, terminal	3						X	X		X	X				
264	A-1639-18	..Nut	2	X	X	X	X	X		X		X				X	X
264	A-1639-18	..Nut	3						X	X		X	X				
264A	A-1639-19	..Nut	2	X	X	X	X	X		X		X				X	X
264A	A-1639-19	..Nut	3						X	X		X	X				
265	A-2873-10	Clamp, harness to bulkhead	4	X		X	X	X	X	X		X		X	X	X	X
265	A-2873-5	Clamp, harness to bulkhead	4		X						X		X				
*	A-1635-5	Screw	4														X

McCAULEY PROPELLER SYSTEMS
OWNER/OPERATOR
 INFORMATION MANUAL

Table 1012. C750 Series Propeller Deice Equipment. (continued)

INDEX NUMBER	PART NUMBER	DESCRIPTION	QTY	C	C	C	C	C	C	C	C	C	C	C	C	C
				7 5 4	7 5 8	7 6 0	7 6 2	7 6 3	7 6 4	7 6 6	7 6 8	7 6 9	7 7 1	7 7 3	7 7 4	7 7 5
266	A-1635-56	Screw, clamp to bulkhead	4		X						X	X				X
266	A-1635-56	Screw, clamp to bulkhead	8	X		X	X	X	X	X		X		X	X	X
*	A-1635-99	Screw	2													X
267	A-1638-18	Washer, clamp to bulkhead	4		X						X	X				X
267	A-1638-18	Washer, clamp to bulkhead	8	X		X	X	X	X	X		X		X	X	X
268	B-40330	Wire harness	4	X		X	X	X	X	X						
268	B-40452	Wire harness	4		X											X
268	B-40585	Wire harness	4								X	X				
268	B-40668	Wire harness	4											X		
268	B-40585	Wire harness	4								X	X		X		
269	A-20360-3	Tie wrap, harness to counterweight.	8	X		X	X	X	X		X				X	X
269	A-20360-2	Tie wrap, harness to counterweight.	8							X	X		X	X		
*	A-2873-7	Clamp	4													X
270	A-2873-9	Clamp	4	X		X	X	X	X	X					X	
271	A-1635-14	Screw, clamp to bracket	4	X		X	X	X	X	X					X	
272	A-1638-25	Washer, clamp to bracket	4	X		X	X	X	X	X					X	
273	A-1639-51	Nut, clamp to bracket	4	X		X	X	X	X	X					X	
274	A-1635-63	Screw, boot and harness to bracket	8	X		X	X	X	X	X						
274	A-1635-63	Screw, boot and harness to bracket	12											X		
275	A-1638-54	Washer, harness to bracket	16	X		X	X	X		X						
275	A-1638-54	Washer, harness to bracket	24											X		
275	A-1638-17	Washer, boot and harness to bracket	16						X							
*	B-4971	Bracket, De-ice mounting	4													X
276	B-5024	Insulator	16	X		X	X	X	X	X						

McCAULEY PROPELLER SYSTEMS
OWNER/OPERATOR
 INFORMATION MANUAL

Table 1012. C750 Series Propeller Deice Equipment. (continued)

INDEX NUMBER	PART NUMBER	DESCRIPTION	QTY	C	C	C	C	C	C	C	C	C	C	C	C	C	C
				7	7	7	7	7	7	7	7	7	7	7	7	7	7
				5	5	6	6	6	6	6	6	6	6	7	7	7	7
				4	8	0	2	3	4	6	8	9	1	3	4	5	9
276	B-5024	Insulator	24												X		
277	A-1639-19	Nut, boot and harness to bracket	8	X		X	X	X	X	X							
277	A-1639-19	Nut, boot and harness to bracket	12												X		
278	A-20360-1	Tie wrap, harness and boot to bracket	16		X						X	X	X	X		X	X
279	A-40008	Washer, phenolic	8	X	X	X	X	X	X	X	X	X	X	X		X	
279	A-40008	Washer, phenolic	12												X		
280	A-1638-17	Washer	16	X	X	X	X	X	X	X	X	X	X	X		X	
280	A-1638-17	Washer	24												X		
281	A-1639-18	Nut	8	X	X	X	X	X	X	X	X	X	X	X		X	
281	A-1639-18	Nut	12												X		
282	A-1639-19	Nut	8	X	X	X	X	X	X	X	X	X	X	X		X	
282	A-1639-19	Nut	12												X		
*	A-1664-1	Sealant-Loctite Gasket	AR														X
*	A-1664-27	Sealant-Sentry Seal	AR														X

* Item is not currently illustrated.

McCAULEY PROPELLER SYSTEMS
OWNER/OPERATOR
INFORMATION MANUAL

C368

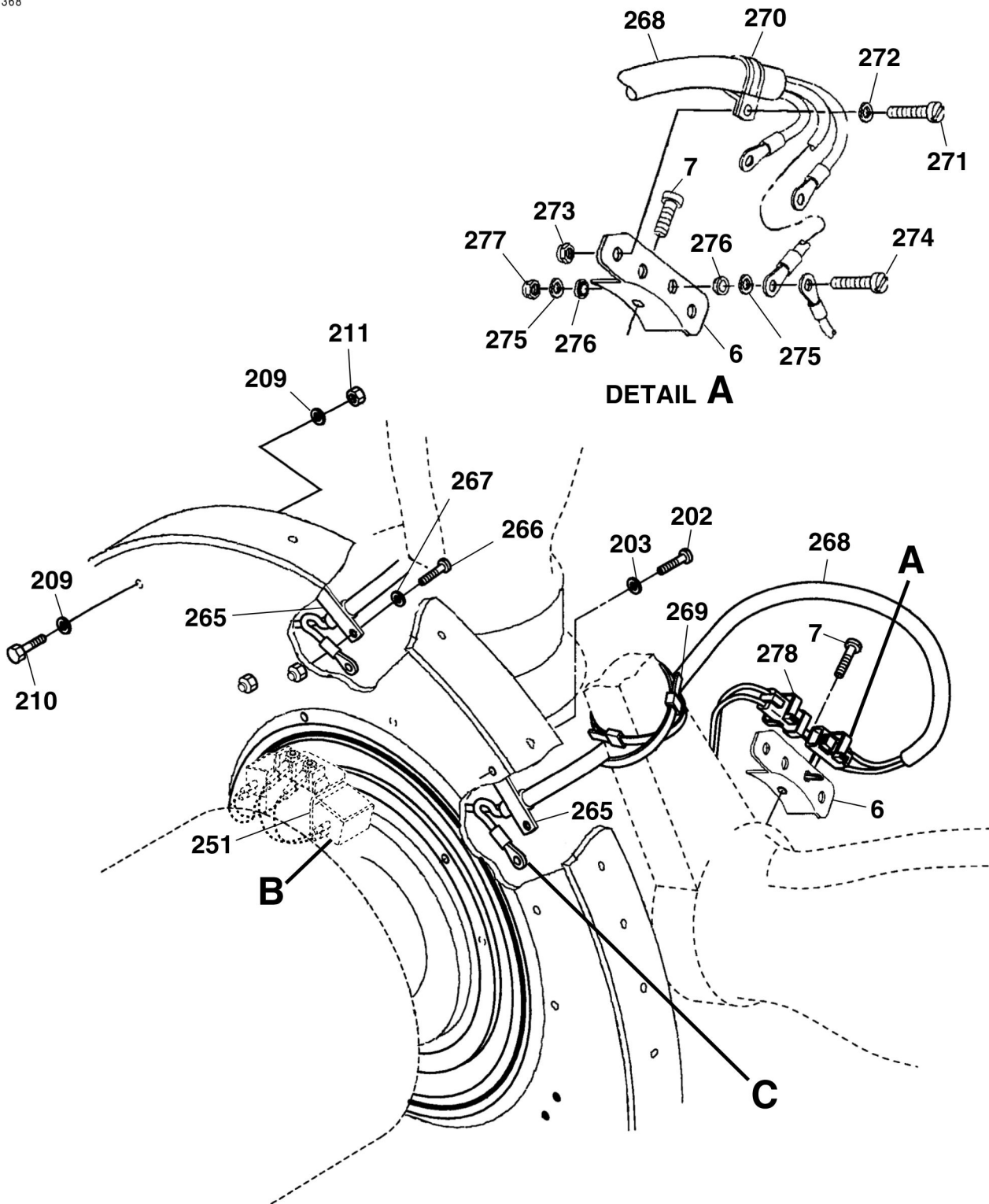

0101R1089

McCauley Installed De-Ice System - C750 Series
Figure 1006 (Sheet 1)

McCAULEY PROPELLER SYSTEMS
OWNER/OPERATOR
 INFORMATION MANUAL

C369

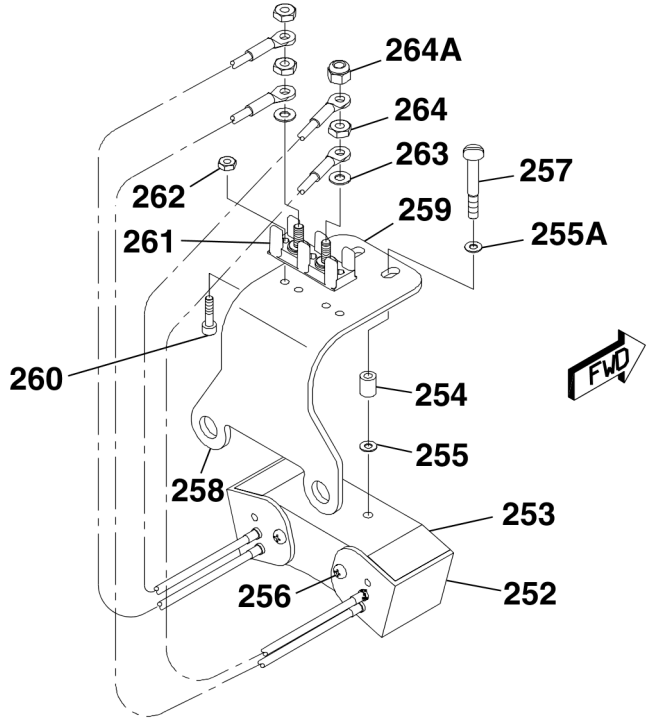

DETAIL B
 C-40179, C-40257

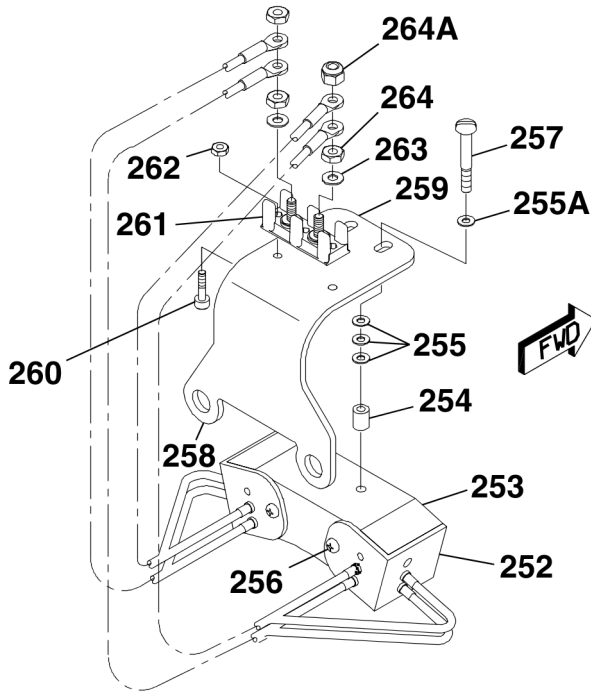

DETAIL B
 C-40463

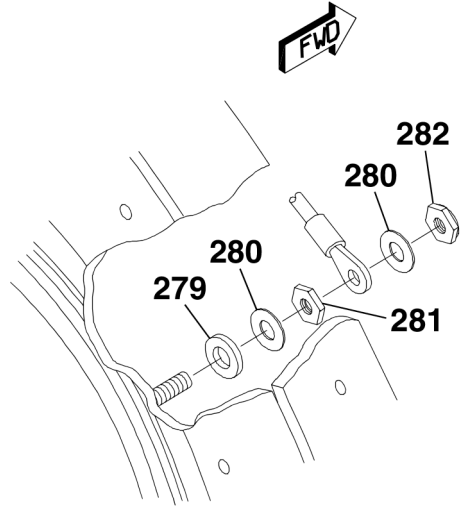

DETAIL C

0101T1090

McCauley Installed De-Ice System - C750 Series
 Figure 1006 (Sheet 2)

McCAULEY PROPELLER SYSTEMS
OWNER/OPERATOR
 INFORMATION MANUAL

7. Illustrated Deice Parts List C1100 Series Propellers

A. An exploded view of a typical C1100 Series propeller McCauley supplied deice equipment appears following the Master Deice Parts List (Refer to Table 1013). The index numbers for parts in the illustration are used to identify detail part numbers, assemblies, or groups of similar part numbers in the Parts List.

- (1) Figure 1007 illustrates McCauley installed electric deice systems
- (2) Refer to the McCauley Propeller Systems Application Guide (MAG) and the aircraft type certificate data sheet for applications of specific part numbers.

NOTE: The MAG is **not** an FAA approved document, and is for reference only. Refer to the appropriate Type Certificate Data Sheet (TCDS) or Supplemental Type Certificate (STC) to verify information contained in the MAG.

Table 1013. C1100 Series Propeller Deice Equipment

INDEX NUMBER	PART NUMBER	DESCRIPTION	QTY	C	C	C	C	C
				1	1	1	1	1
				0	0	0	0	0
				1	2	3	4	5
108	B-40183-16	Right deice boot	5	X		X		
108	B-40183-17	Left deice boot	5		X		X	
108	B-40245-56	Deice boot	5					X
109	A-4634	Balance weight holder gasket	AR	X	X	X	X	X
110	B-4629	Balance weight holder	AR	X	X	X	X	X
110	B-6161	Balance weight holder (optional)	AR	X	X	X	X	X
111	A-4630	Balance weight (8 maximum/holder)	AR	X	X	X	X	X
111	A-4630-1	Balance weight (1 maximum/holder)	AR	X	X	X	X	X
112	A-1635-5	Screw (balance weight) (0.438-inch (11.13 mm) length)	AR	X	X	X	X	X
112	A-1635-14	Screw (balance weight) (0.500-inch (12.70 mm) length)	AR	X	X	X	X	X
112	A-1635-120	Screw (balance weight) (0.563-inch (14.30 mm) length)	AR	X	X	X	X	X
112	A-1635-15	Screw (balance weight) (0.625-inch (15.87 mm) length)	AR	X	X	X	X	X
112	A-1635-121	Screw (balance weight) (0.688-inch (17.47 mm) length)	AR	X	X	X	X	X
112	A-1635-96	Screw (balance weight) (0.750-inch (19.05 mm) length)	AR	X	X	X	X	X
112	A-1635-116	Screw (balance weight) (0.813-inch (20.65 mm) length)	AR	X	X	X	X	X
112	A-1635-54	Screw (balance weight) (0.875-inch (22.22 mm) length)	AR	X	X	X	X	X
112	A-1635-118	Screw (balance weight) (0.938-inch (23.82 mm) length)	AR	X	X	X	X	X

McCAULEY PROPELLER SYSTEMS
OWNER/OPERATOR
 INFORMATION MANUAL

Table 1013. C1100 Series Propeller Deice Equipment (continued)

INDEX NUMBER	PART NUMBER	DESCRIPTION	QTY	C	C	C	C	C
				1	1	1	1	1
				0	0	0	0	0
				1	2	3	4	5
113	B-4971	Bracket (deice mounting)	5	X		X		X
113	B-4878	Bracket (deice mounting)	5		X		X	
114	A-1635-5	Screw (deice mounting)	5	X	X	X	X	X
115	A-20360-1	Tie wrap, boot and harness plugs to bracket	20					X
116	A-1635-205	Screw (boot lead to bracket)	15	X	X	X	X	
117	B-40627	Spacer (insulator)	30	X	X	X	X	
118	A-1639-18	Nut (terminal attachment)	3	X	X	X	X	
119	A-1639-53	Nut (boot lead to bracket)	15	X	X	X	X	
120	A-2873-13	Clamp (harness to blade)	5	X	X	X	X	
121	A-1635-14	Screw (clamp to bracket)	5	X	X	X	X	
122	A-1638-25	Washer (clamp to bracket)	5	X	X	X	X	
123	A-1639-51	Nut (clamp to bracket)	5	X	X	X	X	
124	B-5491	Balance weight and clamp holder	5	X	X	X	X	
125	A-2873-9	Harness clamp	5	X	X	X	X	
126	A-1635-5	Screw, clamp to bracket	5	X	X	X	X	
127	C-40648	Wiring harness	5	X	X	X	X	
127	B-40585	Wiring harness	5					X
128	A-20360-3	Tie wrap	10					X
129	A-2873-15	Clamp (wiring harness to bulkhead)	5	X	X	X	X	
129	A-2873-5	Clamp (wiring harness to bulkhead)	5					X
130	A-1635-56	Screw (clamp to bulkhead)	5					X
130	A-1635-56	Screw (clamp to bulkhead)	10	X	X	X	X	
131	A-1638-18	Washer (clamp to bulkhead)	5					X
131	A-1638-18	Washer (clamp to bulkhead)	10	X	X	X	X	
132	A-1638-17	Washer (slip ring assembly)	10					X
132	A-1638-17	Washer (slip ring assembly)	15	X	X	X	X	
133	A-1639-19	Nut (slip ring assembly)	10					X
133	A-1639-19	Nut (slip ring assembly)	15	X	X	X	X	
134	A-1638-25	Washer (slip ring to hub attachment)	10	X	X	X	X	X
135	A-1635-15	Screw (slip ring to hub attachment)	10	X	X	X	X	X
136	D-40553	Slip ring assembly	1	X	X	X	X	
136	D-40663	Slip ring assembly	1					X

McCAULEY PROPELLER SYSTEMS
OWNER/OPERATOR
INFORMATION MANUAL

Table 1013. C1100 Series Propeller Deice Equipment (continued)

INDEX NUMBER	PART NUMBER	DESCRIPTION	QTY	C	C	C	C	C
				1	1	1	1	1
				0	0	0	0	0
				1	2	3	4	5
145	A-1635-36	..Screw (bulkhead slip ring)	12	X	X	X	X	X
146	A-1638-20	..Washer (bulkhead slip ring)	12	X	X	X	X	X
152	C-40599	Brush block bracket assembly	1	X	X	X	X	
152	C-40684	Brush block bracket assembly	1					X
153	C-40567	..Bracket (brush block)	1	X	X	X	X	
153	C-40665	..Bracket (brush block)	1					X
154	A-1635-146	..Screw (terminal strip attachment)	2	X	X	X	X	X
155	A-40373	..Terminal strip	1	X	X	X	X	
155	A-40476	..Terminal strip	1					X
156	A-1639-43	..Nut (terminal strip attachment)	2	X	X	X	X	X
157	A-1638-17	..Washer (terminal strip attachment)	2					X
157	A-1638-17	..Washer (terminal strip attachment)	3	X	X	X	X	
158	A-1639-18	..Nut (inner terminal attachment)	2					X
158	A-1639-18	..Nut (inner terminal attachment)	3	X	X	X	X	
159	A-1639-19	..Nut (outer terminal attachment)	2					X
159	A-1639-19	..Nut (outer terminal attachment)	3	X	X	X	X	
160	A-1635-77	Screw (brush block to bracket)	2	X	X	X	X	
160	A-1635-100	Screw (brush block to bracket)	2					X
161	A-1638-7	Washer (brush block to bracket)	2	X	X	X	X	X
162	B-40024-8	Spacer (brush block to bracket)	2	X	X	X	X	X
163	A-1638-21	Shim (brush block to bracket)	AR	X	X	X	X	X
164	C-40631	Brush block assembly	1	X	X	X	X	
164	C-40685	Brush block assembly	1					X
165	A-40591	..Wire assembly	3	X	X	X	X	
166	A-1639-53	..Nut (brush attachment)	3	X	X	X	X	
167	A-1638-53	..Washer	6	X	X	X	X	
168	A-1639-18	..Nut (terminal attachment)	3	X	X	X	X	
169	A-1635-204	..Screw (brush attachment)	3	X	X	X	X	
170	C-40557	..Brush block	1	X	X	X	X	
170	C-40411	..Brush block	1					X
171	A-1635-127	..Screw (brush to brush assembly)	2					X
172	B-40571	..Brush assembly	6	X	X	X	X	
173	A-40478	..Spring	12	X	X	X	X	

McCAULEY PROPELLER SYSTEMS
OWNER/OPERATOR
 INFORMATION MANUAL

Table 1013. C1100 Series Propeller Deice Equipment (continued)

INDEX NUMBER	PART NUMBER	DESCRIPTION	QTY	C	C	C	C	C
				1	1	1	1	1
				0	0	0	0	0
				1	2	3	4	5
174	B-40464-1	..Brush assembly (right)	1					X
175	B-40464-2	..Brush assembly (left)	1					X
176	D-45081	Deice timer	1	X	X	X	X	X
177	C-45114	Deice timer	1					X
177	B-45018	Deice timer (optional)	1					X
178	C-40683	Bracket, transducer	1					X

McCAULEY PROPELLER SYSTEMS
OWNER/OPERATOR
INFORMATION MANUAL

C241

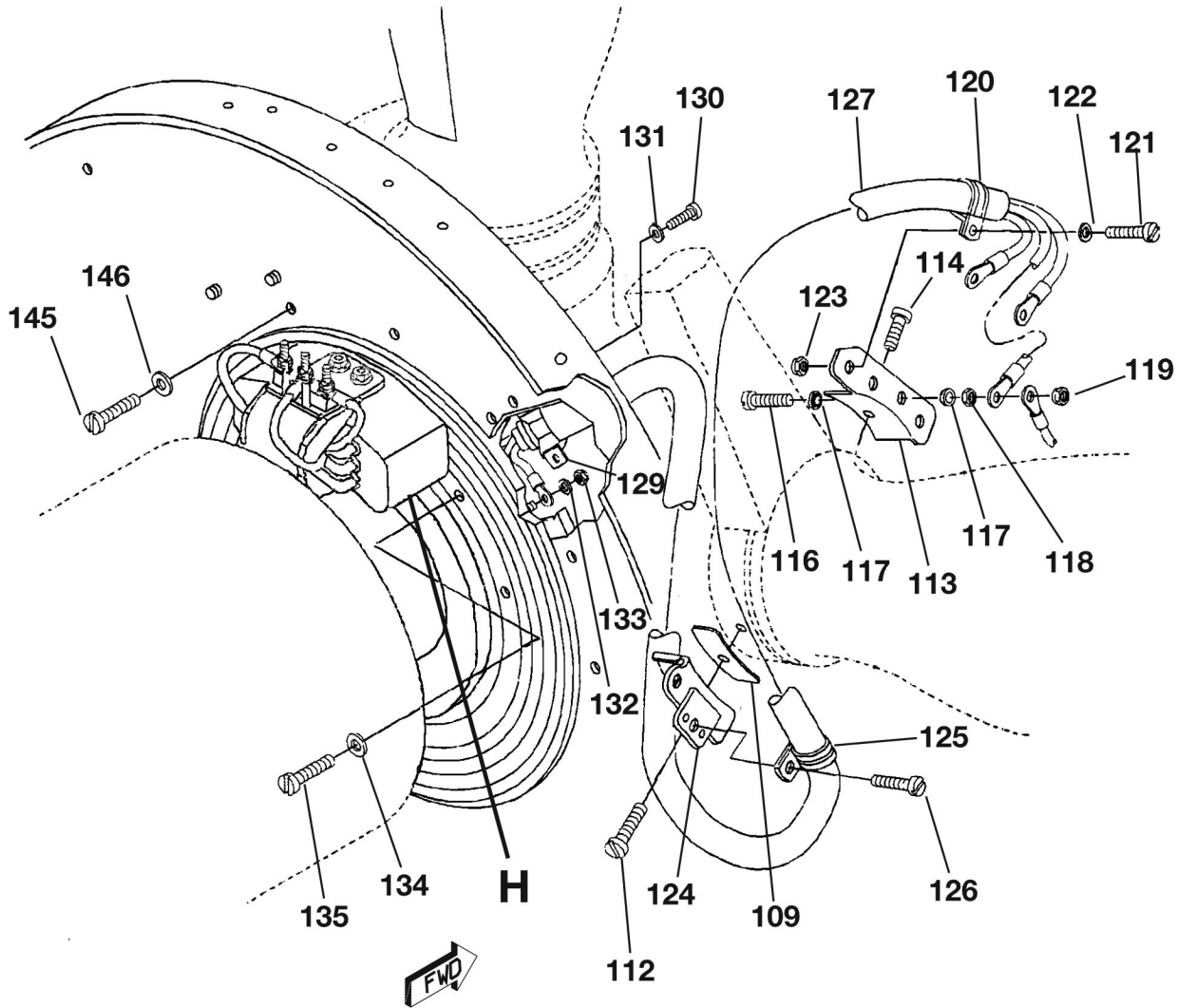

(C1101/C1103 PROPELLER SHOWN - C1102/C1104 ARE A MIRROR IMAGE)

McCauley Installed De-Ice System - C1100 Series
Figure 1007 (Sheet 1)

McCAULEY PROPELLER SYSTEMS
OWNER/OPERATOR
INFORMATION MANUAL

C238

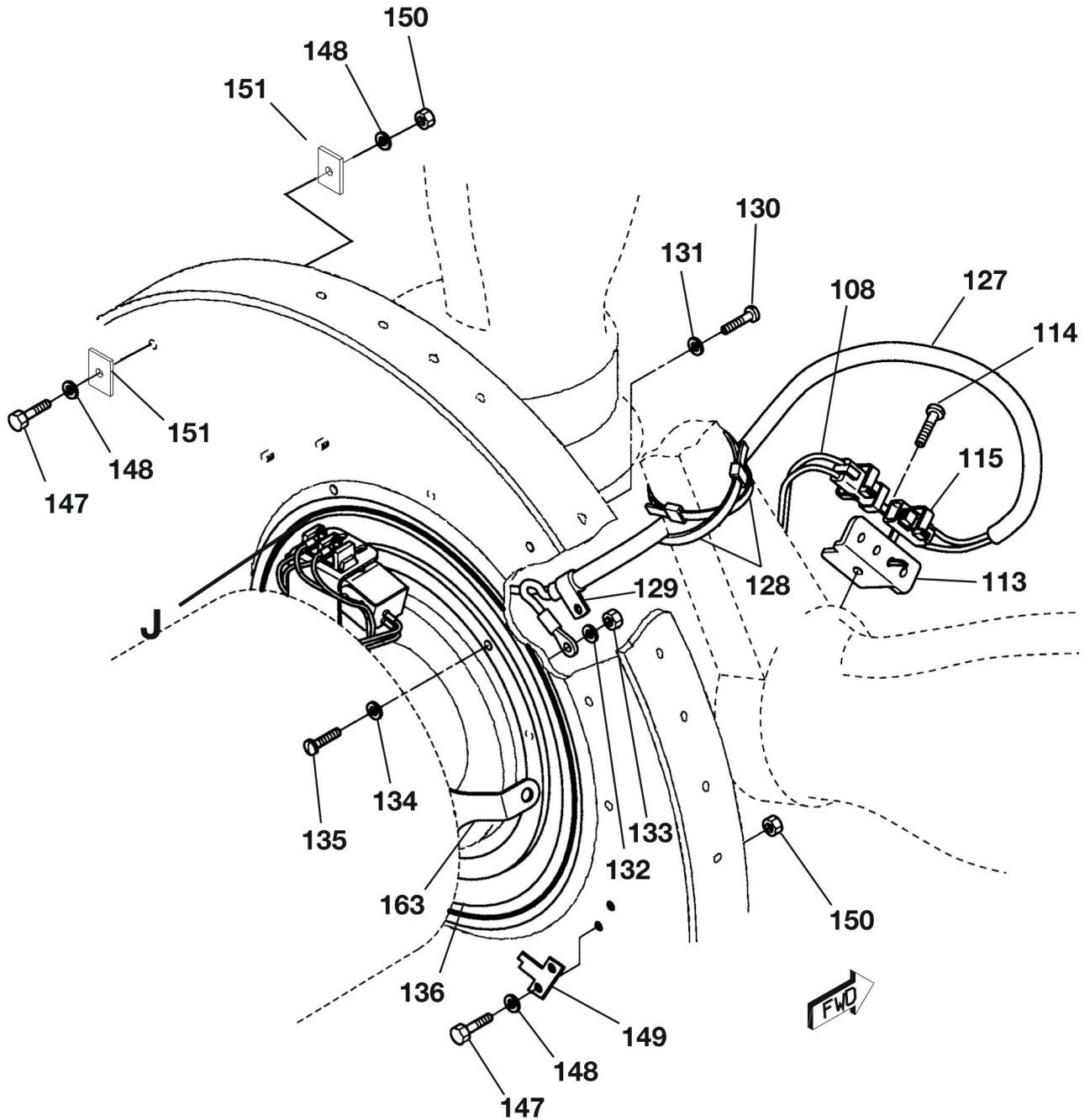

C1105 DEICE INSTALLATION

McCauley Installed De-Ice System - C1100 Series
Figure 1007 (Sheet 2)

McCAULEY PROPELLER SYSTEMS
OWNER/OPERATOR
 INFORMATION MANUAL

C240

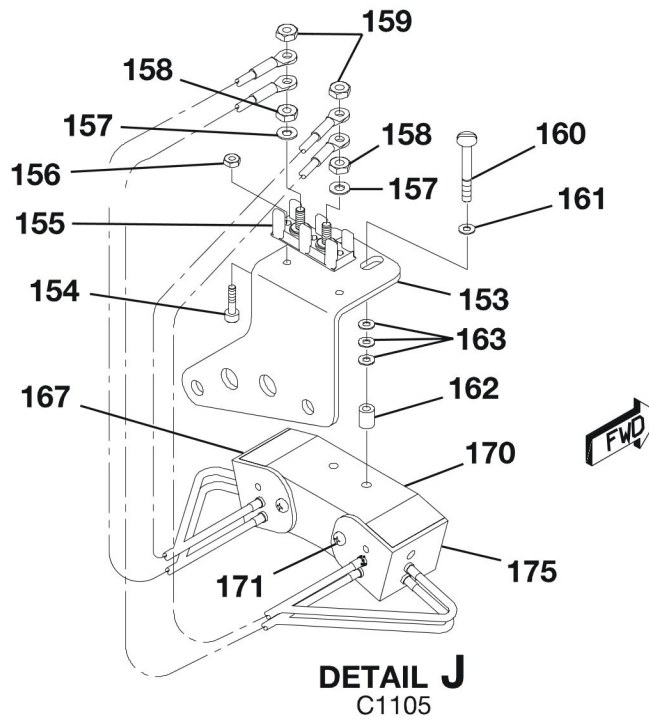
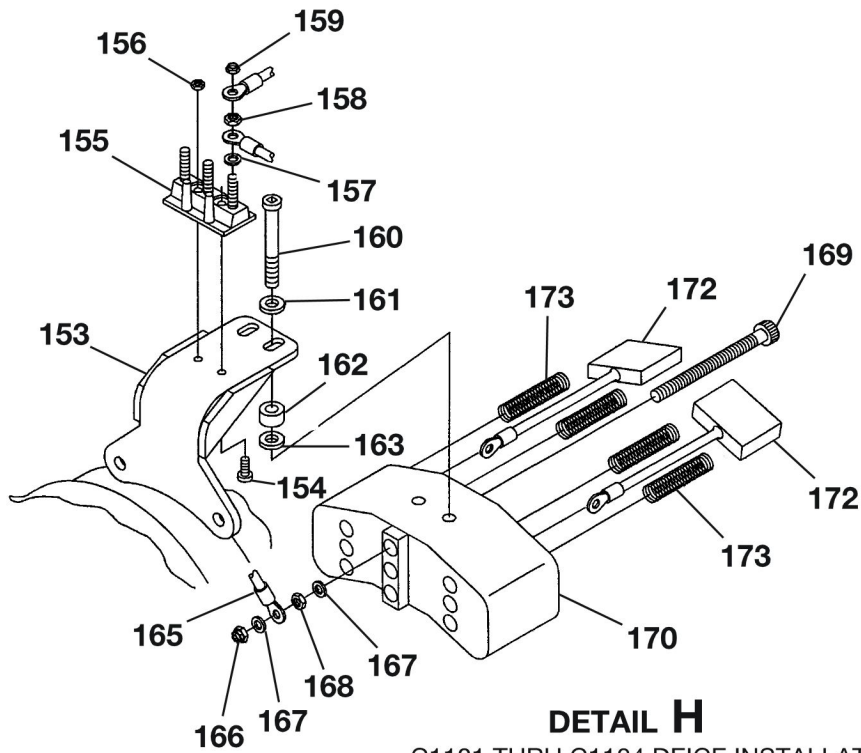

McCauley Installed De-Ice System - C1100 Series
 Figure 1007 (Sheet 3)

McCAULEY PROPELLER SYSTEMS
OWNER/OPERATOR
INFORMATION MANUAL

8. Deice Timers

- A. McCauley has developed solid state deice timers to replace the existing McCauley mechanical timers. The solid state timers are direct replacement parts for the mechanical timers. Replacement mechanical timers are no longer available. On aircraft installations that require the use of two deice timers, it is permissible to use one mechanical timer and one solid state timer.
- (1) Refer to the McCauley Propeller Systems Application Guide (MAG) and the aircraft type certificate data sheet for applications of specific part numbers.

NOTE: The MAG is **not** an FAA approved document, and is for reference only. Refer to the appropriate Type Certificate Data Sheet (TCDS) or Supplemental Type Certificate (STC) to verify information contained in the MAG.

Deice Timer Supercedure	
Mechanical Timers	Replacement Solid State Timers
B-45018	C-45114
B-45043	C-45116
B-45052	C-45133
B-45103	C-45118

McCAULEY PROPELLER SYSTEMS
OWNER/OPERATOR
INFORMATION MANUAL

ANTI-ICE SYSTEM DESCRIPTION AND OPERATION

1. Introduction

- A. This section provides installation, service, and parts information for propeller anti-ice systems and equipment manufactured by McCauley Propeller Systems.

NOTE: All data in this manual is applicable only to parts manufactured by McCauley. McCauley does not produce all of the components that are required for a working propeller fluid anti-ice system. The fluid holding tank, pump(s), fluid supply line to the propeller, and control components are not supplied by McCauley. Information concerning maintenance of components not supplied by McCauley and concerning operation of the anti-ice system should be obtained from the TC or STC holder. Section 61-10-45, Anti-ice System Parts Lists, provides information where component part numbers manufactured by McCauley can be found.

2. Applicable Regulations

- A. All maintenance and inspection procedures should be performed by qualified personnel. All work on anti-ice systems must comply with FAA Advisory Circular 43, Title 14 of the Code of Federal Regulations (CFR) Part 23, and superseding FAA releases. Where hardware or components have provisions for safety wiring, make sure that safety wire is installed in accordance with NASM33540, General Practices For Safety Wiring, Safety Cabling, Cotter Pinning.

3. Installation Description

- A. The propeller anti-ice system components provided by McCauley consists of the following:
- Anti-Ice Feed Shoes
 - Slinger Ring
 - Anti-Ice Supply Line
 - Spray Head Assembly

4. Principles Of Operation

- A. The anti-ice system is intended to prevent ice formation on the propeller blades of the airplane while operating in icing conditions. The Propeller Anti-Ice system includes propeller blade feed shoes, slinger ring, slinger nozzle, and supply tube and hose. The pilot controls the system by electrical switches that control the metering pumps that supply fluid to the propeller slinger ring.

5. Description of Deice System Components

- A. Anti-Ice Feed Shoes.
- (1) The anti-ice feed shoes are made of rubber and are attached to the inboard portion of each propeller blade. The shoes have grooves molded into them to provide a means of channeling or directing the anti-ice fluid over the surface of the propeller blade when the propeller is turning. Without the anti-ice shoes, the anti-ice fluid would not be evenly distributed over the propeller blades. One side of the shoe has a matte finish with grooves while the other side has a fabric impression finish to ensure a good bond between the shoe and the propeller blade.
- B. Slinger Ring.
- (1) The slinger ring is attached to the aft side of the propeller and catches the anti-ice fluid from the stationary propeller nozzle mounted on the engine and, using centrifugal force, directs the fluid to the rubber tubes that supply fluid to the propeller blade spray head assembly.
- C. Anti-Ice Supply Line.
- (1) The supply lines take fluid from the slinger ring and directs it to the propeller blade spray head assembly.
- D. Spray Head Assembly.
- (1) The propeller blade spray head assembly directs anti-ice fluid to the propeller blade feed shoes.

McCAULEY PROPELLER SYSTEMS
OWNER/OPERATOR
 INFORMATION MANUAL

6. Materials Required

A. Materials required for Anti-Ice Components Installation.

Table 201. Material Required for Anti-Ice Shoe Installation

Name	Part Number	Manufacturer	Quantity
Rubber Adhesive	1300L	3M Company 3M Ctr Bldg. 220-7W-03 Saint Paul, MN 55144-1000, Web: www.3m.com	As required
Sunbrite-Sterling Enamel Sealant	78-U-1003 with Catalyst U-1001-C	Sterling Lacquer Mfg. Co. 3150 Brannon Ave. St. Louis, MO 63139	As required
Fine Line Tape	218, 3/8 inch wide	3M Company	As required
Fine Line Tape	218, 1/2 inch wide	3M Company	As required
Fine Line Tape	218, 1 inch wide	3M Company	As required
Acid Brush	1/2 inch wide	Commercially available	As required
Paint Brush	3/4 inch wide	Commercially available	As required
	Bostik 1096M Adhesive	Bostik Findley, Inc. 211 Boston Street Middleton, MA 01949-2128 Phone: 978-777-0100, Web: www.bostik.com	NOTE: Bostik 1096M, is an approved alternate adhesive for 1300L (McCauley P/N A-1664-15).
	Bostik 1007M Primer	Bostik Findley, Inc.	Primer for Bostik 1096M Adhesive
	Bostik #9R	Bostik Findley, Inc.	Curative agent for Bostik 1096M Adhesive
	Bostik 2402 Adhesive (Part A)	Bostik Findley, Inc.	NOTE: Bostik 2402 Adhesive, is an approved alternate adhesive for 1300L (McCauley P/N A-1664-15).
	Bostik 9101 Adhesive (Part B)	Bostik Findley, Inc.	Part B shall be used with the Bostik 2402 Adhesive (Part A)
	Bostik 9252 Primer	Bostik Findley, Inc.	To prime metal parts prior to the application of the Bostik 2402 Adhesive.
Methyl n-Propyl Ketone (MPK)		Commercially available	

McCAULEY PROPELLER SYSTEMS
OWNER/OPERATOR
 INFORMATION MANUAL

Table 201. Material Required for Anti-Ice Shoe Installation (continued)

Name	Part Number	Manufacturer	Quantity
Toluol		Commercially available	Tackifying Solvent MPK may be used instead of Toluol to tackify cement. Toluol provides approximately 40 seconds of working time.
Cleaning cloth		Commercially available	Clean, lint-free cloth
2 inch rubber or wooden hand roller		Commercially available	To install deice boot
Lockwire	A-1640-5	McCauley	To secure fasteners
Blue Sentry Seal	A-1664-27	McCauley	To detect movement of fasteners

7. Propeller Anti-Ice Feed Shoes Removal/Installation

A. Remove the Propeller Anti-ice Feed Shoes (Refer to Figure 201).

WARNING: Cement and solvent vapors are toxic and extremely flammable. Use these chemicals only in a well ventilated area away from sparks and vapors. Excess exposure could cause injury or death. If dizziness or nausea occur, get to fresh air immediately. Avoid contact with skin or eyes. Use solvent-resistant gloves to minimize skin exposure. Use safety glasses to protect your eyes from chemicals. If you get chemicals in your eyes, flush your eyes with water for 15 minutes and see a physician immediately. If you get chemicals on your skin, wash thoroughly with soap and water. If you swallow chemicals, do not induce vomiting. See a physician immediately.

CAUTION: The jaws of any tool (vise grips, pliers, etc.) that you use to pull on the feed shoe must be cushioned to prevent damage to the feed shoe, unless the feed shoe is to be scrapped.

- (1) Make sure all electrical power switches are in OFF position.
- (2) Remove the spinner screws and fiber washers from the spinner, and remove the spinner from the spinner bulkhead.
- (3) If the feed shoe is to be discarded, remove it from the propeller blade without solvent.

NOTE: The feed shoe can tear or come off in pieces.

McCAULEY PROPELLER SYSTEMS
OWNER/OPERATOR
 INFORMATION MANUAL

CAUTION: When you remove feed shoes from a propeller assembly, be careful not to let solvent leak into the propeller hub and cause damage to the seals. The blade that is being worked on must be pointed down so all excess solvent will run to the outboard tip of the blade. As an extra precautionary measure, the hub and blade area must be masked. Do not use any sharp objects which might scratch the blade when you remove the feed shoe.

- (4) Use methyl n-propyl ketone or toluene to soften the adhesion line between the anti-ice feed shoe and the propeller blade. Start at one corner and loosen enough of the feed shoe to grasp it with vise grips, pliers, or similar tools.
- (5) Apply a steady pull to remove the feed shoe; pull the feed shoe from the blade slowly and carefully while you continue to use methyl n-propyl ketone or toluene to soften the adhesion line.
- (6) Remove all residual cement from the blade. Use solvents with caution as mentioned above.
- (7) Visually do an inspection of the propeller blade for damage or deterioration. Look for corrosion, cracks, dents or nicks. If defects are found, the propeller must be repaired by an authorized propeller repair station.

B. Install the Anti-ice Propeller Feed Shoes (Refer to Figure 201).

- (1) General.
 - (a) All anti-ice shoes on a single propeller must be located the same distance from the center line of the propeller for rotational balance. The ("W") dimension for the location of the anti-ice shoe is given in Table 202 and shown in Figure 201.

Table 202. Aircraft and System Identification and Information

Aircraft Make and Model No.	Shoe Part Number	Dim "W" See Note 2	McCauley Propeller Model No.	Notes See Note 1
Cessna 208, 208A, 208B	C-40323-83	0.600 to 0.850 Inch (15.24 to 21.59 mm)	3GFR34C703	3 blade propeller
Cessna 208B equipped with PT6A-140 Engine	C-40323-83	0.600 to 0.850 Inch (15.24 to 21.59 mm)	4HFR34C778	4 blade propeller
NOTE 1: Many McCauley propellers are provided to the aircraft manufacturer without the anti-ice shoes installed. In cases where the aircraft manufacturer installs the anti-ice shoes, or where non-McCauley anti-ice shoes are used, the appropriate aircraft manufacturer's service manual must be consulted for all installation information.				
NOTE 2: Anti-Ice Shoe Location Dimension "W" (Inches) See Figure 201.				

- (2) Prepare the Propeller Blades for the Feed Shoe Installation.
 - (a) Trim each propeller blade feed shoe if necessary.
 - (b) Mark the inboard center line on the leading edge of the propeller blades.
 - (c) Use a template or hand fit the anti-ice feed shoe to the blades so that the feed shoe center line is on the leading edge center line of the propeller blade.
 - (d) Mark an area 0.5 inch (12.70 mm) outside the feed shoe perimeter on the propeller blade with a red pencil.
 - (e) Use the red pencil line as the perimeter of the area on each propeller blade to be masked.
 - (f) Install masking tape around the outline.

McCAULEY PROPELLER SYSTEMS
OWNER/OPERATOR
 INFORMATION MANUAL

C2531

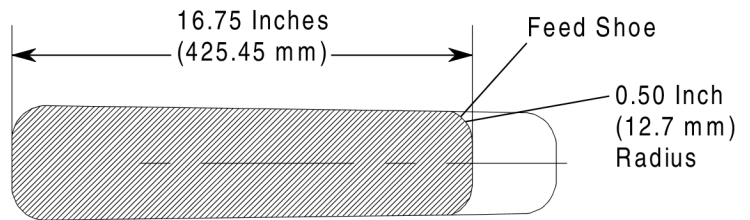
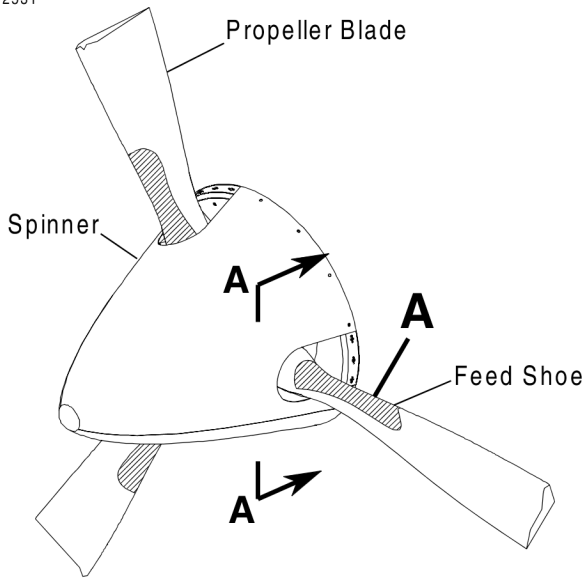

DETAIL A
 Feed Shoe Trim

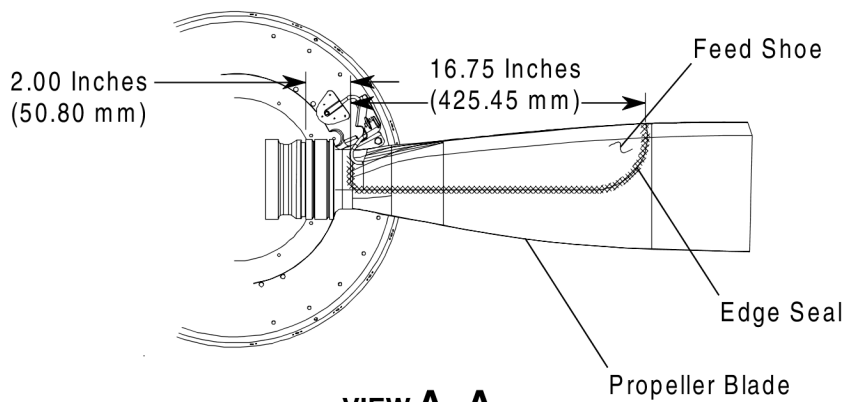

VIEW A-A
 Shown with Spinner Removed

2650T1011
 A2650T1011
 B2650T1011

C703 Propeller Anti-ice Feed Shoes (C778 similar)
 Figure 201 (Sheet 1)

McCAULEY PROPELLER SYSTEMS
OWNER/OPERATOR
INFORMATION MANUAL

C2432

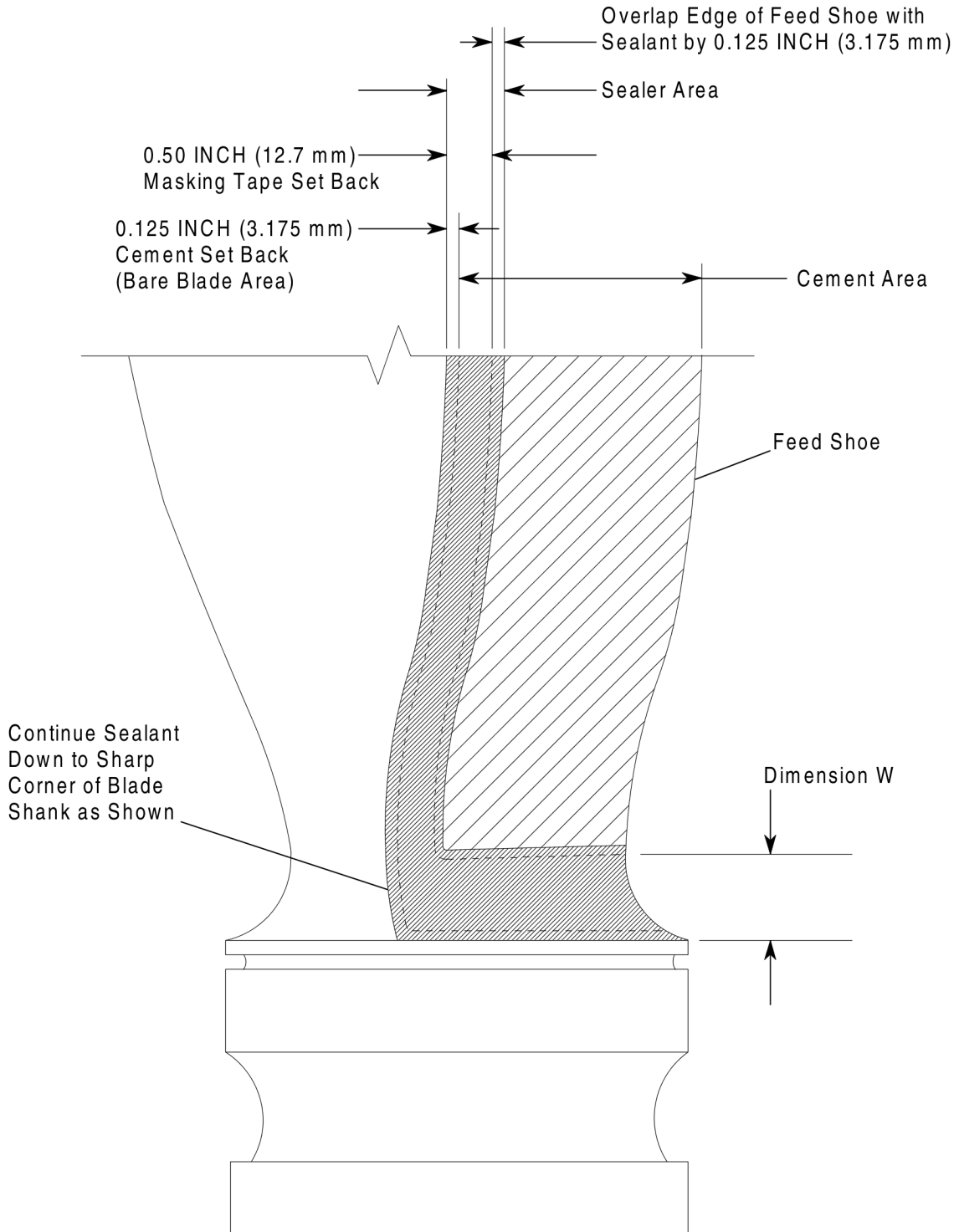

2614T1082

C703 Propeller Anti-ice Feed Shoes (C778 similar)
Figure 201 (Sheet 2)

McCAULEY PROPELLER SYSTEMS
OWNER/OPERATOR
INFORMATION MANUAL

CAUTION: It is necessary that the masking steps described be followed so the sealer will be applied to both the cement and 0.125 inch (3.18 mm) of bare metal. If the cement line and sealer line start at the same point, water will seep under the cement line and cause an unserviceable seal.

- (g) Remove all paint inside of the masked off area on propeller blades painted with lacquer. On propeller blades painted with polyurethane, lightly sand inside the masked off area with 400 grit sandpaper.
- (h) Clean all of the masked area on the propeller blades thoroughly with methyl n-propyl ketone or acetone. Quickly clean the solvent from the propeller blades with a clean, dry, lint-free cloth so that you do not leave a film.
- (i) Apply a second layer of masking tape on the propeller blades to cover an additional 0.125 inch (3.18 mm) of bare metal area inside of the previously masked area.

CAUTION: The metal and rubber parts must be clean. Only very clean surfaces will cause maximum bond of the cement.

- (3) Apply Cement to the Feed Shoes and the Propeller Blades.
 - (a) Lightly sand the bond surface of the feed shoe with sandpaper to cause maximum bond.
 - (b) Moisten a clean cloth with methyl n-propyl ketone or acetone. Clean the bond surface of the anti-ice feed shoe. Change the cloth frequently to avoid contamination of the clean area.

NOTE: You can use masking tape to prevent any curl of the anti-ice feed shoe edges when you apply cement to the back side of the feed shoe.

- (c) Apply masking tape to the breeze side of the feed shoe edges. Let approximately 0.250 inch (6.35 mm) of the tape overhang the edge of the feed shoe.
- (d) Lay the feed shoe on a piece of cardboard with the bond side up. Tape the feed shoe onto the cardboard with the 0.250 inch (6.35 mm) overlap of masking tape.
- (e) Make sure to thoroughly mix the cement.
- (f) Apply one even brush coat of 1300L or EC1403 cement to the clean, masked surface of the propeller blade and to the fabric impression side of the anti-ice feed shoe. Apply cement at the room temperature of 60 to 75° F (15.56 to 23.89° C).
- (g) Allow the cement to air dry for a minimum of one hour at 40° F (4.44° C) or above, when the relative humidity is less than 75%. If the humidity is 75% to 90%, additional drying time will be necessary to cure the cement. Do not apply cement if the relative humidity is higher than 90%.
- (h) After the cement is dry (not tacky), apply a second even brush coat to the anti-ice feed shoe. Then immediately apply an even brush coat of cement to the clean masked off area of the propeller. Timing is important because the cement on both surfaces must reach the tacky stage at the same time.
- (4) Install Feed Shoes to the Propeller Blades.
 - (a) Remove the anti-ice feed shoe from the cardboard, and the masking tape from the anti-ice feed shoe before you start the installation.
 - (b) When the cement is tacky on both the propeller blade and feed shoe surfaces, put the anti-ice feed shoe center line to the center line on leading edge of the blade. Start with the inboard end of the blade and work toward the tip.
 - 1 If the cement dries, use methyl n-propyl ketone or toluene as necessary until the cement is tacky.
 - 2 If the feed shoe is off center, pull it up with a quick motion and install it again.
 - 3 Use methyl n-propyl ketone or toluene as necessary when you have to install the feed shoe again.
 - (c) When the feed shoe is correctly in place, use a rubber or wooden hand roller and press firmly on the full length of the leading edge to form a tight bond.

McCAULEY PROPELLER SYSTEMS
OWNER/OPERATOR
INFORMATION MANUAL

- (d) Gradually push the roller over each side of the leading edge contour to avoid trapping air. Roll from the leading edge of the propeller blade toward the tip. Work all excess feed shoe material out to the perimeter before you move to the next section. If there is excess material at the feed shoe edges that tends to pucker, use your fingers and carefully work puckers smooth.
- (e) Remove the masking tape from the propeller blades.
- (5) Apply Sealer to the Feed Shoes and Propeller Blades.
 - (a) Mix two parts of Sunbrite 78U1003 brushable black enamel with one part of enamel catalyst U-1001-C.

CAUTION: It is necessary that the masking steps described be followed so the sealer will be applied to both the cement and 0.125 inch (3.18 mm) of bare metal. If the cement line and sealer line start at the same point, water will seep under the cement line and cause an unserviceable seal (Refer to Figure 201).

- (b) Apply one, even, brush coat of sealer to the area around the feed shoe and make sure you cover the 0.125 inch (3.18 mm) of bare metal and adhesive along with the masked off area of 1/8 inch of the anti-ice feed shoe. Remove the masking tape as the sealer is brushed on, otherwise, the sealer will pull up along with the tape. Let the sealer dry.

8. Slinger Ring and Feed Nozzle Alignment Check

- A. C703 and C778 Model Propeller Nozzle Alignment Check (Refer to Figure 202 and Figure 203).
 - (1) Examine the Propeller Feed Nozzle to Slinger Ring Alignment.
 - (2) Measure the distance between the propeller feed nozzle and the slinger ring channel.

NOTE: The propeller feed nozzle must extend into the slinger ring channel 0.1 to 0.15 inches (2.54 to 3.81 mm) and have an edge distance of 0.1 to 0.15 inches (2.54 to 3.81 mm) from the slinger ring.

- (3) Adjust the propeller feed nozzle to direct the fluid stream to land in the slinger ring channel as necessary.
 - (a) Bend and rotate the feed nozzle at the fitting to align the nozzle with the slinger ring channel.
 - (b) Extend the feed nozzle into the slinger ring channel 0.1 to 0.15 inches (2.54 to 3.81 mm) with an edge distance of 0.1 to 0.15 inches (2.54 to 3.81 mm) from the slinger ring.
- (4) Rotate the propeller slowly by hand and make sure the distance between the slinger ring and the feeder tube is in alignment tolerance. Adjust the feed nozzle as necessary to get the required alignment.

9. C778 Model Propeller Spray Head Removal and Installation

- A. Spray Head Assembly Removal (Refer to Figure 203 and Figure 1001).
 - (1) Remove the propeller spinner, refer to the Propeller Removal/Installation section of this manual for instructions to remove the propeller spinner.
 - (2) Loosen the clamp (212) attaching the hose (211) to the spray head assembly (210).
 - (3) Remove the hose (211) from the spray head assembly (210).
 - (4) Remove screws (215) securing the spray head assembly to the propeller blade.
 - (a) If screws (215) are secured with lockwire, remove the lockwire and discard.
 - (b) If either screw (215) is securing balance weights to the propeller blade, note the number and location of the balance weights and the screw securing the balance weights and spray head assembly to the propeller blade.

NOTE: The screw length securing the balance weights is dependant on the number of balance weights used. Use the same length screw for reinstallation of balance weights and the spray head assembly.

- (5) Remove the spray head assembly (210).

McCAULEY PROPELLER SYSTEMS
OWNER/OPERATOR
 INFORMATION MANUAL

C2532

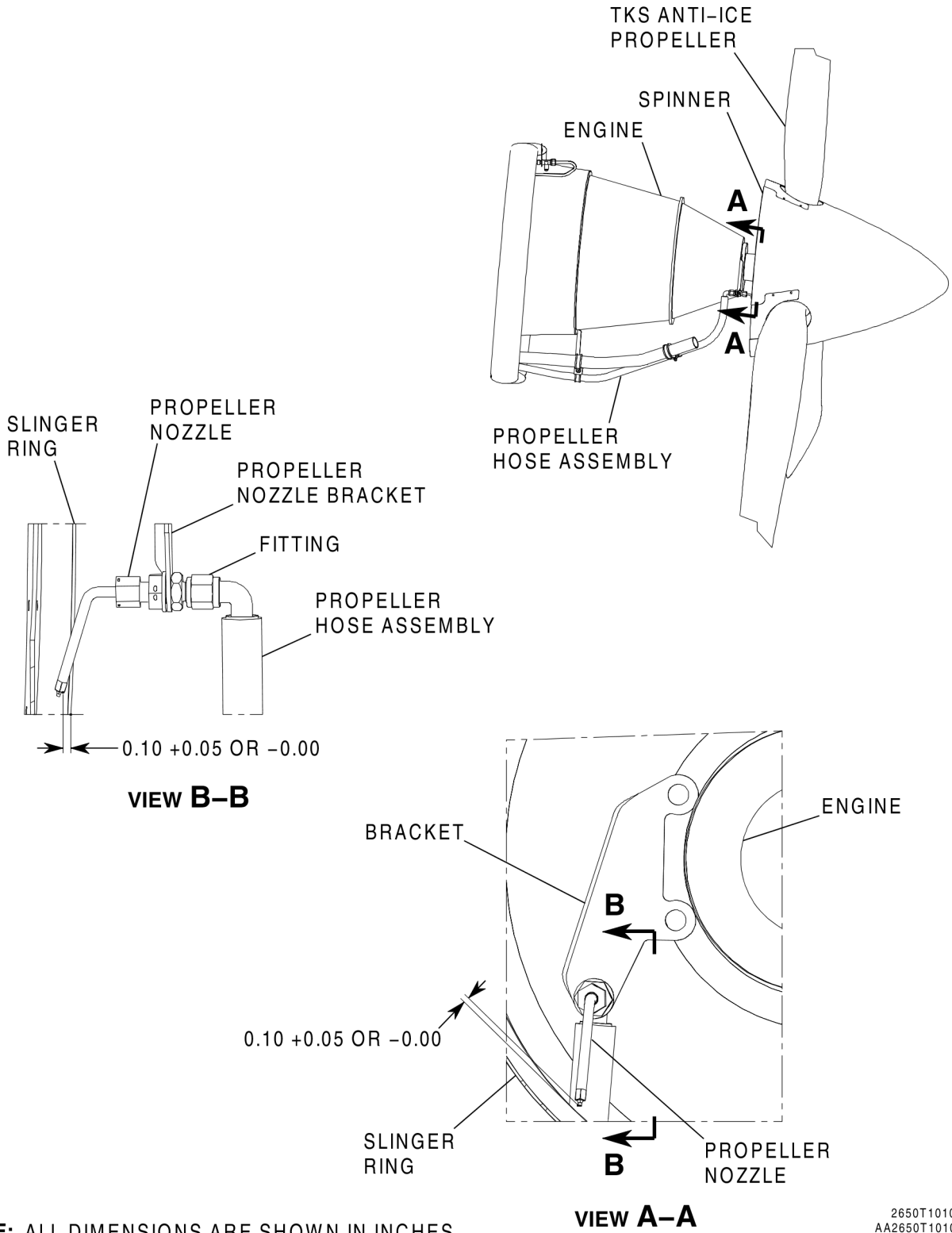

NOTE: ALL DIMENSIONS ARE SHOWN IN INCHES.

2650T1010
 AA2650T1010
 BB2650T1010

C703 Slinger Ring and Feed Nozzle Alignment Check
 Figure 202 (Sheet 1)

McCAULEY PROPELLER SYSTEMS
OWNER/OPERATOR
 INFORMATION MANUAL

C2451

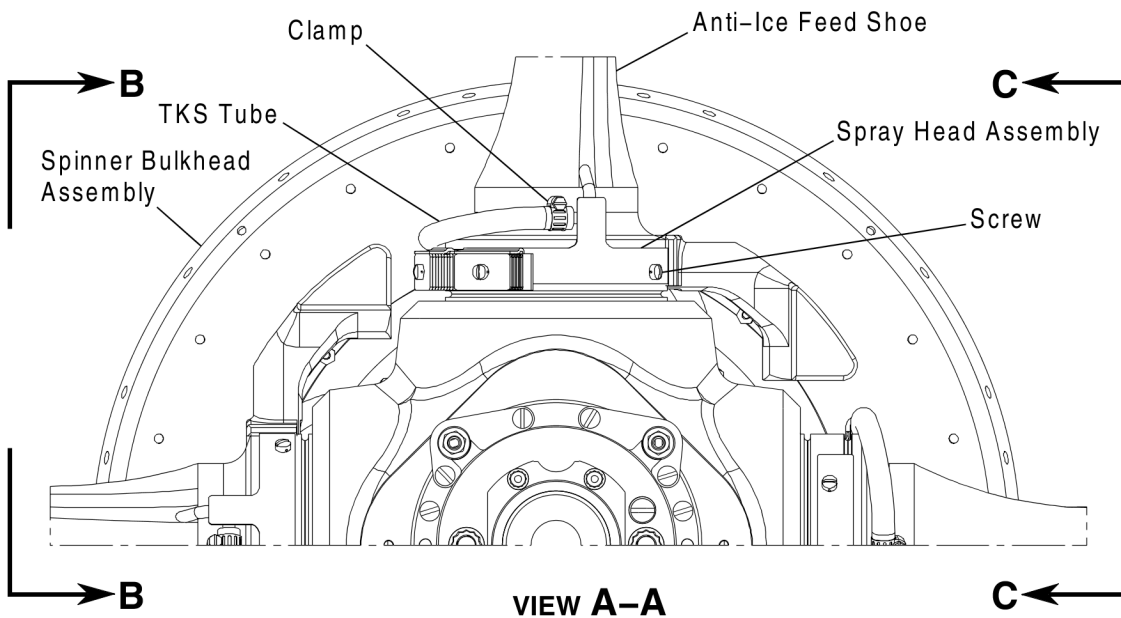
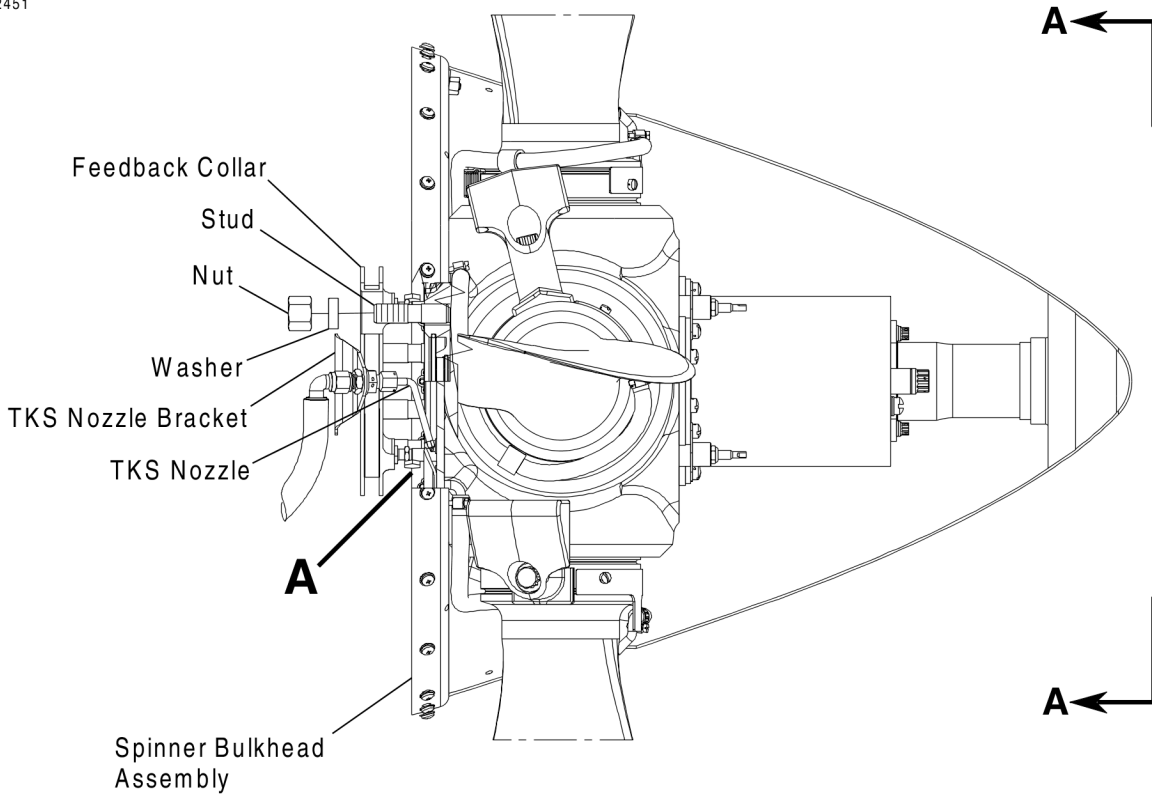

D-60366
 D-8096

C778 Anti-Ice Installation and Propeller Nozzle Alignment Check
 Figure 203 (Sheet 1)

McCAULEY PROPELLER SYSTEMS
OWNER/OPERATOR
 INFORMATION MANUAL

C2452

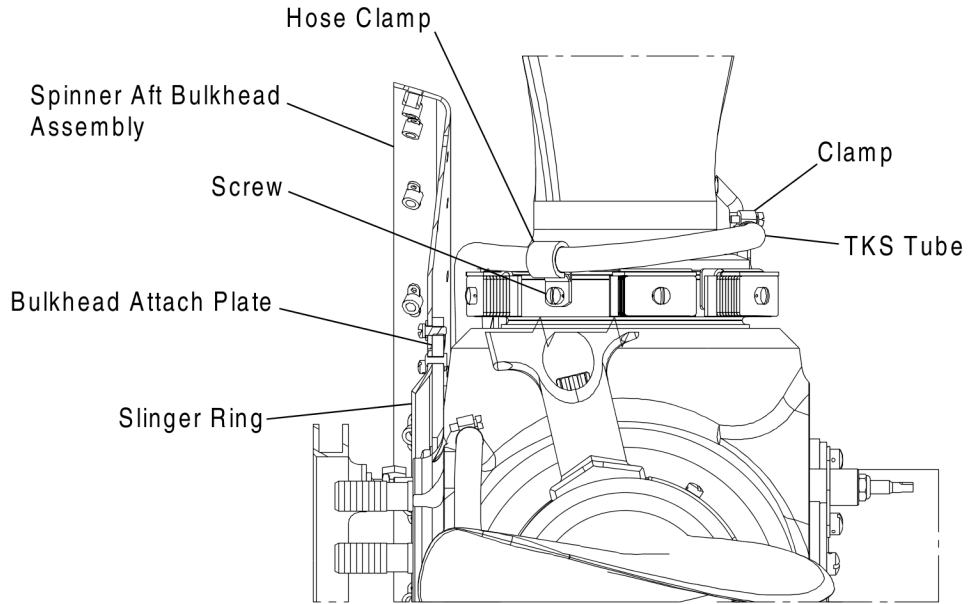

VIEW B-B

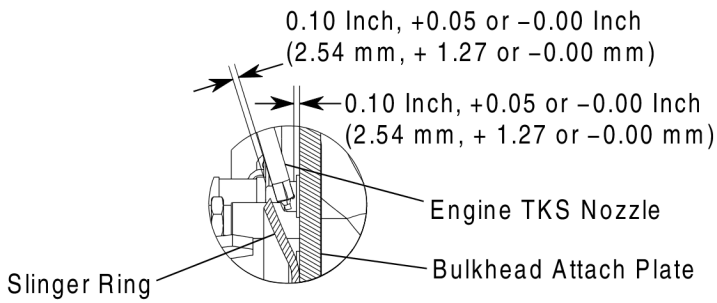

DETAIL A

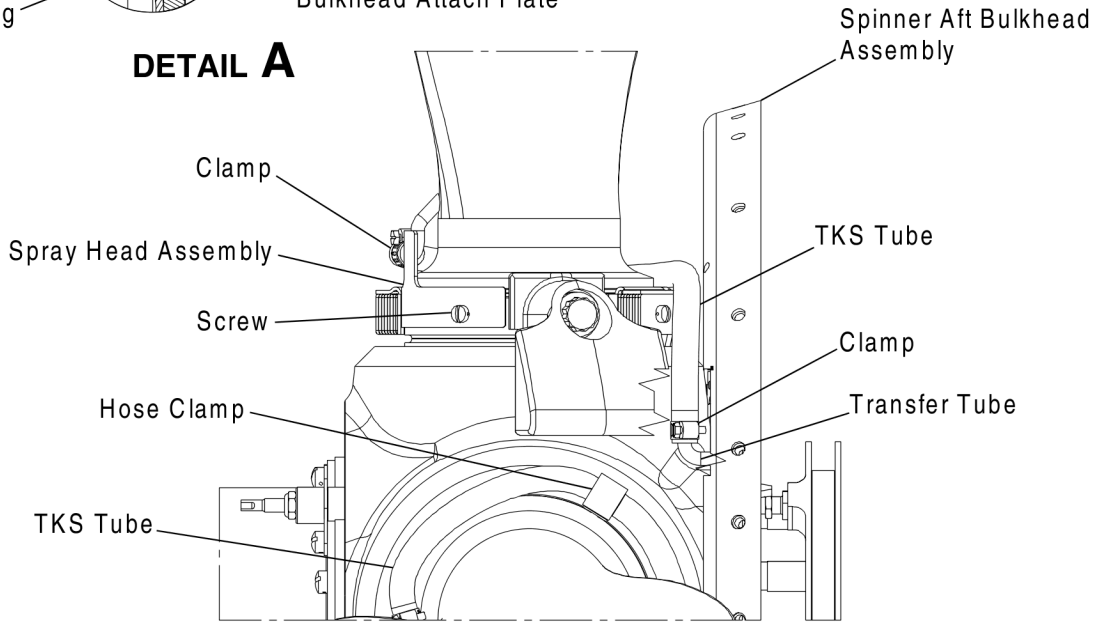

VIEW C-C

D-60366
 D-8096

C778 Anti-Ice Installation and Propeller Nozzle Alignment Check
 Figure 203 (Sheet 2)

McCAULEY PROPELLER SYSTEMS
OWNER/OPERATOR
INFORMATION MANUAL

B. Spray Head Assembly Installation.

- (1) Position the sprayhead assembly (210) on the propeller blade. Make sure the nozzle of the spray head assembly is positioned near the leading edge of the propeller blade.
- (2) Using retained screws (215) and balance weights, if applicable, secure the sprayhead assembly to the propeller blade.
 - (a) Make sure the same number and location of balance weights and screws are used to install the spray head assembly as were used during the removal of the sprayhead assembly.
 - (b) For screws that will not be secured with safety wire, apply A-1664-1 sealant to the threads of the screws.
 - (c) Torque screws (215) 30 to 36 Inch Pounds (3.39 to 4.07 N-m).
 - (d) Make sure the centerline of each propeller blade sprayhead tube is aligned with the groove in the anti-ice shoe.

NOTE: The position of the sprayhead tube should be aligned as close as possible with the center groove of the feed shoe.

- (e) Make sure there is a clearance of 0.032 to 0.100 inch (0.81 to 2.54 mm) between the sprayhead tube and the anti-ice shoe.
- (f) Secure the screws.
 - 1 If safety wire was used to secure the attach screws (215), use A-1640-5 lockwire to secure them.
 - 2 If safety wire was not used, apply A-1664-27 Blue Sentry Seal to the screws heads and the balance weight or spray head assembly so any movement of the fastener can be detected.
- (g) Attach hose (211) to spray head assembly (210).
- (3) Secure hose with clamp (212).
 - (a) Make sure the clamp (212) is positioned in a manner that will not interfere with the propeller blade or spinner.
- (4) Install the propeller spinner, refer to the Propeller Removal/Installation section of this manual for instructions to install the propeller spinner.

10. C778 Propeller Anti-Ice Fluid Tubes Removal and Installation

A. Tube Removal (Refer to Figure 203 and Figure 1001).

- (1) Remove the propeller spinner, refer to the Propeller Removal/Installation section of this manual for instructions to remove the propeller spinner.
- (2) Loosen the clamps (212) attaching the hose (211) to the spray head assembly (210) and the slinger ring assembly (150).
- (3) Remove the screw (216) and clamp (214) from the hose (211).
- (4) Remove the hose (211).

B. Tube Installation

- (1) Position the hose (211) on the spray head assembly (210) and the slinger ring assembly (150).
 - (a) Make sure the hose is not twisted or kinked as it is routed around the propeller blade and that there is sufficient length to the hose to allow for the full range of propeller blade travel without damaging the hose or the propeller assembly.
- (2) Secure hose with clamps (212).
 - (a) Make sure the clamps (212) are positioned in a manner that will not interfere with the propeller blade, spinner, or slinger ring assembly (150).
 - (b) After clamps (212) have been tightened and the hose is secure, cut off and remove excess strap material from the clamps.
- (3) Install the screw (216) and clamp (214) and secure the hose (211) to the propeller blade.
 - (a) Torque screws (214) 30 to 36 Inch Pounds (3.39 to 4.07 N-m).
 - 1 Mark the screw (216) to the clamp (214) using A-1664-27 Blue Sentry Seal so any movement of the fastener can be detected.
- (4) Do a final check of hose routing to make sure the hose is not twisted or kinked as it is routed around the propeller blade and that there is sufficient length to the hose to allow for the full range of propeller blade travel without damaging the hose or the propeller assembly.

McCAULEY PROPELLER SYSTEMS
OWNER/OPERATOR
INFORMATION MANUAL

- (5) Install the propeller spinner, refer to the Propeller Removal/Installation section of this manual for instructions to install the propeller spinner.

11. Propeller Slinger Ring Assembly Removal and Installation

- A. The propeller slinger ring for C700, C750, and C1000 series propellers should be removed and installed only by an FAA approved or international equivalent propeller repair station by qualified personnel.

CAUTION: The removal and installation of the slinger ring assembly will have an effect on the adjustment of the propeller beta rods/feedback collar assembly. Altering the settings of the beta rods/feedback collar assembly can have an adverse effect on propeller performance and operation.

12. Spinner Bulkhead Assembly Removal and Installation

CAUTION: The slip ring/slinger ring is installed as part of the propeller assembly procedure. Any adjustment requires partial disassembly of the propeller.

CAUTION: Make sure that the number "1" stamped on the bulkhead assembly is lined up with the number 1 propeller blade.

- A. Spinner Bulkhead Assembly Removal (Refer to Figure 203 and Figure 1001).
 - (1) Remove the propeller from the engine, refer to the Propeller Removal/Installation section of this manual for instructions to remove the propeller.
 - (2) Remove lockwire from screws (106).
 - (3) Remove screws (106) and washers (107) that attach the bulkhead assembly (102) to the slinger ring assembly (150).
 - (4) Remove spinner bulkhead assembly.
- B. Spinner Bulkhead Assembly Installation (Refer to Figure 203 and Figure 1001).
 - (1) Line up the number "1" stamped on the spinner bulkhead assembly with the number 1 propeller blade.
 - (2) Attach the bulkhead assembly (102) to the slinger ring assembly (150) with the bulkhead/slip ring attachment washers (107) and screws (106).
 - (3) Torque the screws (106) 20 to 25 Inch Pounds (2.26 to 2.82 N-m).
 - (4) Safety wire the screws in groups of two with A-1640-1 lockwire.
 - (5) Install the propeller on the engine, refer to the Propeller Removal/Installation section of this manual for instructions to install the propeller.

13. Troubleshooting

- A. Refer to the airplane maintenance manual or STC holder maintenance instructions for troubleshooting information concerning anti-ice fluid supply to the propeller assembly.
- B. Troubleshooting guide for McCauley installed components, refer to Table 203.

McCAULEY PROPELLER SYSTEMS
OWNER/OPERATOR
 INFORMATION MANUAL

Table 203. Troubleshooting Guide

Trouble	Probable Cause	Corrective Action
1. No or insufficient fluid to the propeller blade feed shoe(s).	A. No or insufficient anti-ice fluid flow to the slinger ring.	Refer to the airplane maintenance manual or STC holder maintenance instructions for troubleshooting information concerning anti-ice fluid supply to the propeller slinger ring.
	B. Obstructions in the anti-ice fluid lines from the slinger ring assembly to the propeller blade spray head assembly.	Check for obstructions in the propeller fluid lines. Remove any observed obstructions.
	C. Engine side anti-ice fluid nozzle is not installed correctly to direct fluid to the slinger ring.	Do a Slinger Ring and Feed Nozzle Alignment check.
	D. Slinger Ring is damaged.	Replace Slinger Ring.
	E. Loose or disconnected propeller fluid lines or tubes.	Reconnect and secure propeller fluid lines or tubes.
	F. Damaged lines, tubes or nozzles.	Replace damaged components.

McCAULEY PROPELLER SYSTEMS
OWNER/OPERATOR
INFORMATION MANUAL

ANTI-ICE SYSTEM - INSPECTION/CHECK

1. General

- A. The propeller anti-ice components should be inspected on a scheduled basis for condition and security.

2. 100 Hour Inspection

- A. Remove spinner dome and open access doors as necessary. Do not run an engine with the spinner dome removed or damage to the spinner fillets will occur.

B. Anti-Ice Shoes.

- (1) Closely check each anti-ice shoe for wrinkled, loose, or torn areas, particularly around the outboard edges. Look for abrasion or cuts, especially along the leading edge and the face or flat side of the blade.

- (a) Foreign object damage must be given careful inspection, not just for damage to the shoe, but also for blade damage beneath the shoe. Shoe elasticity may obscure blade damage. If the shoe is damaged or cut completely through to the blade or if blade damage beneath a shoe is suspected, the shoe must be removed for blade inspection/repair.

C. Slinger Ring.

- (1) Visually check the slinger ring for condition and security. Replace any slinger ring assembly that is cracked, warped or has an out-of-round condition. Make sure the fluid path in the slinger ring assembly is clean and free of any debris.

D. Spray Head Assembly.

- (1) Visually check the sprayhead assembly for condition and security. Replace any spray head assembly that is cracked or has a noticeable dent. Make sure the tube is clear and free of any blockage.

(a) For C778 propeller installations:

- 1 Make sure the centerline of each propeller blade sprayhead tube is aligned with the groove in the anti-ice shoe.

NOTE: The position of the sprayhead tube should be aligned as close as possible with the center groove of the feed shoe.

- 2 Make sure there is a clearance of 0.032 to 0.100 inch (0.81 to 2.54 mm) between the anti-ice tube and the anti-ice shoe.

- 3 Check the security of screws that are safety wired or the condition of the Sentry Seal for screws that are not safety wired.

E. Fluid Tubes.

- (1) Visually check the fluid tubes for condition and security. Replace any tube that is cracked or is in a deteriorated condition.

McCAULEY PROPELLER SYSTEMS
OWNER/OPERATOR
 INFORMATION MANUAL

ANTI-ICE SYSTEM ILLUSTRATED PARTS LIST

1. Illustrated Anti-Ice Parts List C700 and C750 Series Propellers

- A. An exploded view of a typical McCauley propeller supplied deice equipment appears following the Master Anti-Ice Parts List (Tables 1001 and 1002). The index numbers for parts in the illustration are used to identify detail part numbers, assemblies, or groups of similar part numbers in the Parts List.
- (1) Figure 1001 illustrates McCauley installed anti-ice systems.
 - (2) Refer to the McCauley Propeller Systems Application Guide (MAG) and the aircraft type certificate data sheet or supplemental type certificate information for applications of specific part numbers.

NOTE: The MAG is **not** an FAA approved document, and is for reference only. Refer to the appropriate Type Certificate Data Sheet (TCDS) or Supplemental Type Certificate (STC) to verify information contained in the MAG.

Table 1001. McCauley Provided Anti-Ice Shoes

PART NUMBER	DESCRIPTION	QTY	C703	C778
C-40323-8 3	Shoe	3	X	
C-40323-8 3	Shoe	4		X

Table 1002. McCauley Provided Anti-Ice Equipment Installations

INDEX NO.	FIGURE 1001 SHEET NO.	PART NUMBER	DESCRIPTION	QTY	C703 Cessna 208/208B	C778 Cessna 208B
102	1	E-7844	Spinner Bulkhead	1	X	
106	1	A-1635-36	Screw	12	X	
107	1	A-1638-20	Washer	12	X	
213	1	C-40323-83	Shoe	3	X	
217	1	13125-07	Feed Tube - Propeller (Cessna Part)	3	X	
218	1	13125-03	Clamping Plate (Cessna Part)	3	X	
219	1	13125-05	Bracket - Propeller Nozzle (Cessna Part)	3	X	
220	1	A-2513-104	Bolt	9	X	
221	1	A-1638-7	Washer	9	X	
222	1	A-1639-40	Nut	9	X	
102	2	E-5327	Spinner Bulkhead	1		X
106	2	A-1635-36	Screw	12		X
107	2	A-1638-20	Washer	12		X

McCAULEY PROPELLER SYSTEMS
OWNER/OPERATOR
 INFORMATION MANUAL

Table 1002. McCauley Provided Anti-Ice Equipment Installations (continued)

INDEX NO.	FIGURE 1001 SHEET NO.	PART NUMBER	DESCRIPTION	QTY	C703 Cessna 208/208B	C778 Cessna 208B
150	2	D-40750	Slinger Ring Assembly	1		X
210	2	B-40755	Spray Head Assembly	4		X
211	2	A-2779-5	Tube	4		X
212	2	A-2873-8	Clamp	8		X
213	2	C-40323-83	Shoe	4		X
214	2	A-2873-13	Clamp	4		X
215	2	A-1635-4	Screw	AR		X
215	2	A-1635-5	Screw	AR		X
215	2	A-1635-14	Screw	AR		X
215	2	A-1635-120	Screw	AR		X
215	2	A-1635-15	Screw	AR		X
215	2	A-1635-121	Screw	AR		X
215	2	A-1635-96	Screw	AR		X
215	2	A-1635-116	Screw	AR		X
215	2	A-1635-121	Screw	AR		X
215	2	A-1635-54	Screw	AR		X
215	2	A-1635-118	Screw	AR		X
216	2	A-1635-5	Screw	4		X
223	2	13125-04	Propeller Nozzle (Cessna Part)	1		X
227	2	B-40763	Bracket - TKS Nozzle	1		X

McCAULEY PROPELLER SYSTEMS
OWNER/OPERATOR
INFORMATION MANUAL

C2491

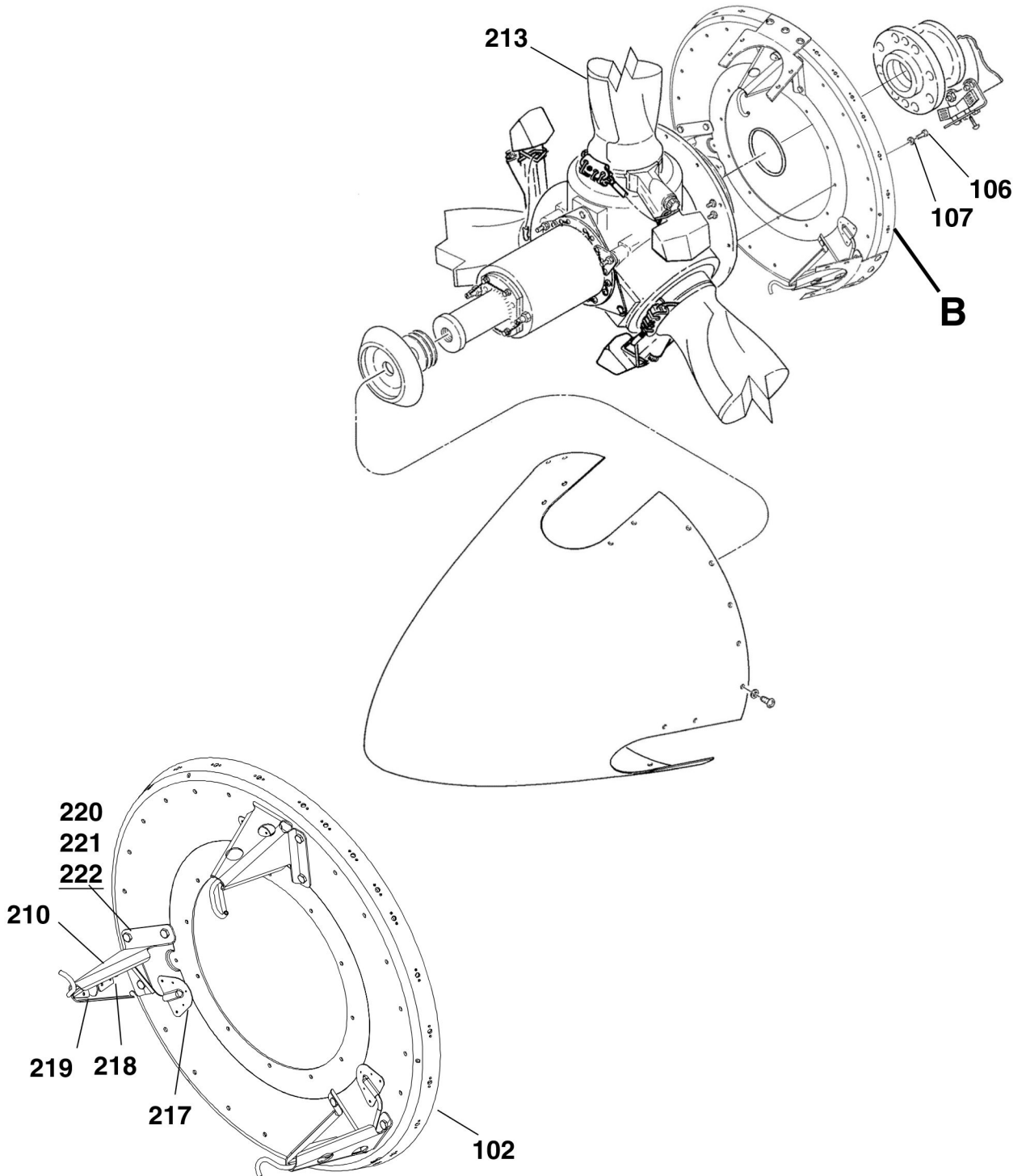

DETAIL B

McCauley Installed Anti-Ice System
Figure 1001 (Sheet 1)

2650R2001
B2650T1012

McCAULEY PROPELLER SYSTEMS
OWNER/OPERATOR
INFORMATION MANUAL

C2456

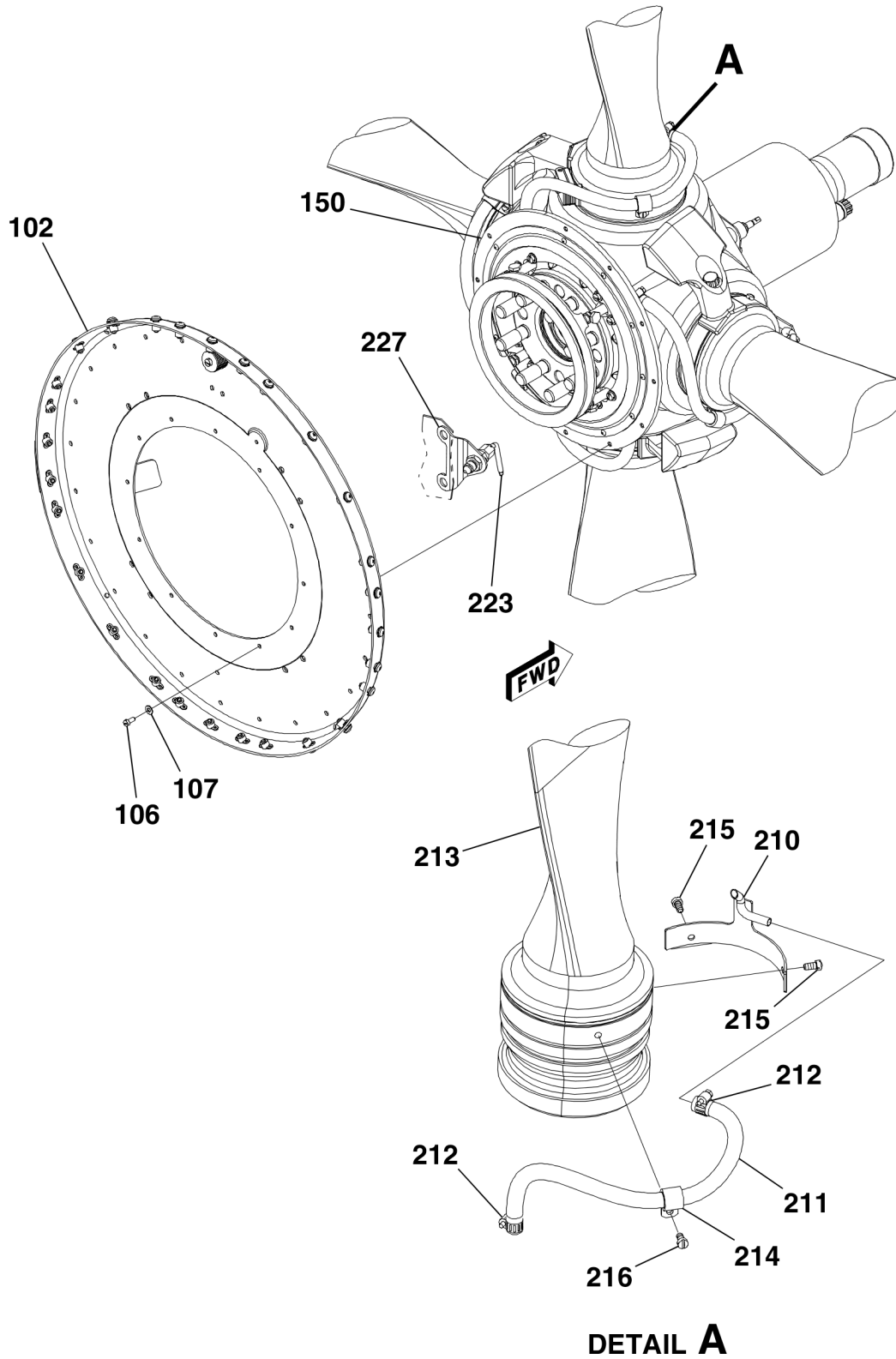

DETAIL A

McCauley Installed Anti-Ice System
Figure 1001 (Sheet 2)

D-8096